

FANBACK SERIES ASSEMBLY INSTRUCTIONS



(717) 354-8998 • (877) 560-5966
New Holland, PA

#365 Fanback Rocker



Tools Required

- Hammer
- #2 Square Head Bit
- Power Drill
- 7/16" Socket or 7/16" Wrench

Included Hardware

A		2	1/4" x 2 1/2" Carriage Bolt
B		6	1/4" x 3" Carriage Bolt
C		8	1/4" Nut
D		2	1/4" x 3 1/2" Lag Bolt
E		4	2" Screws

Instructions:

1. Unpack items from box(es). Be sure to match any numbers & letters that you may find on the pieces.
2. To begin, line up the back and pull the back tight to the seat slat. (Illustration 2)
3. With a #2 Square Head Bit, insert 2 (E) 2" screws into the pre-drilled holes and fasten to the bottom back board. (Illustration 2)
4. Fasten the arm & leg combo to the seat and seat back using 2 (B) 1/4" x 3" Carriage Bolt, 2 (C) 1/4" Nuts & 1 (D) 1/4" x 3 1/2" Lag Bolt. Do not tighten the nuts till complete. (Illustration 3)
5. Repeat step 4 for the other side.
6. Turn the chair upside down with the arms down. Fasten the rocker runners with 1 (A) 1/4" x 2 1/2" Carriage Bolt, 1 (B) 1/4" x 3" Carriage Bolt and 2 (C) 1/4" Nuts. (Illustration 4)
7. Repeat step 6 for the other side.



Illustration 2



Illustration 3

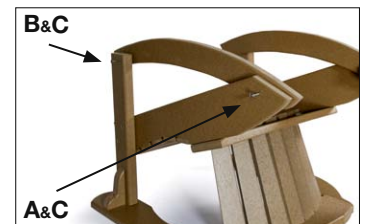

Illustration 4