

LiFePO4 Battery Specification

Model: PH1260



Contents

- 1. Normal performance**
- 2. Battery appearance structure & size**
- 3. Performance & Test Condition**
- 4. BMS technical parameters**
- 5. Storage and transportation**
- 6. Warning and tips**
- 7. Registration**
- 8. Warranty**
- 9. PowerHouse Lithium mobile phone App**

1. Normal performance:

NO.	Item	General Parameter	
1	Rated capacity	60Ah	
2	Standard voltage	12V (4S)	
3	Standard Charge voltage	14.6V	
4	Charging method	CC-CV	
5	Charge current	Normal	20A
		Max	40A
6	Cut-off voltage	10V	
7	Continuous discharge current	60A	
8	Peak discharge current	120A`	
9	Net weight	About 16.5lbs	
10	Impedance (Max, at 1000Hz.)	≤ 35 mΩ	
11	Charge method	charge	23°~140°F
		discharge	-4°~140°F
12	Storage environment	temperature	50°~113°F
		humidity	≤ 75%RH
13	Cycle life	1C@DOD100%	≥2500 cycles
		0.2C@DOD100%	≥4000 cycles
14	Self-discharge rate	≤3%/Month	
15	Battery dimension	L=7.79±0.08inches	
		W=6.53±0.08inches	
		H=6.69±0.08inches	

2. Battery appearance structure and size:

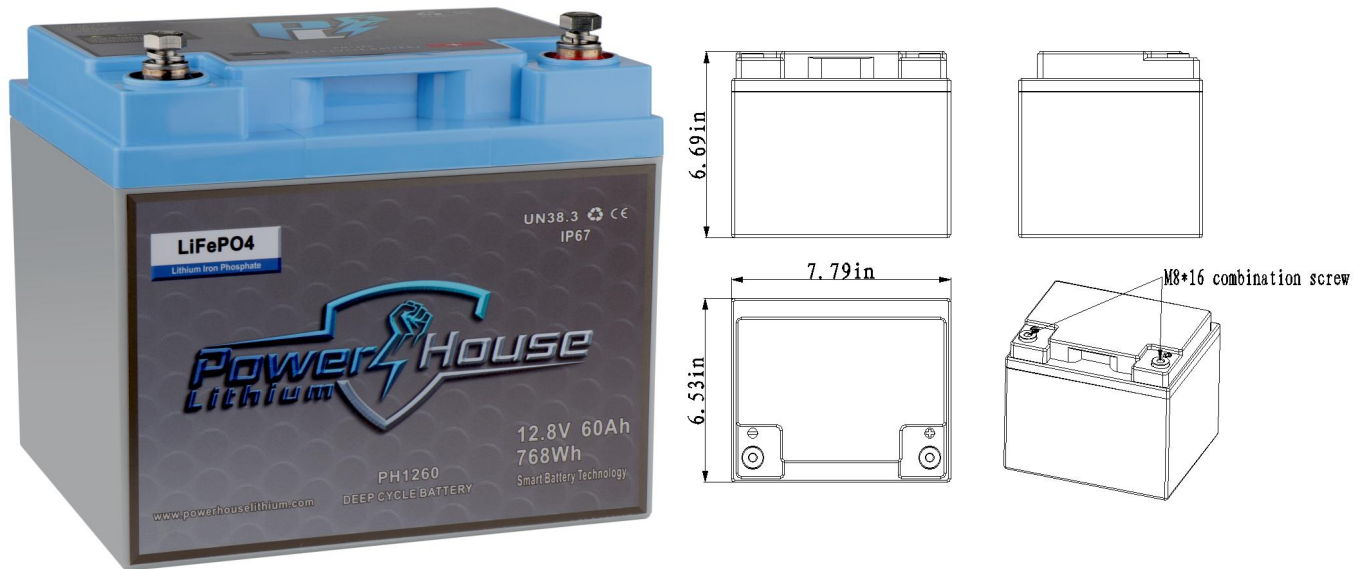

3. Performance & Test Condition:

No.	Project	Standard	Testing method								
1	Rated capacity	60Ah	After standard charge, discharge @0.5C current to the end of discharge voltage. cycle three times. One cycle capacity will show standard, that's to say it is passed Inspection and testing. (This is the same as below);								
2	Charging keep ability in normal temperature	Rest capacity \geq standard capacity *97%	After standard charging, store at 77°F±41°F for 1 month, and then discharge capacity @0.2C current to the end of discharge voltage. Then measure the capacity of cell.								
3	Cycle life	Capacity \geq Standard capacity *80%	After standard charge, discharge @0.2C current to the end of discharge voltage. rest for 1h, cycles for 4000 times.								
4	Internal Impedance	$\leq 35\text{m}\Omega$	@50% SOC @1kHz AC internal resistance test instrument.								
5	Discharge temperature characteristic @0.2C	<table border="1"> <tbody> <tr> <td>-4°F(6h)</td> <td>$\geq 70\%$</td> </tr> <tr> <td>32°F(6h)</td> <td>$\geq 90\%$</td> </tr> <tr> <td>77°F(4h)</td> <td>$\geq 100\%$</td> </tr> <tr> <td>131°F(4h)</td> <td>$\geq 97\%$</td> </tr> </tbody> </table>	-4°F(6h)	$\geq 70\%$	32°F(6h)	$\geq 90\%$	77°F(4h)	$\geq 100\%$	131°F(4h)	$\geq 97\%$	Capacity @specified temperature/Capacity @ 77°F
-4°F(6h)	$\geq 70\%$										
32°F(6h)	$\geq 90\%$										
77°F(4h)	$\geq 100\%$										
131°F(4h)	$\geq 97\%$										

4. BMS technical parameters:

1.The battery is designed with an intelligent protection board solution, which can monitor the battery running status in real time. The protection board has a strong loading capacity and the maximum discharge current can reach 40A. When abnormal, it provides overcharge, over discharge, over current, over temperature protection, etc. When the power battery input and output are actively cut off for protection. Features are as follows:

- 4-cell battery series protection
- Various protection functions for charging and discharging
- Hardware discharge overcurrent, short circuit protection function processing
- Software overvoltage, undervoltage, temperature, overload protection function processing
- Accurate SOC calculation with automatic learning SOC function
- Hardware discharge overcurrent, short circuit protection function processing
- With UART communication, support for Bluetooth.

2.The schematic diagram of the BMS control is as follows:

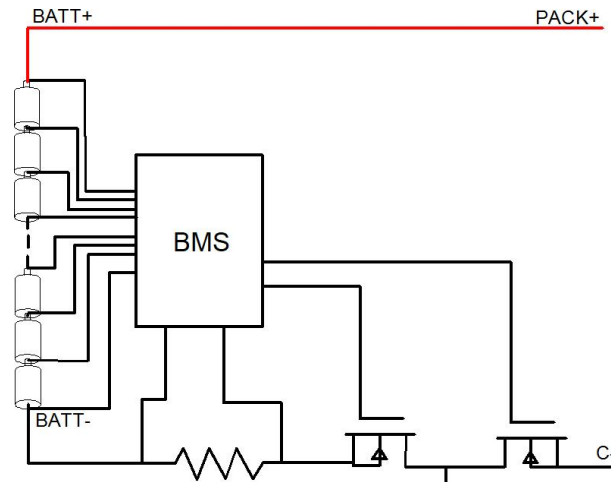

5. Storage and Transportation

1. Due to the nature of lithium ion, a proper environment for transportation of LiFePO₄ battery packs need to be created to protect the battery. Heavy duty box with padding is required. This eliminates damage to the case in shipping, that could cause water intrusion later.

2. During transportation, 50% SOC must be kept to ensure safety, liquid in the battery or immersion of battery in liquid never should occur.

3. Battery should be kept at 32°F~113°F in storage where it's dry, clean and well-ventilated.

4. During loading of battery, refrain from dropping the battery.

6. Warnings and Tips

Warning !

- Never throw the battery into water, keep it under dry, shady and cool conditions when not in use.
- Never reverse the positive and negative.
- Never connect the positive and negative of a battery with a conductive material.
- Never ship or store the battery together with other conductive materials
- Never knock, throw or trample the battery.
- Also make sure to check straps regularly and secure the battery in proper fitting trays.

NOTICE!

- Never use Battery over 113°F. Otherwise, it will cause excessive battery heat, this can cause fire, lose some function, or reduce the life of the battery. The proposed temperature for long-term storage is 32°-113°F.
- Never throw the battery into fire, explosion and environmental pollution will occur; scrap batteries should be handled by a recycle station.
- Never use the battery under strong static and strong magnetic field, otherwise it will destroy the BMS protecting device.
- If the battery emits a peculiar smell, heating, distortion or appears unconventionality during use, storage or charging process, please remove it from use and stop charging immediately.
- Please use only approved LiFePO4 charger when charging.
- Check the voltage of the battery and relevant connectors before using the battery. Do not put into operation unless levels are within specification.
- Prior to charging, fully check the battery condition and make sure it is secure in battery tray.
- The battery should be stored in half SOC. Fully charge the battery once every 6 months
- Clean the dirty electrode, if any, with a clean dry cloth, or poor contact or operation failure may occur.
- If the battery pack is used in series or in parallel, it must be ensured that the battery pack has the same charge and the pressure difference is within 50mV.

7. Registration

All batteries must be registered within 90 days of purchase failure to do so will result in battery prorated from battery production date. To register the battery, please go to:

<https://powerhouselithium.com/pages/registration>

8. Warranty

Starting batteries:

5-year warranty, first 3 years free replacement, unless it falls into the exclusions listed on the website. After year 3 the remaining warranty will be prorated by each month used.

Deep Cycles:

- 15 years total
- Repair or replace free any time inside of 60 months or 1,000 battery cycles (whichever comes first) from purchase date.
- All warrantied items will be subject to the shipping cost to and from PowerHouse Lithium.
- Warrantied replacement cost is based on current MSRP on all batteries over 1000 cycles or the 5 year period.

Replacement cost of batteries over the 5 year or 1000 cycle counts goes as followed:

1. From Year 5 thru 8 - repair: cost of parts plus \$100 (repair not to exceed 50% of MSRP), or replacement cost will be at a 50% discount off MSRP*. Cycle count not to exceed 1500 cycles

2. From year 8 thru 15 replacement cost will be at a 30% discount off current MSRP*

All shipping charges to and from Powerhouse Lithium are the responsibility of the consumer.

**** Note Life of a LiFePO4 battery will be reduced by not using the proper approved chargers.**

If warranty claim is necessary, please go to:

<https://powerhouselithium.com/pages/battery-warranty-claim>

to start this process

9. PowerHouse Lithium mobile phone APP

App supports Apple and Android platforms for the deep cycle batteries. The Bluetooth signal is strong and can be connected within 32 feet, if the signal is clear of obstructions.

All of our deep cycle batteries above 40AH are capable of connecting to the powerhouse lithium app, the monitoring app can be found on google play store for Android and the App Store for iPhone by searching Powerhouse Lithium



**PowerHouse
Lithium**