

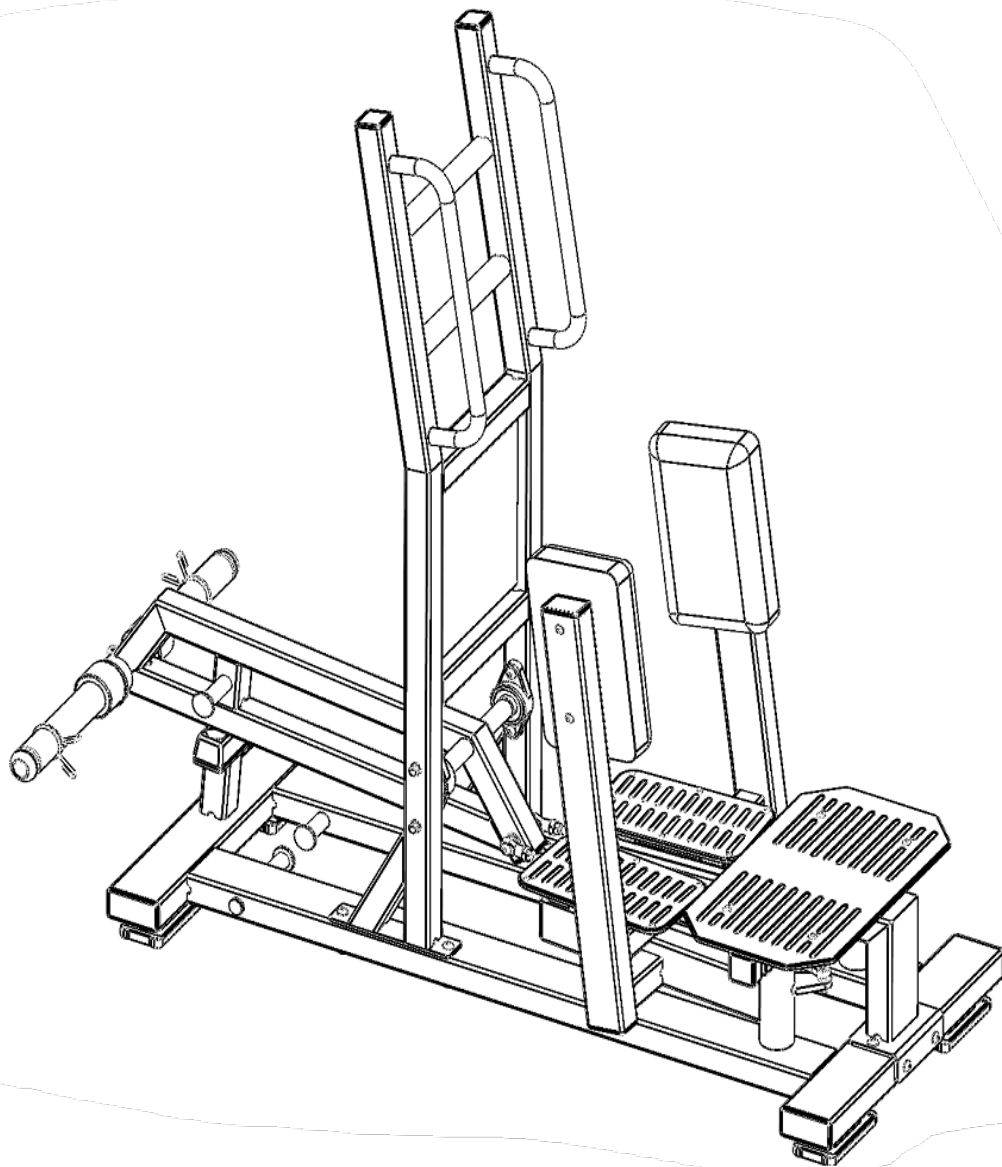

Excel Standing Hip Abductor Assembly Instruction

PL-ST-AB





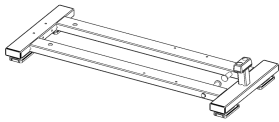
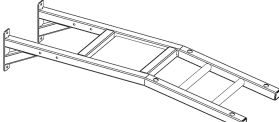
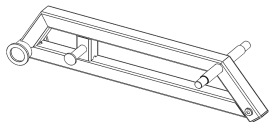
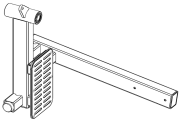
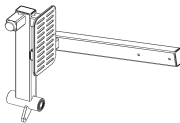
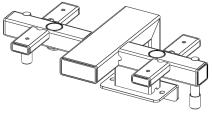
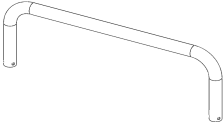
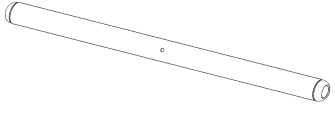
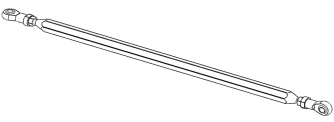
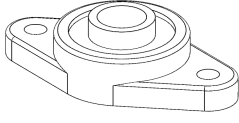
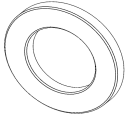
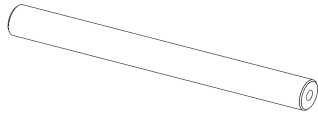
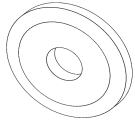
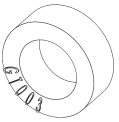
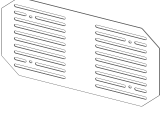
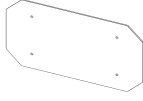
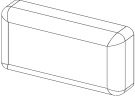
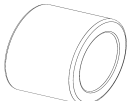

Parts list (individually packaged)

		
1	2	3
		
4	5	6
		
7	8	9
		
10	11	12
		
13	14	15
		
16	17	18

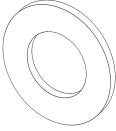
Item NO	Name	Qty
1	Base assembly	1
2	Column components	1
3	Starter arm assembly	1
4	Left boom assembly	1
5	Right boom assembly	1
6	Pedal components	1
7	handle assembly	2
8	Stainless steel components	1
9	Connect bearing assembly	2
10	Bearing seat	2
11	Spacer sleeve	2
12	Connecting shaft	2
13	0211 gasket	2
14	GT003	4
15	Stainless steel foot pedal 2	1
16	Assemble the pedals	1
17	Leg pads	2
18	New sheath	2
19	50 Diameter butterfly clip	2

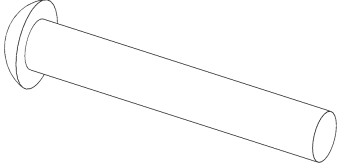
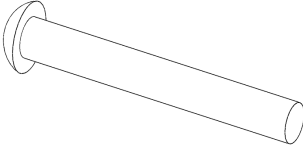
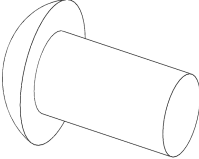
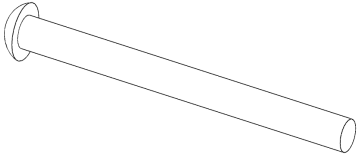
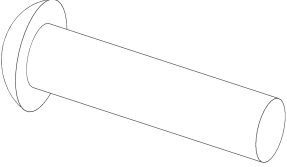
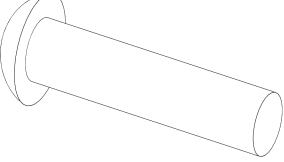
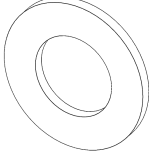
Blister package screw list

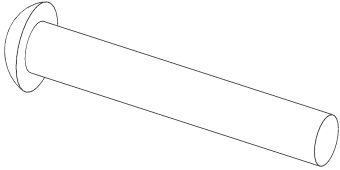
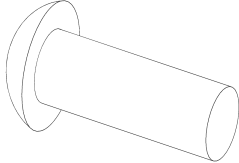
		
A	B	C
		
D	E	F
		
G	H	J
		
K	L	M
Item NO	Name	Qty
A	Flat washer Φ 10	33
B	Lock nut M10	14
C	Hexagon socket head screw M10X70	6
D	Hexagon socket head screw M10X80	4
E	Hexagon socket head screw M10X20	9
F	Hexagon socket head screw M10X120	2
G	Hexagon socket head screw M10X45	2
H	Hexagon socket head screw M8X45	4
J	Flat washer Φ 8	8
K	Lock nut M8	4
L	Hexagon socket head screw M8X70	4
M	Hexagon socket head screw M10X30	2
N		

Assembly steps

Step	Item NO	Name	Qty
1	1	Base assembly	1
	3	Column components	1
	A	Flat washer $\Phi 10$	8
	B	Lock nut M10	4
	C	Hexagon socket head screw M10X70	4

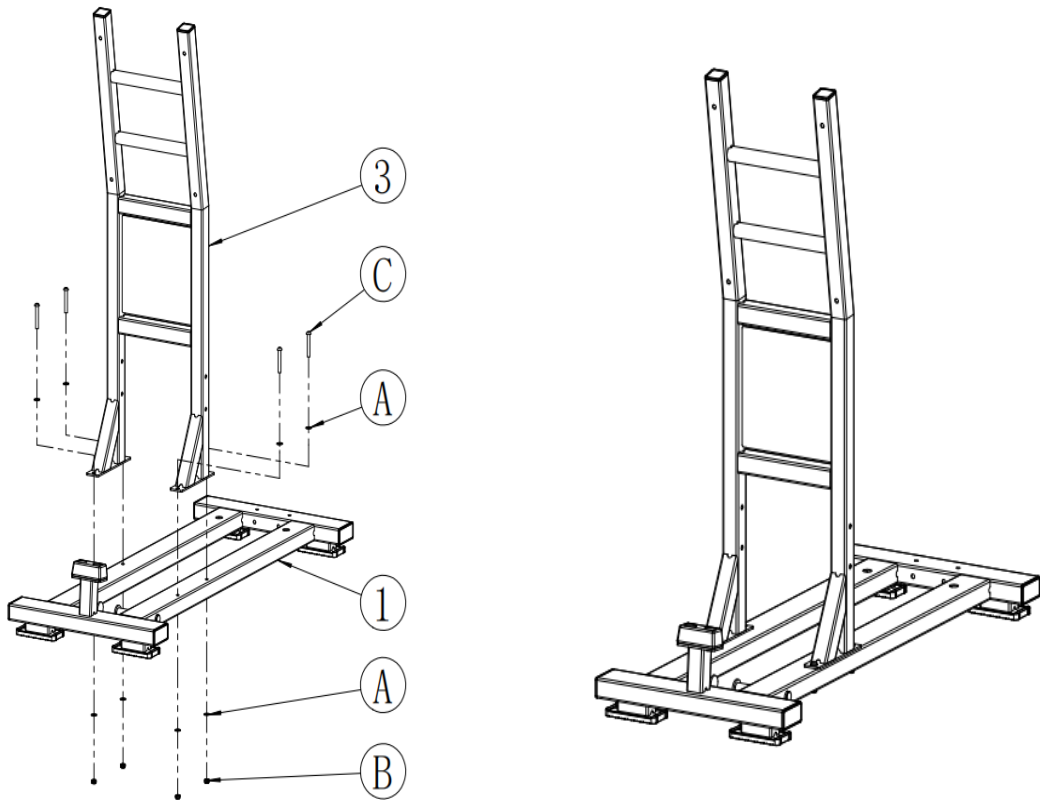

Assembly steps

Step	Item NO	Name	Qty
2	3	Starter arm assembly	1
	10	Bearing seat	2
	A	Flat washer $\Phi 10$	8
	B	Lock nut M10	4
	D	Hexagon socket head screw M10X80	4

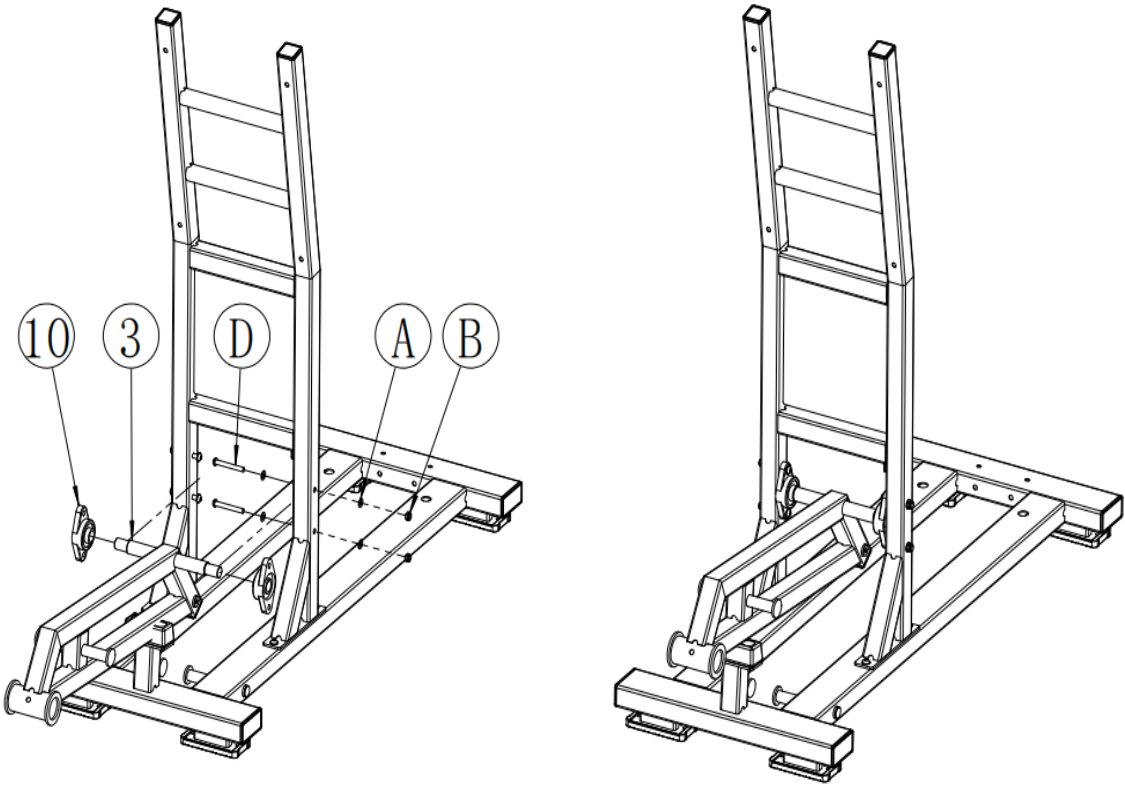

Assembly steps

Step	Item NO	Name	Qty
3	4	Left boom assembly	1
	5	Right boom assembly	1
	11	0217 spacer sleeve	2
	12	Connecting shaft	2
	A	Flat washer $\Phi 10$	2
	E	Hexagon socket head screw M10X20	2

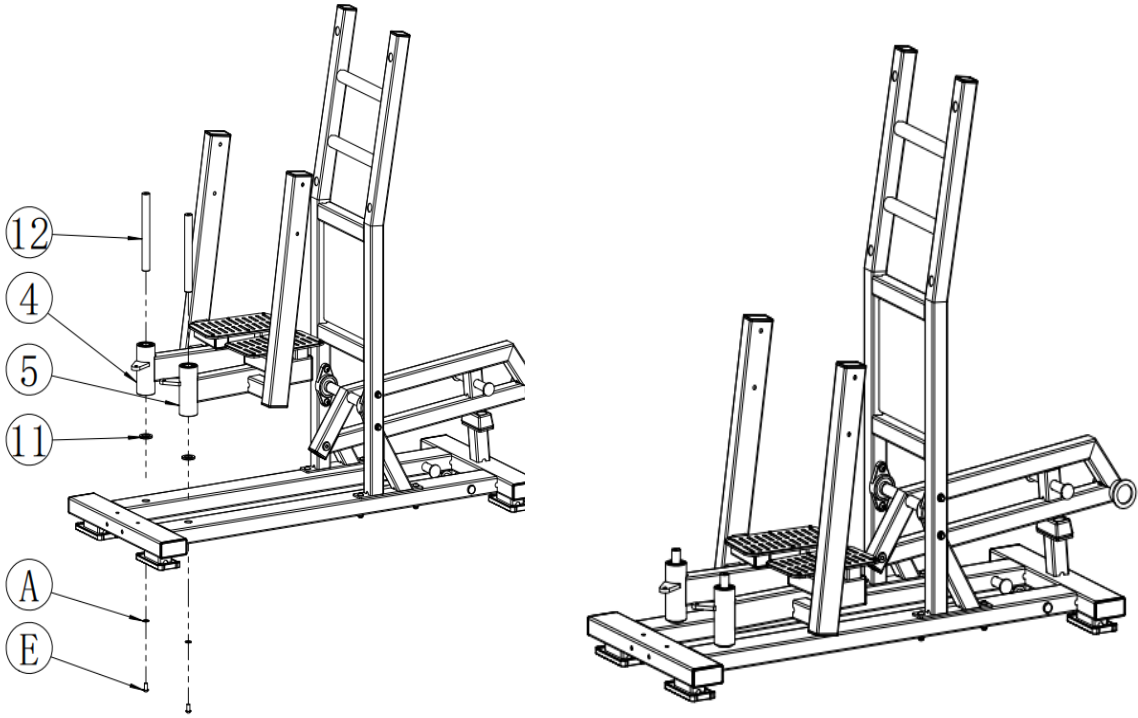

Assembly steps

Step	Item NO	Name	Qty
4	6	Pedal components	1
	13	0211 gasket	2
	A	Flat washer $\Phi 10$	8
	B	Lock nut M10	4
	C	Hexagon socket head screw M10X70	2
	E	Hexagon socket head screw M10X20	2
	F	Hexagon socket head screw M10X120	2

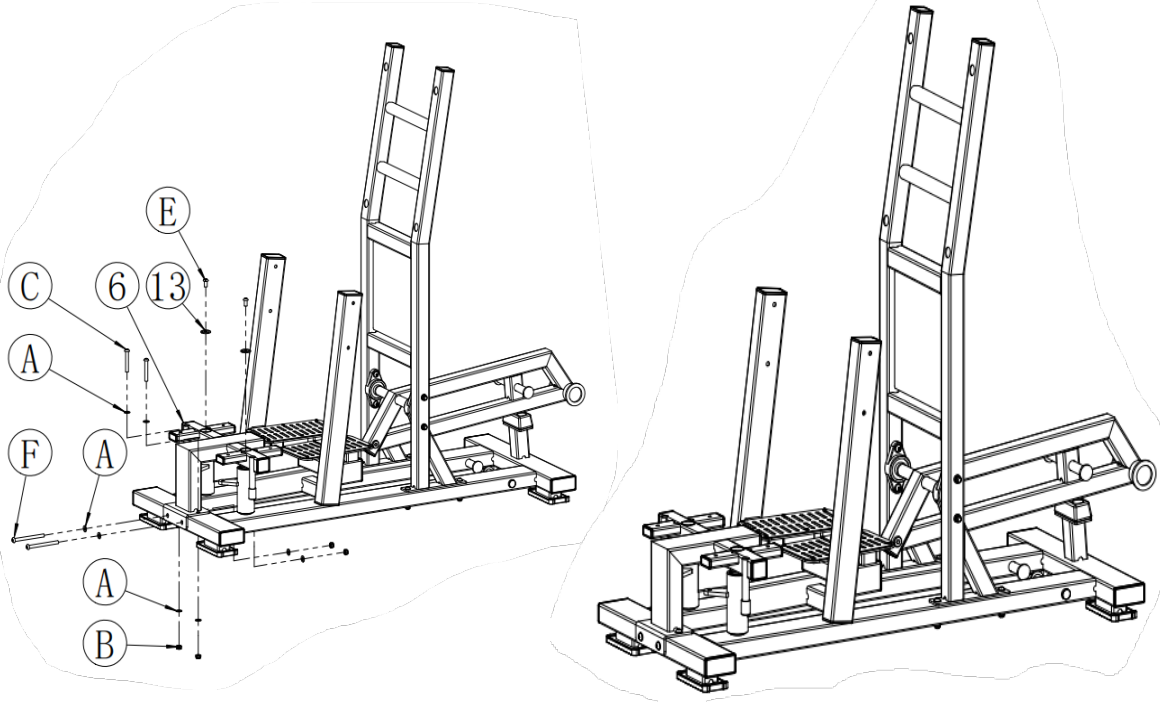

Assembly steps

Step	Item NO	Name	Qty
5	9	Connect bearing assembly	2
	14	GT003 spacer sleeve	4
	A	Flat washer $\Phi 10$	2
	B	Lock nut M10	2
	G	Hexagon socket head screw M10X45	2
	M	Hexagon socket head screw M10X30	2

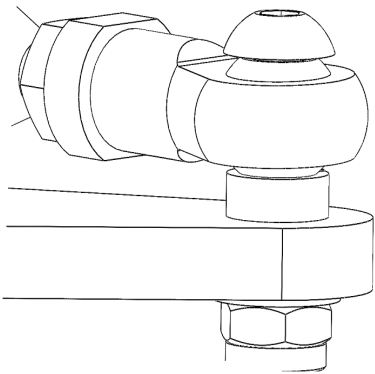

14

14

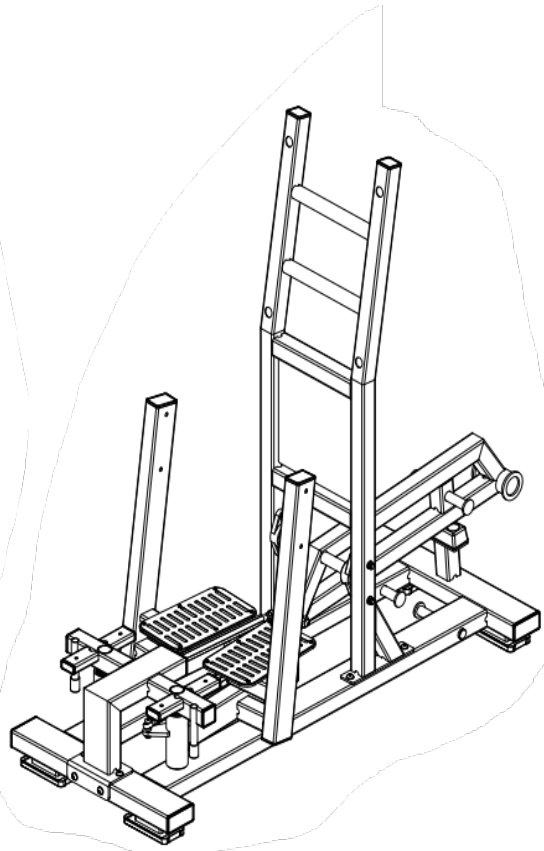
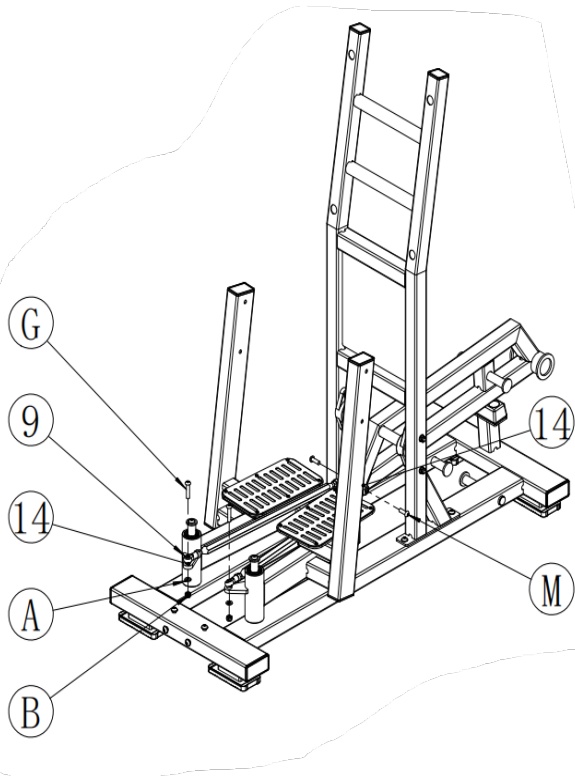
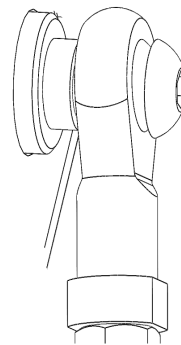

Assembly steps

Step	Item NO	Name	Qty
6	7	Handle assembly	2
	15	Stainless steel foot pedal 2	1
	16	Assemble the pedals	1
	A	Flat washer $\Phi 10$	4
	E	Hexagon socket head screw M10X20	4
	J	Flat washer $\Phi 8$	4
	H	Hexagon socket head screw M8X45	4
	K	Lock nut M8	4

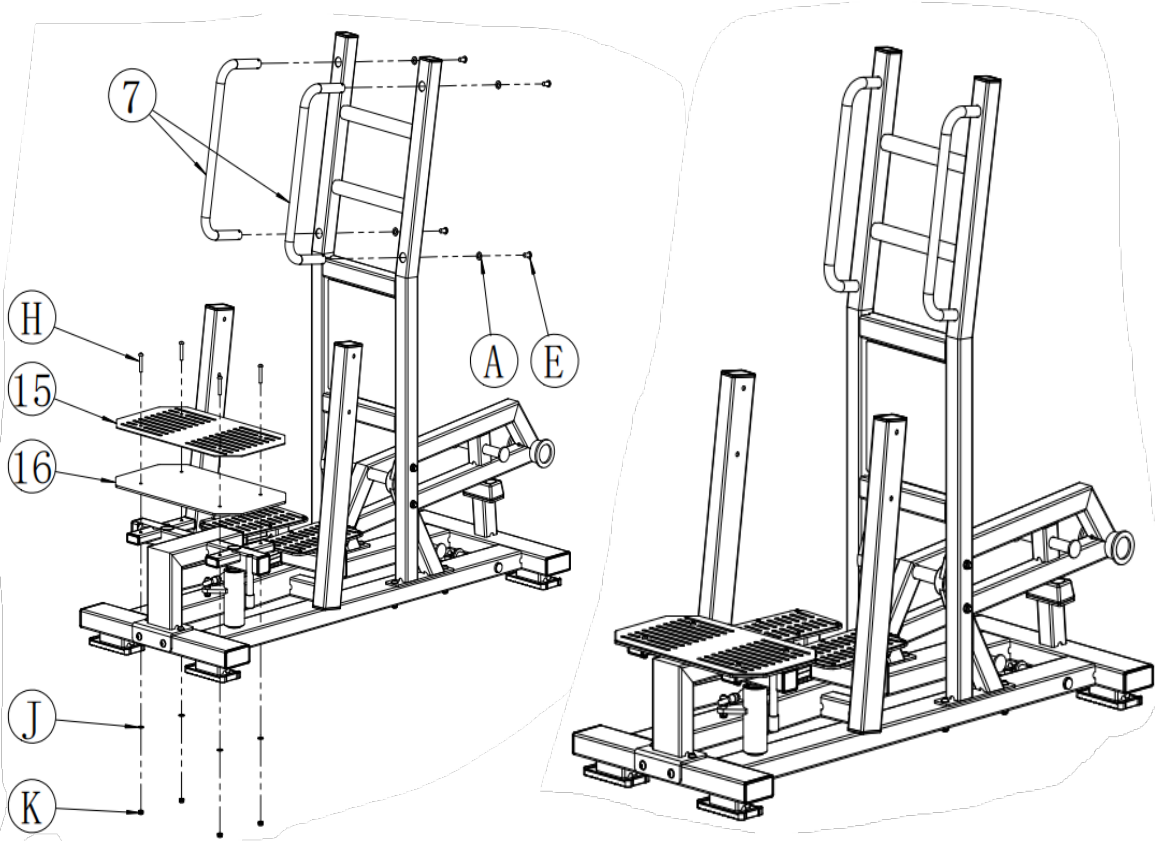

Assembly steps

Step	Item NO	Name	Qty
7	17	Leg pads	2
	J	Flat washer $\Phi 8$	4
	L	Hexagon socket head screw M8X70	4

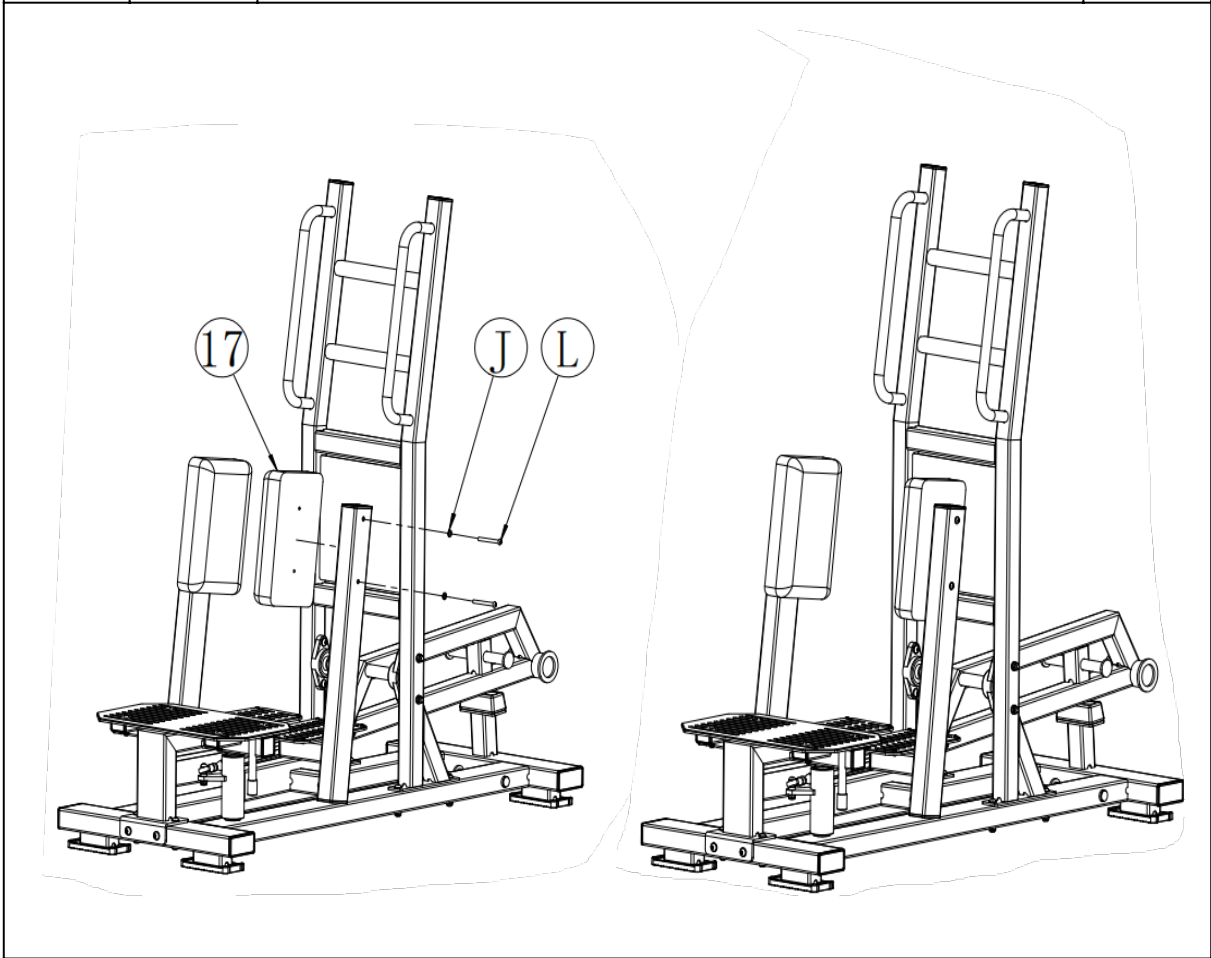

Assembly steps

Step	Item NO	Name	Qty
8	8	Stainless steel components	1
	18	0609 New sheath	2
	19	Butterfly clip	2
	A	Flat washer $\Phi 10$	1
	E	Hexagon socket head screw M10X20	1

