

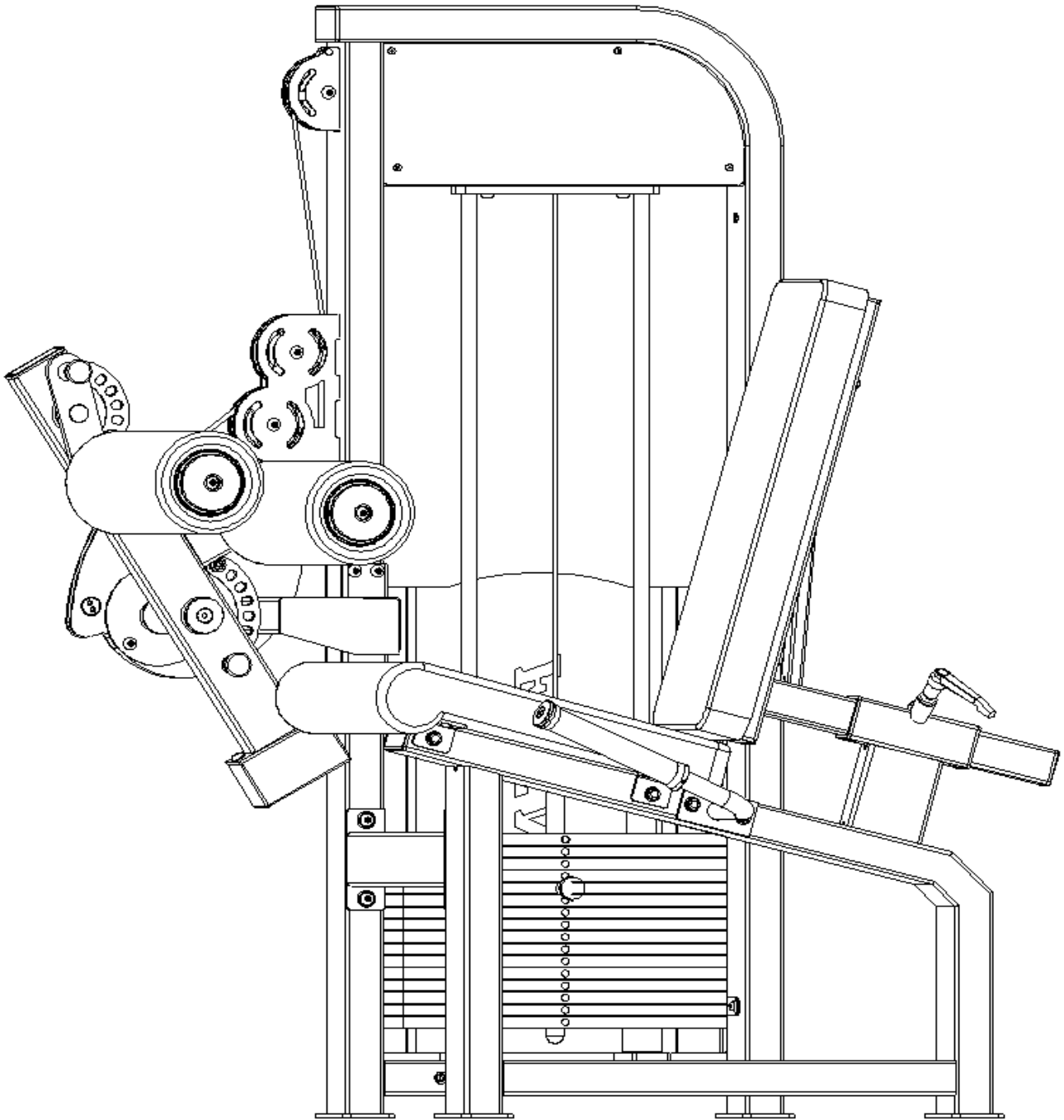

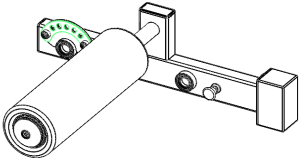

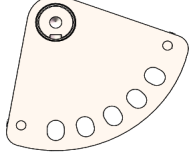

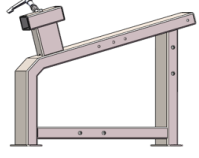

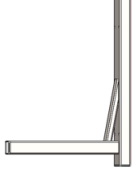
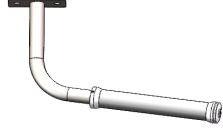
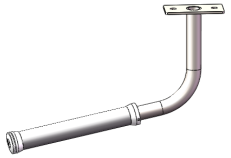
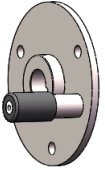
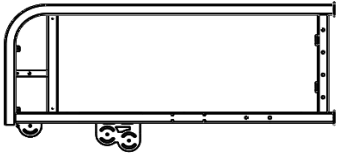
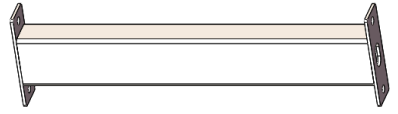
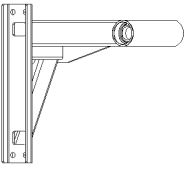
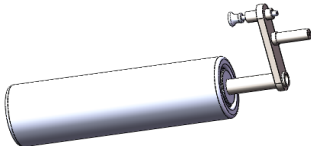
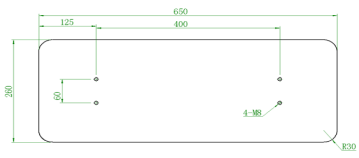
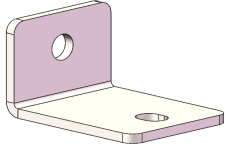
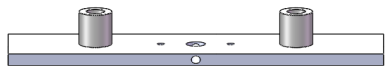
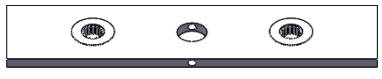

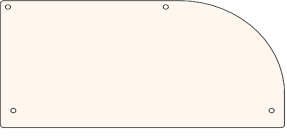

GC-5001 Seated Leg Curl

Installation Standard Instructions

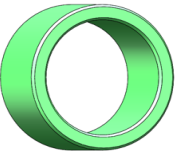
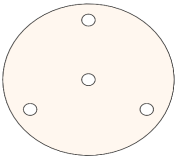
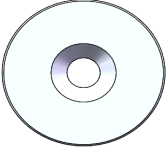

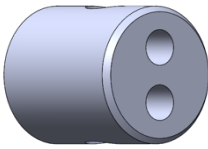
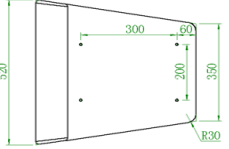

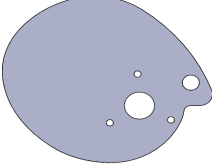
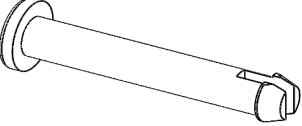
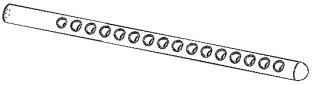
Parts list (individually packaged)

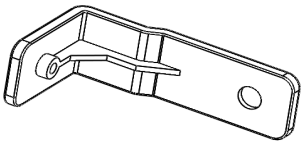
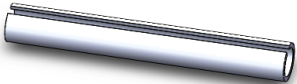
					
No.1	Boom assembly*1pc	No.2	big reel*1pc	No.3	Large frame welded components*1pc
					
No.4	Backrest welding components*1pc	No.5	Handle Welding Assembly Right*1pc	No.6	Handle Welding Assembly Left*1pc
					
No.7	Steering pulley welding assembly*1pc	No.8	Small door welding components*1pc	No.9	lower connection components*2pcs
					
No.10	Bracket Welding Assembly*1pc	No.11	Foam Rod Assembly*1pc	No.12	Large backrest assembly*1pc
					
No.13	Cushion Mounting Plate*4pcs	No.14	Counterweight assembly*1pc	No.15	Weight stack*15pcs
					
No.16	Cover*1pc	No.17	label board*2pcs	No.18	rubber column*2pcs

					
No.19	Optical axis fixing block*1pc	No.20	Φ20*1217mm guide rod*2pcs	No.21	Powder metallurgy sleeve*1pc
					
No.22	rope reel cover*1pc	No.23	Aluminum alloy end cap Φ50*10mm*2pcs	No.24	lock plate*1pc
					
No.25	Fixed cable cylinder*1pc	No.26	Cushion*1pc	No.27	Φ105Pully*4pcs
					
No.28	ordinary flat key*1pc	No.29	rope reel*1pc	No.30	rope pin*2pcs
					
No.31	15 hole center rod*1pc	No.32	Counterweight Latch*1pc	No.33	Cable*1pc
					
No.34	small mounting plate*4pcs	No.35	cotter pin*1pc		

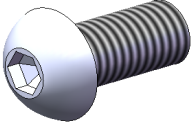
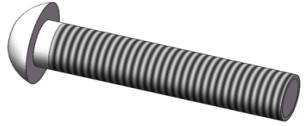
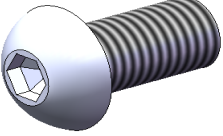
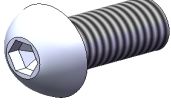
Blister Pack List

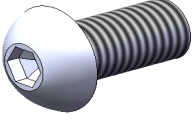
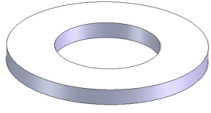
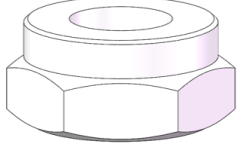
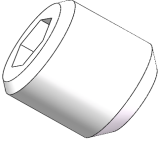
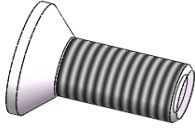
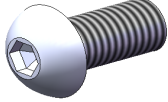
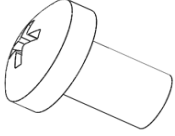
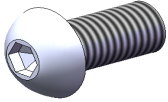
					
A	Hexagon socket head screws M10*120*8pcs	B	Hexagon socket head screws M10*20*1pc	D	Hexagon socket head screws M10*45*7pcs
					
D	Hexagon socket head screws M10*30*2pcs	E	Hexagon socket head screws M10*16*1pc	F	Hexagon socket head screws M8*60*4pcs
					
G	Hexagon socket head screws M10*25*8pcs	H	Φ10 Gasket*24pcs	I	M10 Locknut*15pcs
					
J	M8*12 top wire*2pcs	K	M10*25 Countersunk Head Screws*2pcs	L	M8*25 Flat head screws*4pcs
					
L1	Hexagon socket head Phillips head screws M5*8* 12pcs	P	M8*20 Flat head screws*4pcs		

Assembly steps

Step	Item No.	Name	Quantity	Item No.	Name	Quantity
1	No.8	Small door welding components	1	G	M10*25 Hexagon socket head screws	8
	No.9	lower connection components	2			
	No.3	Large frame welded components	1	H	Φ10 Gasket	8

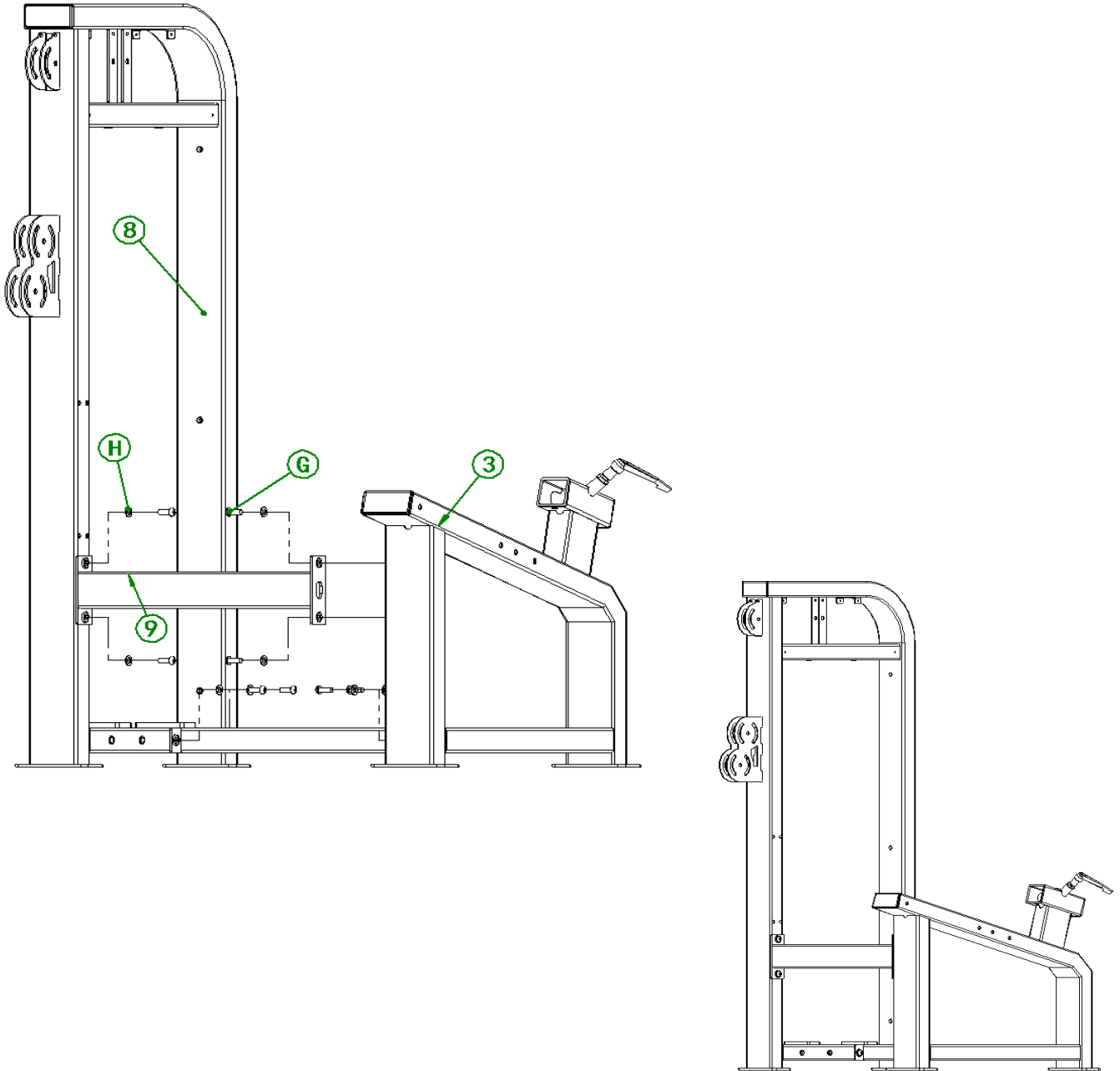

No. 8 Small door welding components*1pc

Step	Item No.	Name	Quantity	Item No.	Name	Quantity
	No.43	50*100 Square tube plug	1	Q	M10 rivet nut	8
				M	M8 rivet nut	6

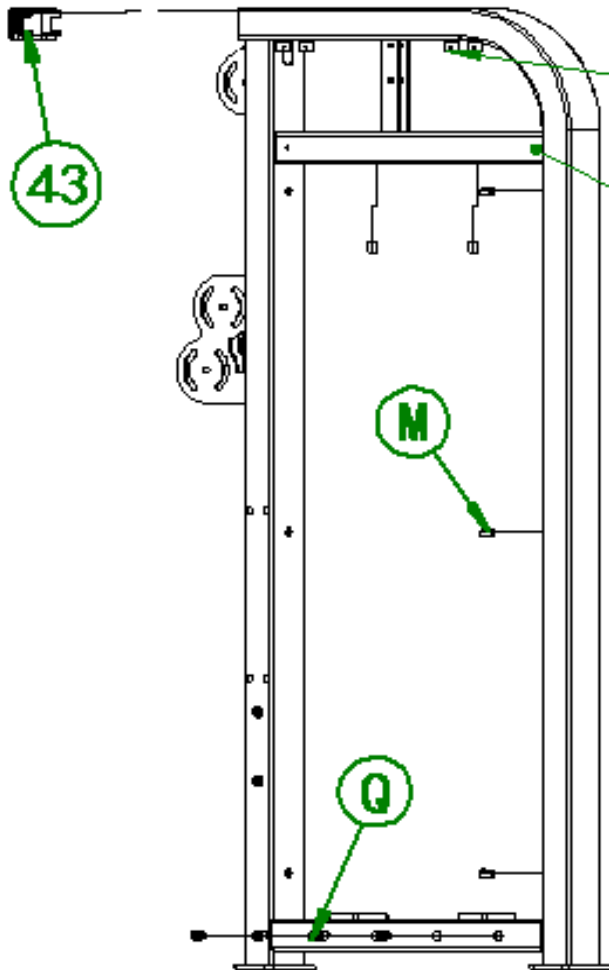

Both sides need to be buckled

Both sides need to be buckled

No.3 Large frame welded components*1pc

Step	Item No.	Name	Quantity	Item No.	Name	Quantity
	No.65	Reducer	2	No.68	top post	1
	No.66	Rotary handle	1	No.43	50*100 Square tube plug	1
	No.67	Hexagon lock nut	1	Q	M10 rivet nut	4

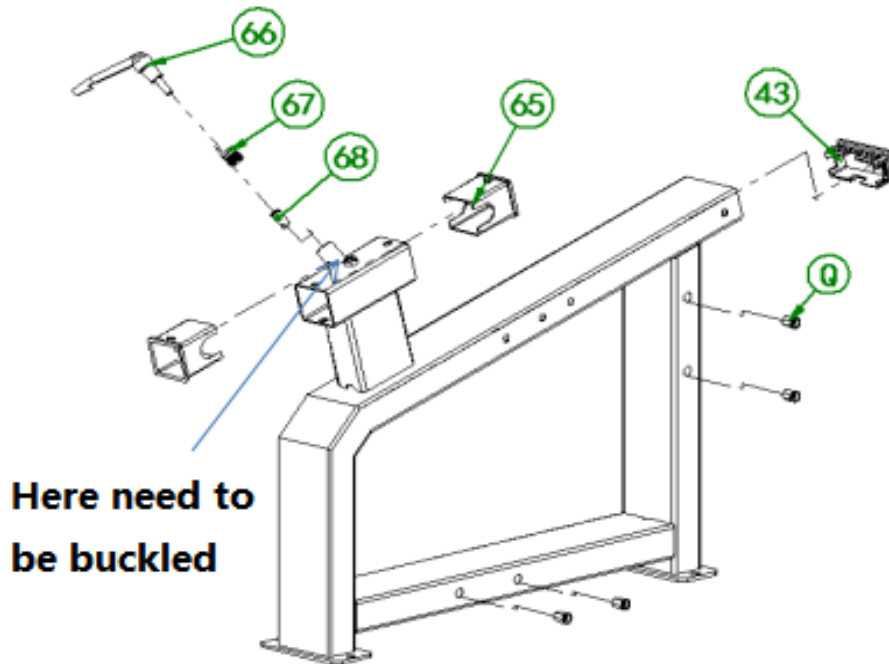

Assembly steps

Step	Item No.	Name	Quantity	Item No.	Name	Quantity
2	No.24	lock plate	1	No.29	rope reel	1
	No.22	rope reel cover	1	No.10	Bracket assembly	1
	No.25	Fixed cable cylinder	1	No.28	8*25Flat key	1
	A	M10*120Flat head screws	4	No.21	Powder metallurgy sleeve	1
	H	Φ10 Gasket	8	No.2	Large shaft assembly	1
	E	M10*16 Flat head screws	1	No.7	Steering pulley assembly	1
	J	8*12 top wire	2	I	M10 Locknut	7
	C	M10*45 Flat head	3			

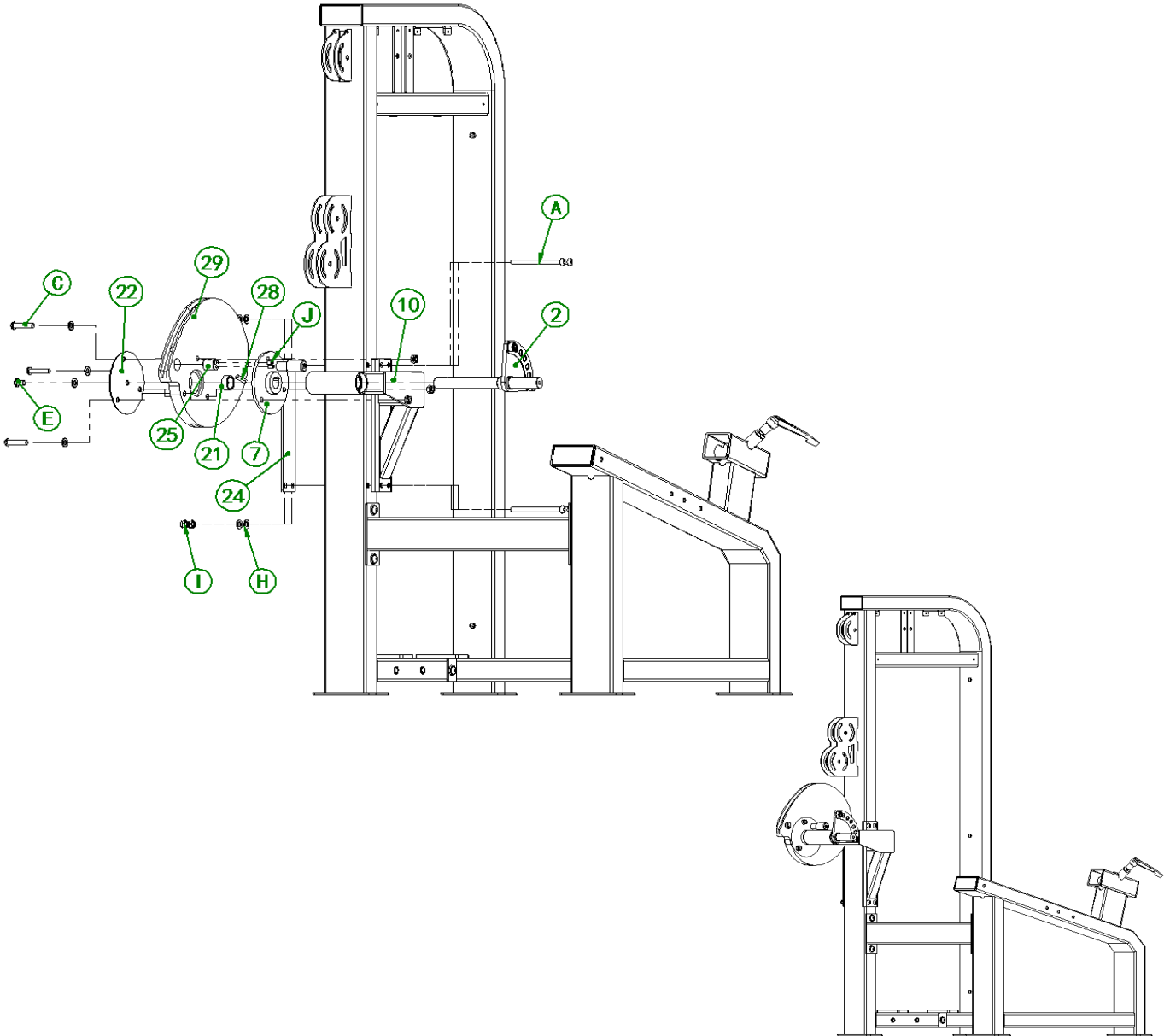

No.2 Large shaft assembly*1pc

Step	Item No.	Name	Quantity	Item No.	Name	Quantity
	No.40	Limit sleeve	2	N	M8*12 Cylinder head screws	2
	No.41	Stainless Steel Adjustment Sheet Metal	1			

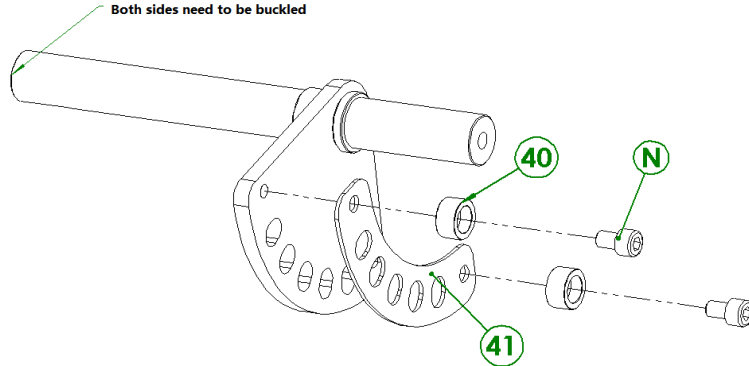

No.10 Bracket assembly*1pc

Step	Item No.	Name	Quantity	Item No.	Name	Quantity
	No.55	61905 bearing	2			

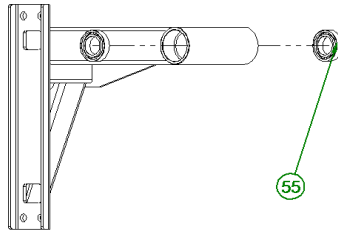

NO.7 Steering pulley assembly*1pc

Step	Item No.	Name	Quantity	Item No.	Name	Quantity
	No.60	Smith Sheath	1			
	T	M5*10 Countersunk Head Screws	1			

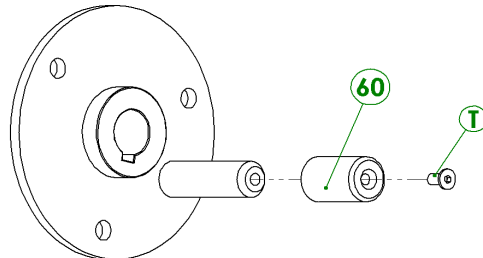

Assembly steps

Step	Item No.	Name	Quantity	Item No.	Name	Quantity
3	No.23	Aluminum alloy end cap	2	K	M10*25 Countersunk Head Screws	2
	No.11	Foam rod welding components	1	No.1	Boom assembly	1

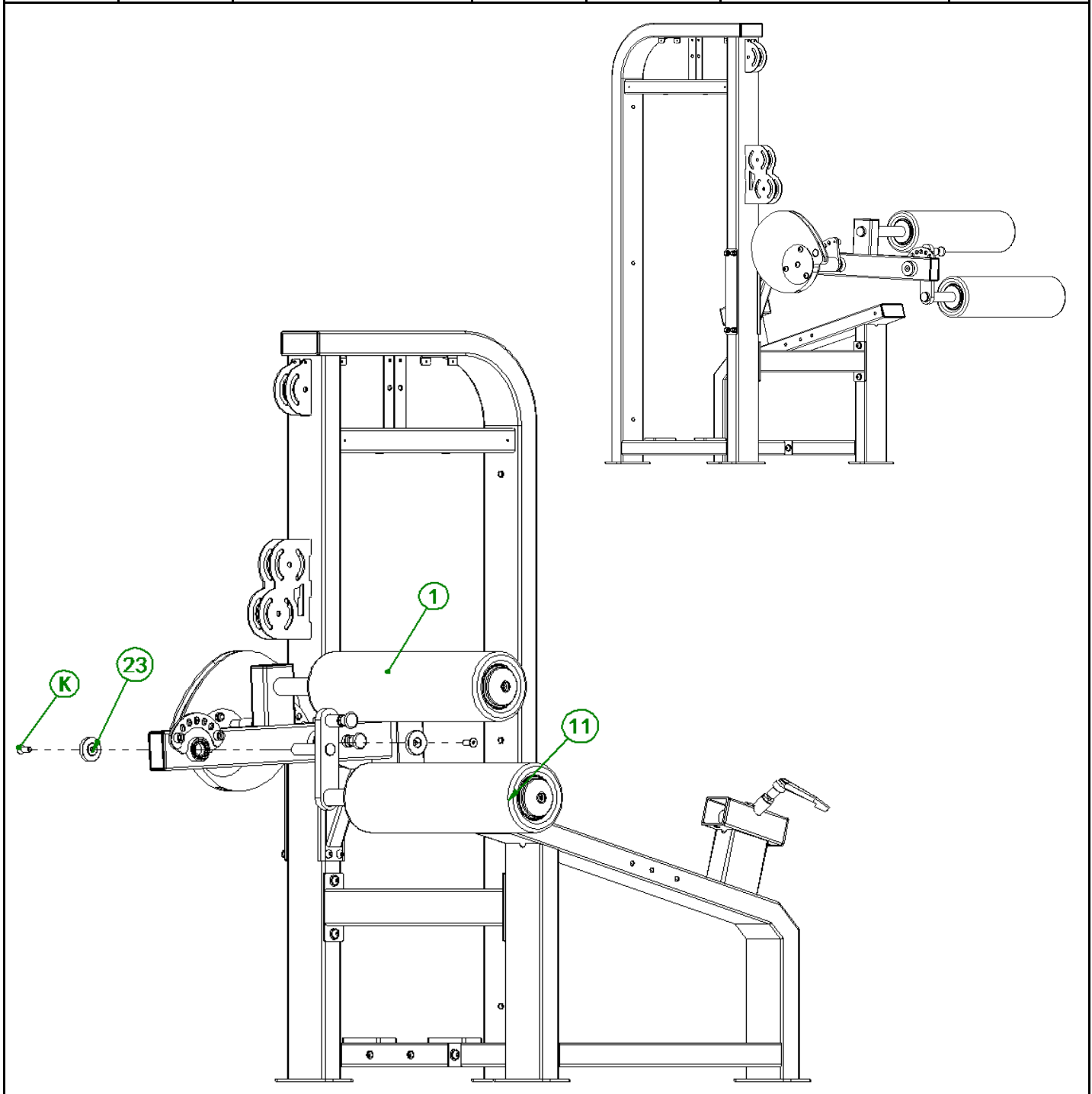

NO.11 Foam Rod Assembly*1pc

Step	Item No.	Name	Quantity	Item No.	Name	Quantity
	No.37	Aluminum alloy spring pin	1	D	M10*30 Flat head screws	1
	No.38	plug	1	S	M10 star nut	1
	No.39	spring	1	No.57	foam roller	1
	No.69	Φ32 Round pipe plug	1	No.58	Foam end cap	1
	No.70	No.96 plastic parts	2	L2	5*13 Countersunk Head Screws	12

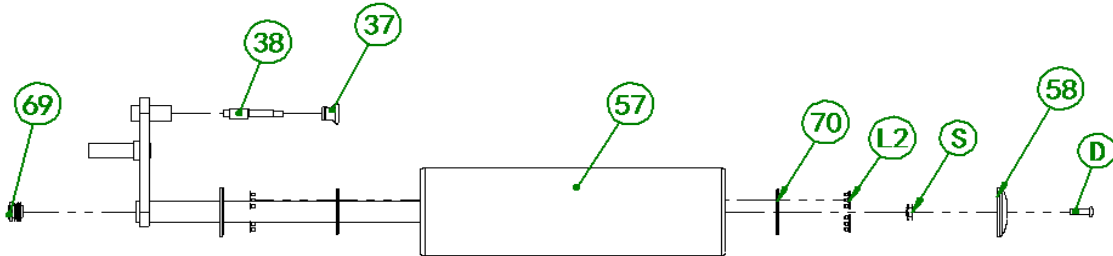

No.1 Boom assembly*1pc

Step	Item No.	Name	Quantity	Item No.	Name	Quantity
	No.45	Counterweight	1	No.42	40*80 Silencer	2
	No.55	61905 Bearing	4	No.37	Aluminum alloy spring pin	1
	No.44	Stainless steel adjustment plate 5 holes	1	No.57	foam roller	1
	No.40	limit trap	2	No.58	Foam end cap	1
	No.39	Spring	1	S	M10 star nut	1
	No.38	Plug	1	D	M10*30 Flat head screws	1
	N	M8*12 Cylinder head screws	2	H	Φ10Gasket	2
	E	M10*16 Flat head screws	2	No.69	Φ32 Round pipe plug	1
	No.70	No.96 plastic parts	2	L2	5*13 Countersunk Head Screws	12

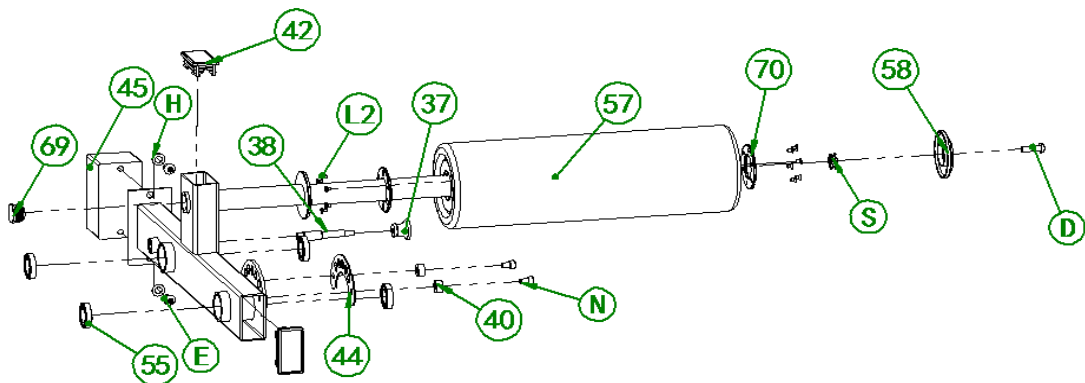

Assembly steps

Step	Item No.	Name	Quantity	Item No.	Name	Quantity
4	No.14	Counterweight assembly	1	No.18	round rubber column	2
	No.20	guide rod	2	No.30	rope pin	2
	No.31	center rod	1	No.27	Φ105Pully	4
	No.15	Weight stack	15	H	Φ10 Gasket	4
	No.32	Counterweight Latch	1	D	M10*30 Flat head screws	2
	No.19	Optical axis fixing block	1	No.35	10*70 cotter pin	1
	C	M10*45 Flat head screws	4	I	M10 Locknut	4

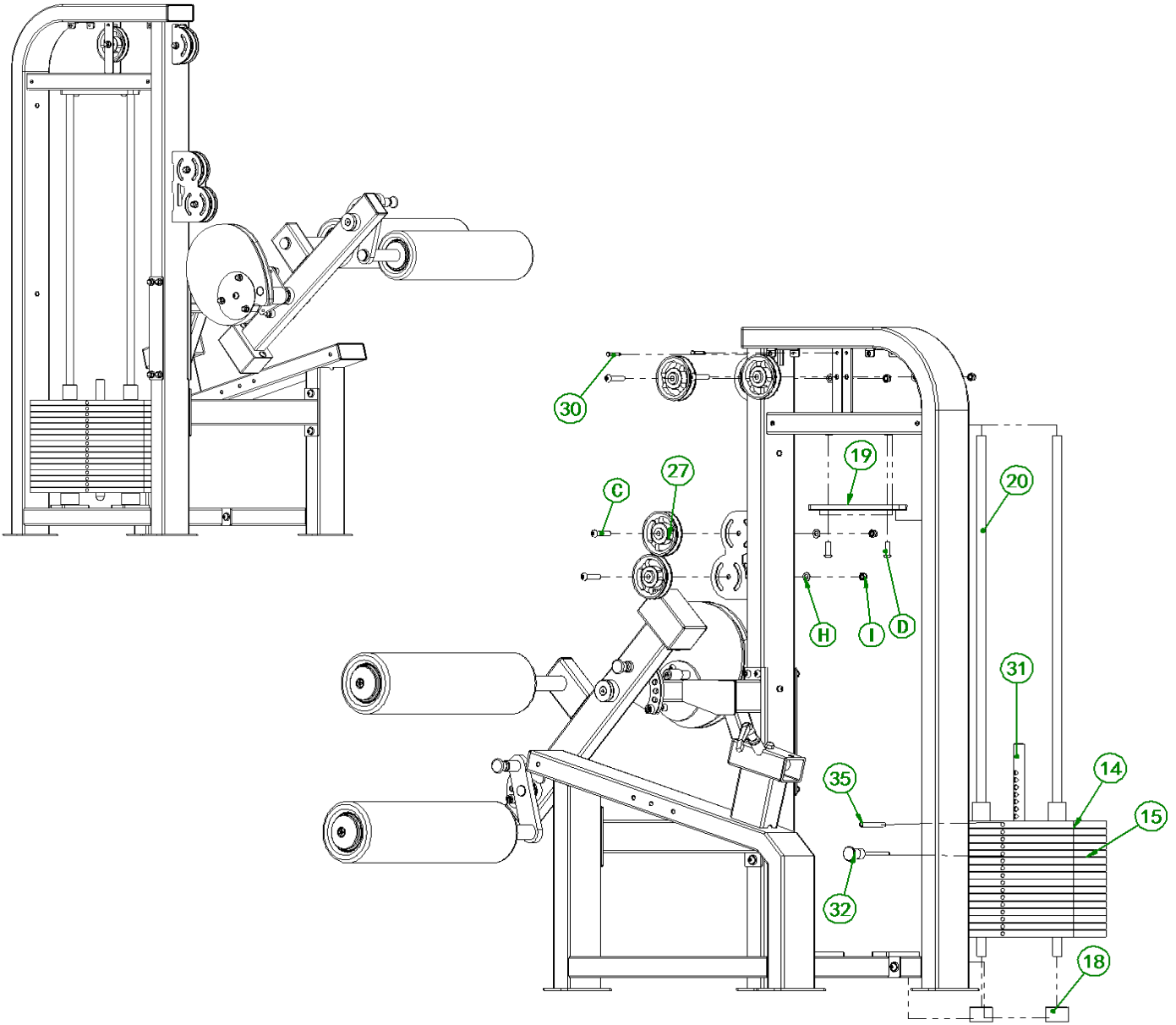

Assembly steps

Step	Item No.	Name	Quantity	Item No.	Name	Quantity
5	No.33	Cable	1			

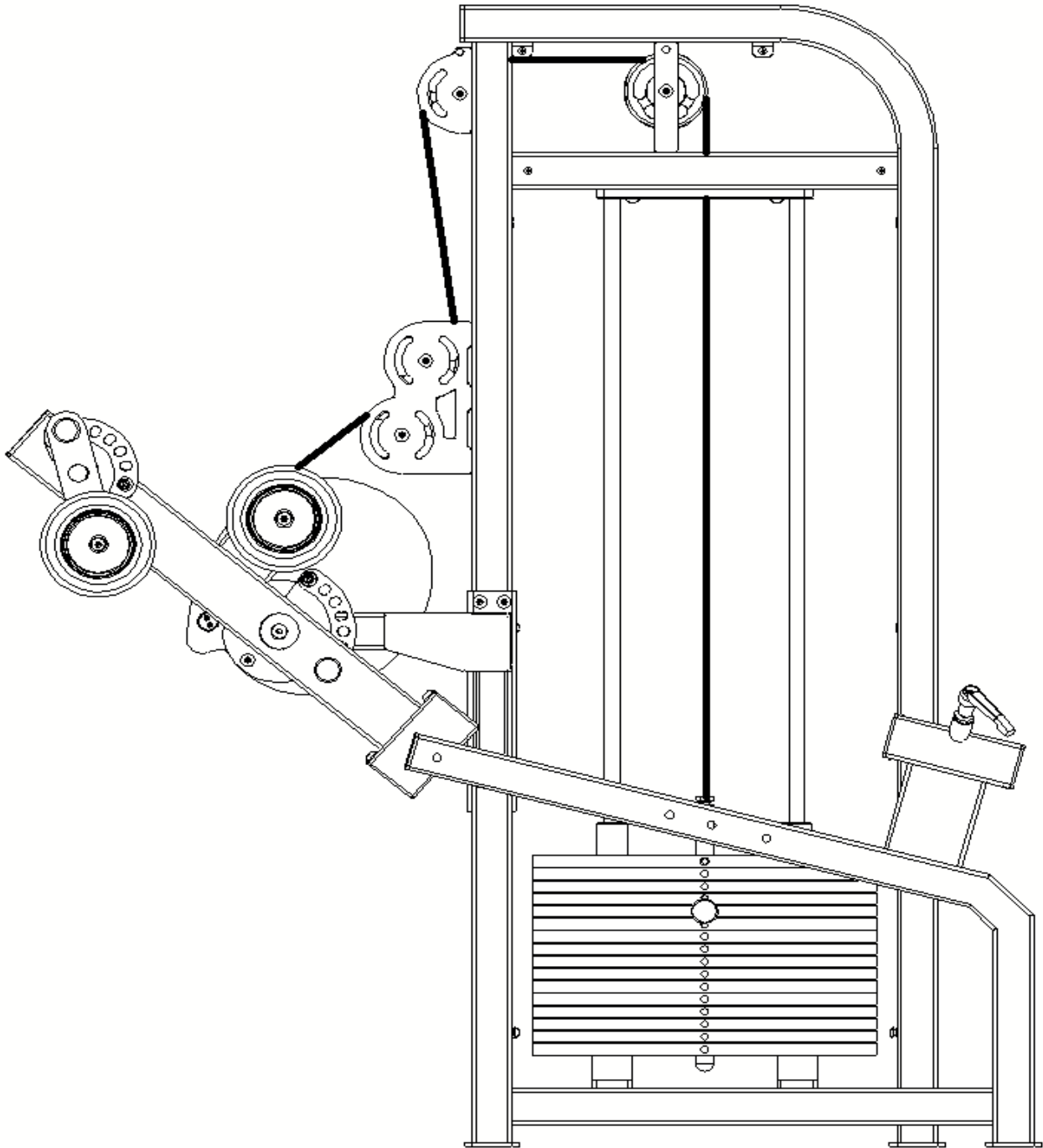

Wire rope routing diagram

Assembly steps

Step	Item No.	Name	Quantity	Item No.	Name	Quantity
6			1	No.6	Handle welding group left	1
			4	H	Φ10Gasket	2
	No.4	Backrest components	1	I	M10Locknut	2
	No.5	Handle welding group right	1	B	M10*20 Flat head screws	1
			4	A	M10*120 Flat head screws	2

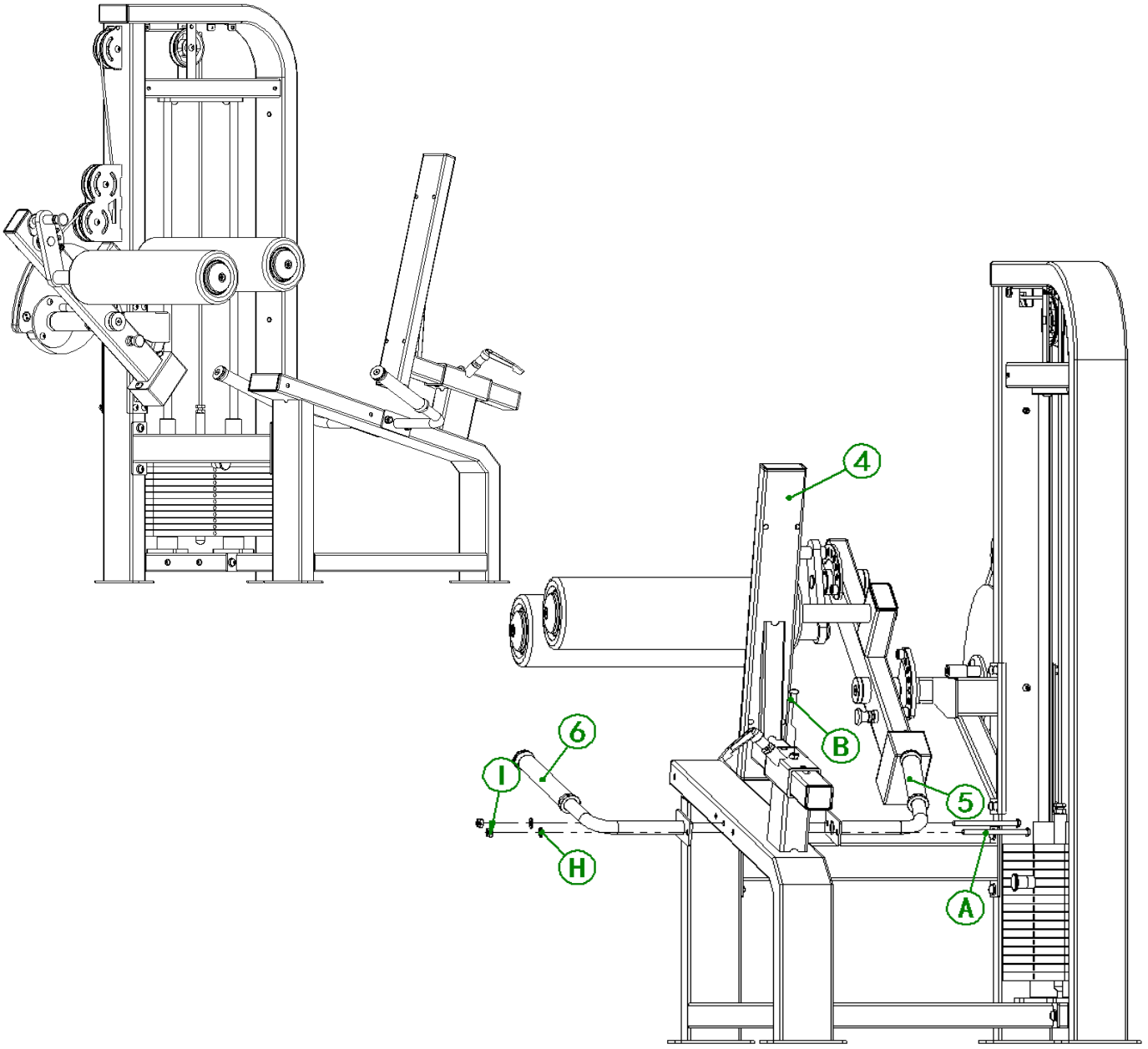

Assembly steps

Step	Item No.	Name	Quantity	Item No.	Name	Quantity
7	No.12	large backrest	1	L	M8*25 Flat head screws	4
	No.13	Install the cushion plate	4	F	M8*60 Flat head screws	4
	No.26	Cushion	1	A	M10*120 Flat head screws	2
	I	M10 Locknut	2	H	Φ10 Gasket	2

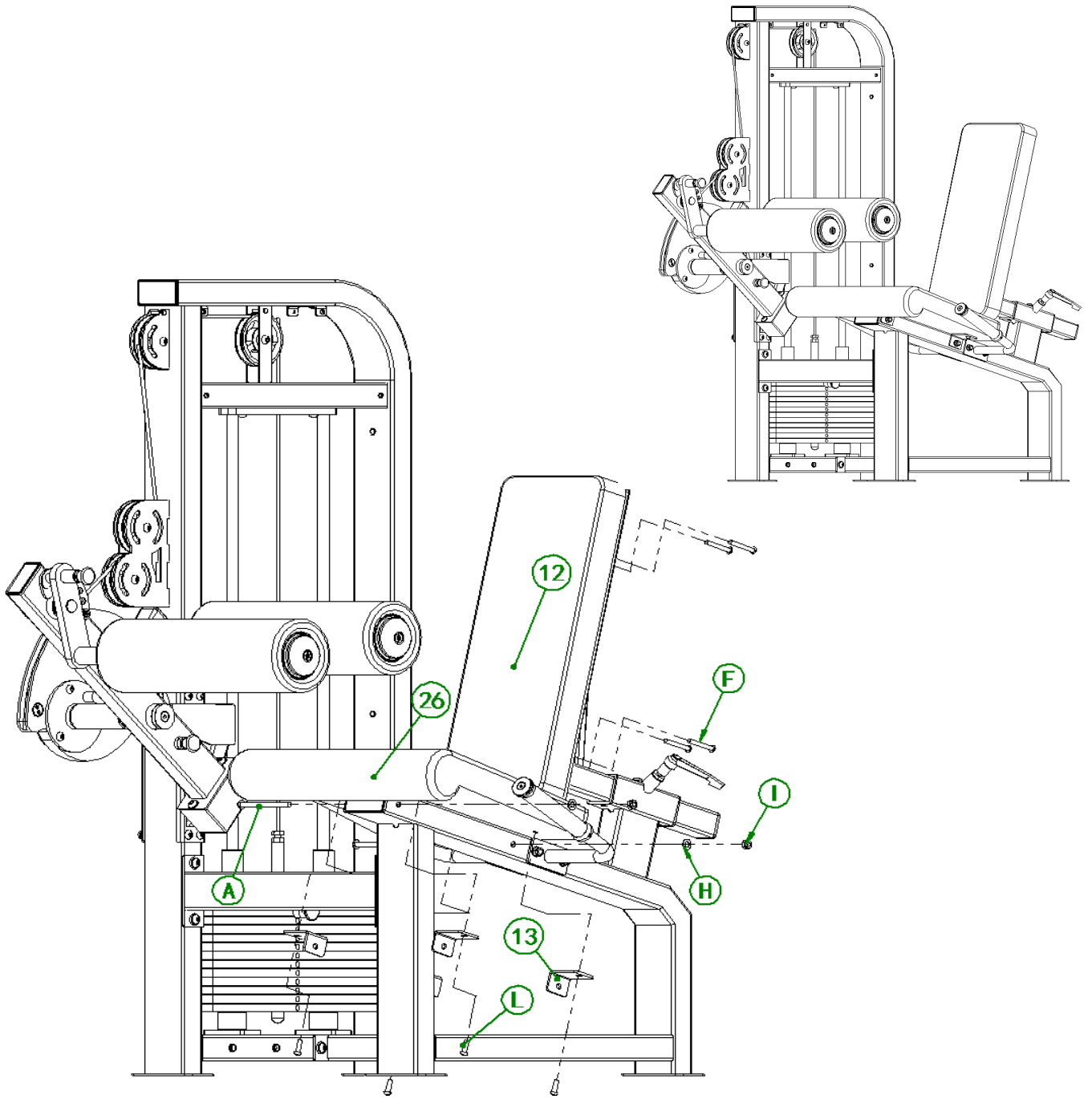

No.4 Backrest components*1pc

Step	Item No.	Name	Quantity	Item No.	Name	Quantity
	No.56	40*80 Square tube plug	2			
	No.42	50*50 Square tube plug	1			

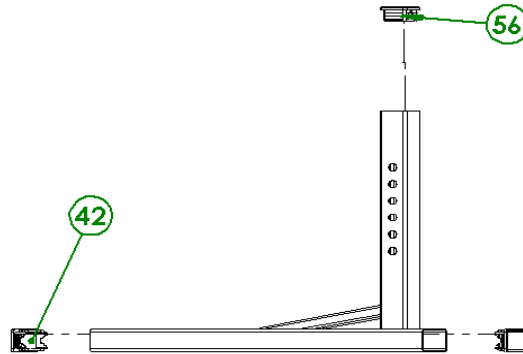

No.6 handle left assembly*1pc

Step	Item No.	Name	Quantity	Item No.	Name	Quantity
	No.61	Φ25*200mm Handle cover	1	W	M8*25 Countersunk Head Screws	1
	No.62	Aluminum end cap	1	V	M5*6 top wire	2
	No.63	Aluminum end cap	1	Z	M8 star nut	1

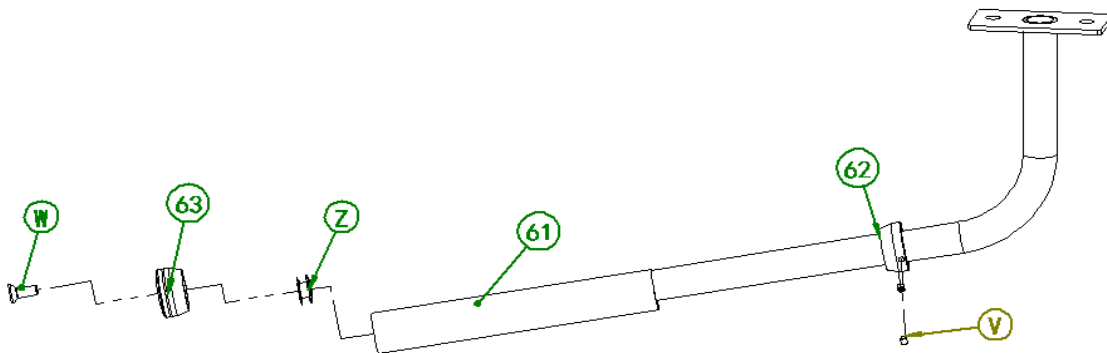

No.5 handle left assembly*1pc

Step	Item No.	Name	Quantity	Item No.	Name	Quantity
	No.61	Φ25*200mm Handle cover	1	W	M8*25 Countersunk	1
	No.62	Aluminum end cap	1	V	M5*6 top wire	2
	No.63	Aluminum end cap	1	Z	M8 star nut	1

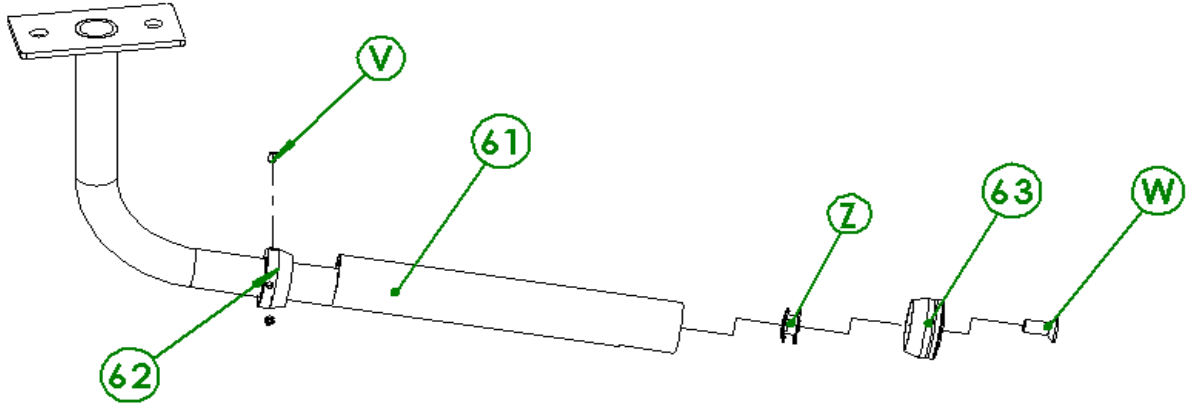

No.14 Counterweight assembly*1pc

Step	Item No.	Name	Quantity	Item No.	Name	Quantity
	No.64	Counterweight guide bush	2			
		counterweight head piece	1			

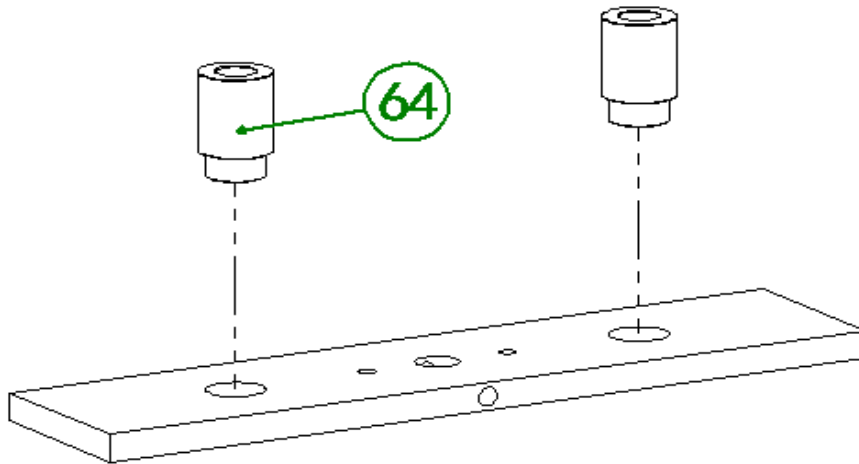

Assembly steps

Step	Item No.	Name	Quantity	Item No.	Name	Quantity
	L1	M5*8 Cross Flat Head Screws	12	No.34	small mount	4
	No.16	Cover	1	P	M8*20 Flat head screws	4
	No.17	Label board	2			

