

OWNER'S MANUAL

KNEELING LEG CURL

PL-3402

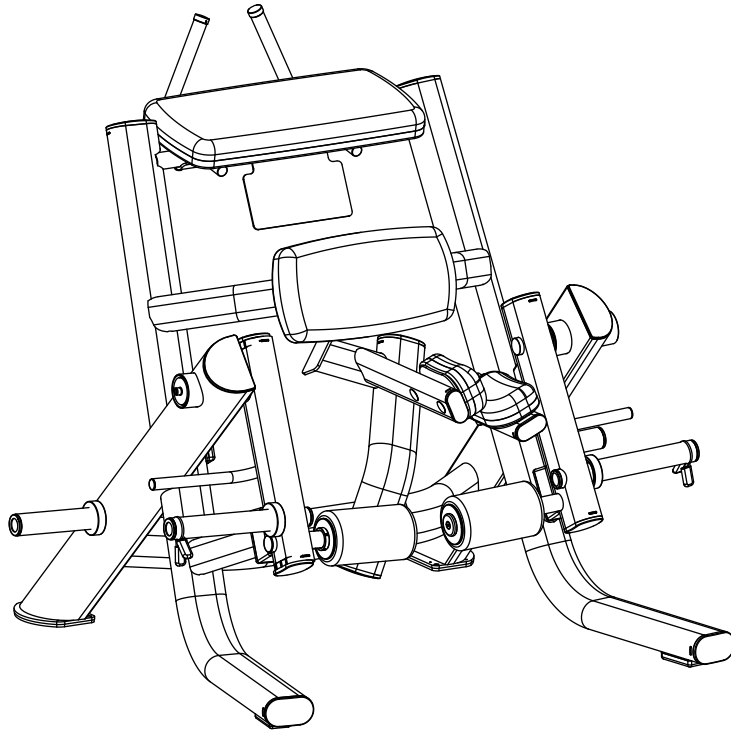

CAUTION: Read all precautions and instructions before using this equipment. Save this manual for future reference.

CONTENTS

02 General warnings and maintenance advice

03-06 Assembly Instructions

Explained as a series of steps, with each step containing:

- Pictures, descriptions and quantities of the parts required
- Notes
- Diagram showing how the parts fit together

07 Part List

Assembly Instructions

Before Your Begin

This exercise equipment is built for optimum safety. Be sure to read the entire manual before you assemble or operate your equipment. Please note the following safety precautions:

1. Keep children and pets away from the equipment at all times. Do not leave children unattended in the same room with the equipment.
2. Only one person at a time should use the equipment.
3. If the user experiences dizziness, nausea, chest pain, or any other abnormal symptoms STOP the workout at once. CONSULT A PHYSICIAN IMMEDIATELY.
4. Position the equipment on a clear, level surface. DO NOT use the equipment near water or outdoors.
5. Keep hands away from all moving parts.
6. Always wear appropriate workout clothing when exercising. DO NOT wear robes or other clothing that could become caught in the equipment.
7. Use the equipment only for its intended use as described in this manual. DO NOT use attachments not recommended by the manufacturer.
8. Before using the equipment, always do stretching exercises to properly warm up.
9. Never operate the equipment if the equipment is not functioning properly.

STEP 1

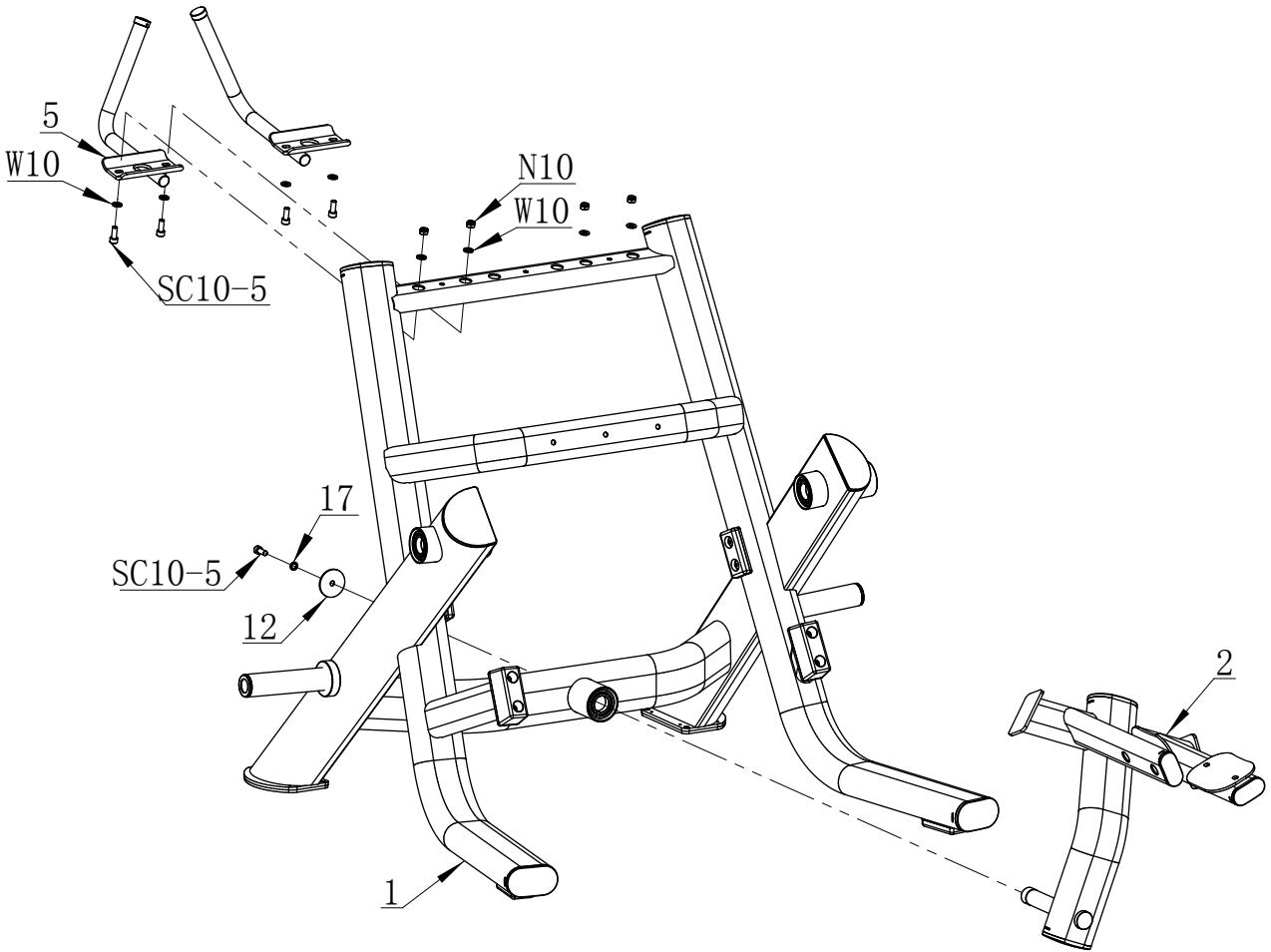

50% 

STEP 2

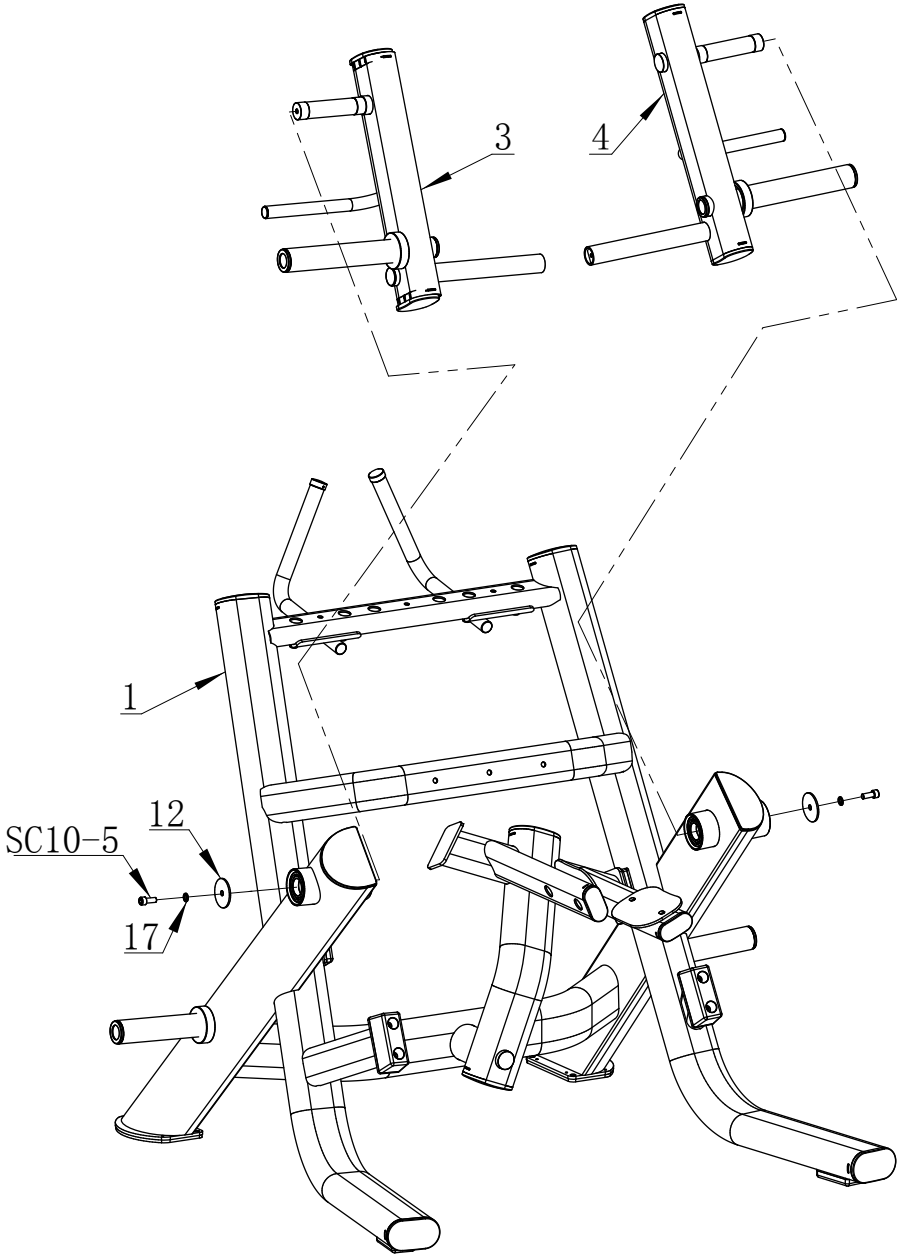

50% 

STEP 3

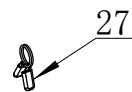
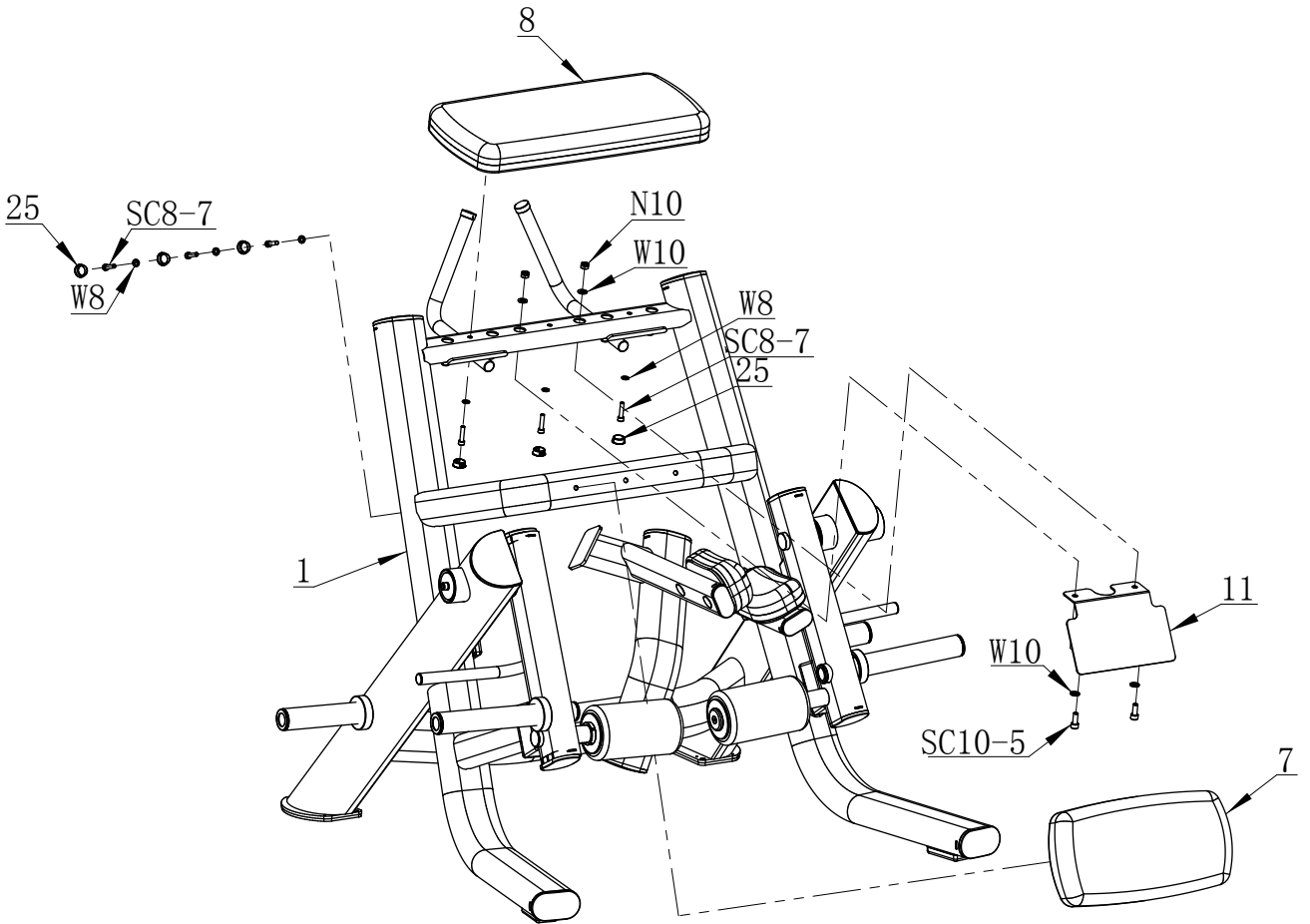
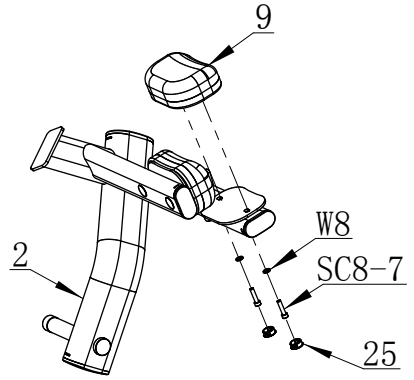
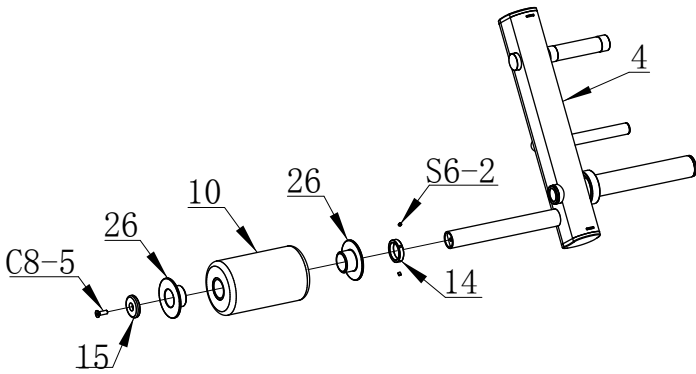

PREASSEMBLED STEP

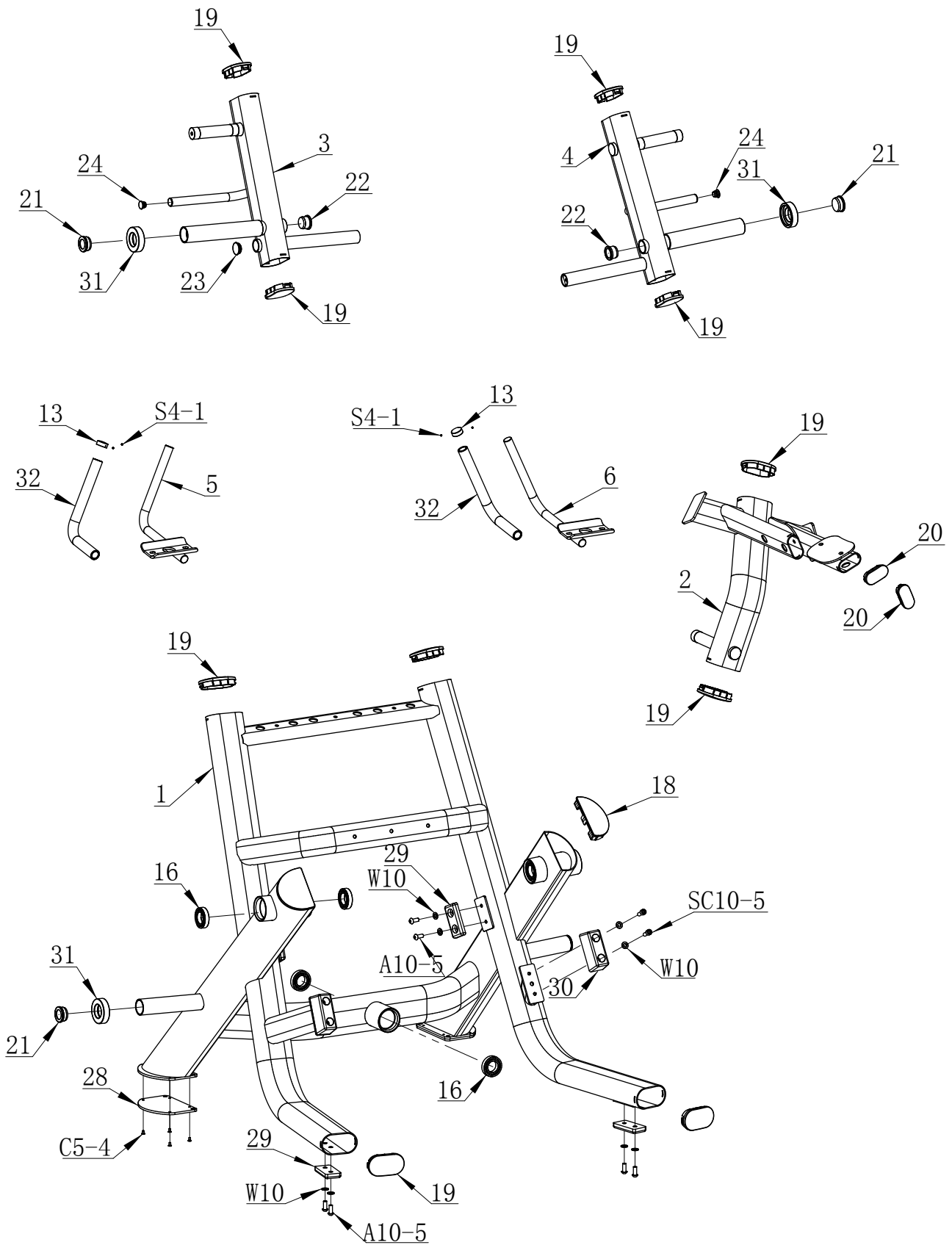

PARTS LIST

PART #	DESCRIPTION	QTY
1	Main Frame	1
2	Support Frame	1
3	Swing Frame 1	1
4	Swing Frame 2	1
5	Handle 1	1
6	Handle 2	1
7	Seat Pad	1
8	Back Pad	1
9	Elbow Pad	2
10	Foam Roller	2
11	Poster Board	1
12	D60 Washer	3
13	D33 Cap	2
14	Foam Ring	2
15	Foam Cap	2
16	Bearing 6700	6
17	Spring Washer	3
18	D Cap	2
19	PT Cap (65X114)	10
20	PT Cap (40X80)	2
21	D48 Cap	4
22	D42 Cap	2
23	D38X3.0 Cap	2
24	D25X3.0 Cap	2
25	Hole Cap	10
26	Foam Bushing	4
27	D48 Spring card	2
28	Rubber Foot	2
29	Limit Pad 1	4
30	Limit Pad 2	2
31	D42 Rubber Block	4
32	Grip	2
S4-1	Socket Set Screw M4X3	4
S6-2	Socket Set Screw M6X6	4
C5-4	Cross Pan Head Screw M5X10	8
C8-5	Cross Pan Head Screw M8X25	2
A10-5	Allen Bolt M10X25	8
SC8-7	Socket Cap Screw M8X35	10
SC10-5	Socket Cap Screw M10X25	13
W8	Washer Φ 8	10
W10	Washer Φ 10	24
N10	Nut M10	6