

# OWNER'S MANUAL

## CHEST PRESS

PL-3303

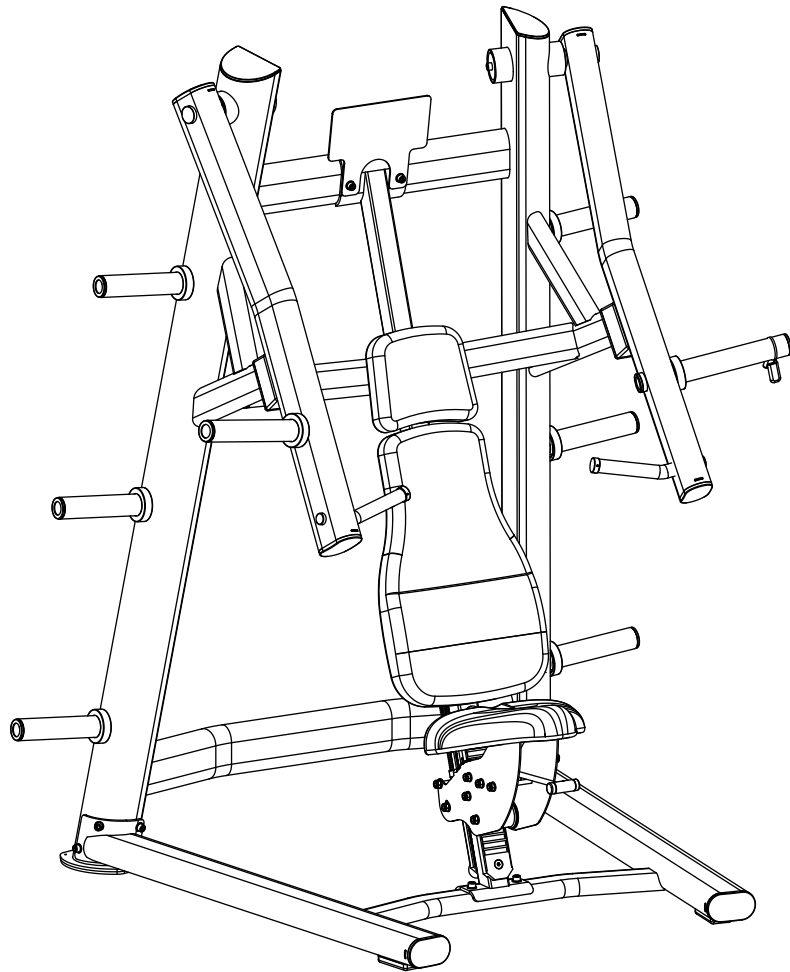

**CAUTION:** Read all precautions and instructions before using this equipment. Save this manual for future reference.

# CONTENTS

02 General warnings and maintenance advice

03-06 Assembly Instructions

Explained as a series of steps, with each step containing:

- Pictures, descriptions and quantities of the parts required
- Notes
- Diagram showing how the parts fit together

07 Part List

# ***Assembly Instructions***

## **Before Your Begin**

This exercise equipment is built for optimum safety. Be sure to read the entire manual before you assemble or operate your equipment. Please note the following safety precautions:

1. Keep children and pets away from the equipment at all times. Do not leave children unattended in the same room with the equipment.
2. Only one person at a time should use the equipment.
3. If the user experiences dizziness, nausea, chest pain, or any other abnormal symptoms STOP the workout at once. CONSULT A PHYSICIAN IMMEDIATELY.
4. Position the equipment on a clear, level surface. DO NOT use the equipment near water or outdoors.
5. Keep hands away from all moving parts.
6. Always wear appropriate workout clothing when exercising. DO NOT wear robes or other clothing that could become caught in the equipment.
7. Use the equipment only for its intended use as described in this manual. DO NOT use attachments not recommended by the manufacturer.
8. Before using the equipment, always do stretching exercises to properly warm up.
9. Never operate the equipment if the equipment is not functioning properly.

# STEP 1

## NOTE:

- In this Step, all the washers and nuts which are not marked are W10 and N10.

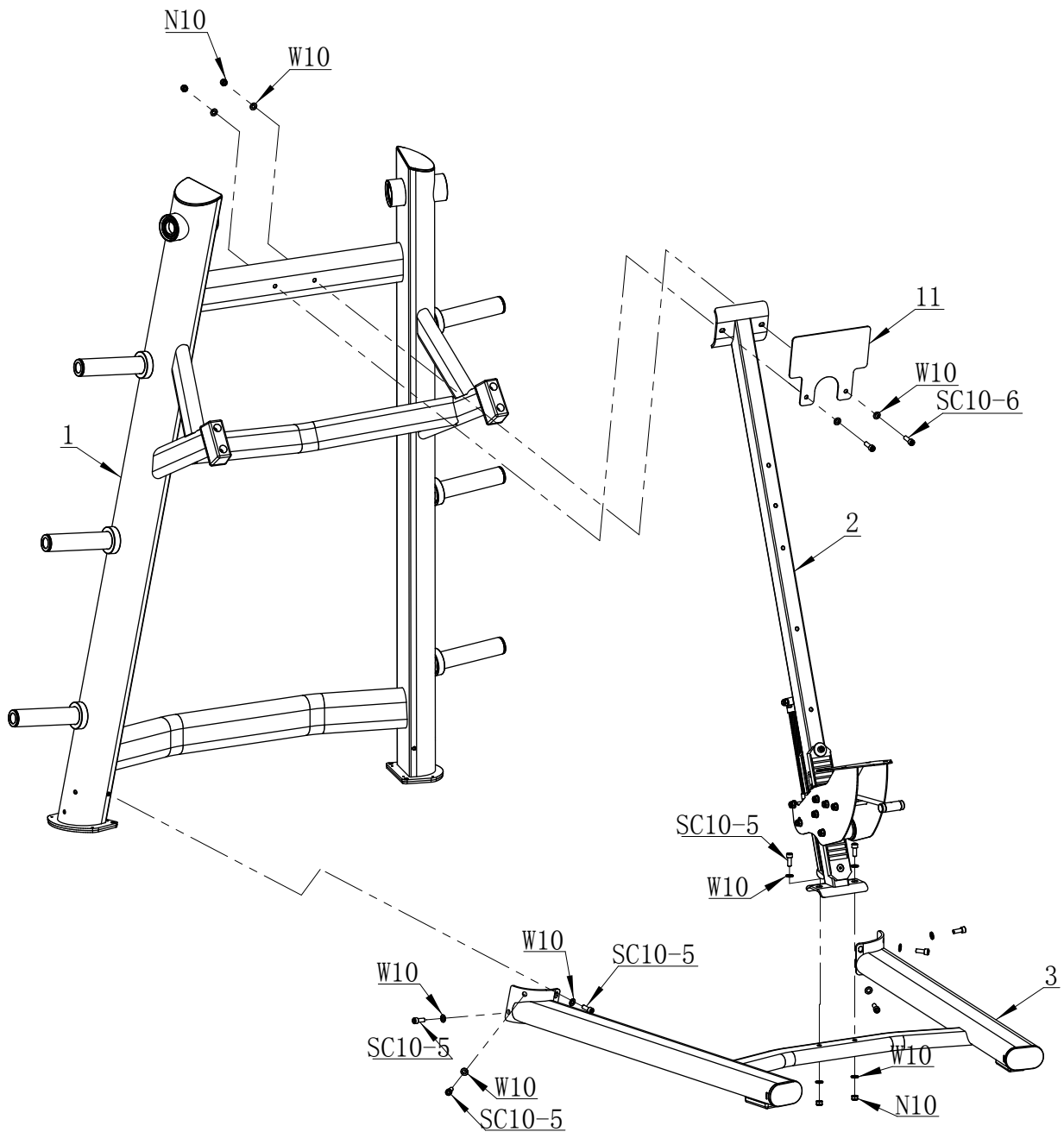

50%



# STEP 2

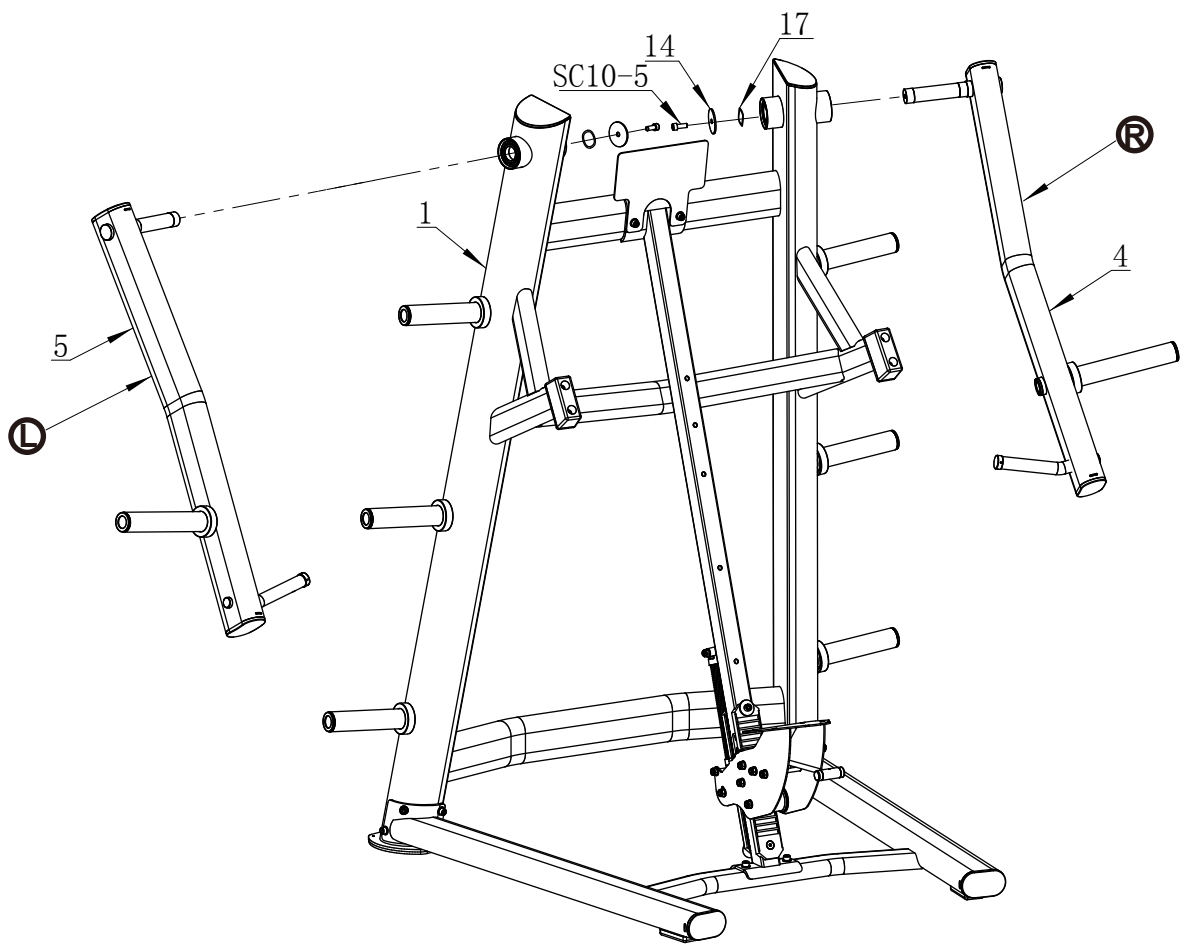

50% 

# STEP 3

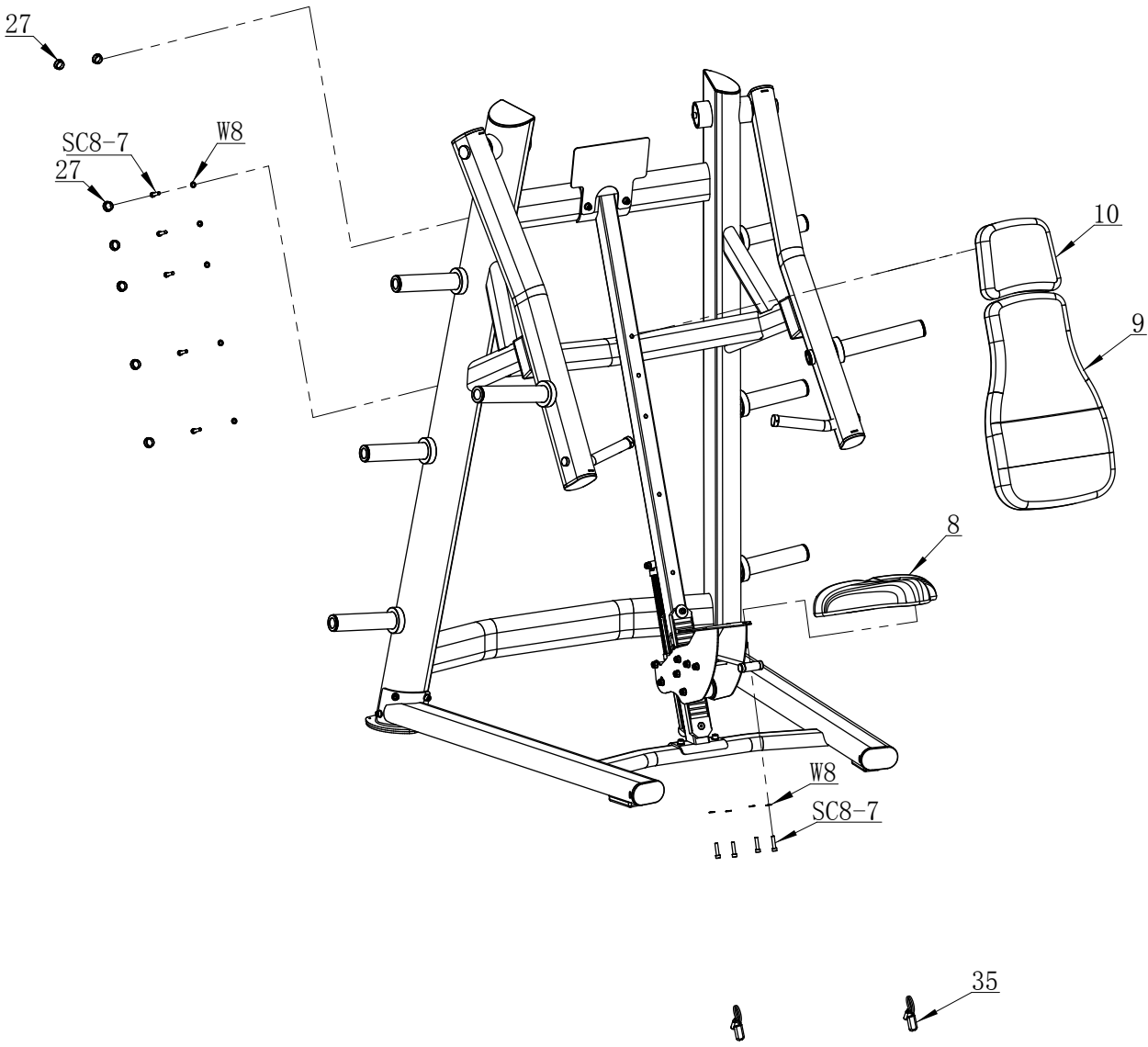

# PREASSEMBLED STEP

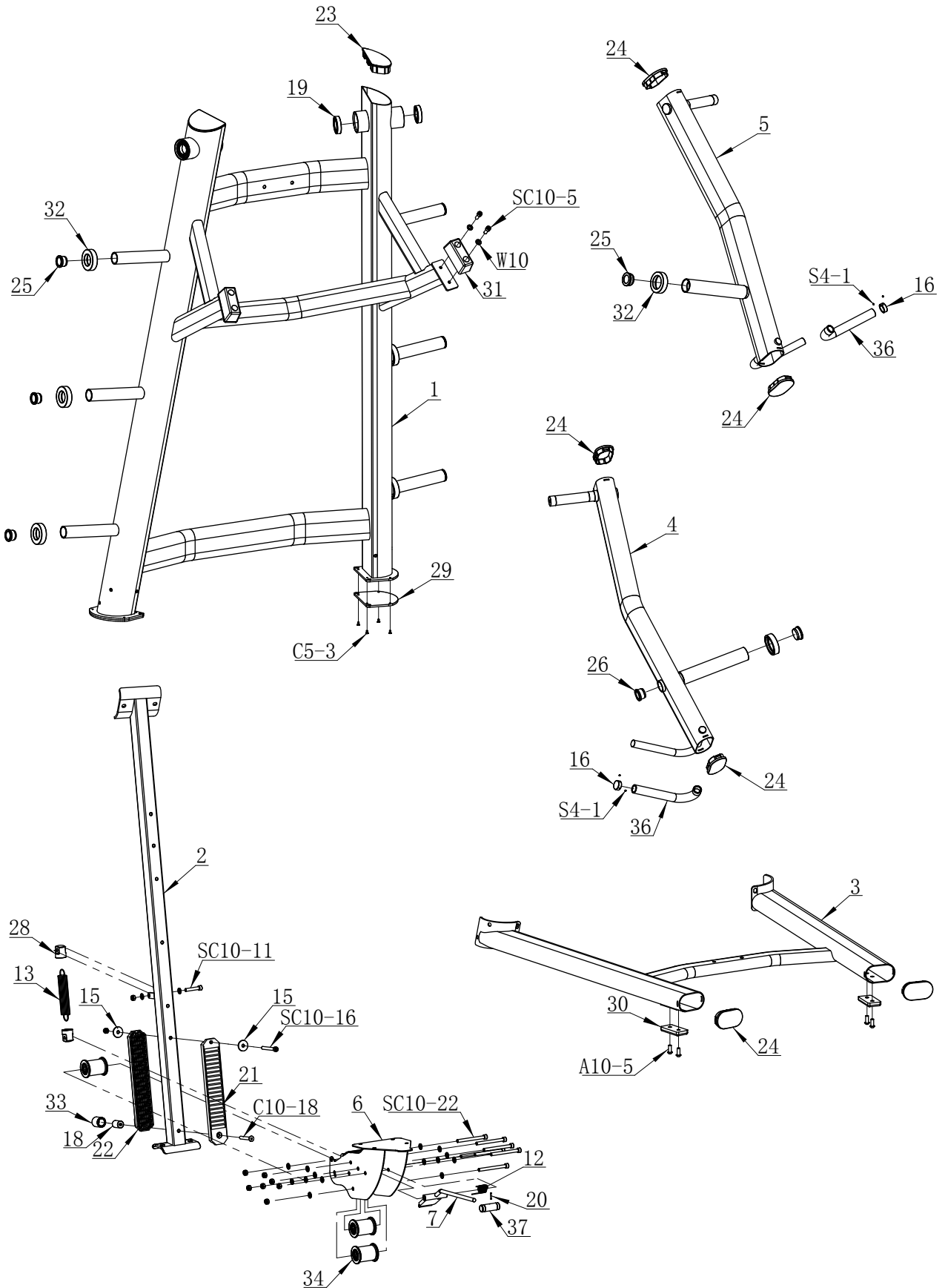

## PARTS LIST

PART #	DESCRIPTION	QTY
1	Support Frame 1	1
2	Support Frame 2	1
3	Base Frame	1
4	Handle 1	1
5	Handle 2	1
6	Seat Support Frame	1
7	Seat ADJ Handle	1
8	Seat Pad	1
9	Back Pad	1
10	Head Pad	1
11	Poster Board	1
12	Spring 1	1
13	Spring 2	1
14	D60 Washer	2
15	D38 Washer	2
16	D33 Cap	2
17	Wave Washer	2
18	Limit Round Iron	1
19	Bearing 6007	4
20	Spring Pin	1
21	ADJ Plate 1	1
22	ADJ Plate 2	1
23	D Cap	2
24	PT Cap	6
25	D48 Cap	8
26	D42 Cap	2
27	D25 Cap	7
28	Spring Cover	2
29	Foot Cover	2
30	Limit Pad 1	2
31	Limit Pad 2	2
32	D48 Rubber Block	8
33	Crash pad	1
34	Wheel	3
35	D48 Spring card	2
36	Grip	2
37	ADJ Handle	1
38	Lable	2
S4-1	Socket Set Screw M4X3	4
C5-4	Cross Pan Head Screw M5X10	8
C10-16	Cross Pan Head Screw M10X80	1
A10-5	Allen Bolt M10X25	4
SC8-7	Socket Cap Screw M8X35	9
SC10-5	Socket Cap Screw M10X25	14
SC10-6	Socket Cap Screw M10X30	2
SC10-11	Socket Cap Screw M10X55	1
SC10-18	Socket Cap Screw M10X90	1
SC10-22	Socket Cap Screw M10X110	7
W8	Washer $\Phi$ 8	9
W10	Washer $\Phi$ 10	34
N10	Nut M10	13