

Model: RCAF-LMF-1

INSTALLATION AND OPERATING INSTRUCTIONS

SINGLE-FUNCTION WIRELESS REMOTE CONTROL SYSTEM FOR OPERATING VALVES WITH ON/OFF LATCHING SOLENOIDS

**IF YOU CANNOT READ OR UNDERSTAND THESE INSTALLATION INSTRUCTIONS DO NOT
ATTEMPT TO INSTALL OR OPERATE**

INTRODUCTION

This remote control system was developed to provide a safe, reliable, and user-friendly remote control system for the AF-LMF valve kit. The system is operated manually from the transmitter. The system operates on radio frequencies (RF) within a 20-foot range using non-directional signals. The system operates on one of 255 security codes that are programmed into the transmitter at the factory; the remote receiver must learn the transmitter code prior to initial use.

Review THERMO SAFETY SECTION under RECEIVER section. This high temperature safety feature shuts down the appliance when a potentially unsafe condition exists.

TRANSMITTER

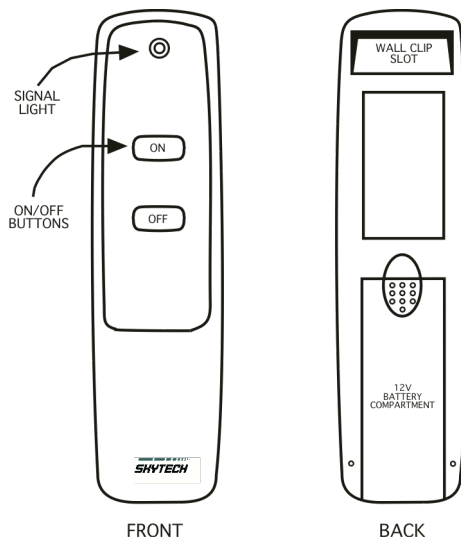

This remote control SYSTEM offers the user a battery-operated remote control to power an ON/OFF latching solenoid such as the one used with the AF-LMF valve kit.

The circuit uses the battery power from the receiver to operate a latching solenoid. The circuit has reversing polarity software that reverses the positive (+) and negative (-) output of the receiver's battery power to drive solenoid (ON/OFF FLAME) or open/close. The SYSTEM is controlled by the remote transmitter.

The transmitter operates on a 12V battery made specifically for remote controls and electronic lighters. Before using the transmitter install the 12-volt (A-23) battery in the battery compartment.

It is recommended that ALKALINE batteries always be used for longer battery life and maximum operational performance.

The transmitter has ON and OFF functions that are activated by pressing either button on the face of the transmitter. When a button on the transmitter is pressed, a signal light on the transmitter illuminates to verify that a signal is being sent. Upon initial use, there may be a delay of three seconds before the remote receiver will respond to the transmitter. This is part of the system's design. If the signal light does not illuminate, check the position of the transmitter's battery.

INSTALLING THE ON/OFF SOLENOID

NOTE: The AF-LMF valve kit comes with a brass cap fitting that must be removed before the ON/OFF solenoid can be installed. Under this brass cap fitting there is a unique safety seal that prevents gas leakage after the brass cap fitting has been removed. This allows the brass cap fitting to be removed and the ON/OFF solenoid to be installed without shutting off the main gas valve that supplies gas to the AF-LMF valve kit.

1. Remove the (2) screws from the front metal faceplate then remove the faceplate on the AF-LMF valve kit and set aside.
2. Using a screwdriver remove the brass cap fitting. Note Figure 1 (Retain the brass cap fitting so if the solenoid is removed the brass cap fitting can be reinstalled)

3. Install the ON/OFF solenoid into the threaded hole on the AF-LMF that the brass cap fitting was removed from and screw into place and do not over tighten. NOTE: Figure 2
4. Replace the AF-LMF front faceplate and reinstall the (2) screws and tighten.
5. Make sure to locate the RED & BLACK wires so they come out the back of the AF-LMF to connect to the receiver.

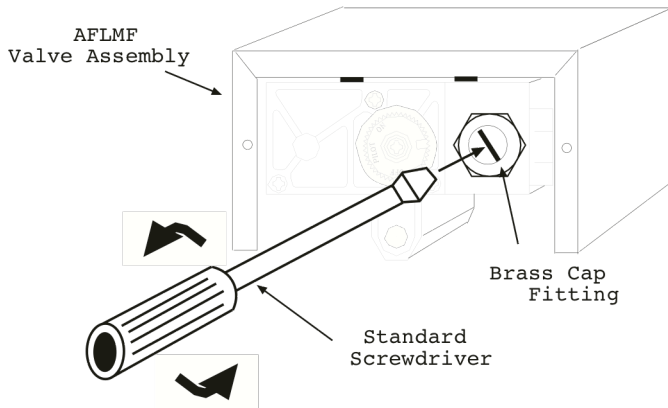

Figure #1

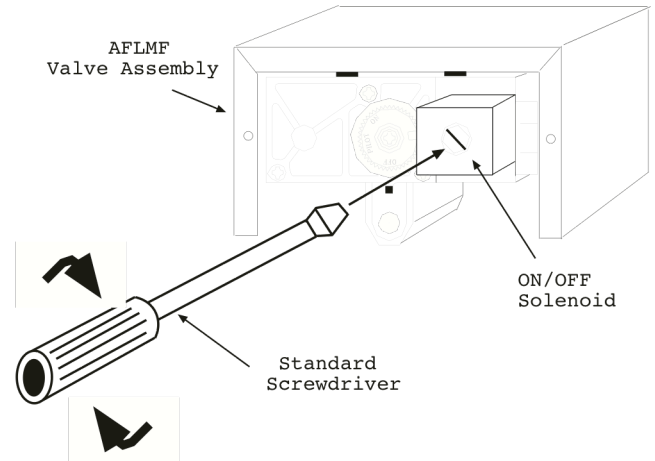

Figure #2

WIRING INSTRUCTIONS

CONNECTING THE RECEIVER TO THE AF-LMF VALVE KIT WITH THE LATCHING SOLENOID

1. Connect the BLACK 18 gauge stranded wire with the 1/4" female terminal from the receiver to the BLACK wire with the 1/4" male terminals from the valve solenoid.
2. Connect the RED 18 gauge stranded wire with the 1/4" female terminal from the receiver to the RED wire with the 1/4" male terminals from the valve solenoid.
3. After receiver wires are connected to the valve solenoid wire make sure the receiver shield is located over the receiver and then locate the receiver in an area that will not exceed the 130° F. This location will always be away from the AF-LMF towards the front of the firebox.

IMPORTANT NOTE: Operation of these controls is dependent on which wire is attached to which terminal. If operation of control does not correspond to operating buttons on transmitter, reverse wire installation at the receiver or at the control.

NOTE: Up to 6.3 VDC of power is provided at the receiver terminal.

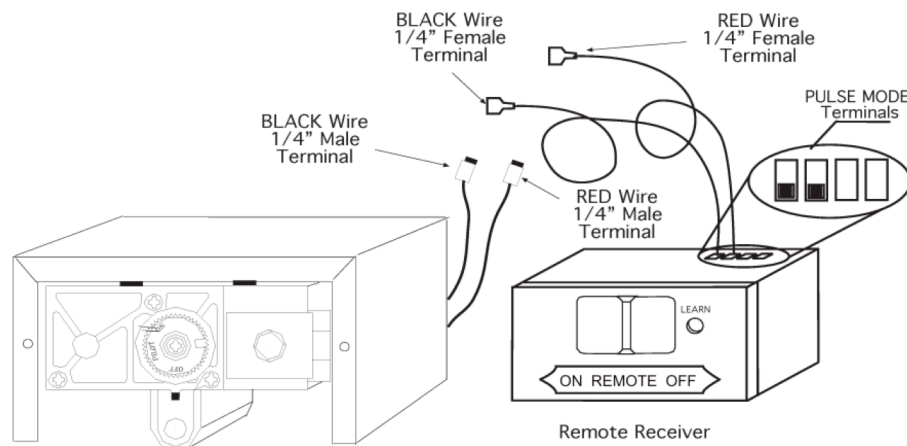

POWER SETTING – RCAF-LMF

The RECEIVER comes from the factory programmed to provide pulse DC voltage (5.5) VDC to 6.3 VDC) to a latching solenoid.

REMOTE RECEIVER

IMPORTANT

THE REMOTE RECEIVER SHOULD BE POSITIONED WHERE AMBIENT TEMPERATURES DO NOT EXCEED 130° F.

The remote receiver (right) operates on (4) 1.5V AA-size batteries. It is recommended that ALKALINE batteries be used for longer battery life and maximum microprocessor performance. **IMPORTANT:** New or fully charged batteries are essential to proper operation of the remote receiver as a latching solenoid power consumption is substantially higher than standard remote control systems.

NOTE: The remote receiver will only respond to the transmitter when the 2-position slide button on the remote receiver is in the REMOTE position. The remote receiver houses the microprocessor that responds to commands from the transmitter to control system operation.

FUNCTIONS:

- With the slide switch in the ON position (toward the LEARN button), the system will remain on until the slide switch is placed in the OFF or REMOTE position.
- With the slide switch in the REMOTE position (centered), the system will only operate if the remote receiver receives commands **from the transmitter**.
- With the slide switch in the OFF position (away from the LEARN button), the system is OFF.
- **It is suggested that the slide switch be placed in the OFF position if you will be away from your home for an extended period of time. If the remote receiver is mounted out of children's reach, placing the slide switch in the OFF position also functions as a safety "lock-out" by both turning the system off and rendering the remote receiver inoperative.**

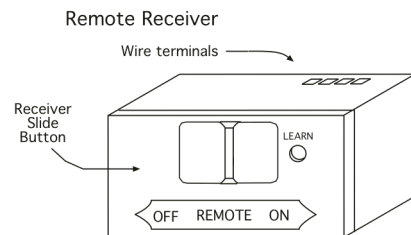
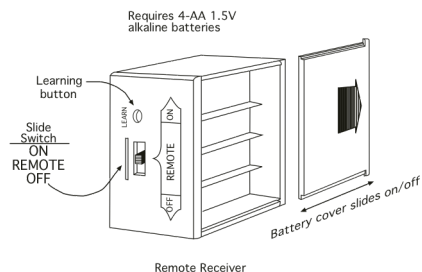

INSTALLATION INSTRUCTIONS

WARNING

DO NOT CONNECT REMOTE RECEIVER DIRECTLY TO 110-120VAC POWER. THIS WILL BURN OUT THE RECEIVER. FOLLOW INSTRUCTIONS FROM MANUFACTURER OF GAS VALVE FOR CORRECT WIRING PROCEDURES. IMPROPER INSTALLATION OF ELECTRIC COMPONENTS CAN CAUSE DAMAGE TO GAS VALVE AND REMOTE RECEIVER.

INSTALLATION

The remote receiver can be mounted on or near the fireplace hearth. **PROTECTION FROM EXTREME HEAT IS VERY IMPORTANT.** Like any piece of electronic equipment, the remote receiver should be kept away from temperatures exceeding 130° F inside the receiver case. Battery life is also significantly shortened if batteries are exposed to high temperatures.

Make sure the remote receiver switch is in the OFF position. For best results it is recommended that 18 gauge stranded wires should be used to make connections and no longer than 20-feet.

GENERAL INFORMATION

LEARNING TRANSMITTER TO RECEIVER

Each transmitter uses a unique security code. It will be necessary to press the LEARN button on the receiver to accept the transmitter security code upon initial use, if batteries are replaced, or if a replacement transmitter is purchased from your dealer or the factory. In order for the receiver to accept the transmitter security code, be sure the slide button on the receiver is in the REMOTE position; the receiver will **not** LEARN if the slide switch is in the ON or OFF position. The LEARN button is located on the front face of the receiver; inside the small hole labeled LEARN. Using a small screwdriver or end of a paperclip gently press and release the black LEARN button inside the hole. When you release the LEARN button the receiver will emit an audible "beep". After the receiver emits the beep press the transmitter ANY button and release. The receiver will emit several beeps indicating that the transmitter's code has been accepted into the receiver.

The microprocessor that controls the security code matching procedure is controlled by a timing function. If you are unsuccessful in matching the security code on the first attempt, wait 1 - 2 minutes before trying again--this delay allows the microprocessor to reset its timer circuitry--and try up to two or three more times.

TRANSMITTER WALL CLIP

The transmitter can be hung on a wall using the clip provided. If the clip is installed on a solid wood wall, drill 1/8" pilot holes and install with the screws provided. If it is installed on a plaster/wallboard wall, first drill two 1/4" holes into the wall. Then use a hammer to tap in the two plastic wall anchors flush with the wall; then install the screws provided.

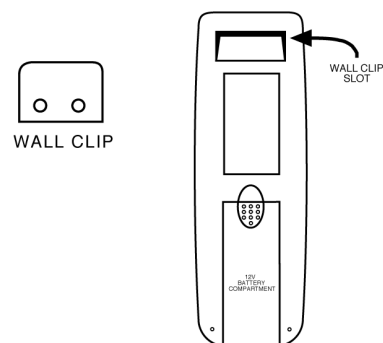

OPERATION

4. This remote control will operate the gas valves latching solenoid to open the gas flow to full ON.
5. When the ON button is depressed the transmitter sends a RF signal to the receiver. The receiver then sends a pulse of 6-volts of power to the solenoid. The solenoid then opens the gas flow to the burner then to full ON.
6. When the OFF button is depressed the transmitter sends a RF signal to the receiver. The receiver then sends a pulse of 6-volts of power to the solenoid. The solenoid then closes the gas flow to the burner then to full OFF.
7. The remote control will only work with the hand held transmitter. The receiver slide switch is only for positive OFF or REMOTE operation.

NOTE: Extensive use of the Latching Solenoid (ON/OFF) will significantly reduce the receiver's battery life.

BATTERY LIFE

Life expectancy of the alkaline batteries in the RCAF-LMF can be up to 12 months depending on use of the solenoid function. Replace all batteries annually. When the transmitter no longer operates the remote receiver from a distance it did previously (i.e., the transmitter's range has decreased) or the remote receiver does not function at all, the batteries should be checked. It is important that the remote receiver batteries are fully charged, providing combined output voltage of at least 5.0 volts. The transmitter should operate with as little as 9.0 volts battery power. **NOTE:** Extensive use of the Solenoid will reduce the receiver's battery life significantly.

TROUBLE SHOOTING

If you encounter problems with your fireplace system, the problem may be with the fireplace itself or it could be with the RCAF-LMF remote system. Review the fireplace manufacturer's operation manual to make sure all connections are properly made. Then check the operation of the remote in the following manner:

1. Make sure the batteries are correctly installed in the RECEIVER. One reversed battery will keep receiver from operating properly.
2. Check battery in TRANSMITTER to ensure contacts are touching (+) and (-) ends of battery. Bend metal contacts in for tighter fit.
3. Be sure RECEIVER and TRANSMITTER is within 20 to 25-foot operating range.
4. Keep RECEIVER from temperatures exceeding 120° F. Battery life shortened when ambient temperatures are above 115° F.
5. If RECEIVER is installed in tightly enclosed metal surround, the operating distance will be shortened.

6. Clear Codes: Memory in the receiver might be full if the learn button is pressed too many times. If this happens it will not allow any more codes to be learned and no audible beep will be heard. To clear memory, place the receiver slide switch into the REMOTE position. Press the learn button and release after 10 seconds. You should hear three (3) long audible beeps indicating all codes have cleared. You can now "learn" the transmitter to the receiver as described in the General Information Section.

SPECIFICATIONS

BATTERIES: Transmitter 12V - (A23)

Remote Receiver 6V - 4 ea. AA 1.5 Alkaline

FCC ID No.'s: transmitter - K9L1002TX; receiver - K9L300IRX

Operating Frequency: 303.8 MHZ

Canadian ISC ID No.'s: transmitter - 2439 102 728; receiver - 2439 102 728A

FCC REQUIREMENTS

NOTE: THE MANUFACTURER IS NOT RESPONSIBLE FOR ANY RADIO OR TV INTERFERENCE CAUSED BY UNAUTHORIZED MODIFICATIONS TO THIS EQUIPMENT. SUCH MODIFICATIONS COULD VOID THE USER'S AUTHORITY TO OPERATE THE EQUIPMENT.