

heatilator®
The first name in fireplaces



Rave Series

Direct Vent Gas Fireplace



modern linear style,
proven value

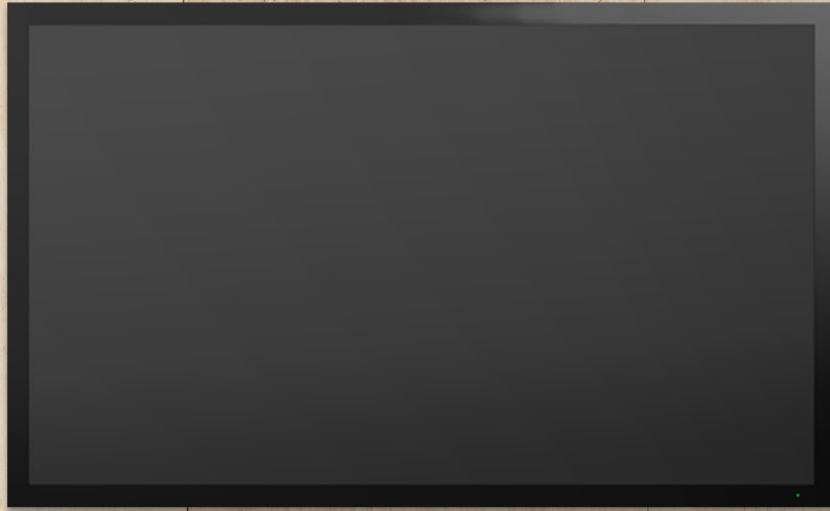

The Rave adds a modern linear style and proven value to any home or office! Contemporary design elements are highlighted by a long, mesmerizing ribbon of flame rising through attractive modern media. Explore unique placements and create a custom look with a choice of finishing options. With unsurpassed dependability and exceptional value, the Rave gas fireplace series is another way Heatilator has been keeping America warm since 1927.



Features

- 32", 36" or 42" wide viewing area
- Moderate heat output—up to 25,250 BTUs
- Multiple interior finishing options
- Convex or flat front options
- Enhanced safety with the IntelliFire Touch® ignition system
- Select from the IntelliFire® app, touchscreen remote or wireless wall switch for the solution that fits your life
- Optional heat management solution kits are available that redirect heat to another area of the home, including Passive Heat™ and Heat-Zone

Options

Fronts



Clean face trim available in black or bronze (bronze available for 42" only)



Illusion available in black only



Illusion top view

Fan



Moves heat into the room for added comfort

Interiors

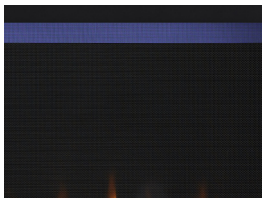

LED accent lighting



Fade-resistant reflective black glass interior panels



Multicolored ceramic fiber stones



Crystal glass



Black glass

Controls

IntelliFire App

All the features of a remote control with an app installed on your smart device. Monitor your fire from anywhere or even control it with the sound of your voice. IntelliFire is compatible with voice assistants Amazon Alexa and Google Assistant.



Touchscreen Remote

Features: on/off, flame height adjustment, fan speed, lights adjustment, thermostat mode, room temperature readout, child lock, timer mode, battery backup, cold climate mode, power vent, wall docking station (fan, lights and power vent are dependent on your fireplace).



Wireless Wall Switch

Features: on/off, battery strength indicator, cold climate mode



LED Accent Lighting Wall Switch

LED accent lighting is set to desired color when installed. An optional LED light switch allows user to change the color at any time.



Technology

IntelliFire Touch Ignition System

IntelliFire Touch is our most advanced intermittent-pilot ignition (IPI) system, making operating your appliance simple, smart and safe. Select from the IntelliFire app, touchscreen remote or wireless wall switch for the solution that fits your life.

Direct Vent Technology

Direct Vent fireplaces remove 100% of combustion exhaust and odors outside of the home. These sealed fireplaces provide optimal heat, conserve energy and ensure clean, safe indoor air quality. To learn more, visit heatilator.com.

Heat Management Solutions

Bring the warmth from your fireplace to the rest of your home, up to 20 feet away. Heat management solutions can redirect up to 50% of the heat to another area, and reduce wall temperatures above the fireplace. Choose between:

- **Passive Heat™ kit** to allow heat to naturally rise and disperse at ceiling height without the use of a fan
- **Heat-Zone® kit** to transfer heat where you want it
- **Heat-Out® kit** to redirect heat from the fireplace outside the home

Specifications

| MODEL | FRONT WIDTH (A) | | HEIGHT (B) | | DEPTH (C) | | BACK WIDTH (D) | | GLASS SIZE (E X F) | BTU/HR INPUT |
|----------|-----------------|---------------|--------------------|------------------|------------------|------------------|------------------|---------------|----------------------------------|----------------------------|
| | ACTUAL | FRAMING | ACTUAL | FRAMING | ACTUAL | FRAMING | ACTUAL | FRAMING | | |
| Rave 32" | 36" (914) | 37" (940) | 38-1/16" (967) | 36-1/2" (927) | 17-3/4" (451) | 17-3/4" (451) | 25-3/4" (654) | 37" (940) | 27-1/4" x 15-1/4" (692 x 387) | 19,000 (NG) 16,500 (LP) |
| Rave 36" | 41" (10419) | 42" (1067) | 33-11/16" (856) | 32-3/4" (832) | 17-3/4" (451) | 17-3/4" (451) | 30-3/4" (781) | 42" (1067) | 32-1/4" x 15-1/4" (819 x 387) | 20,500 (NG) 19,000 (LP) |
| Rave 42" | 48" (1219) | 49" (1245) | 33-11/16" (856) | 32-3/4" (832) | 17-3/4" (451) | 17-3/4" (451) | 37-3/4" (959) | 49" (1016) | 39" x 15-1/4" (991 x 387) | 25,250 (NG) 23,500 (LP) |

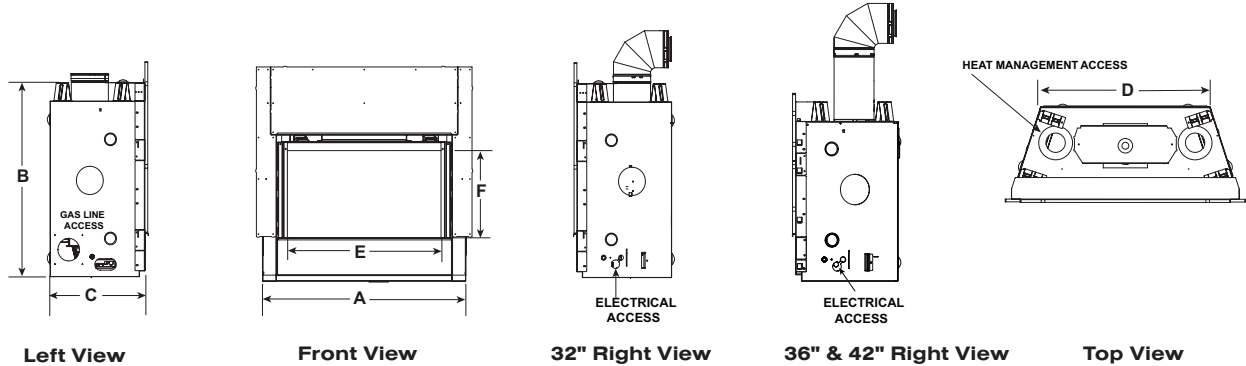

Framing Dimensions

| MODEL | A | B | C | D | E | F | G | H | I | J |
|----------|-----------------|------------------|------------------|---------------|--------------|-----------|-----------|--------------|--------------|--------------|
| Rave 32" | 8-5/8" (219) | 36-1/2" (927) | 17-3/4" (451) | 37" (940) | 31" (787) | 0" (0) | 0" (0) | 1/2" (13) | 1/2" (13) | 36" (914) |
| Rave 36" | 8-5/8" (219) | 32-3/4" (832) | 17-3/4" (451) | 42" (1067) | 31" (787) | 0" (0) | 0" (0) | 1/2" (13) | 1/2" (13) | 36" (914) |
| Rave 42" | 8-5/8" (219) | 32-3/4" (832) | 17-3/4" (451) | 49" (1245) | 31" (787) | 0" (0) | 0" (0) | 1/2" (13) | 1/2" (13) | 36" (914) |

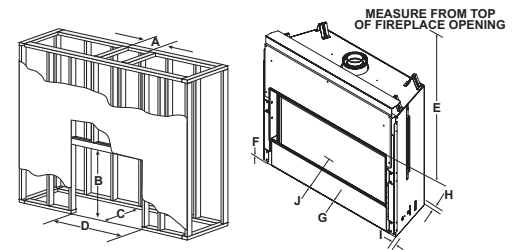

Dimensions are in inches and millimeters. Product information is not complete and is subject to change without notice. Product installation must adhere strictly to instructions shipped with product. We recommend measuring individual units at installation. NOTE: Combustible material should not cover the face. Refer to installation manual for detailed specifications on installing this product. Hearth & Home Technologies® reserves the right to update units periodically. Actual product appearance, including flame, may differ from product images.

Efficiency Ratings

EnerGuide (CSA P.4.1-15) - Used in Canada and some U.S. states to measure annual fireplace efficiency.

| RAVE32-IFT-B | RAVE36-IFT-B | RAVE42-IFT-B |
|--------------|--------------|--------------|
| 51.1% (NG) | 63.0% (NG) | 63.8% (NG) |

Exceptional Value + Dependability

Why do contractors, architects and homebuyers trust Heatilator? Because we mix value with dependability. Established in 1927, Heatilator has built a long standing reputation for providing quality, dependable hearth products at unbeatable values. Today, Heatilator remains thwe most preferred, recommended and installed fireplace brand among building professionals.

Available from

heatilator
The first name in fireplaces

800-927-6841 | heatilator.com

facebook.com/Heatilator

twitter.com/Heatilator

youtube.com/HeatilatorFireplaces

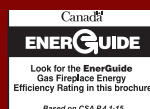

Limited Lifetime Warranty¹

The strongest in the industry, Heatilator provides a limited lifetime warranty on gas-burning products of the most important aspects: firebox and heat exchanger.

The information provided in this literature is for planning purposes only and subject to change. Please consult the installation manual for actual installation. Actual product appearance may differ from product images.

¹ For full warranty details go to heatilator.com.

Google, YouTube and Google Home are trademarks of Google LLC. Amazon, Alexa, and all related logos are trademarks of Amazon.com, Inc. or its affiliates.