

Warning and Instructions for Use

Read the instructions before operating this Auto Darkening Welding Helmet. This helmet is not designed for laser or laser cutting or gas welding. This helmet is designed to protect your eyes and face from sparks, spatter and harmful IR and UV radiation. This helmet will not protect you from explosive devices or corrosive liquids.

Never operate this helmet without the lens cover properly installed. Keep front lens cover and light sensors clean for proper operation.

Replace auto darkening lens if it is cracked, scratched or pitted to avoid serious personal injury.

Use only replacement parts specified in this manual.

Welding with the Auto Helmet

Before using the filter, it is recommended that the following adjustments are made:

Turn the sensitivity dial clockwise to the maximum setting. Depending upon the surrounding light the filter will switch to the dark state or will flicker (if the surrounding light is very low, the filter may not switch to the dark state).

Turn the sensitivity dial anti-clockwise to the minimum setting until the filter switches to the clear state.

The filter is now set to its optimum sensitivity (according to the surrounding light conditions).

The Auto Darkening Welding Helmet will automatically change from a light state (shade No 4) to a dark state (No 9, No 10, No 11, No 12, No 13) when the arc welding starts. The lens automatically returns to a light state when the arc stops.

Infinite shade adjustments can be made between 9 and 13 whilst welding.

Match your welding application to the shade indicated on the shade chart in this manual.

This helmet has been designed for MIG, TIG, SMAW, Plasma Arc and Air carbon arc cutting.

Setting the Delay

The clearing delay can be adjusted manually by turning the delay dial a fast 0.1 second clear (fully anti-clockwise) or a slow 1.0 second clear (fully clockwise).

Recommended Usage

Process	AMPS																			
	15	6	10	15	30	40	60	70	100	125	150	175	200	225	250	300	350	400	450	500
Covered Electrodes	8														9	10	11	12	13	14
MAG	8														9	10	11	12	13	14
TIG	8														9	10	11	12	13	
MIG with Heavy Metals	9														10	11	12	13	14	
MIG with Light Alloys	10														11	12	13	14		
Air-Arc gouging	10														11	12	13	14	15	
Plasma Jet Cutting	9														10	11	12	13		
Microplasma Arc Welding	4	5	6	7	8	9	10	11	12											

NOTE: The term "heavy metals" applies to steel, alloy steels, copper and its alloys, etc.

How to Set The Shade

To allow the filter to switch, both sensors on the front of the filter must not be covered. The filter switches to the dark state when the arc strikes and to the clear state when it stops.

On the Auto Helmet, set the shade by turning the dial on the outside of the helmet. Refer to the chart above for the most suitable shade settings. You can manually change the shade setting during welding by turning the dial clockwise (DARKER)

or anti-clockwise (LIGHTER).

Technical Specifications

Dimensions	110 x 90 x 8 mm
Viewing Area	96 x 42 mm
Lightstate	Shade 4
Darkstate	Variable Shade DIN 9-13
UV / IR Protection	Up to DIN 13
Switching Time	0.0001 seconds
Dark to Light Delay	0.1-0.9 seconds stepless adjustable
Light Sensors	Two
Power Supply	Solar Cells
Operating Temperature	-5°C to 55°C (23°F to 131°F)
Storage Temperature	-30°C to 80°C (-22°F to 176°F)
Casing	Plastic
Warranty	24 months from date of purchase
Conformity	CE 0196 4/9-13 CSS 1/3/1/379

Maintenance

Set function to suitable shade number, according to sort and environment of weld work.

Operating temperature: -5°C to 55°C (23°F to 131°F).

Do not use or open the shade cartridge if damaged by shock, vibration or pressure.

Keep the sensors and solar cell clean and un-obscured. Clean the cartridge using a neutral soap and soft cloth which should be damp and not saturated.

DO NOT USE solvents or abrasive cleaning detergent.

If the cover lens is spattered or covered with dirt, it should be replaced immediately.

Use only the original front cover plate.

Do not use this Auto Darkening Welding Helmet without cover plate fitted, otherwise this may cause a malfunction which will void the warranty.

Replacement of Front Lens Cover

Replacement is needed if the lens becomes broken, cracked or dirty.

With the helmet facing you, remove front lens cover by pulling towards you.

Warning: DO NOT operate the helmet without the front lens cover as this will void the warranty.

Changing the Auto Darkening Lens

Using pliers, pull of the external adjuster dial. Unscrew the retaining nut. Pull the potentiometer through. Unscrew and remove the fixing frame. Remove cartridge.

Checklist

Check the quality of your Auto Darkening Welding Helmet carefully and make sure that all the relevant parts are supplied. If any parts are missing, please contact your distributor.

Complete welding helmet set:

Shade Cartridge
Front Cover Plate and Inside Cover Plate
Headband including Sweatband

Limited Warranty

Auto Darkening Welding Helmets are covered by a 24 month parts only warranty.

This warranty covers product failure due to defective parts or workmanship and excludes failure due to normal 'wear and tear' or incorrect operation. See pages 1-3 of this instruction manual for correct operation and maintenance of this product.

Note: Spatter damage invalidates the warranty.

Parts Diagram

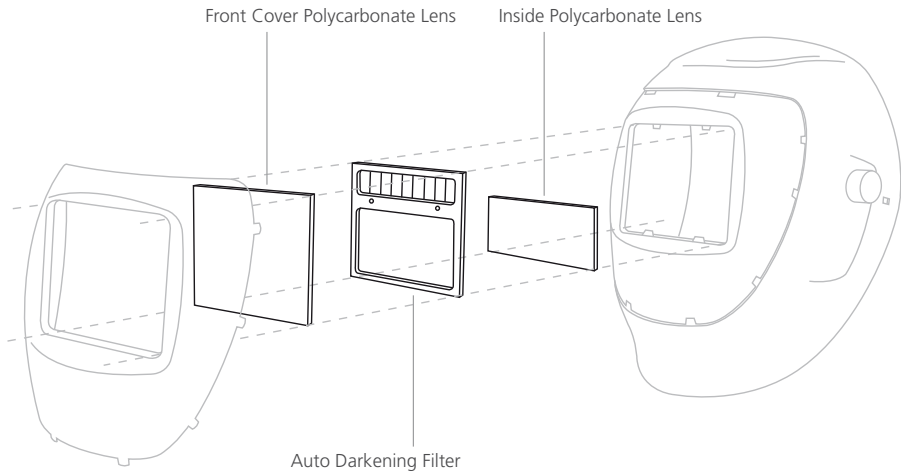

Replacement Parts

Part No	Description
3024	Front Cover Polycarbonate Lens
3042	Auto Darkening Filter Cartridge
1985	Inside Polycarbonate Lens
3028	Sweatband
3029	Headgear Assembly (kit)

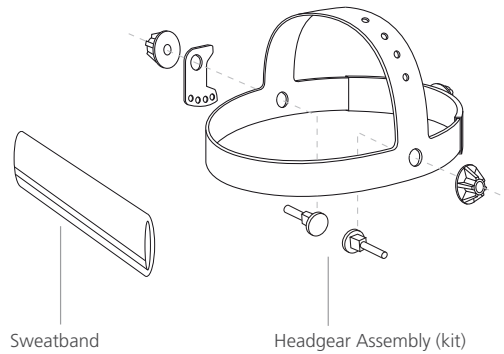

Automatic Welding Helmet
Instruction Manual

