

Air **14**
Equipment

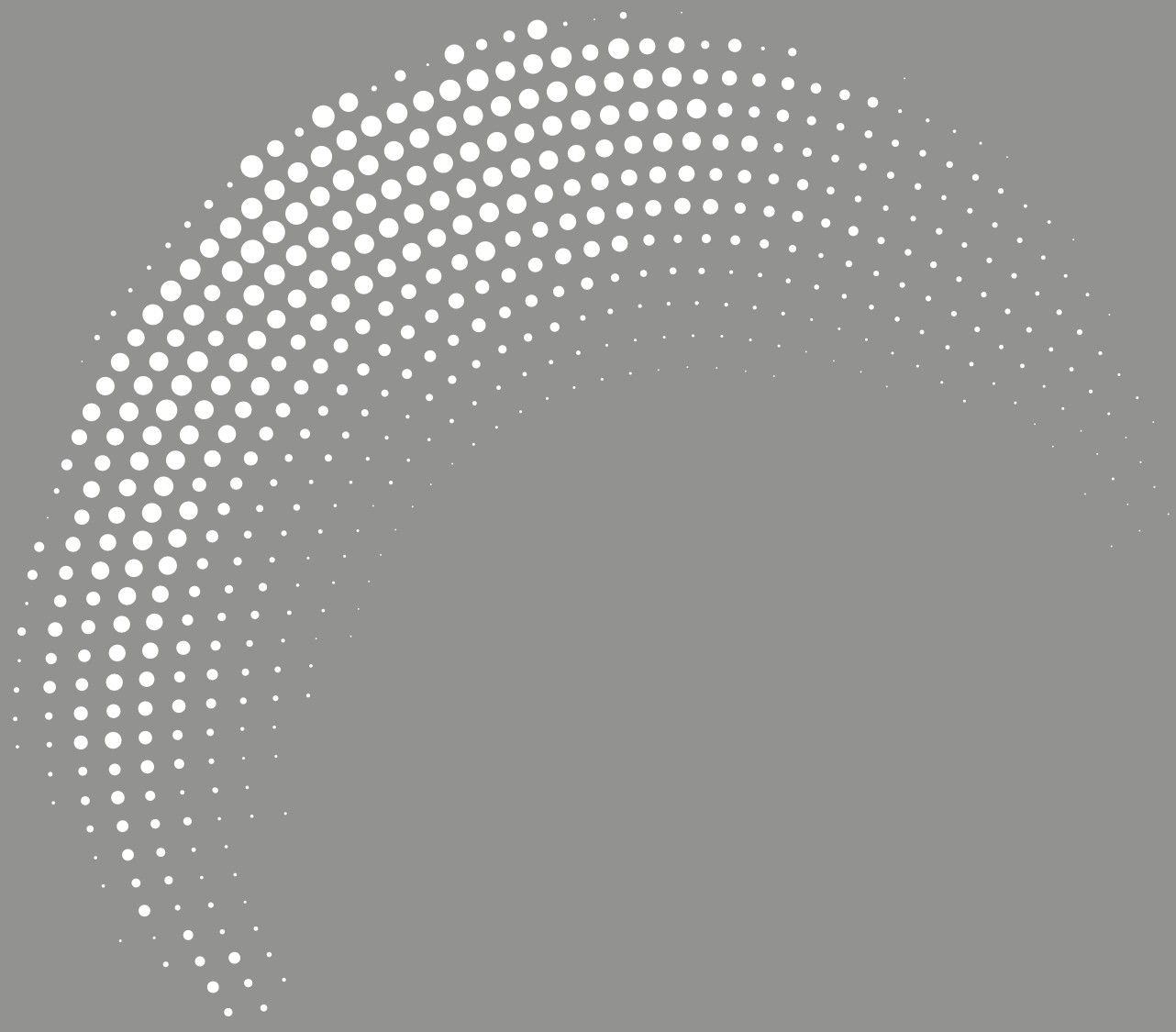

Conversion Factors

Force

	KGF	N	LBF
KGF	1	9.8067	2.2046
N	0.102	1	0.2248
LBF	0.4536	4.4482	1

Weight

	G	KG	LB
G	1	0.001	0.0022
KG	1000	1	2.2046
LB	453.59	0.45359	1

Torque

	LBF-IN	LBF-FT	KGF-C	KGF-M	N-M
LBF-IN	1	0.083	1.152	0.0115	0.113
LBF-FT	12	1	13.83	0.138	1.356
KGF-CM	0.868	0.072	1	0.01	0.098
KGF-M	86.8	7.233	100	1	9.807
N-M	8.851	0.783	10.2	0.102	1

Length

	MM	CM	M	IN	FT
MM	1	0.1	0.001	0.0394	0.0033
CM	10	1	0.01	0.3937	0.0328
M	1000	100	1	39.371	3.2809
IN	25.4	2.54	0.0254	1	0.0833
FT	304.79	30.479	0.3048	12	1

Pressure

	KGF/CM ²	BAR	KPA	LB/IN ² (PSI)	ATM
KGF/CM ²	1	0.8907	98.0665	14.2231	0.9678
BAR	1.0197	1	100	14.5036	0.9869
KPA	0.0102	0.01	1	0.145	0.0097
LB/IN ² (PSI)	0.0703	0.069	6.895	1	0.0680
ATM	1.0332	1.0133	101.325	14.6957	1

Flow

	L/SEC	L/MIN	M ³ /H	M ³ /MIN	GA/MIN	FT ³ /H	FT ³ /MIN (CFM)
L/SEC	1	60	3.6	0.06	13.197	127.14	2.119
L/MIN	0.0167	1	0.06	0.001	0.23	2.119	0.0353
M ³ /H	0.2778	16.6667	1	0.0167	3.6658	35.3165	0.5886
M ³ /MIN	16.666	1000	60	1	219.95	2119	35.3165
GA/MIN	0.0758	4.5465	0.2728	0.0045	1	9.6342	0.1606
FT ³ /H	0.0079	0.4719	0.0283	0.0005	0.1038	1	0.0167
FT ³ /MIN (CFM)	0.4719	28.3152	1.6989	0.0283	6.2279	60	1

Contents

Compressors & Accessories	406-415
Spray Guns & Accessories	416-418
Heavy Duty Air Tools	
Impact Wrenches	420-427
Impact Ratchet Wrenches	428-429
Angle Impact Wrench	430
Die Grinders / Eraser	431-433
Micro Die Grinders	433
Angle Grinders	434-435
Cut-Off Tools	436
Cutters	437
Saws	438
Screwdrivers	439
Drills	440-441
Percussive Tools	442-443
Hydraulic Riveters / Adaptors	444-445
Sanders / Polishers	446-448
Belt Sanders	449
Auto Multiple Tool Kit	450
Auto Repair & Tapping Tool	451
Auto Repair Tools	452-453
Impact Socket Sets & Tools	454-457
Accessories – Miscellaneous	458
Torque Wrenches	458
Display Stands	459

BA106

Portable
1.5 HP / 6 L
Oil Free



- Cast iron cylinder block for longer durability
- Soundproof housing for reduced noise level
- Rubber shock absorbers for less vibration
- Large pressure gauge and regulator
- Roll bar to protect pressure switch assembly from damage

BA224

Portable
2 HP / 24 L
Lubricated



- Cast iron cylinder block for longer durability
- 2 x pressure gauges and regulator assembly
- Wide front leg c/w shock absorber for reduced vibration and good stability
- Ergonomic motor and cylinder cowl for extra protection and efficient cooling
- Carry handle – also protects pressure switch from damage
- Clearly visible oil sight glass

BA250

Portable
2 HP / 50 L
Lubricated



- Cast iron cylinder block for longer durability
- Large heavy duty wheels for all terrains
- 2 x pressure gauges and regulator assembly
- Twin front legs c/w shock absorbers for reduced vibration and good stability
- Ergonomic motor and cylinder cowl for extra protection and efficient cooling
- Carry handle – also protects pressure switch from damage
- Clearly visible oil sight glass

BA350

Portable
3 HP / 50 L
Lubricated



- Cast iron cylinder block for longer durability
- Large heavy duty wheels for all terrains
- 2 x pressure gauges and regulator assembly
- Twin front legs c/w shock absorbers for reduced vibration and good stability
- Ergonomic motor and cylinder cowl for extra protection and efficient cooling
- Long carry handle for easy manoeuvre
- Clearly visible oil sight glass and oil dipstick

Part No.	Horse-power HP	Tank Size L	Working Pressure Bar	Piston Displacement CFM	Voltage V	Lubricated	Dimensions L x W x H cm	Net Weight kg
BA106	1.5	6	8.0	5.65	230	Oil Free	36 x 30 x 48	11
BA224	2	24	10.0	7.77	230	Lubricated	61 x 31 x 58	25
BA250	2	50	10.0	7.77	230	Lubricated	77 x 43 x 66	33
BA350	3	50	10.0	10.95	230	Lubricated	94 x 32 x 70	37



Belt Driven
Portable



A powerful range of single phase compressors that can be run off 230 volt, 13 and 16amp electrical supply.

A professional range of compressors designed for craftsmen, medium sized workshops and contractors where mobility and stability are required.

- All pumps are fitted with a cast Iron cylinder for increased cooling
- Full sized pumps with large oil sump for increased lubrication and clear oil sight glass
- Special non-wear construction conrods and robust cast Iron crankshafts
- Efficient cooling thanks to the aluminium heads and large after cooling fins
- Large, multi-bladed flywheel for maximum cooling of the pump surrounded by heavy duty steel construction belt guard
- Heavy duty wheel kits with rubber gripped handle, two lockable jockey wheels for increased stability and easy manoeuvring
- Twin outlet pressure regulator fitted to all models with large pressure gauge
- Single phase electric motors fitted with thermal overload protection
- Automatic stop/start pressure switches fitted with soft start valves, prewired
- Machines fully CE certified and manufactured in accordance with EN ISO9001

Part No.	Receiver Size L	Motor HP / kW	Maximum Pressure Bar	Piston Displacement CFM	Free Air Delivery CFM	Dimensions L x W x H cm	Net Weight kg	Phase
BA2/100BP	100	2.0 / 1.5	10	9.1	6.3	101 x 41 x 90	56	1*
BA3/50BP	50	3.0 / 2.2	10	13.9	10.1	94 x 41 x 80	58	1**
BA3/100BP	100	3.0 / 2.2	10	13.9	10.1	100 x 41 x 90	71	1**
BA3/150BP	150	3.0 / 2.2	10	13.9	10.1	138 x 42 x 95	87	1**

*13 amp supply required / **16 amp supply required

Belt Driven Static



A powerful range of single and three phase compressors designed with larger volumes of air and higher working pressures to meet the demands of professional and industrial applications. Ideal for larger size workshops, or where higher demands of air and heavier duty applications are required.

- All pumps are fitted with a cast Iron cylinder for increased cooling
- Full sized pumps with large oil sump for increased lubrication and clear oil sight glass
- Special non-wear construction conrods and robust cast Iron crankshafts
- Efficient cooling thanks to the aluminium heads and large after cooling fins
- Precision piston rings fitted to lightweight pistons provide optimum performance
- Two stage pumps fitted with additional aftercoolers for increased cooling between compression stages
- Special design valve plates with higher load resistance
- Cast-Iron high-pressure pistons fitted to NS39 and NS59S pumps which reduces the wear of the conrods and further increase the lifetime of the compressor
- Large, multi-bladed flywheel for maximum cooling of the pump surrounded by heavy duty steel construction belt guard
- Single and three phase electric motors fitted with thermal overload protection.
- Automatic stop/start pressure switches fitted with soft start valves, prewired
- Unload solenoid valve on all models with star delta starter
- Machines fully CE certified and manufactured in accordance with EN ISO9001

Part No.	Receiver Size	Motor	Maximum Pressure	Piston Displacement	Free Air Delivery	Dimensions	Net Weight	Phase
	L	HP / kW	Bar	CFM	CFM	L x W x H cm	kg	
BA3/150BS1	150	3.0 / 2.2	10	13.9	10.1	138 x 42 x 95	87	1*
BA3/150BS3	50	3.0 / 2.2	10	13.9	10.1	138 x 42 x 95	87	3
BA3/200BS1	200	3.0 / 2.2	10	13.9	10.1	150 x 45 x 96	131	1*
BA3/200BS3	200	3.0 / 2.2	10	13.9	10.1	150 x 45 x 96	131	3
BA4/270BS1	270	4.0 / 3.0	10	17.1	11.9	153 x 60 x 116	140	1**
BA55/270BS3	270	5.5 / 4.0	11	23.1	17.8	152 x 59 x 126	180	3
BA75/270BS3	270	7.5 / 5.5	11	29.2	23.2	152 x 59 x 126	210	3
BA10/270BS3*	270	10.0 / 7.5	11	42.7	34.1	152 x 59 x 126	220	3

*16 amp supply required / **32 amp supply required



Belt Driven
Silent



The Balma FELP SILENT has been crafted specifically with professional and industrial users in mind where low noise levels are required. The newly designed canopy comes in various configurations based on your air needs and features a robust thick metal canopy and sound-proofing foam.

- All pumps are fitted with a cast Iron cylinder for increased cooling
- Full sized pumps with large oil sump for increased lubrication and clear oil sight glass
- Special non-wear construction conrods and robust cast Iron crankshafts
- Efficient cooling thanks to the aluminium heads and large after cooling fins
- Precision piston rings fitted to lightweight pistons provide optimum performance
- Two stage pumps fitted with additional aftercooler for increased cooling between compression stages
- Simple belt tensioning thanks to the easy belt slider construction
- Low noise levels due to the noise insulating foam on all canopy sides
- Lower outlet temperature provided by extended aftercooler pipe
- Integrated air damper to aid further reduction in noise levels
- Hinged cubicle for easy access to motor and serviceable components
- Three phase electric motors fitted with thermal overload protection
- Clear visible control panel with hours run counter, pressure gauge and light indicators
- Machines fully CE certified and manufactured in accordance with EN ISO9001

Part No.	Receiver Size L	Motor HP / kW	Maximum Pressure Bar	Piston Displacement CFM	Free Air Delivery CFM	Dimensions L x W x H cm	Noise Level db(A)	Net Weight kg	Phase
BALN55/270BS3	270	5.5 / 4.0	11	23	17.8	151 x 74 x 151	73	220	3
BALN75/270BS3	270	7.7 / 5.5	11	29.21	19.5	138 x 42 x 95	77	355	3

Belt Driven Petrol



Versatile engine driven air compressors for remote applications, from small building contractors, larger construction companies to farmers, the engine AIR range has everything you need. With these engine driven compressors you will be totally independent from any power sources.

- All pumps are fitted with a cast Iron cylinder for increased cooling
- Full sized pumps with large oil sump for increased lubrication and clear oil sight glass
- Special non-wear construction conrods and robust cast iron crankshafts
- Efficient cooling thanks to the aluminium heads and large after cooling fins
- Solid heavy-duty pneumatic wheels and ergonomic handle fitted for all terrains
- The latest GP & GX Honda Petrol engines fitted as standard
- Idling and speed regulators fitted as standard
- Double outlet pressure reducer and gauge fitted as standard, shockproof glycerine bath receiver gauge
- Large, multi-bladed flywheel for maximum cooling of the pump surrounded by heavy duty steel construction belt guard
- Machines fully CE certified and manufactured in accordance with EN ISO9001

Part No.	Receiver Size L	Motor HP / kW	Engine	Maximum Pressure Bar	Piston Displacement CFM	Free Air Delivery CFM	Dimensions L x W x H cm	Noise Level db(A)	Net Weight kg
BA48/100Petrol	100	4.8 / 3.6	GP160	10	14.5	9.5	111 x 52 x 94	76	76
BA9/270Petrol	270	8.4 / 6.3	GX270	10	19.5	14.7	154 x 63 x 116	77	183

Belt Driven Static/Vertical



Ideal for contractors and medium sized workshops where higher demands of air are required but space is at a premium.

- All pumps are fitted with a cast Iron cylinder for increased cooling
- Full sized pumps with large oil sump for increased lubrication and clear oil sight glass
- Special non-wear construction conrods and robust cast iron crankshafts
- Efficient cooling thanks to the aluminium heads and large after cooling fins
- Large, multi-bladed flywheel for maximum cooling of the pump surrounded by heavy duty steel construction belt guard
- Single phase electric motors fitted with thermal overload protection
- Automatic stop/start pressure switches fitted with soft start valves, prewired
- Machines fully CE certified and manufactured in accordance with EN ISO9001

Part No.	Receiver Size L	Motor HP / kW	Maximum Pressure Bar	Piston Displacement CFM	Free Air Delivery CFM	Dimensions L x W x H cm	Noise Level db(A)	Net Weight kg	Phase
BA3/150VBS1	150	3.0 / 2.2	10	13.9	10.1	85 x 97 x 195	73	160	1*

*16 amp supply required

Screw Micro Silent/Static



The BALMA Brio series of screw compressors, BALMA have created a market leading small screw compressor bringing the latest technology, increased market leading performance of 15%, whilst reducing your energy consumption by 12%.

- The Balma Brio range comes with an IE3 premium efficiency motor to give continuous operation as well as energy savings
- The Balma Brio features a newly designed air end that delivers 15% more air and is 12% more efficient than its predecessor. The screw air end allows for continuous operation without cool-down periods
- Sound attenuating canopy reduces sound emissions to comfortable levels, as low as 61 Db(A) making the Balma Brio range, perfect for point of use applications
- The Balma Brio range is fully suitable for low running hours supported by multiple options (optional extra), also suitable for operation at high ambient temperatures up to 46°C
- Latest refrigerant gas (R513A) offering -55%GWP, low pressure drops inside the dryer whilst the wet tank receiver reduces the load
- Long service intervals and external oil level check, quick access to air and oil filters, air oil separator, oil fill and drain make for easy maintenance
- Making the Balma Brio range a best in class offering, food grade oil, oil heater for intermittent use, 500 litre tank for increased productivity, line filter for improved quality air, and timer drain for automatic condensate removal, just to name a few
- Machines manufactured in accordance with EN ISO9001/ISO14001

Part No.	Model	Receiver Size L	Motor HP / kW	Maximum Pressure Bar	Piston (FAD) CFM	Noise Level db(A)	Dimensions L x W x H cm	Dryer	Net Weight kg	Phase
4152055228	BRI02.2 8 230/1/200	200	3.0 / 2.2	8	12.9	61	143 x 60 x 126	No	165	1*
4152055229	BRI02.2 10 230/1/200	200	3.0 / 2.2	10	10.4	61	143 x 60 x 126	No	165	1*
4152055230	BRI02.2E 8 230/1/200	200	3.0 / 2.2	8	12.9	61	143 x 60 x 126	Yes	190	1*
4152055231	BRI02.2E 10 230/1/200	200	3.0 / 2.2	10	10.4	61	143 x 60 x 126	Yes	190	1*



Screw Plus Silent/Static



The BRIO IE3 motor delivers a 100% duty cycle whilst reducing its carbon foot print of -55% GWP using the latest R513A refrigerant gas coupled with ultra low noise levels to make the BALMA range an excellent machine for point of use application. A full package offering best in class.

- The Balma Brio range comes with an IE3 premium efficiency motor to give continuous operation as well as energy savings
- The most advanced technologies in rotor design and oil housing, optimized seal arrangements and bearings offers reliability, efficiency and robustness
- Sound attenuating canopy reduces sound emissions to comfortable levels, as low as 61 Db(A) making the Balma Brio range perfect for point of use applications
- Latest refrigerant gas (R513A) offering -55%GWP, low pressure drops inside the dryer whilst the wet tank receiver reduces the load
- For continuous use, thanks to the 100% duty cycle motor, the Balma Brio compressor range is 30% more efficient than piston compressors and, due to less vibrations and fewer moving parts, have a longer lifetime
- The reliable Balma Brio range is fully suitable for low running hours supported by multiple options (optional extra), also suitable for operation at high ambient temperatures up to 46°C
- The efficient coaxial cooling fan provides excellent cooling of all internal components which leads to higher efficiency and better reliability in operation
- Long service intervals and external oil level check, quick access to air and oil filters, air oil separator, oil fill and drain make for easy maintenance
- The Infologic controller offers advanced monitoring of your equipment whilst being a simple day to day user configuration. Pressure and temperature readings, running and load hours, maintenance warnings, failure alarms, fast pressure settings are displayed directly on the controller
- Machines manufactured in accordance with EN ISO9001/ISO14001

Part No.	Model	Receiver Size L	Motor HP / kW	Maximum Pressure Bar	Piston (FAD) CFM	Noise Level db(A)	Dimensions L x W x H cm	Dryer	Net Weight kg	Phase
4152023422	BRIO 7.5X 8 400/270	270	10.0 / 7.5	8	40.3	65	154 x 72 x 134	No	250	3
4152023423	BRIO 7.5X 10 400/270	270	10.0 / 7.5	10	35.2	65	154 x 72 x 134	No	250	3
4152023427	BRIO 11E 8 400/270	270	15.0 / 11.0	8	57.2	69	154 x 72 x 134	Yes	265	3
4152023428	BRIO 11E 10 400/270	270	15.0 / 11.0	10	50.0	69	154 x 72 x 134	Yes	265	3

BALMA N-Series Replacement Pumps

The BALMA NS pump has been manufactured in Turin Italy since 1950. During the years the continuing research, development and processes has allowed BALMA to maintain a complete high quality range of heavy duty pumps with cast iron components to meet professional and industrial users needs.

All compressor components are made in-house using the latest machines to achieve efficiency and flexibility whilst retaining high quality and consistent standards – all matched by high level certified standards.

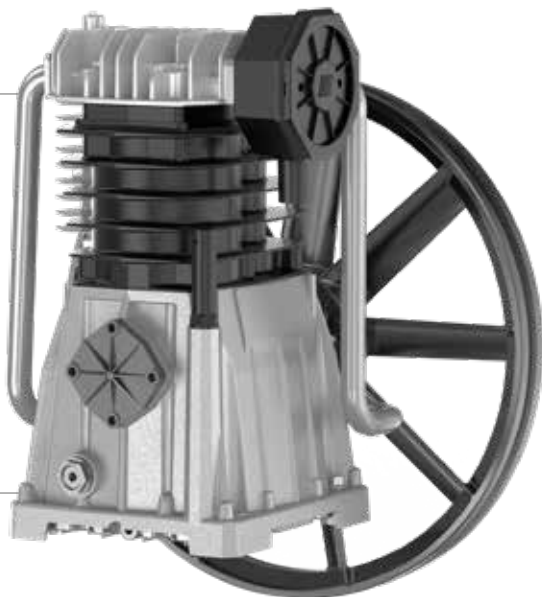

Accessories & Spare Parts

Service Kits

- 8973037657 NS12 / NS19S
- 8973037638 NS39
- 8973037640 NS59S

Air Filter

- 2236112735 NS12 / NS19S
- 8973037875 NS39
- 8973037873 NS59S

Compressor Pumps

- 4116090295 NS12
- 4116090298 NS19S
- 6218739900 NS39
- 6218740300 NS59S

Pressure Switches

Single Phase

- 55884878 Nema
- TMQ Telemecanique

Nema 3 Phase

- 55894380 4-6 Amp
- 55894398 6-10 Amp
- 55894406 10-16 Amp

Condor

- 93184430 2-4 Amp
- 93184448 4-6 Amp
- 93184455 6-10 Amp
- 93184463 10-16 Amp



Compressors Spare Parts – ARIA

NEWCO N-Series Replacement Pumps

Designed in 1982, the NEWCO pump has become an industry leader in a constantly evolving market, offering a quality pump which is recognised the world over. The Newco range is one of the most complete in its field, with the entire production taking place in Avellino, Italy. From here the manufacturing process begins with aluminium casting through to machining, assembly, testing and packaging – allowing the range to be completely supplied from individual parts to service kits.



Available in
2.8hp - 10hp

Accessories & Spare Parts

Service Kits

- 91894881 N2.8/NG2.8
- 91899062 N3/NG3
- 97155576 N4/NG4
- 55893622 N5/NG5
- 97159594 N6/NG6
- 55893622 NV10/NGV10

Pressure Switches

Single phase

- 55884878 Nema
- TMQ Telemecanique

Nema 3 phase

- 55894380 4-6 Amp
- 55894398 6-10 Amp
- 55894406 10-16 Amp

Condor

- 93184430 2-4 Amp
- 93184448 4-6 Amp
- 93184455 6-10 Amp
- 93184463 10-16 Amp

Air Filters

- 97021711 N2.8
- 97021745 N3/N4
- 55898928 N5 New Gen
- 97235899 N5 Old Gen
- 55898928 N6/NG6 New Gen
- 97018402 N6/NG6 Old Gen
- 55898928 NG10/NGV10 New Gen
- 97235899 NG10/NGV10 Old Gen

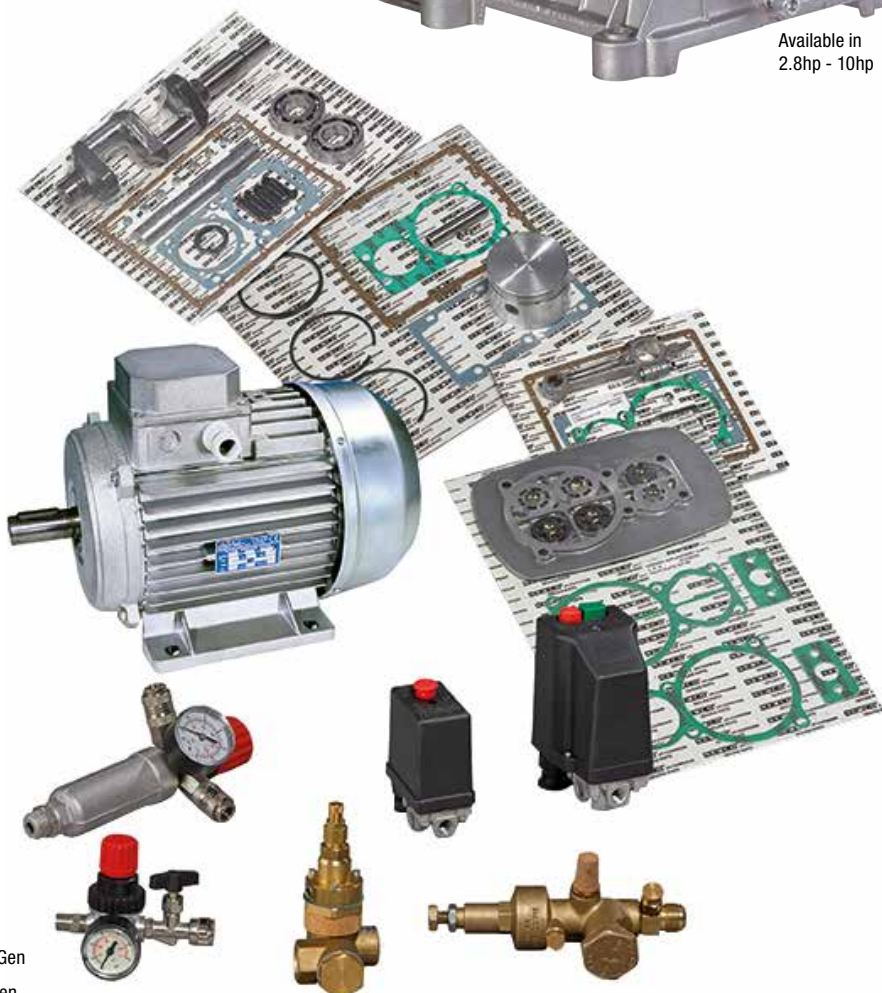

S-35G

Premium Gravity Fed

- High end automotive finishing
- World class atomisation for reduced costs
- The only no-need-to-replace nozzle (worldwide patent pending)
- Forged aluminium body, fine polished and anodised
- Performance, life and field tested
- Supplied with unique foldable S35 stand



S-35S

Premium Suction Fed

- High end automotive finishing and high quality woodworking
- World class atomisation to reduce paint loss and costs
- Forged aluminium body, fine polished and anodised
- Performance, life and field tested
- Comfortable spring loaded handle, ergonomically designed for user comfort



S-701

Suction Fed



S-701R

Suction Fed c/w Regulator



S-770P

Pressure Fed



S-770S

Suction Fed



- High quality fine atomisation
- Ideal for preparation of surface prior to final top coat, such as automotive vehicles, furniture, machinery and general metalwork
- Adjustable nozzles sets ensure constant high performance
- Air inlet 1/4"

- Choice of pressure or suction feed
- Ideal for preparation of surface prior to final top coat, such as automotive vehicles, furniture, machinery and general metalwork
- Adjustable nozzles sets ensure constant high performance
- Air inlet 1/4"

Part No.	Air Pressure PSI (Bar)	Air Consumption CFM	Cup Capacity ml	Nozzle mm	Feed Type
S-35G	50 (3.5)	16	600	14, 17	Gravity
S-35S	50 (3.5)	16	1000	17, 20	Suction
S-701	50 (3.5)	17	1000	1.8	Suction
S-701R	50 (3.5)	17	1000	1.8	Suction
S-770-12	50 (3.5)	12	1000	1.2	Suction
S-770S-15	50 (3.5)	12	1000	1.5	Suction
S-770S-20	50 (3.5)	12	1000	2.0	Suction

MINI6

Pro Touch-Up

- Designed and manufactured for the purpose of small area coating, repair or maintenance
- Improved atomising performance
- Ergonomic grip shape offers improved touch and feel
- 0.5mm fluid nozzle
- 50psi
- Side cup feed



H-827

HVLP Gravity Fed

- Nozzle sizes available 1.4, 1.7 (standard) and 2.0mm
- Durable brass air caps (not aluminium) for long life
- Stainless steel nozzle and needle
- Suitable for water-based paints
- Spray pattern can be adjusted to any object
- Anodised body to reduce need for cleaning
- Air inlet 1/4"



AB-17S

HVLP Suction Fed

- Nozzle sizes available 1.4, 1.7mm (standard)
- Durable brass air caps (not aluminium) for long life
- Stainless steel nozzle and needle
- Suitable for water-based paint
- Spray pattern can be adjusted to any object
- Air inlet 1/4"



AP2000

Spray Gun Set 15 pieces

Contains:

- HVLP 1.3mm Gravity Spray Gun – 600mm
- HVLP 0.8mm Gravity Touch-up Gun – 125mm
- Air Regulator
- Air Blow Gun
- Spare NNG Nozzle Kit
- Supplied in a blow moulded carry case



Part No.	Air Pressure PSI (Bar)	Air Consumption CFM	Cup Capacity ml	Nozzle mm	Feed Type
MINI6	50 (3.6)	?	125	0.5	Side Cup
H-827	43 (3)	15	600	1.7	Gravity
H-827-14	43 (3)	15	600	1.4	Gravity
H-827-20	43 (3)	15	600	2.0	Gravity
AB-17S	43 (3)	16	1000	1.7	Suction
AB-17S-14	43 (3)	16	1000	1.4	Suction

AK-1

Air Tools Kit 5 pieces

Contains:

- Spray Gun
- Washing Gun
- Inflating Gun
- Air Dust Gun
- Air Hose



AK-2

Same features as above but with a gravity fed spray gun

2-QT

Portable High Pressure Paint Pot

- 2 litre cc Paint Pot
- 4 metre Air and Paint Hose
- Carry Handle
- Pressure Gauge
- Regulator



NB: Gun is sold separately – see S-770P on page 416

PT10

Paint Tank

- 10 litre capacity



SK-13

Spray Gun Cleaning Kit 13 pieces



DB-01

Spray Gun Kit



MF-80

Water Trap



HD101

Spray Gun Stand



- Premium free standing gravity spray gun stand
- Solid metal construction
- Foldable for easy storage after use