



Project _____

Item # _____

Quantity _____

Flav-R-Savor® Heated Air Curtain Cabinets

Models: FS2HAC-2PT, -4PT

The patented Hatco Flav-R-Savor® Heated Air Curtain effectively and safely holds hot food hot without the use of doors, allowing immediate access to product.

The models have warm air at the front and back of the cabinet which is forced downward, through the ducts above the opening, forming a “curtain” of heated air. A portion of the heated air is drawn toward the center and sides of the cabinet, warming each pan evenly.

The patented Heated Air Curtain is ideal for holding wrapped product like tortillas, burritos and ribs, as well as product on sheet pans like biscuits, chicken, hamburger patties, pizza and baked potatoes. Holding temperatures range from 80°F to 200°F (27° - 93°C).

Standard features

- Patented air baffle and duct design creates consistent temperature and peak product holding on each pan
- Doorless design allows easy access to food product from both sides
- The four-tiered units which accommodates four (4) full-size sheet pans or eight (8) half-size sheet pans while two-tiered unit accommodates two (2) full-size sheet pans or four (4) half-size sheet pans



FS2HAC-2PT with accessory full size sheet pans



FS2HAC-4PT with accessory full size sheet pans

Accessories

- 4" (102 mm) Legs (standard on FS2HAC-30)

For operation, location and safety information, please refer to the Installation & Operating Manual.





Flav-R-Savor® Heated Air Curtain Cabinets

Models: FS2HAC-2PT, -4PT

FS2HAC-2PT

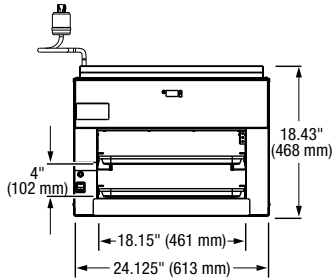

Front View

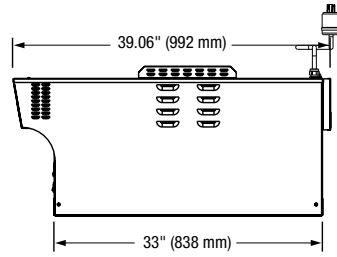

Side View

FS2HAC-4PT

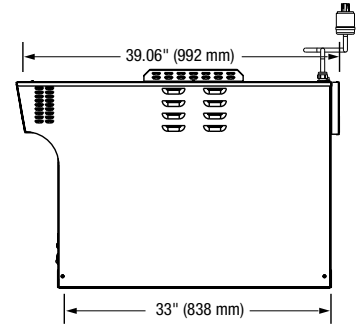
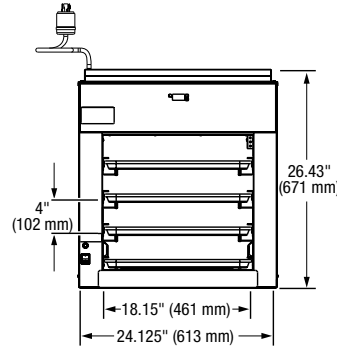

SPECIFICATIONS Heated Air Curtain Cabinets

The shaded areas contain electrical information for International models

Model	Type	Dimensions (W x D x H) <i>Height includes legs</i>	Volts	Hz	Watts	Amps	Plug	Ship Weight*
FS2HAC-2PT	2-Tier Pass-Through	24.125" x 39.06" x 18.43" (613 x 922 x 468 mm)	120/208	60	2589	10.8	NEMA L14-20P	175 lbs. (80 kg)
			120/240	60	2589	10.8	NEMA L14-20P	
			220	60	2538	11.5	NEMA 6-20P, CEE 7/7 Schuko, BS-1363	175 lbs. (80 kg)
			240	60	3022	12.6	NEMA 6-20P	
			220-230 (CE)	50	2538-2774	11.5-12.0	CEE 7/7 Schuko, CEE 17, AS 3112	
230-240 (CE)	50	2774-3022	12.1-12.6	BS-1363, CEE 17, AS 3112				
FS2HAC-4PT	4-Tier Pass-Through	24.125" x 39.06" x 26.43" (613 x 922 x 671 mm)	120/208	60	3389	14.2	NEMA L14-20P	211 lbs. (96 kg)
			120/240	60	3389	14.2	NEMA L14-20P	
			220	60	3338	15.2	NEMA 6-20P, CEE 7/7 Schuko, No Plug	211 lbs. (96 kg)
			240	60	3362	14	NEMA 6-20P	
			220-230 (CE)	50	3338-3646	15.2-15.9	CEE 7/7 Schuko, CEE 17, No Plug	
230-240 (CE)	50	3080-3362	13.4-14.0	CEE 17, AS 3112, No Plug				

* Shipping weight includes packaging.

CORD LOCATION

Top of unit towards the back, left side.

PLUG CONFIGURATIONS

NEMA L14-20P

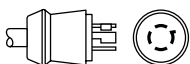

NEMA 6-20P

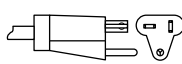

CEE 7/7 Schuko



BS-1363



CEE 17

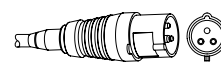

AS 3112



PRODUCT SPECS Heated Air Curtain Cabinets

The patented Heated Air Curtain Cabinet shall be a Flav-R-Savor® Model ... as manufactured by the Hatco Corporation, Milwaukee, WI 53234 U.S.A.

The Heated Air Curtain shall be rated at ... watts, ... volts, and be ... inches (millimeters) in overall width. It shall consist of a powdercoated steel housing, stainless

steel front panel, and metal sheathed heating elements. Heated Air Curtain features easy-to-use digital controls, an On/Off switch, and 6' (1829 mm) cord with plug.

Accessories shall include pan rack.

Warranty consists of 24/7 parts and service assistance (US and Canada only).