

ACART

INSTRUCTION MANUAL



WORK TABLES

(Manual and Electric Height Adjust)



Read and understand all of the instructions and safety information in this manual before operating this product.

Table of Contents

STANDARD FEATURES - WORK TABLES.....	3
Optional Features of the Work Tables.....	3
Model Numbers and Overall Dimensions.....	3
GENERAL SPECIFICATIONS.....	4
Table Installation.....	4
UNPACKING INSTRUCTIONS.....	5
MINIMUM/MAXIMUM ADJUSTABLE HEIGHTS FOR A WORK TABLE.....	6
HEIGHT ADJUSTMENT - MANUAL HYDRAULIC PUMP WITH HANDCRANK.....	7
HEIGHT ADJUSTMENT - MOTORIZED ADJUSTABLE HYDRAULICS.....	8
Work Tables with Electronic Adjustable Height Option - Control Panel Technical Data.....	8
Work Tables with Electronic Adjustable Height Option - Control Panel Setup and Operation.....	9
Replacing the Memory Control Pad.....	11
Installing the Replacement Memory Control Pad.....	12
Programming the Replacement Memory Control Pad.....	13
Instructions for Cleaning Stainless Steel Tables.....	14
Replacement Parts - General.....	15
Limited Lifetime Warranty.....	16

DESCRIPTION OF PRODUCT

This manual covers MAC Medical Work Tables with Manual or Electronic Height Adjust Options.

PURPOSE OF THIS MANUAL

This manual covers the operation and maintenance of the MAC Medical Work Tables with the Manual or Electronic Height Adjust Options.

KEEP THIS MANUAL

STANDARD FEATURES - WORK TABLES

MAC Medical Work Tables come Standard with:

- Fully welded construction
- Reinforced stainless steel top (16 gauge type 300 series)
- Stainless steel undershelf (18 gauge type 300 series)
- 2" square legs
- Added supports
- 5" Casters (two Swivel & two Locking)

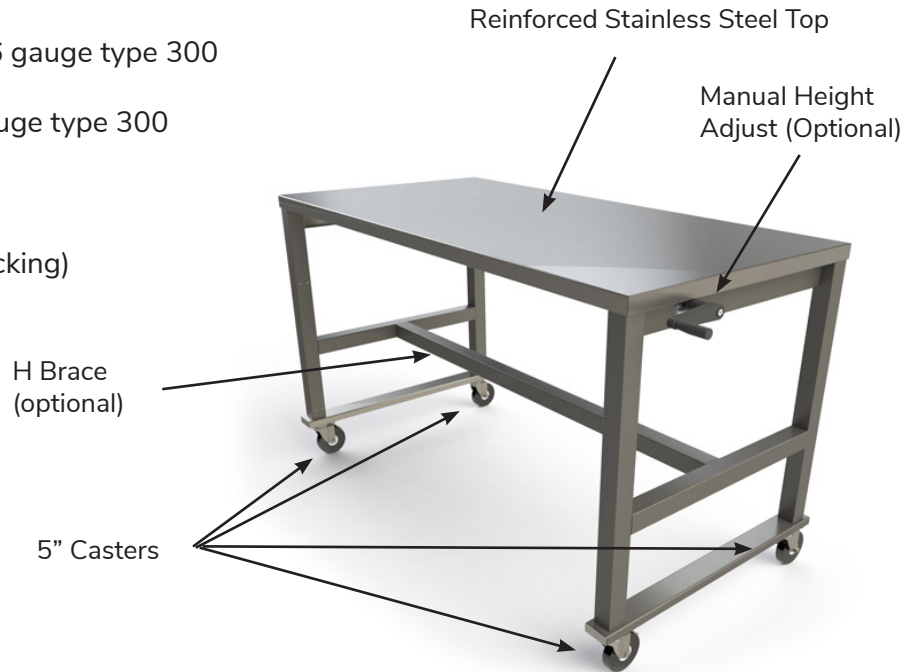

Optional Features of the Work Tables:

- Ergonomically friendly adjustable heights, adjustable manually or electronically
- Manual adjustable height range: 36" - 55"
- Electronic adjustable height range: 36" - 43"
- H or U brace instead of Undershelf
- Full base unit underneath
- Drawers under all sizes
- Stainless steel guard rails
- Multiple undershelves

Model Numbers and Overall Dimensions

Model Number	Overall Dimensions		
	Depth	Width	Height
WT0003	36	24	36
WT0004	48	24	36
WT0005	60	24	36
WT0054	72	30	36
WT0055	72	36	36
WT0059	60	30	36

GENERAL SPECIFICATIONS

Power Requirements:

120 Volt, 60 Hz, single phase, 15 amp GFCI protected electrical outlet, installed per local building codes, and provides protective grounding.

UL Approved:

All individual electronic components are UL approved and/or recognized.

Table Installation

Work Tables with the Electronic Height Adjustment Option require a power source to operate the hydraulics system.

1. Place the table so that its left side (where its power unit is located) is near a 120 VAC GFI power outlet.
2. Plug in the table cord.
3. On the initial start-up, set the maximum and minimum heights on the control pad as shown on pages 9 and 10.
4. After the initial start-up and control pad setting, thereafter simply use the up or down arrow buttons on the control pad to raise or lower the height of the table.

UNPACKING INSTRUCTIONS

Inspection

1. Receiving area must meet all State and Local regulations prior to unpacking.
2. Customer must inspect skid and Table both before and after unpacking to determine if any items were damaged during shipping.
3. All damaged items must be listed on the Bill of Lading.
4. Customer is responsible for the proper disposal of all packing materials. The disposal of these items must meet all State and Local regulations.

Unpacking the Work Table

Work Tables are shipped on well-constructed wooden skids. Two steel bands secure the Table to the skid. The stainless steel surfaces of the part are protected by heavy cardboard end caps, and by layers of plastic wrapping.

Care must be taken while unpacking the table to avoid damage. Do not drop tools on the table or scratch the surfaces with sharp edges.

IMPORTANT: Wear gloves and eyewear during the unpacking operation.

Retain all shipping materials until the table is completely unpacked and inspected for damage.

5. Use tin snips to cut the metal bands holding the box to the wooden skid (Fig 1).
6. Remove metal staples holding one end of the packing carton together.
7. Slide out table from side of packing carton with two attached cardboard end caps (Fig 2).
8. Remove two cardboard end caps.
9. Remove the plastic protective wrapping.



Caution! Do not use a box cutter or any other cutting utensil to remove the plastic wrapping around the table. These items can scratch the protective coating on the stainless steel, allowing the surface to rust.



Fig. 1: Boxed Table



Fig. 2: Wrapped Table with End Caps

10. The Work Table is now ready for use.
11. Discard shipping and packing materials in compliance with state and local regulations.
12. When not in use, tables must not be double stacked while in storage. While still in their shipping cartons, tables must not be double stacked when not in use.

MINIMUM/MAXIMUM ADJUSTABLE HEIGHTS FOR A WORK TABLE

Minimum/Maximum Adjustable Height, Manual Height Adjustment

The Minimum height of a Manual Height Adjust Work Table is 36" (from floor to tabletop).
 The Maximum height of a Manual Height Adjust Work Table is 55" (from floor to tabletop).

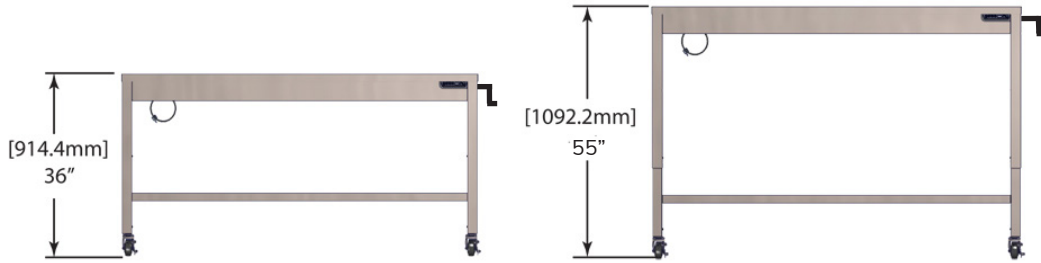

Fig. 3: Manual Height Adjust Minimum/Maximum Heights

Minimum/Maximum Adjustable Height, Electronic Height Adjustment

The Minimum height of an Electronic Adjust Work Table is 36" (from floor to tabletop).
 The Maximum height of an Electronic Height Adjust Work Table is 43" (from floor to tabletop).

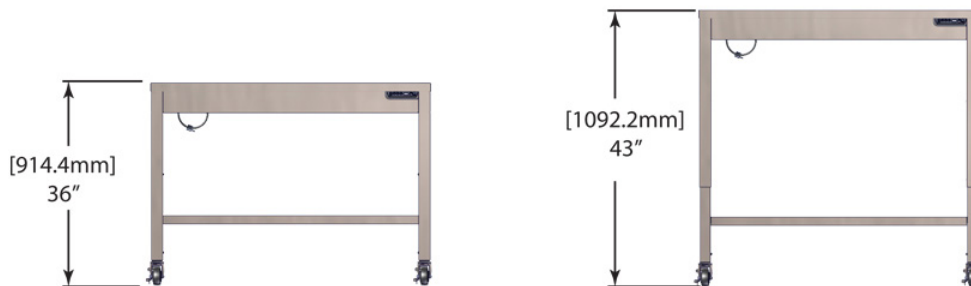

Fig 4: Electronic Height Adjust Minimum/Maximum Heights

HEIGHT ADJUSTMENT - MANUAL HYDRAULIC PUMP WITH HANDCRANK

For Space Saver Tables equipped with the Optional Manual Hydraulic Pump with Handcrank (Figs. 5-6), the Handcrank can be folded to disappear under the table.

1. Crank the table to the desired height.
2. Pull the Crank outward, then rotate downward to fold the handle under the table (Fig. 7).

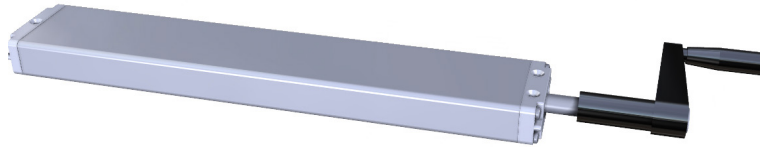

Fig. 5: Manual Hydraulic Pump with Handcrank

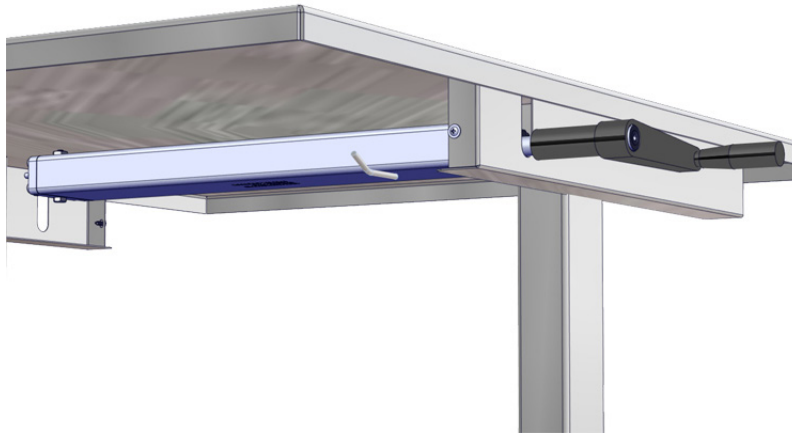

Fig. 6: Hydraulic Pump and Handcrank Location

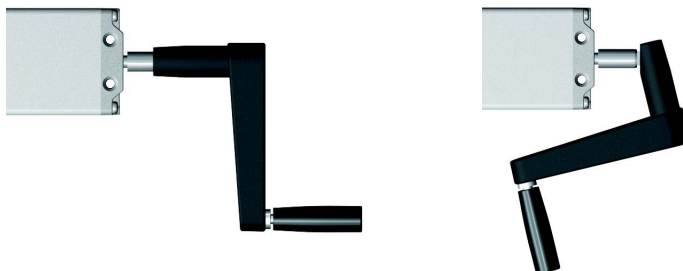

Fig. 7: Hydraulic Pump Handcrank, unfolded and folded

HEIGHT ADJUSTMENT - MOTORIZED ADJUSTABLE HYDRAULICS

Work Tables with Electronic Adjustable Height Option

Control Panel Technical Data

The Control Panel feature is available for a Work Table with the Electronic Adjust Option to operate its hydraulics.

Features	Electrical Specifications
4 Memory Positions	Primary Voltage 120V, 10A
Digital Display of the Height	Engine Voltage 24 VDC
Overload Protection	Nominal Rating Approximately 340 VA
Thermal Protection	Standby Power <0.6W
	Nominal Speed 180 min-1
	Protection Type IP 20

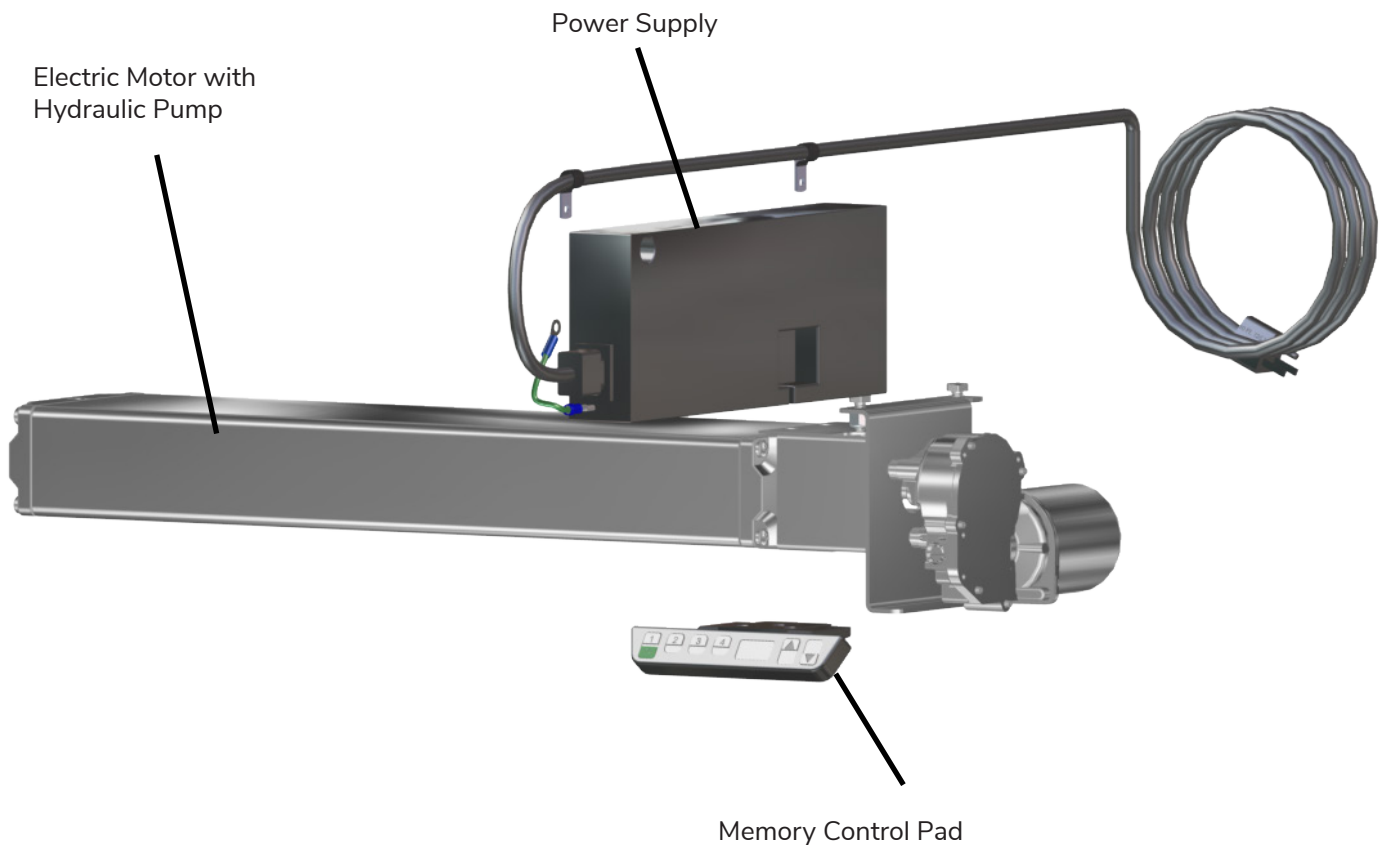

Fig 8: Memory Control Pad, Power Unit, Electric Motor and Hydraulic Pump

Work Tables with Electronic Adjustable Height Option Control Panel Setup and Operation

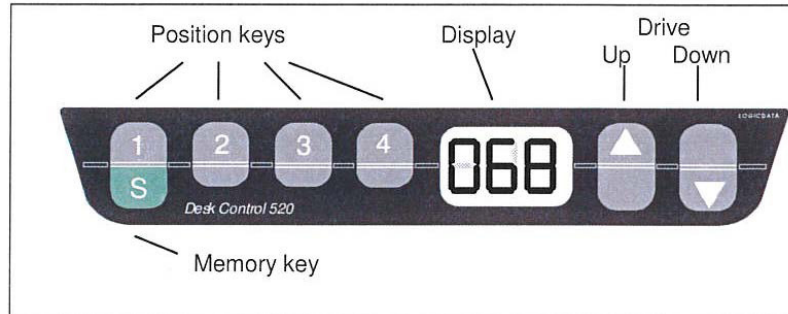

Fig. 9: Memory Control Keypad

At the first power-on, follow these steps:

Note: US customers will see the values in the display in terms of US inches. European customers will see display values in terms of EU Centimeters.

1. First start up

- a. The display will initially flash "027" (US) or "068" (EU).
- b. Press the "Down" arrow button (see illustration above) until the lower US:36"/EU:91 cm end position is reached, checking with a tape measure.
- c. The table moves down with half speed. Moving up is not possible.
- d. Adjust the readout in US inches/EU centimeters to reflect the actual height with the "1" button (plus) and the "2" button (minus).
- e. Moving up or down is not possible.
- f. Press the "S" (green button) to confirm.
- g. After the confirmation the display will flash US:"036"/EU:"091".
- h. Use the "Up" arrow button to move to the upper US:43"/EU:109 cm upper limit, checking with a tape measure.
- i. The table will move at half speed and half power.
- j. Adjust the readout in US inches/EU centimeters to reflect the upper position with the "1" button (plus) and the "2" button (minus).
- k. Confirm with the "S" button.
- l. After confirmation the display will flash "109".
- m. After the confirmation the height is shown and the Control Box is ready for normal operation.

2. Operation up / down

- a. Press the "Down" arrow button or the "Up" arrow button until the desired height of the table has been reached.
- b. The display always shows the actual height in US inches or EU centimeters.
- c. The table moves as long as the key is pressed, or until the end position is reached.

Work Tables with Electronic Adjustable Height Option - Control Panel Setup and Operation (continued)

3. Saving of a position
 - a. This function allows the user to save a particular operating height on one of the four preset buttons.
 - b. Press the “S” button (Display: “5 –”).
 - c. Press one of the following buttons: “1”, “2”, “3”, or “4”.
 - d. After having pressed one of the position buttons listed above, an “S” and one of the position buttons is read on the display (i.e. “S3”).
 - e. At the end of the memory procedure, a double “Click” is heard and after 2 seconds the actual height is read on the display (i.e. “073”).
 - f. If there is a power failure or the unit is unplugged, the programmed presets are retained (up to 24 hours).

4. Reset of the Control Unit
 - a. Press and hold “1”, “2”, and the “Up” arrow at the same time until it flashes “S5”. The control is now in the adjustment mode.
 - Release “1”, “2”, and the “Up” arrow. Press the Up arrow until the display shows “S7”. Then press “S” to set.
 - b. Then press the down arrow. The table will now move down. Checking with a tape measure, lower the table down to US:36”/EU:91 cm.
 - c. Then hold “2” until it reads “000”.
 - Then press “S” to set. It will then display “036”.
 - d. Hold the Up arrow to US:43”/EU:109 cm (check the height with the tape measure).
 - Then press “1” until it reads “109”. Then press “S” to set.

5. Setting of Indicated Height
 - a. Press the “S” button. Display will read “5 –”.
 - b. If the key is not pressed within 5 seconds, the control returns to standard mode again.
 - c. Press the “Down” arrow button now for about 5 seconds until the display starts flashing. (Example: display flashes: “073”).
 - d. The height can also be set with the “Up” (plus) or with the “Down” (minus) arrow buttons. During this procedure the table does not move.
 - e. If the position is correctly set, the new height can be saved by pressing the “S” button.
 - The position is saved and the display stops flashing.
 - The new height is also saved. If no button is pressed within 5 seconds, the display stops flashing automatically.

Replacing the Memory Control Pad



Fig. 10: Remove Old Memory Control Pad

Removing the Existing Memory Control Pad

If the Memory Control Pad must be replaced (due to damage), first remove the existing Memory Control Pad:

1.  **UNPLUG THE TABLE FROM ITS POWER SOURCE.**
2. Remove three 1/4" screws attaching the Controller to the table mounting plate (Fig. 10).
3. Unplug the old Memory Control Pad cord from the Power Supply Unit.
4. Remove the old Memory Control Pad.

Installing the Replacement Memory Control Pad

1. Position the replacement Memory Control Pad on the mounting plate under the front edge of the table. Align the three holes in the control panel with holes in table mounting plate.
2. Insert three 1/4" screws into the holes of the Memory Control Pad, attaching the Memory Control Pad to the table mounting plate (Fig. 11).



Fig. 11: Attach New Memory Control Pad

Item #	Part #	Description	QTY
1	H0090-PBD-110	Memory Control Pad 1 with Power Cord	1
2	H0012-01	Self-Tapping Screws	3

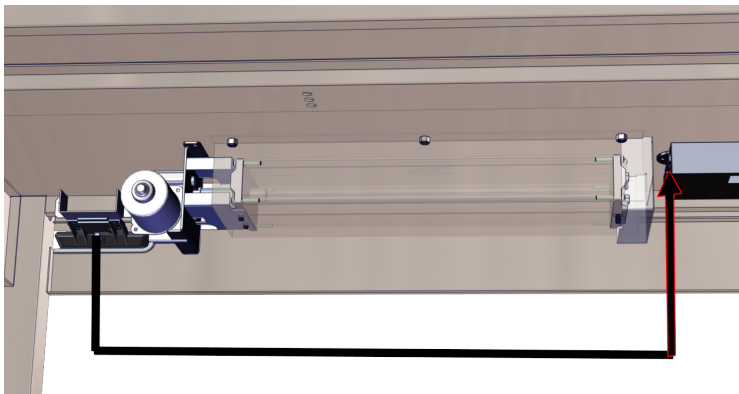

Fig. 12: Plug in Memory Control Pad cord to Power unit

3. Plug the control pad cable into the round receptacle of the table Power Supply Unit (Figs. 12-13).
4. Plug the table cord back into its power source.
5. Program the Replacement Memory Control Pad as shown on page 13.

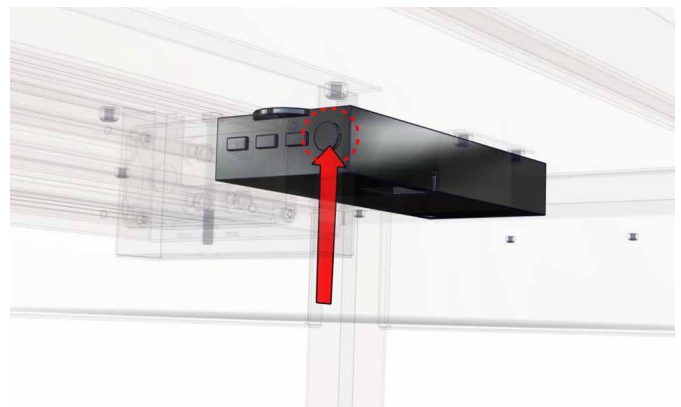
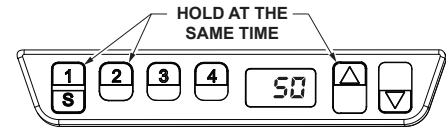

Fig. 13: Power Unit receptacle (viewed from back of table)

Programming the Replacement Memory Control Pad

After the new Memory Control Pad has been installed, it must be programmed.

1. Press and hold Buttons “1”, “2”, and the “UP” Arrow at the same time. The Memory Control Pad is now in the adjustment mode.



2. Release Buttons “1”, “2”, and the “UP” arrow. Press the “UP” arrow until the display reads “S7”.

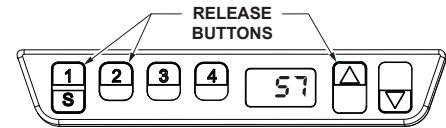

3. Next, press the “S” button.

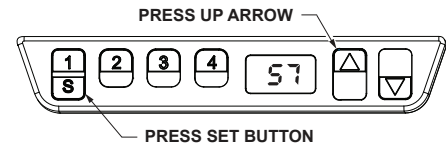

4. Press the “DOWN” Arrow. The table will now move down. Verify height of table is US:36”/EU:91 cm with a tape measure.

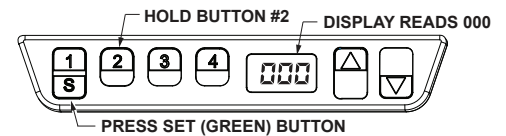

5. Press and hold “2” button until “000” is displayed. Press GREEN (SET) Button. Display will now read “036”.

6. Press and hold “UP” Arrow until the table raises to US:43”/EU:91 cm. Verify height of table is 43” with a tape measure.

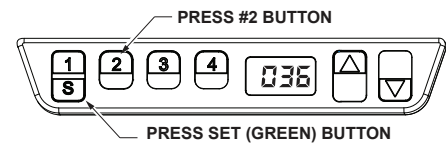

7. Press and hold “1” button until the display reads “109”. Next, press the “S” button.

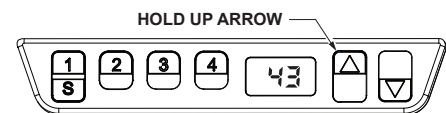

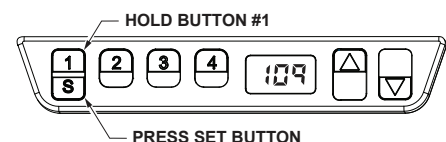

8. The Memory Control Pad is now ready for use.



Instructions for Cleaning Stainless Steel Tables

Space Saver Tables must be cleaned on a regular basis to prevent any unnecessary damage to the stainless steel surfaces.

When cleaning the table, make sure to use the proper approved cleaning agents and cleaning materials.

 CAUTION DO NOT USE these Cleaning Materials	 CAUTION DO NOT USE these Cleaning Agents
Abrasive Pads	Hard Water (water with a pH reading above 7.0)
Scrapers	Hydrochloric Acid
Steel Wool	Steam or high pressure water
Wire Brushes	Bleach or any compounds containing chlorine or Sodium hypochlorate, or ammonium chloride salts

Approved cleaning materials and agents

- Soft, clean lint-free cloth
- Non-abrasive cleaning pads
- Soft bristle brush
- Mild detergents
- Sodium Bicarbonate (baking soda)
- Distilled water (pH rating 7) alone or with a mild detergent
- White vinegar (in a spray bottle)
- Isopropyl Alcohol
- Hospital-grade non-bleach disinfectants
- Cleaners approved for use on stainless steel

Cleaning Stainless Steel Surfaces

1. Using a damp, lint-free cloth and approved cleaner, wipe down the entire exterior surface of the stainless steel table. Using a damp, lint-free cloth with distilled water and a mild detergent, wipe down the entire exterior surface of the stainless steel table.
2. Wipe the steel surface along the direction of its grain as shown below.

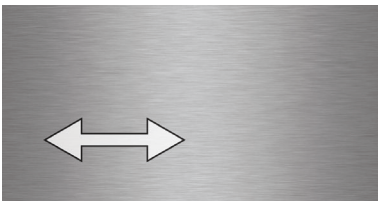

3. Let the cleaned table air dry.

Cleaning Decals or Printed Labels

- Use only distilled water and a mild detergent applied with a clean, dry lint-free cloth to clean decals or printed labels.
- Cleaning agents can remove or smear any printing from decals and print labels.
- Cleaning agents can damage plastic materials used in manufacturing covers for electronic items such as touch-screen pads.

Replacement Parts - General

The Work Table replacement parts listed on this page have been identified by MAC Medical as serviceable by facility personnel and are available for purchase. To obtain MAC Medical certified parts and authorized services, contact your MAC Medical representative.

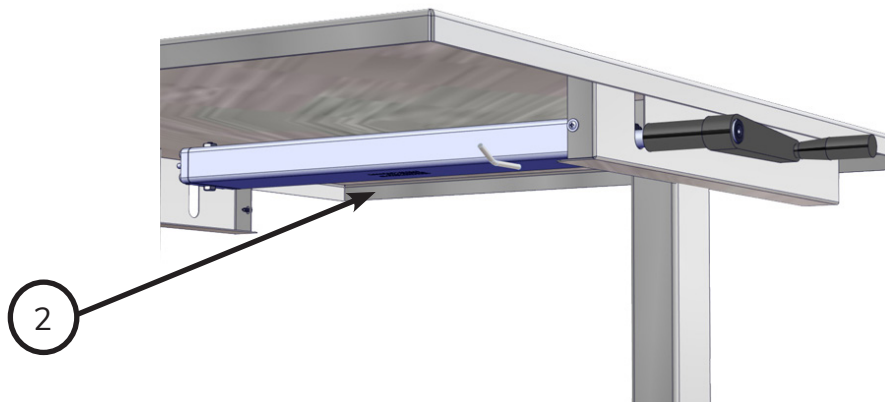

Item ID	Part Number	Description	QTY	Models
1	H0135-5-SS	5" Swivel Caster	2	All
1	H0135-5-LSS	5" Swivel Caster w/Brake	2	All
2	H0090-03	Hydraulic Pump with Crank	1	All

Limited Lifetime Warranty

MAC Medical warrants to the original purchaser that its Proprietary Products will be free from defects in workmanship or materials under normal use and service for the life of the product, so long as owned by the original purchaser, according to the limitations set forth below.

Defective products shall be repaired or replaced at MAC Medical's option at no cost to the original purchaser provided:

1. The customer must obtain a written return authorization supplied by MAC Medical's customer service department. The product must be returned, properly packaged, with a copy of the original sales receipt and copy of the RMA authorization.
Please call (877) 828-9975 or (618) 476-3550 to receive a return authorization.
2. The customer must pre-pay freight charges to and from MAC Medical and must ship merchandise properly packaged, in a way the product will not be damaged during transit to the factory. MAC Medical does not warranty any freight damage to or from the factory. It is the customer's responsibility to inspect the product for packaging damage before signing the BOL.

This warranty does not apply to products, which have been subject to abuse, misuse, accident, modification, alteration, tampering, negligence, lack of routine maintenance or misapplication; or products that have been repaired by other than MAC Medical or its authorized representatives.

This warranty does not apply to glass, fabrics, vinyl, seat coverings, cushions, padding or their stitching, gluing or installation. Component parts not manufactured by MAC Medical, such as casters, caster inserts, any components made from rubber or plastic, circuit boards, fan heaters, plumbing parts, electrical switches and other components are also excluded. For these component parts, MAC Medical will pass on the original manufacturer's warranty to MAC Medical equipment original purchasers. Please consult factory for questions regarding the warranties of these component parts. This warranty does not apply to custom fabricated products. Consult factory.

UNLESS EXPRESSLY SET FORTH IN THIS WARRANTY, THERE ARE NO OTHER WARRANTIES, WHETHER EXPRESS OR IMPLIED, OF FITNESS AND/OR MERCHANTABILITY OR ANY OTHER WARRANTY IMPLIED BY CUSTOM, USAGE OR COURSE OF DEALING.

Liability of MAC Medical under this warranty is limited to the repair and/or replacement of any products. MAC Medical specifically excludes and disclaims any responsibility for any incidental or consequential damages claimed to have arisen from any defect in workmanship or materials. No representative has any authority to change or enlarge the above warranty or MAC Medical liability. This document supersedes all previous warranty provisions.



ACART

1416 Bonhill Rd. Mississauga, ON L5T 1L3

WWW.ACART.CA ~ INFO@ACART.CA ~ 1-800-551-0560

© 2023 Acart Equipment