

# ACART

## INSTRUCTION MANUAL

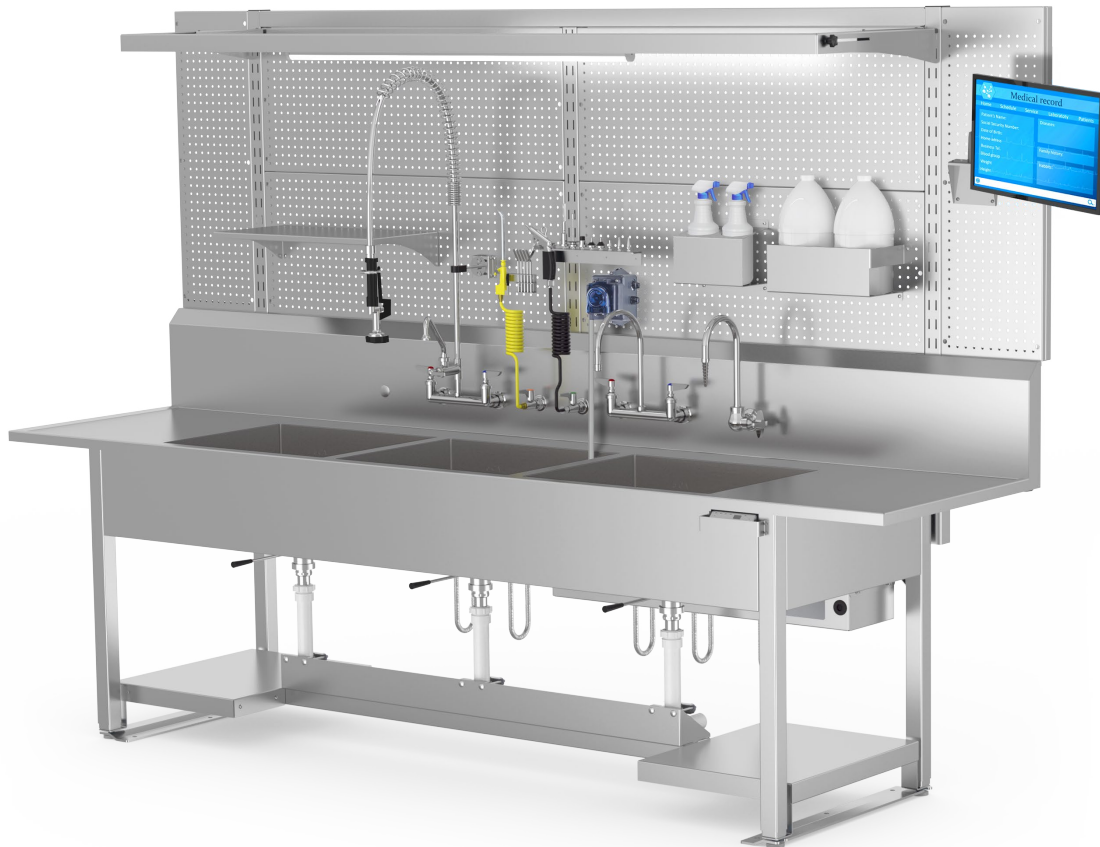

## Fixed and Adjustable Height Processing Sinks

Installation - Operation - Maintenance - Cleaning



**CAUTION**

Read and understand all of the instructions and safety information in this manual before operating this product.

### Table of Contents

Summary.....	3
Warnings and Cautions Icon Key.....	4
Warnings and Cautions When Installing or Operating This Product.....	5
Processing Sink Models.....	6
General Specifications.....	8
Overview of Processing Sink Components.....	10
Unpacking and Inspection Instructions.....	11
Sink Installation Steps.....	12
Sink Placement Requirements.....	13
Install Pegboard Backframe.....	15
Assemble and Install Pre-Rinse Water Faucet (MMKL53-1000-AF2).....	18
Operation and Maintenance of the Pre-Rinse Spray Faucet.....	24
Replaceable Pre-Rinse Water Faucet Parts.....	25
Assemble and Install Air Gun Kit (PSKT-04).....	28
Replaceable Air Gun Kit Parts.....	32
Using and Cleaning the Air Gun.....	33
Assemble and Install Water Gun Kit (PSKT-05).....	34
Safe Use of the Water Gun.....	39
Replaceable Water Gun Kit Parts.....	40
Cleaning Instructions for the Water Gun.....	41
Assemble and Install DI Water Faucet (PSKT-03).....	42
Replaceable DI Water Faucet Parts.....	43
Assemble and Install Gooseneck Water Faucet (PSKT-02).....	44
Replaceable Gooseneck Water Faucet Parts.....	45
Foot Levelers (H0090-05-03) and Floor Anchor (S02212-26-PSFA).....	46
Fixed Height Sink Waste Drains.....	47
Adjustable Height Sink Waste Drains.....	48
Connection to Drain (Adjustable Height Sinks).....	49
Air and Water Connections.....	50
Adjustable Height Sinks Only - Control Panel Technical Data.....	51
Adjustable Height Sinks Only - Control Panel Setup and Operation.....	52
Adjustable Height Sinks Only - Maximum/Minimum Height Levels.....	55
Adjustable Height Sinks Only - Replacing the PCB Enclosure Assembly.....	56
Instructions for Cleaning Stainless Steel Processing Sinks.....	58
Index.....	59
Limited Lifetime Warranty.....	60

### Summary

#### DESCRIPTION OF PRODUCT

This manual covers Processing Sink models -  
Fixed Height Processing Sinks  
Adjustable Height Processing Sinks

#### PURPOSE OF THIS MANUAL







This user manual details the installation,  
operation, maintenance and cleaning of the  
MAC Medical Processing Sinks.

This manual also contains general  
specifications, warnings and cautions.

***KEEP THIS MANUAL***

### Warnings and Cautions Icon Key

The following is a list identifying the various warning and caution icons used in this manual.

Icon Type	Icon	Description
Warnings		(Red triangle with an exclamation point) indicates the potential for minor to severe injuries up to and including death to personnel.
Cautions	 	<p>(Yellow triangle with an exclamation point) indicates the potential for minor injury to personnel and damage to equipment.</p> <p>Note: The exclamation point will not be visible where only equipment damage is present.</p>
Burn Hazard Warnings		(Yellow triangle with radiating lines) indicates a potential burn injury to personnel.
Electrical Warnings		(Yellow triangle with a lightning bolt) indicates a possible shock hazard is present.
		Severe shock hazards shall be a lightning bolt in a red triangle.
Explosion Hazard		(Yellow triangle with the explosion icon) indicates the equipment should not be operated in areas where explosions could occur.

### Warnings and Cautions When Installing or Operating This Product

Prior to installation or operation, the user must read these warnings and cautions.

The following is a list of the safety precautions that must be observed when operating this equipment.



**WARNINGS** indicate the potential for danger to personnel.  
**CAUTIONS** indicate the potential for damage to equipment.

These precautions are repeated (in whole or in part), where applicable, throughout the manual. It is important to review these precautions before using the equipment.



**WARNING - INJURY HAZARD -**

REPAIRS AND ADJUSTMENTS should be attempted only by experienced service agents fully acquainted with this equipment. The use of inexperienced, unqualified persons to service the equipment, or the installation of unauthorized parts, could cause serious personal injury, or result in costly damage. Always unplug power cord from power source prior to attempting any repairs or servicing.



**WARNING -**



DO NOT operate in a potentially explosive atmosphere.



**CAUTION-POSSIBLE EQUIPMENT DAMAGE -**

When cleaning the sink - See complete Cleaning Instructions in this manual.

- Use a non-abrasive polish.
- Rub in a back and forth motion in the same direction of the surface grain.

**DO NOT use bottom shelf to lift sink with jacks!**

NOTE: This product is to be used strictly for the purpose it was designed for. If this product is used in a manner not specified by MAC Medical, the protection provided by the equipment may be impaired. MAC Medical disclaims all liability for the consequences of this product being used for purposes other than its intended design. Product modification or misuse can be dangerous. MAC Medical disclaims all liability for the consequences of product alterations or modifications, as well as for the consequences which might result from the combination of this product with other products, whether supplied by MAC Medical or by or by other manufacturers, unless such a combination has been specifically endorsed by MAC Medical.

### Processing Sink Models

#### Fixed Height (without hydraulic system)

Sinks are available in any multiple basin configuration as required (the fixed height standard single, double and triple basins are shown here).



### Adjustable Height (with hydraulic system)

Sinks are available in any multiple basin configuration as required (the adjustable height standard single, double and triple basins are shown here).

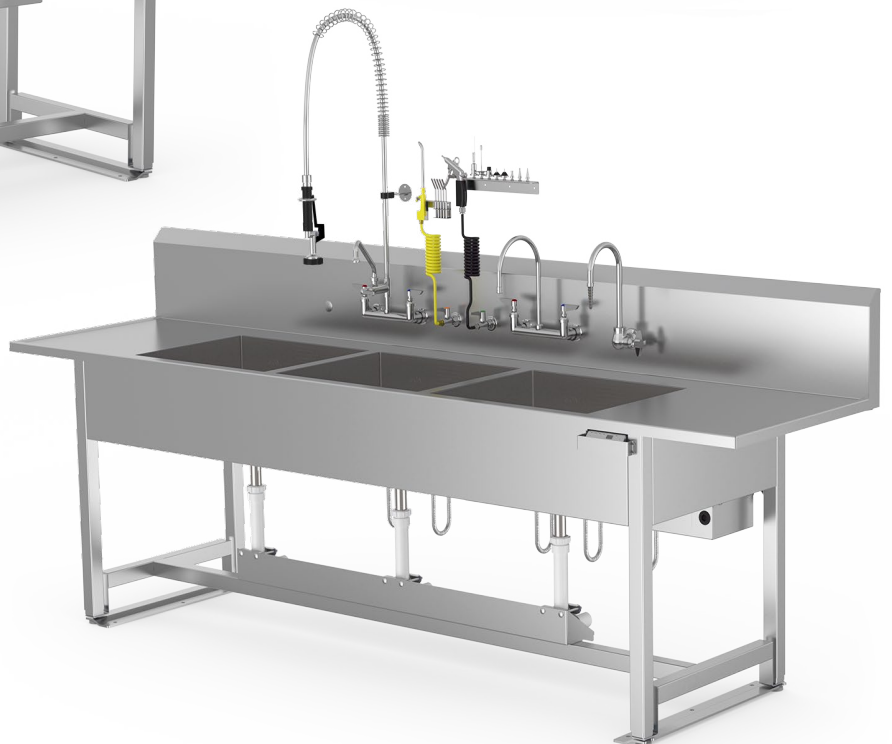
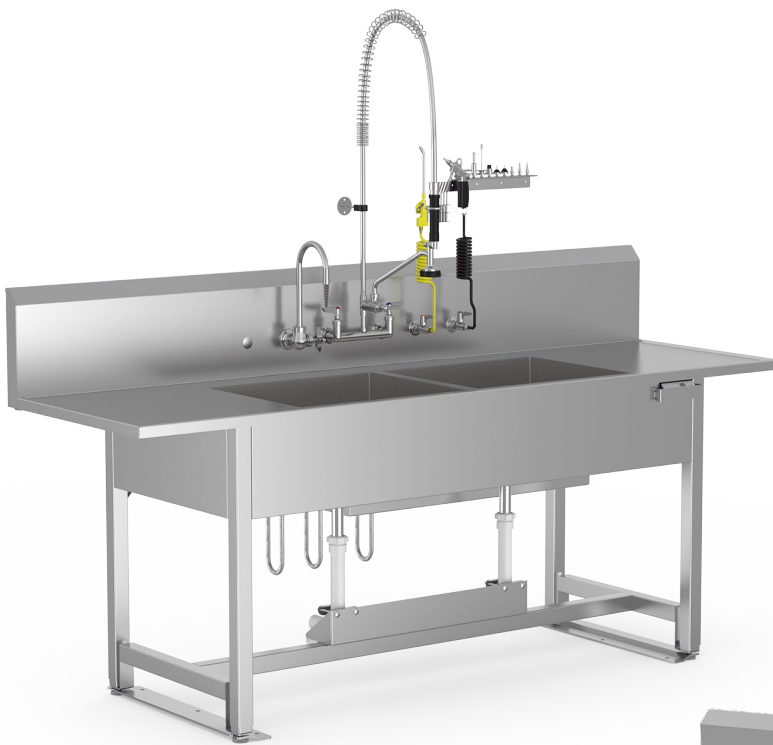

## General Specifications

1. Material:
  - a. Sink basin and sink top: 14 gauge, 300 stainless steel
  - b. Sink skirt: 18 gauge, 300 stainless steel
  - c. H-brace: 16 gauge, 300 stainless steel
  - d. Sink base tubing: 16 gauge 300 stainless steel
2. Plumbing detail
  - a. Fixed height
  - b. Adjustable height
3. Utility requirements:
  - a. It shall be the customer's responsibility to ensure that the incoming water/DI/air supply meets manufacturer's requirements.
  - b. Cold water: 20 to 50 psi 70°F Max.
  - c. Hot water: 20 to 50 psi 120°F to 140°F Max.
  - d. It shall be the customer's responsibility to ensure (by use of pressure regulators or other means) that maximum specified pressures are not exceeded.
  - e. Water lines should be flushed clean before water connections are made.
  - f. It shall be the customer's responsibility to ensure that water supplies are properly protected for internal cross connection control in accordance with local building and plumbing requirements.
  - g. It shall be the customer's responsibility to eliminate water hammer conditions should they occur in the service piping.
  - h. DI water: flow rate 50 psi – 120 psi, rate operating pressure: 20 - 125 psi rated operating temperature: 40° - 140° F.
  - i. Air: quick tip air gun complete with five (5) different tips that are quickly changed by a quick push and pull. Comes with a popular hooked air gun body.
    - The rubber tip and the needle tip should be used with 30 psi Max.
    - Air hose ¼" I.D. X 8 feet flexcoil retracting air and water, brass fittings with NPT threads (1/4" NPT swivel), temp range -40° to +125°F.
    - Vacuum rating is 27"hg @ 72°F. Air inlet deck mount fitting, turret base 3/8" NPT female, single 3/8" NPT female outlet, 3/8" IPS mounting shank with locknut and washer. 3/8" IPS x 2-1/2" OAL.
    - Low-pressure brass threaded pipe fitting 3/8 male x ¼ female pipe size, hex reducing bushing.



4. Power requirements (Adjustable Height Sinks Only):
  - a. 120 Volt, 60 Hz, single phase, 15 amp GFCI protected electrical outlet, installed per local building codes, and provides protective grounding.
  - b. Main power supply voltage fluctuation is not to exceed  $\pm 10\%$  of the nominal supply voltage.
5. Equipment Ratings
  - a. Pollution Degree: 2
  - b. Installation Category: 2
  - c. Altitude: 2000 m
  - d. Humidity: 80% rH to temperature up to 31°C, decreasing linearly to 50% rH at 40°C; max 80% rH, non-condensing.
  - e. Temperatures: 5°C to 40°C (41°F to 104°F)
  - f. Indoor Use only
6. Sink is approved ETL/CETL/CSA/NSF recognition.
7. All individual electronic components are UL approved and/or recognized.

### Overview of Processing Sink Components

The processing sink assemblies or components to be installed or programmed are identified in the table below and will be covered in more detail in this installation manual.

The illustration below shows an adjustable height triple basin sink with all the assemblies as called out in the table below. Other sinks may have different features than shown here.

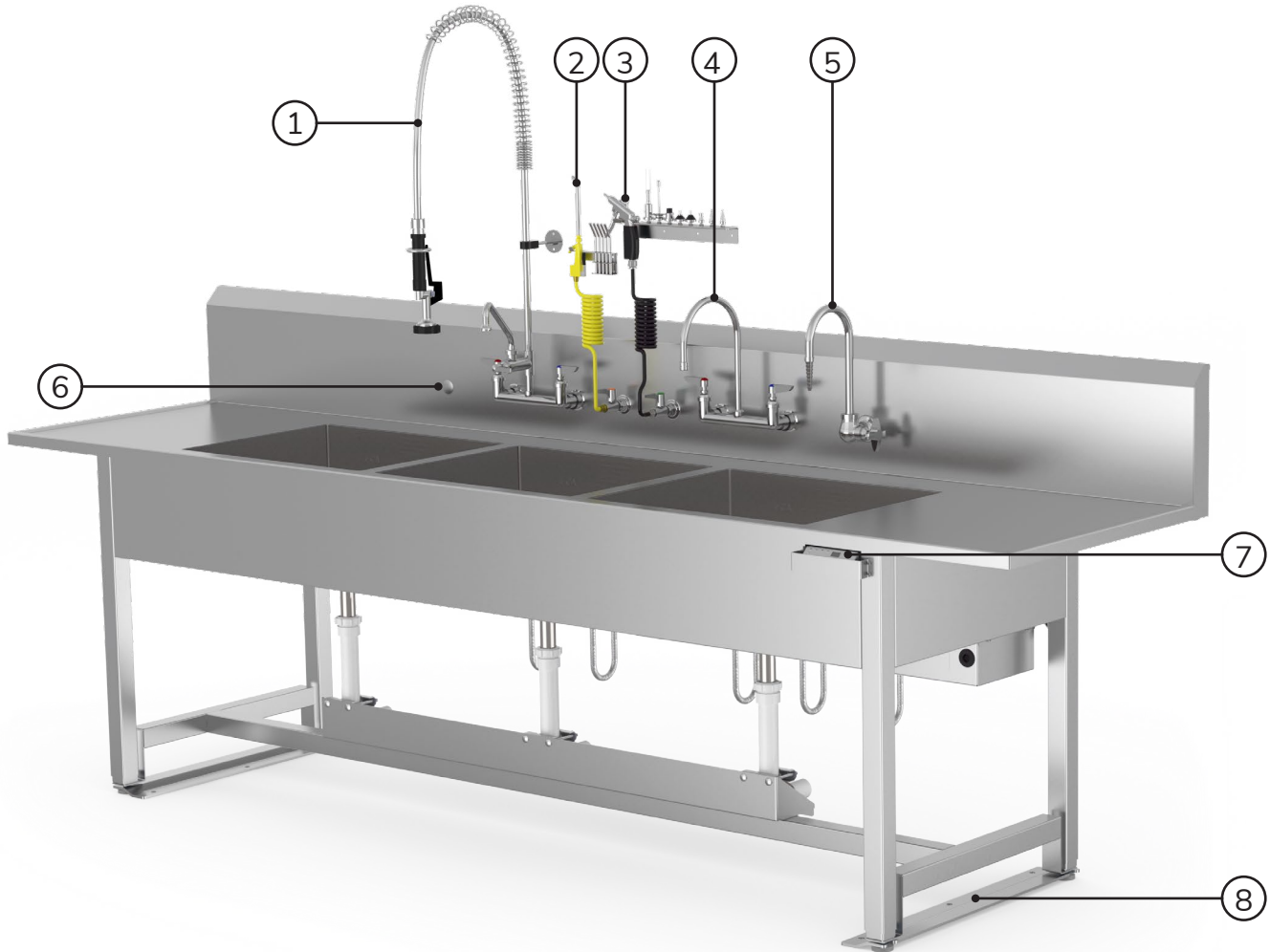

Item #	Part #	Description
1	#PSKT-01	Pre-Rinse Hot/Cold Water Faucet Assembly
2	#PSKT-04	Air Gun Kit
3	#PSKT-05	Water Gun Kit
4	#PSKT-02	Water Faucet
5	#PSKT-03	DI Water Faucet
6	#H0215-05	Backsplash Hole Cap
7	#PCB-001-ASM	PCB Enclosure Assembly (Adjustable Height Sinks Only)
8	#150464	Floor Anchor for 30" Sink

## Unpacking and Inspection Instructions



CAUTION: Processing sinks are heavy and it is recommended that at least two people assist with the unpacking.

### Inspection

1. Receiving area must meet all State and Local regulations prior to unpacking.
2. Customer must inspect skid, frame and sink before and after unpacking to determine if any items were damaged during shipping. If the skid, frame or sink appear damaged in any way, contact the shipping company immediately. Save all damaged packing material.
3. All damaged items must be listed on the Bill of Lading.
4. Customer is responsible for the proper disposal of all packing materials. The disposal of these items must meet all State and Local regulations.

### Unpacking Processing Sinks

Stainless steel Processing Sinks are shipped on well-constructed wooden skids with a wooden frame structure. Steel bands secure the sink to the skid. The stainless steel surfaces of the sink are protected by layers of plastic wrapping.

IMPORTANT: Wear gloves and eyewear during the unpacking operation.



Caution! Do not use a box cutter or any other cutting utensil to remove the plastic wrapping around the sink. These items can scratch the protective coating on the stainless steel allowing the surface to rust.

1. Use tin snips to cut the metal bands holding the sink to the wooden skid.
2. Remove the wooden framework.
3. Remove the plastic protective wrapping.



Carefully inspect Processing Sink while unpacking. If it appears damaged or defective in any way, call your ACART representative.

Retain all shipping materials until the sink is completely unpacked and inspected for damage.



## Sink Installation Steps

Below is an overview of the sink installation steps. Details for the installation of the various parts will be covered in subsequent pages.

1. For adjustable height sinks, ensure that a 120V GFI outlet is accessible where the sink will be located.
2.  **DO NOT** plug the sink power unit in at this time.
3. Assemble and install the backsplash mounted accessories (pre-rinse gooseneck combo faucet, DI water faucet, gooseneck water faucet, and Air/Water Gun - If applicable) **BEFORE** moving the sink to its desired location. It will be necessary to be able to access the back of the sink for this operation.
4. Install lower shelf, pegboard back frame, and back frame accessories. (if applicable)
5. With the help of an assistant(s), move the sink into the desired location. Ensure that the sink is not positioned so that it is difficult to disconnect power to the sink if needed. For Adjustable Height sinks, It is recommended to have 7/8 in gap around sink.
6. Level the sink by adjusting the feet levelers on the sink legs.
7. For all sinks, attach floor anchors and bolt sink feet to the floor. Use appropriate hardware for floor material type (supplied by others).
8. For fixed height sinks, install the basin drain(s) piping (supplied by others).
9. Connect basin drain to existing floor or wall drain in accordance with applicable local code standards.
10. Connect hot and cold water lines to the existing hot and cold inlet water lines in accordance with applicable local code standards.
11. Connect the DI (normal or treated water) water line to the DI water faucet in accordance with applicable local code standards.
12. Connect the Air Gun to existing pressure-regulated air line in accordance with applicable local code standards.
13. Assemble and install mounts to secure pre-rinse faucet and water/air gun to wall/pegboard.
14. For Adjustable Height sinks, plug power cord into 120V GFI outlet and program memory control pad.
  -  If power cord is lost or damaged, replace with equally rated power cord. An inadequate power cord could cause injury.

### Sink Placement Requirements

#### Power Source:

Adjustable Height processing sinks require a power source to operate the hydraulics system. Place the sink so that its right side (where its power unit is located) is near a 120 VAC GFCI power outlet. A 9ft power cord is provided.



Note: All power connections must be completed per local codes.

Fixed Height sinks do not need a power source.

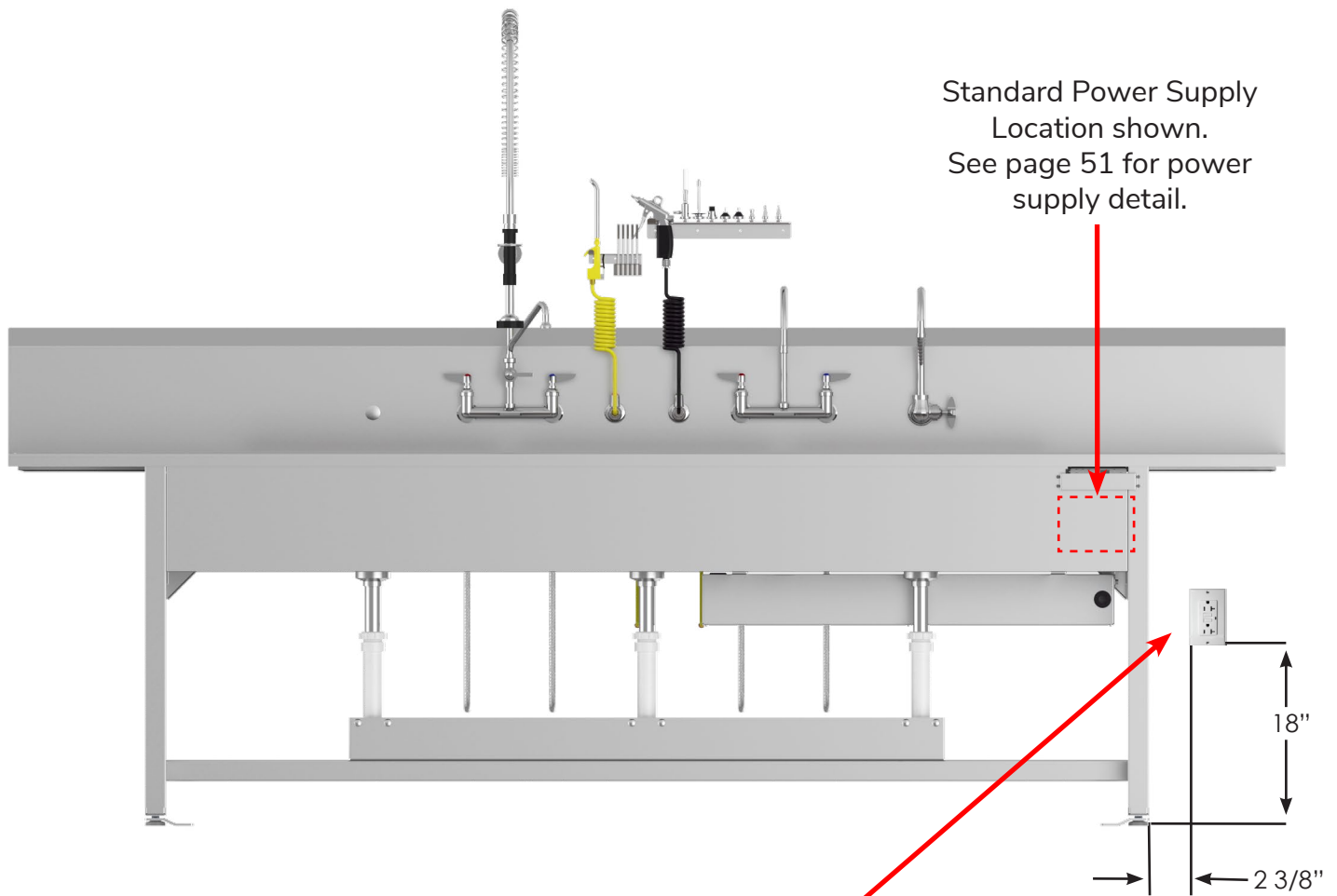

Standard Power Supply Location shown. See page 51 for power supply detail.

This illustration shows a suggested power location.

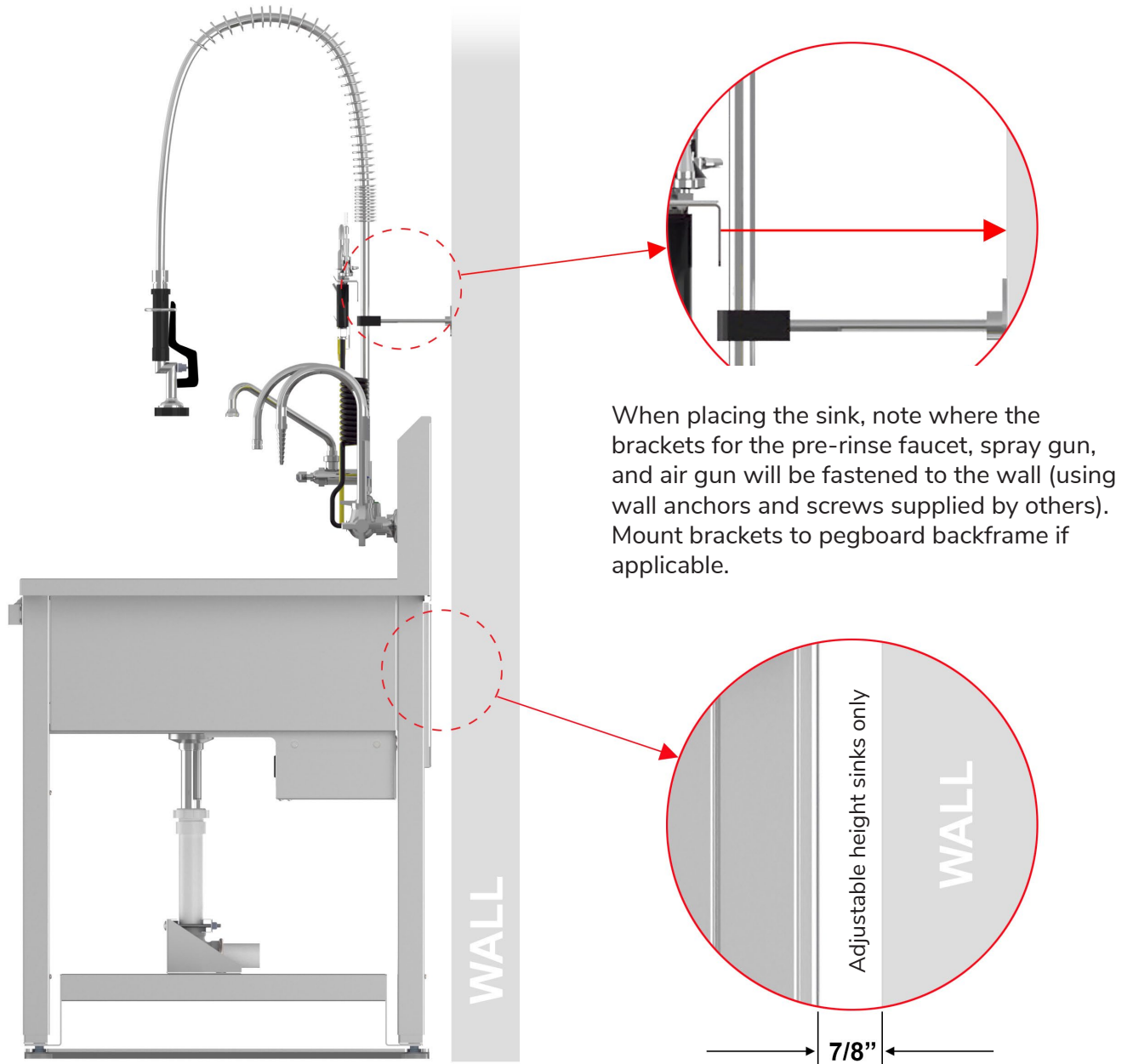

Adjustable height sinks only - for proper sink placement, a minimum distance spacing of 7/8" is required between the sink back and sides to the wall.

(For clarity, spacing shown in this illustration is exaggerated.)

### Install Pegboard Backframe

With the help of an assistant, raise pegboard backframe into position.

1. Insert the two install assist clips into the bottom two slots of each side of the backframe.

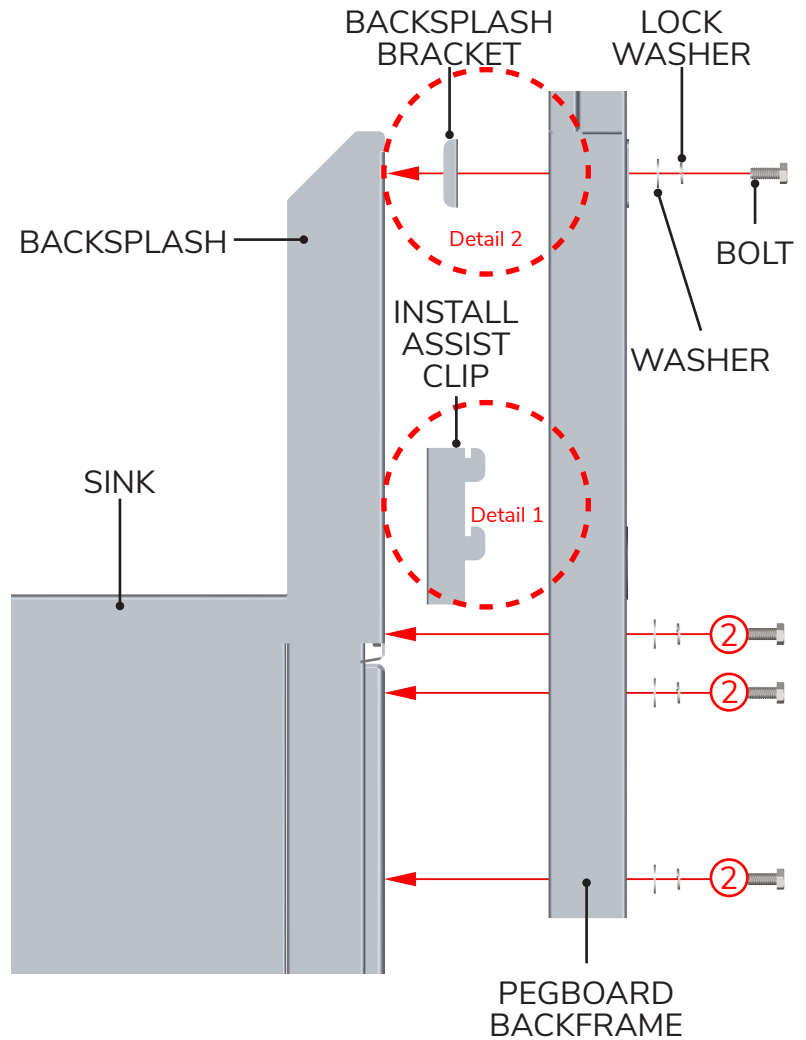
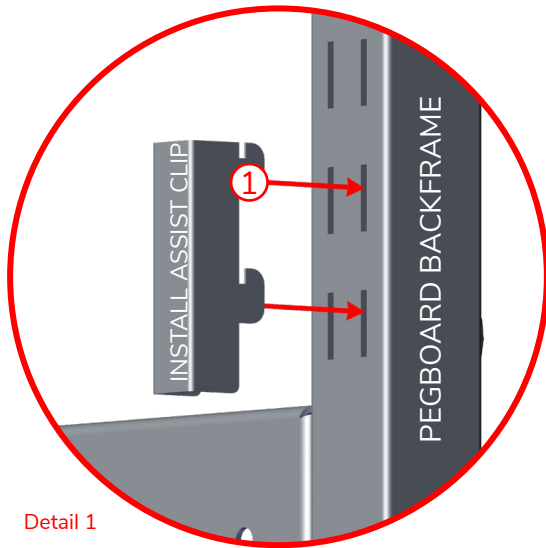

2. Rest entire backframe, with install assist clips, on top of frame under backsplash. Align bolt holes and install all bolts as shown (first through lock washer, then through washer). Tighten securely.
3. Install backsplash bracket (shown in blue) upward and under backsplash lip (make sure bracket is vertical, as shown).
4. Align bolt holes and install all bolts as shown (first through lock washer, then through washer, then into nut in backsplash bracket). Tighten securely.

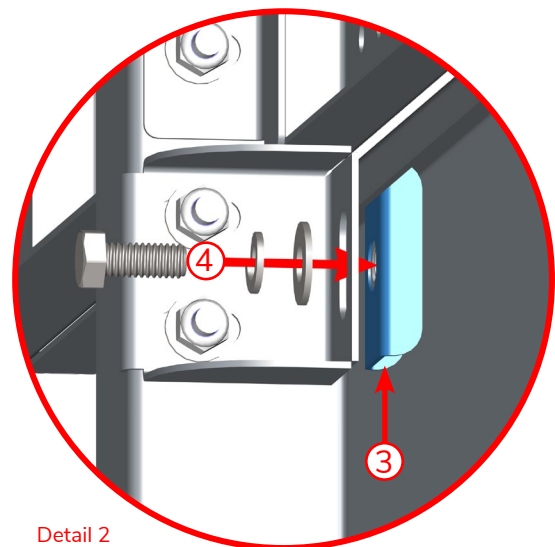

(ALL bolt locations shown on page 17)

### Outer Backframe Bracket Install (where applicable)

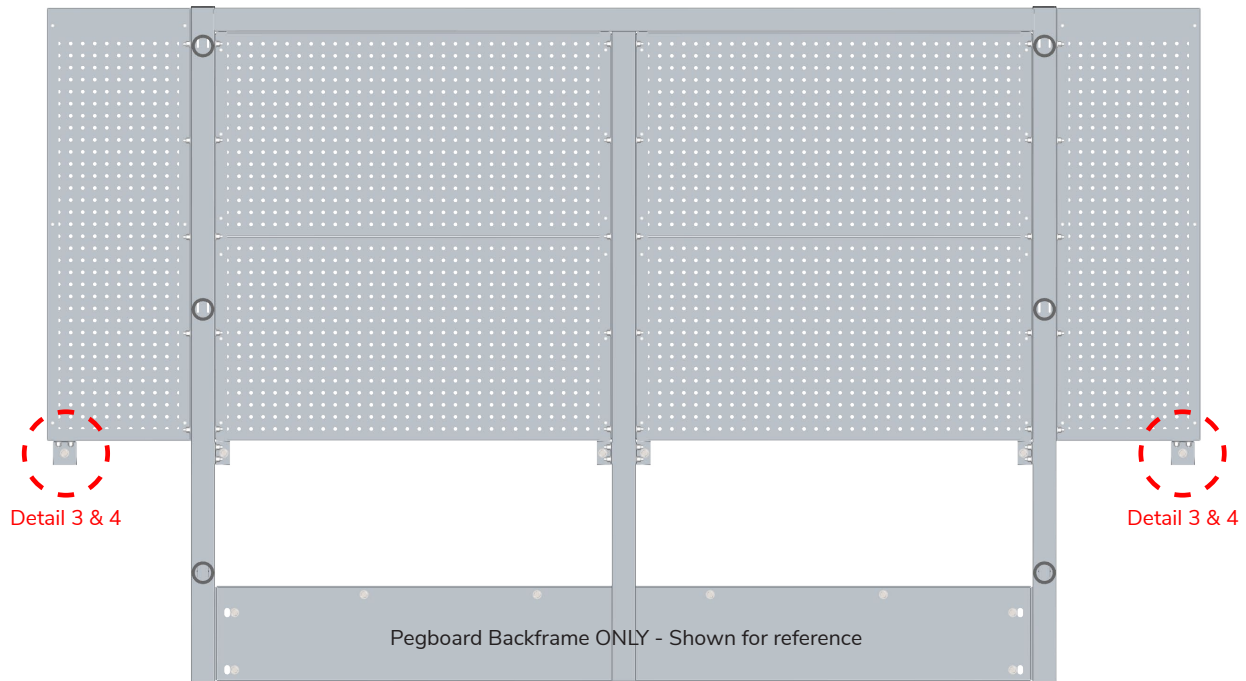

5. Install backframe bracket (shown in blue in Detail 3) upward into place.
6. Align bolt holes and install bolts as shown in Detail 3 (first through washer, then holes, then washer, then into lock nut). Tighten securely.

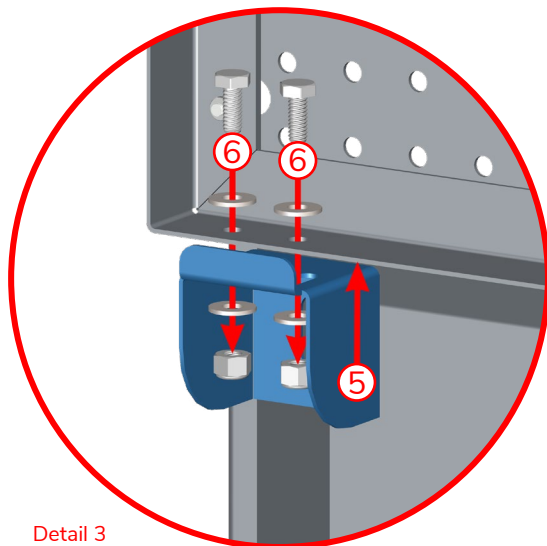

Detail 3

7. Install backsplash bracket (shown in blue in Detail 4) upward and under backsplash lip (make sure bracket is vertical, as shown).
8. Align bolt holes and install bolts as shown in Detail 4 (first through lock washer, then washer, then into backsplash bracket nut). Tighten securely.

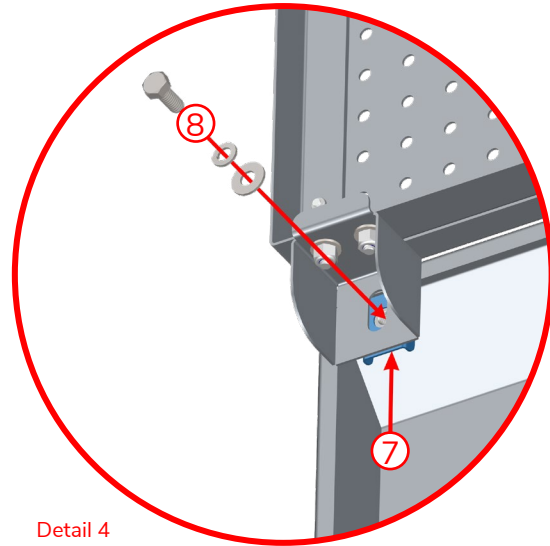

Detail 4



### Bolt Locations and Wire Management

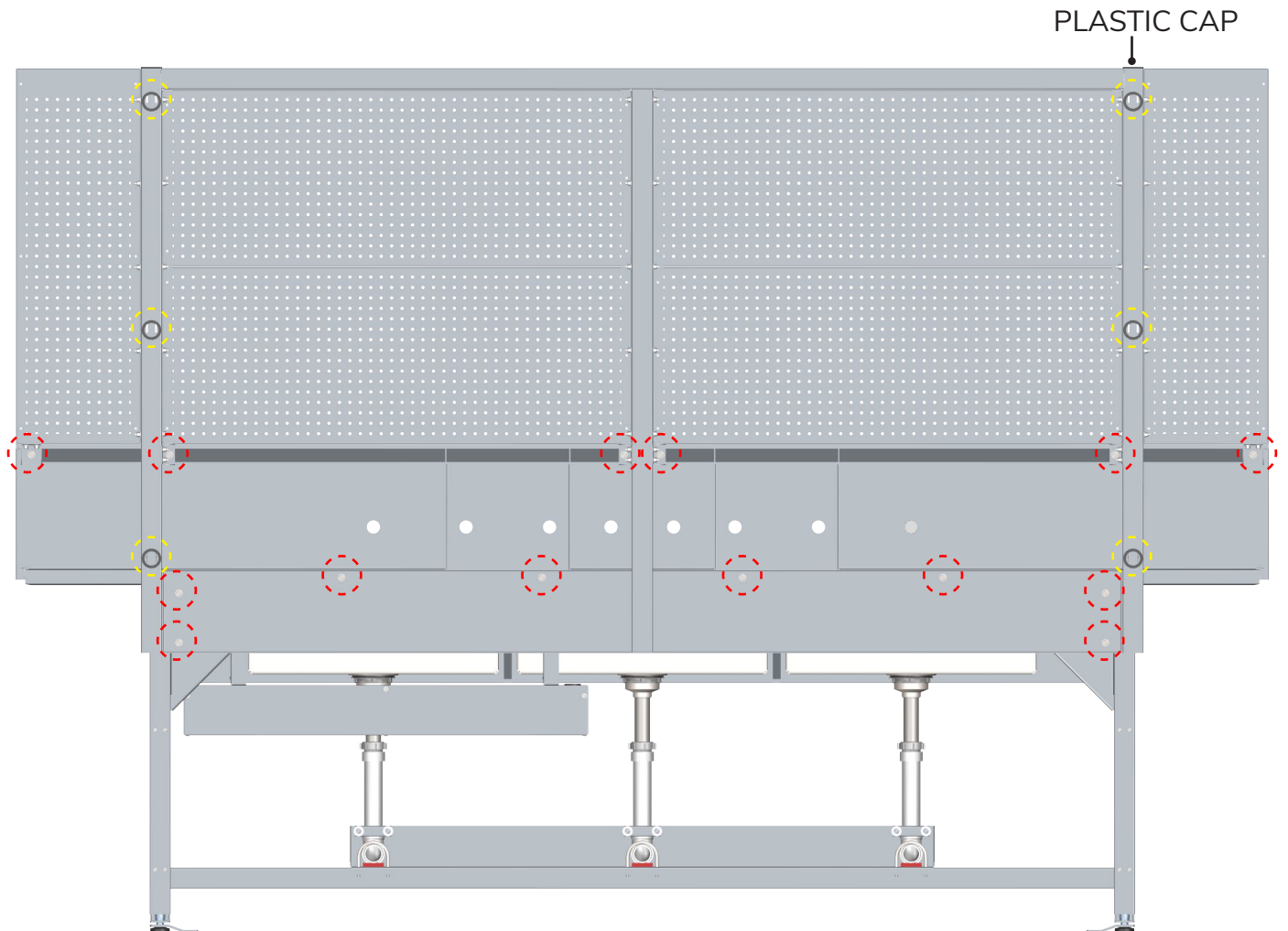

Red circles represent bolt locations on triple basin sink.

Yellow circles represent grommet hole locations on triple basin sink.

### Wire Management

For pegboard backframe electronic accessories, wires can be run through:

- A. The top of the frame by removing the plastic cap on the top or drilling a hole in the plastic cap then run down through frame.
- B. Grommet hole locations (shown above in Yellow) then run down through frame.

### Assemble and Install Pre-Rinse Water Faucet (MMKL53-1000-AF2)

The Pre-Rinse Faucet comes as a kit. General Instructions for assembly and installation are:

Turn off water supply at the main source.

Hand-tighten all parts prior to tightening with a wrench.

Do not force parts together.

All plated surfaces should be handled with care. Avoid scratching with tools.

Use teflon tape when making threaded connections to water supply lines.

#### STEP #1 - Base Faucet Assembly (MM-KL53-Y001)

Install base faucet body as shown.

1. Insert faucet body through front holes in sink backsplash to water faucet backsplash plumbing kit, then tighten coupling nut.
2. Tighten flange against back of sink backsplash.

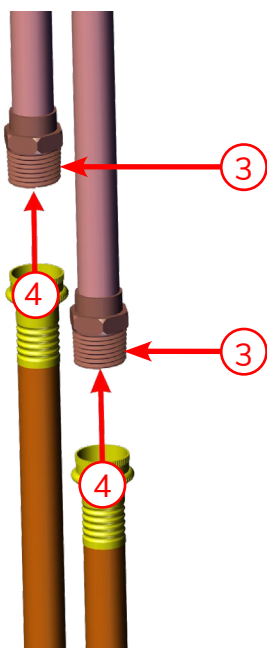
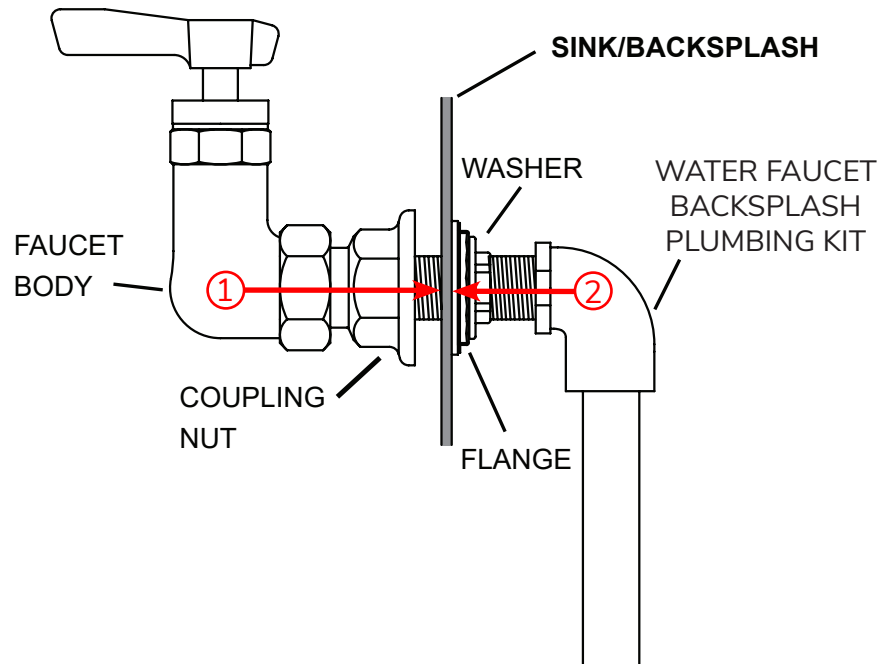

3. Apply teflon tape to pipe threads.
4. Attach flex hoses to lower threaded pipes.

**IMPORTANT - DO NOT continue with Steps 2-5 until sink is moved to it's permanent location.**

### STEP #2 - Installation of the Add-on Faucet

5. Apply teflon tape to threads on end of short riser pipe attached to add-on faucet.
6. Thread short riser pipe into faucet body and tighten.
7. Thread riser pipe (Do NOT apply Teflon tape yet) into add-on faucet body temporarily and hand tighten .

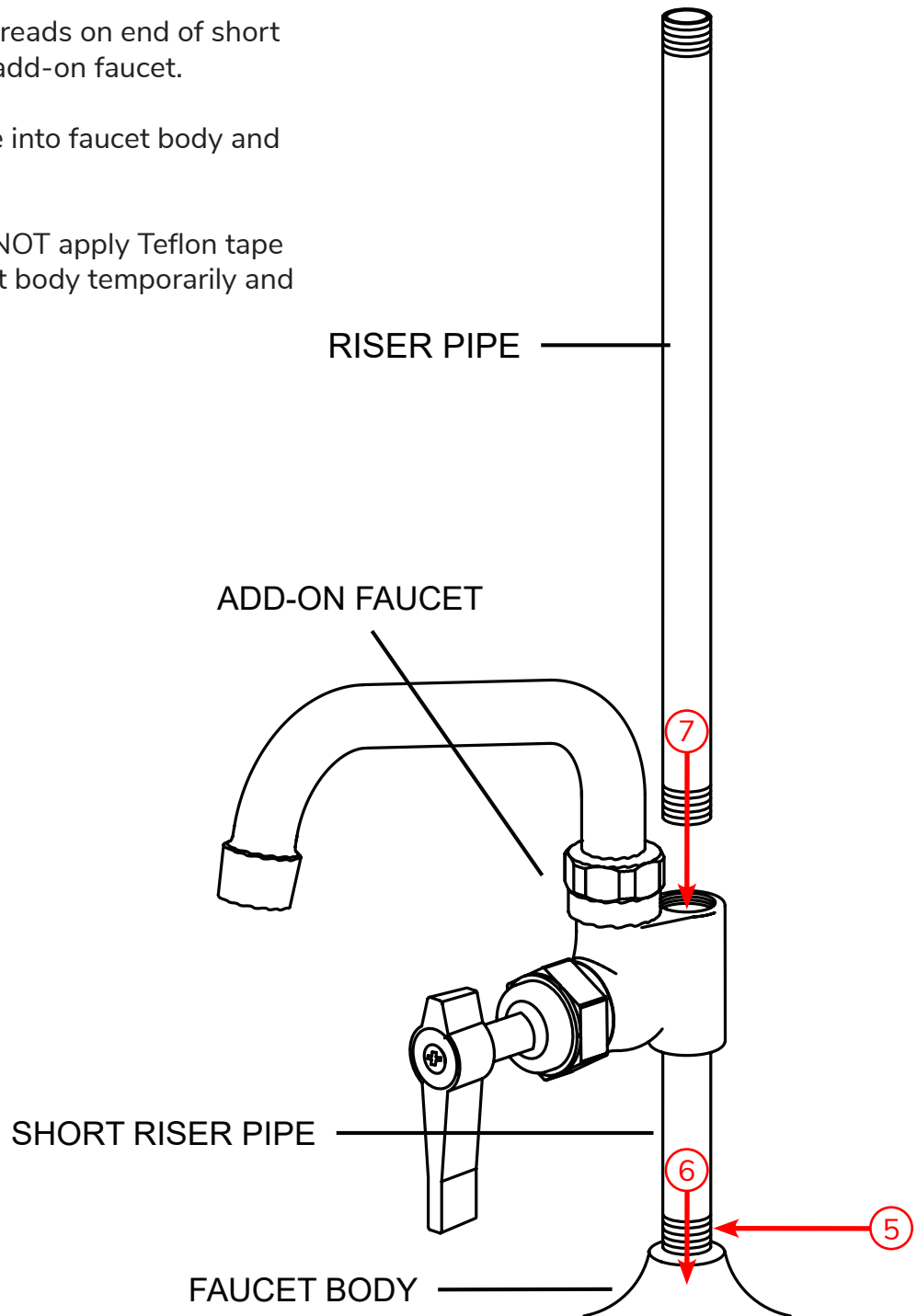

### STEP #3 - Assemble and Install Wall Bracket

8. Screw off to remove pre-installed bracket from support rod.

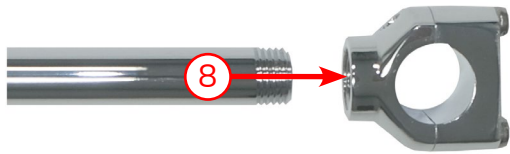

9. Determine correct length of support rod from wall to riser pipe. Cut rod to approximate size with appropriate tool.

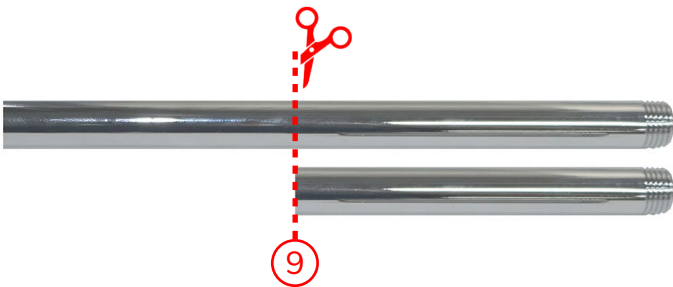

10. Screw on to install NEW black bracket (supplied) onto support rod.

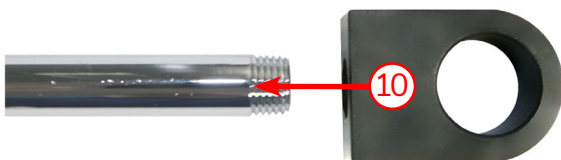

11. Determine position of wall bracket base (wall bracket base is mounted 12" from top of backsplash with sink at it's lowest position and centered to riser pipe)

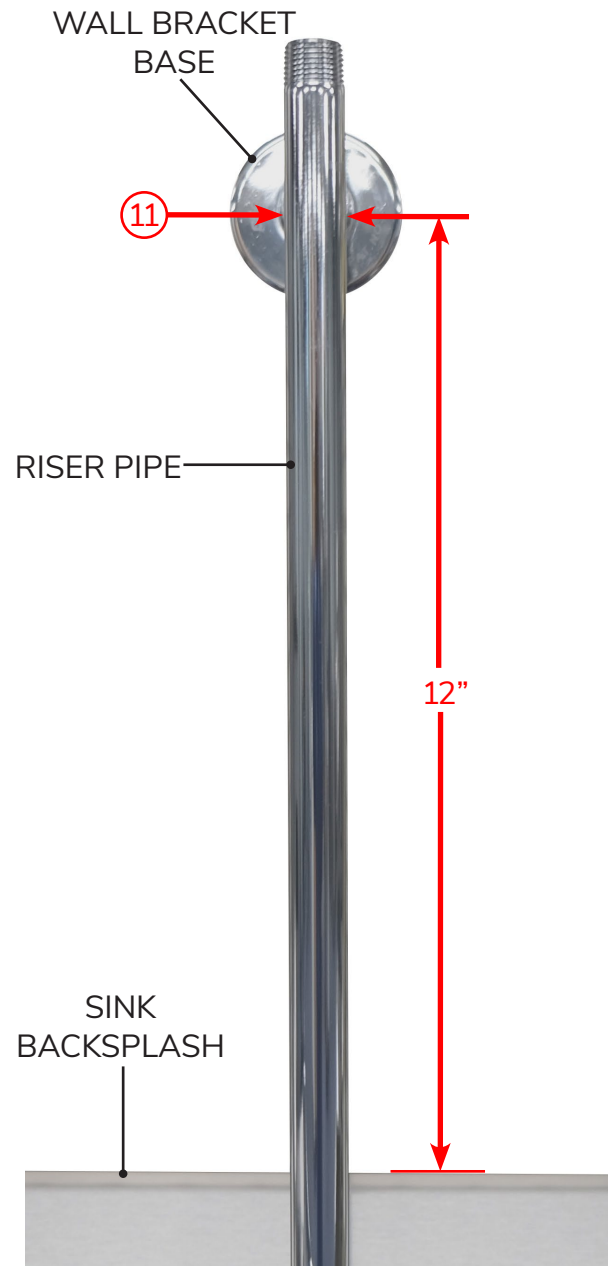

### STEP #3 - Assemble and Install Wall Bracket (continued)

12. Unscrew and remove riser pipe from add-on faucet body.

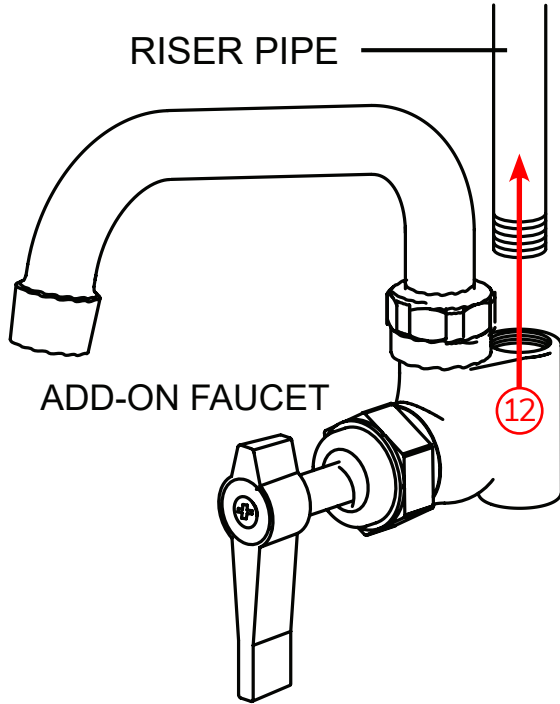

13. Affix wall bracket base securely to wall at position determined at step 11.

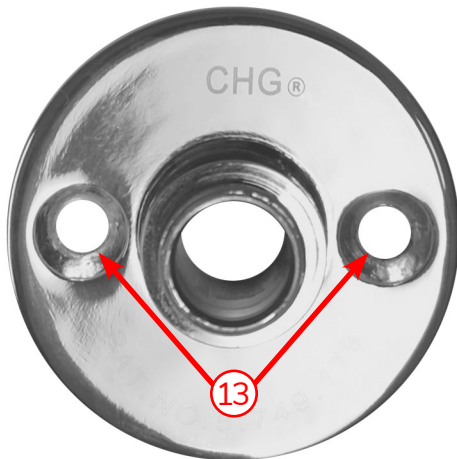

14. Install compression nut and bracket ferrule and tighten securely.

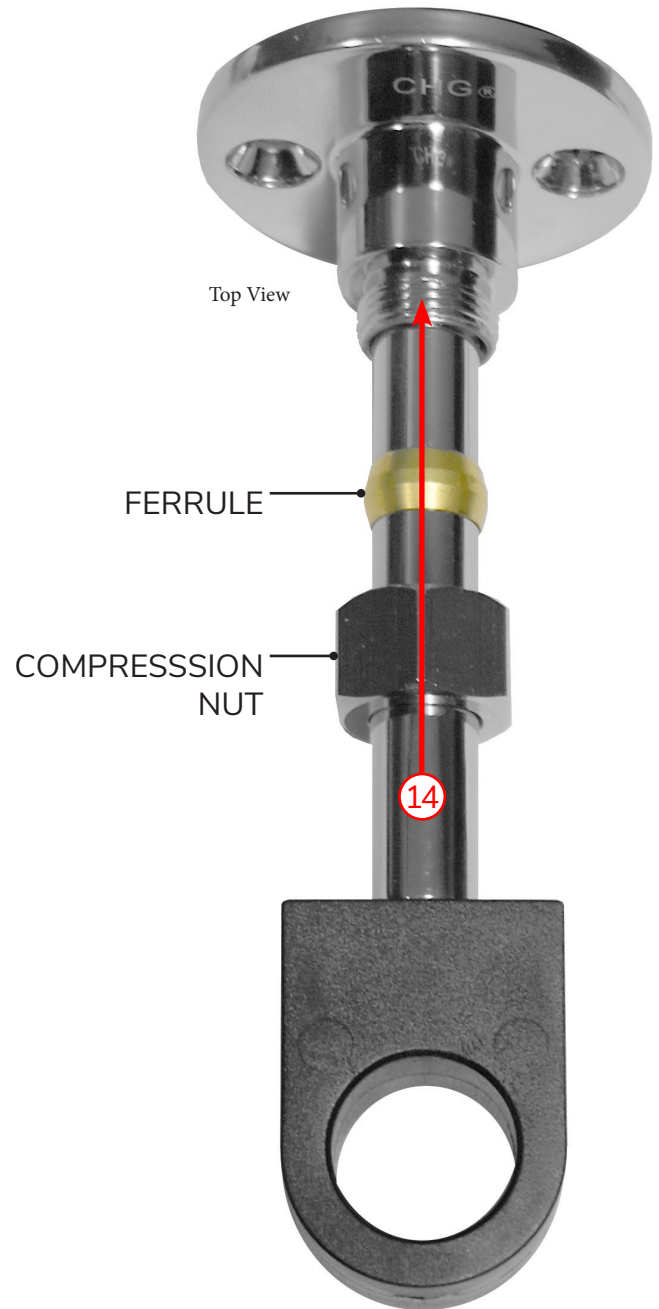

### STEP #3 - Assemble and Install Wall Bracket (continued)

15. Apply teflon tape to threads on both ends of riser pipe.
16. Slide riser pipe through wall bracket assembly then thread into add-on faucet body and hand tighten.

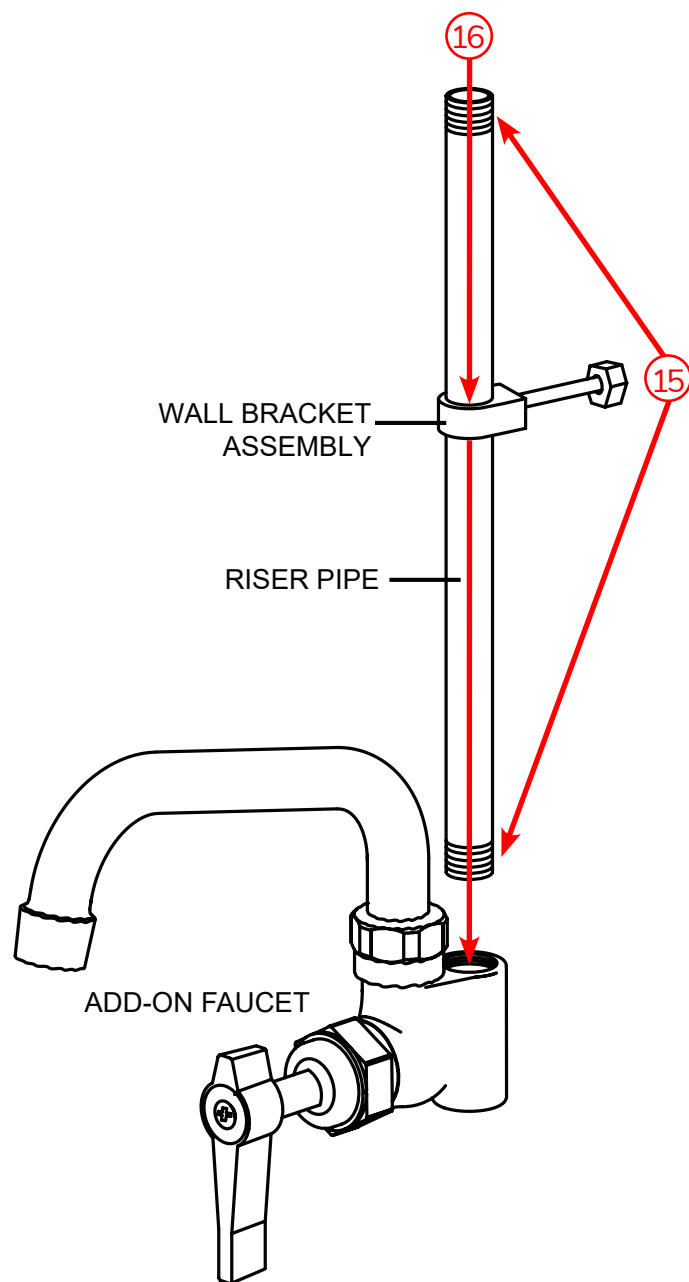

### STEP #4 - Assemble Spray Head Hook to Riser

17. Spread (open) clamp section of hook so that it will slide over riser without marking finish of riser.
18. Orient spray head hook with hook up and assemble to riser. Place 1/2" from thread on riser.

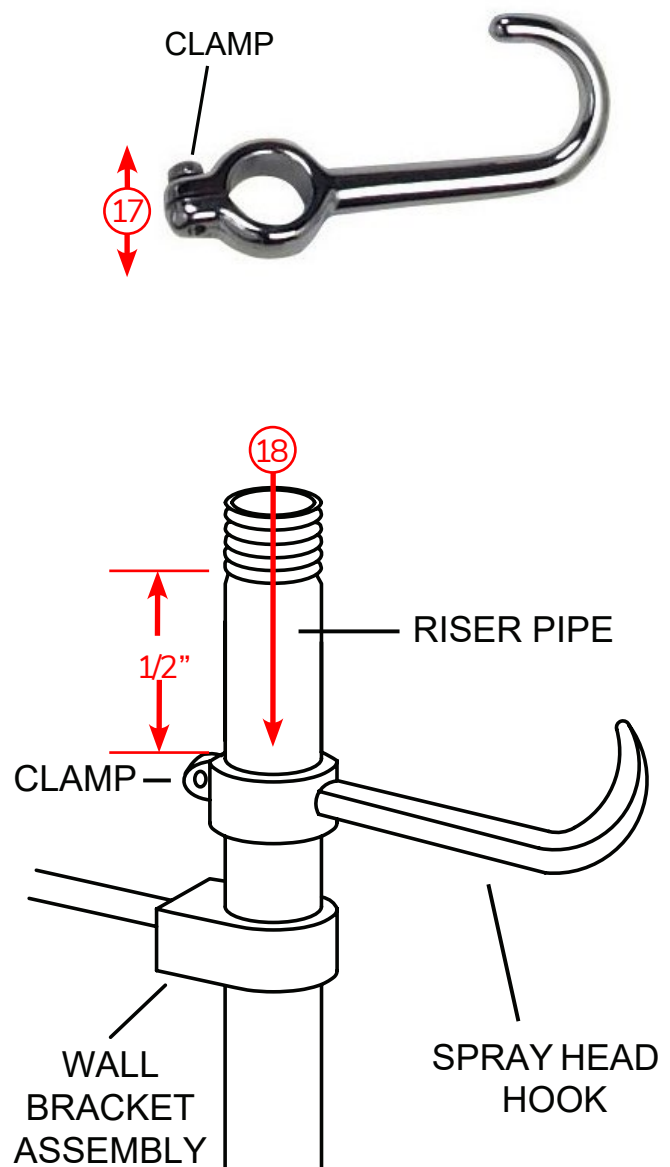

### STEP #5 - Assemble Pre-rinse with Gooseneck Spring

19. Assemble Spring Retainer to Riser Pipe and tighten with wrench. This will also tighten the Riser Pipe on the faucet body.
20. Assemble Hose to spring retainer. Ensure the O-ring is in place inside of the hose coupling prior to assembly. (Additional O-rings are provided for future use.) Tighten securely.
21. Assemble Large Coil Spring over Hose and onto Spring Retainer.  
**IMPORTANT:** Spring must be assembled vertically with large curve of spring to the top.
22. Assemble Spray Head Ring over Spray Head Grip, and assemble Spray Head Assembly to the Hose and tighten with wrench. Ensure that O-ring is in place prior to assembly.

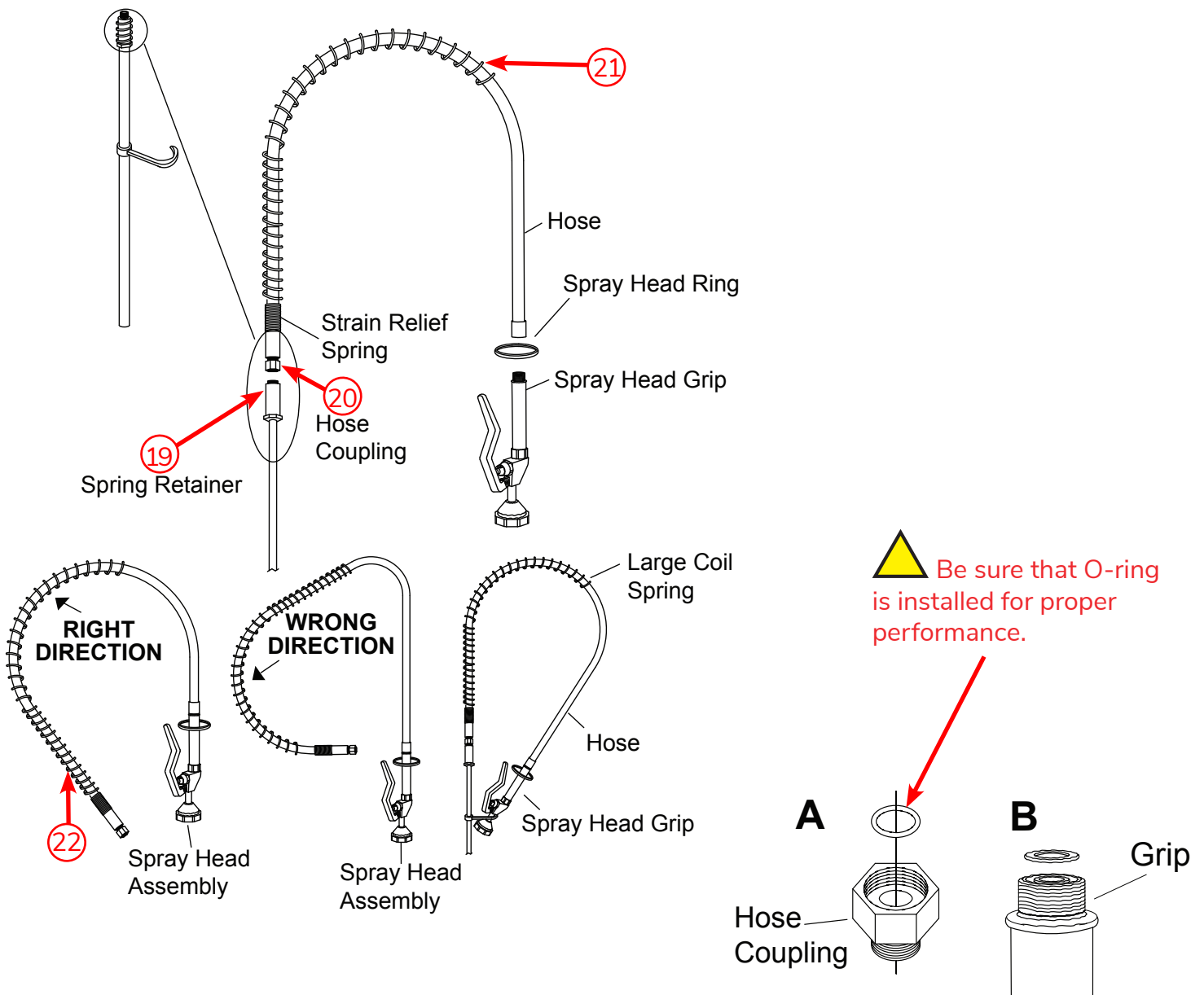

### Operation and Maintenance of the Pre-Rinse Spray Faucet

To operate the Pre-Rinse Spray Faucet -

- Release the spray head lever and grip from the spray head ring.
- Turn on the hot/cold water.
- Squeeze the lever to run the water, or for constant running water, slip the spray head ring over the depressed lever.

When finished -

- Turn off the hot/cold water.
- Reattach the spray head ring to the lever and grip.
- Hook the spray head to the riser pipe hook.

#### Cleaning Instructions

When cleaning the pre-rinse spray faucet DO NOT use abrasive or chemical cleaners, as they can damage the surface. Use only mild soap and water and wipe dry with a clean towel or cloth.

When cleaning surrounding surfaces with chemical cleaners, be cautious of splattering in order to prolong the life and finish of the pre-rinse spray faucet fixture.



### Replaceable Pre-Rinse Water Faucet Parts

The Pre-Rinse Hot/Cold Water Faucet (H0134-10)

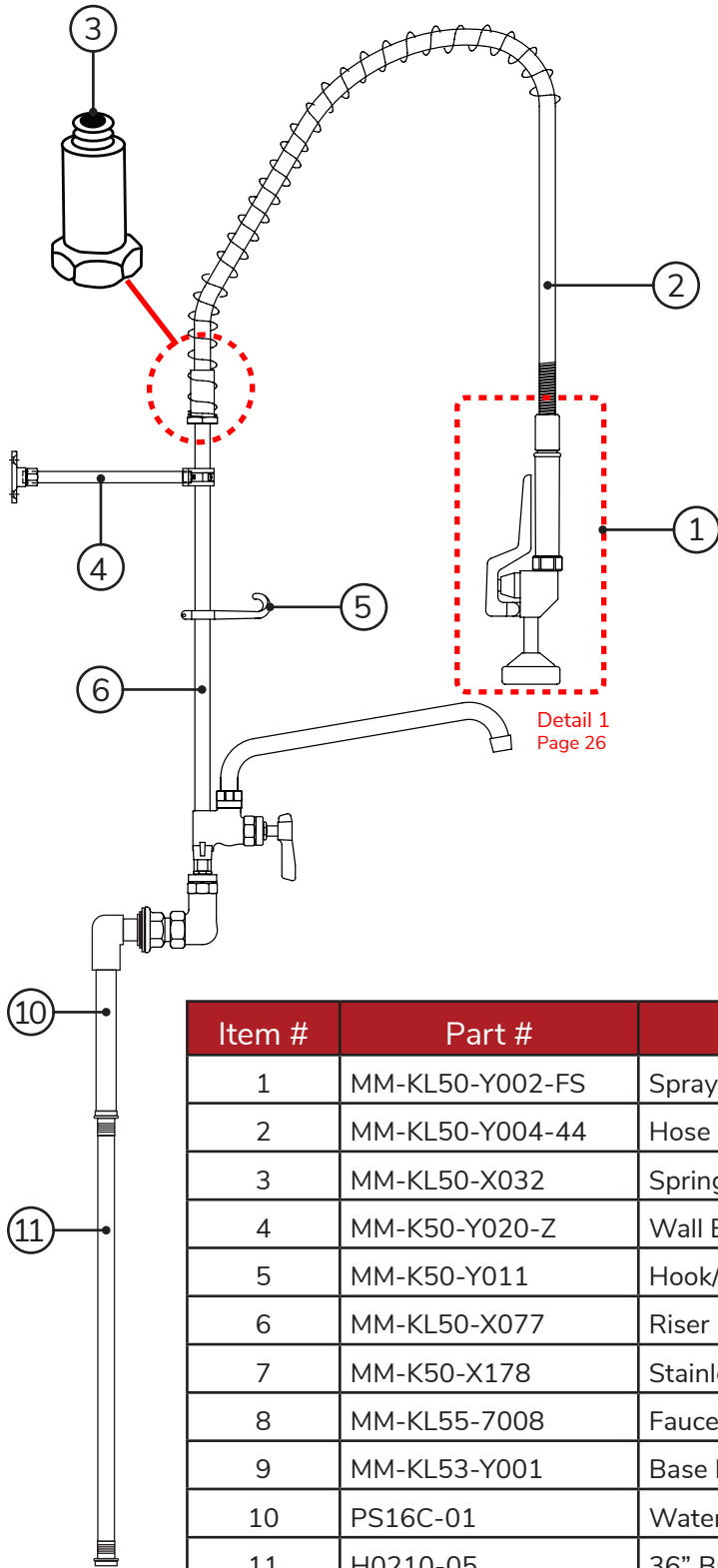

Item #	Part #	Description
1	MM-KL50-Y002-FS	Spray Head Assembly (see Detail 1)
2	MM-KL50-Y004-44	Hose Assembly with Grip (44" LG)
3	MM-KL50-X032	Spring Retainer
4	MM-K50-Y020-Z	Wall Bracket Assembly
5	MM-K50-Y011	Hook/Screw Assembly
6	MM-KL50-X077	Riser Pipe, 18"
7	MM-K50-X178	Stainless Steel Spring
8	MM-KL55-7008	Faucet Body, Add-on Faucet
9	MM-KL53-Y001	Base Faucet Assembly, Double Pantry (see Detail 2)
10	PS16C-01	Water Faucet Backsplash Plumbing Kit
11	H0210-05	36" Braided Flex Hose

### Detail 1 - Spray Head Assembly (MM-KL50-Y002-FS)

The Spray Head comes pre-assembled. The various parts are shown here.

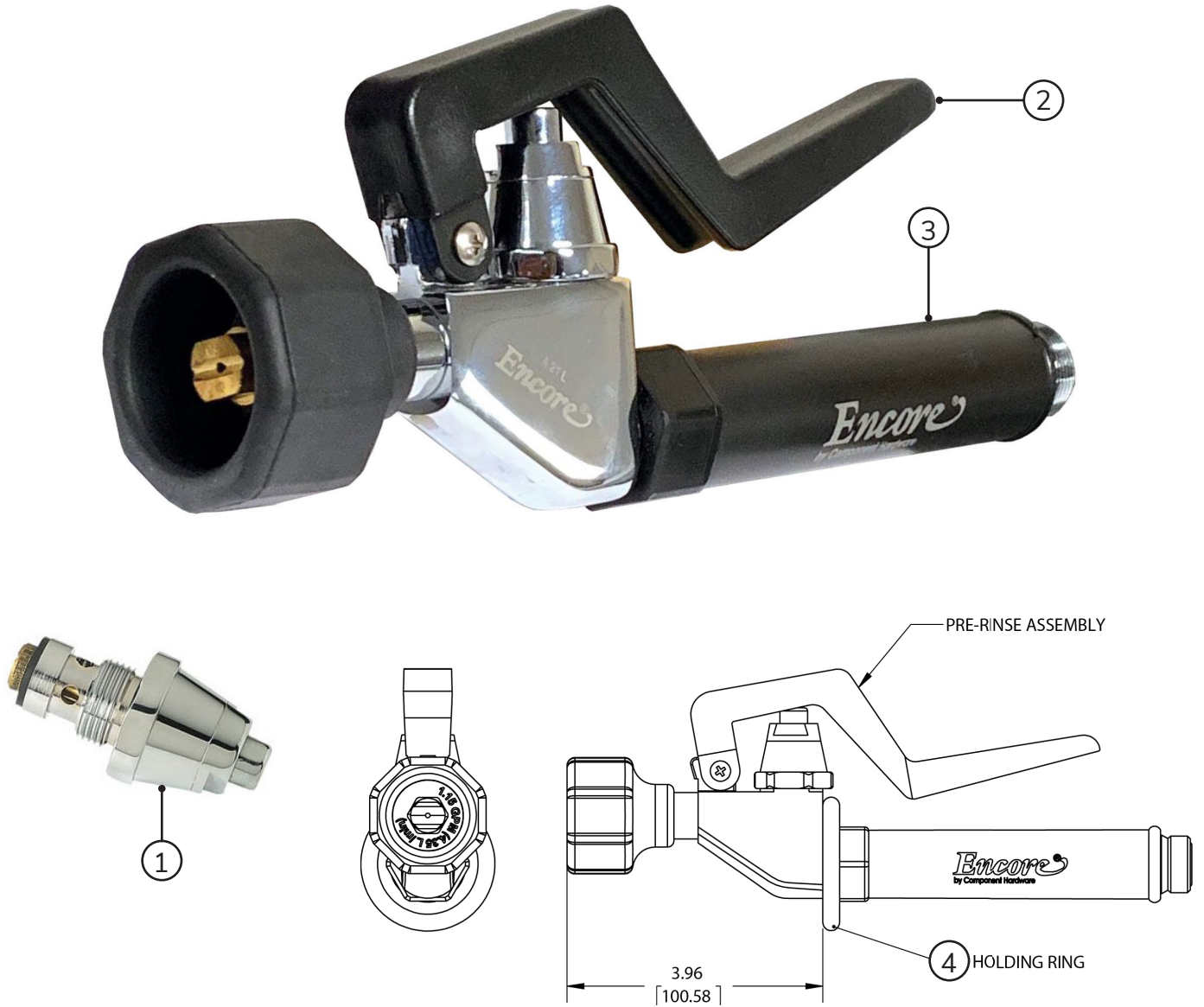

Item #	Part #	Description
1	MM-KL50-Y027	Button Valve Assembly
2	MM-K50-X016-SP	Spray Handle with Screw Assembly
3	MM-KL50-X025	Grip
4	MM-K50-X017	Holding Ring

### Detail 2 - Base Faucet Assembly (MM-KL53-Y001)

In the Pre-Rinse Faucet Assembly, the Base Faucet comes (along with handles and hot/cold valves) pre-assembled. The Hot/Cold Valve Assemblies and the Handle Replacement can be ordered separately. These components are also replacements for MM-KL55-Y001-Z (Add-on Faucet).

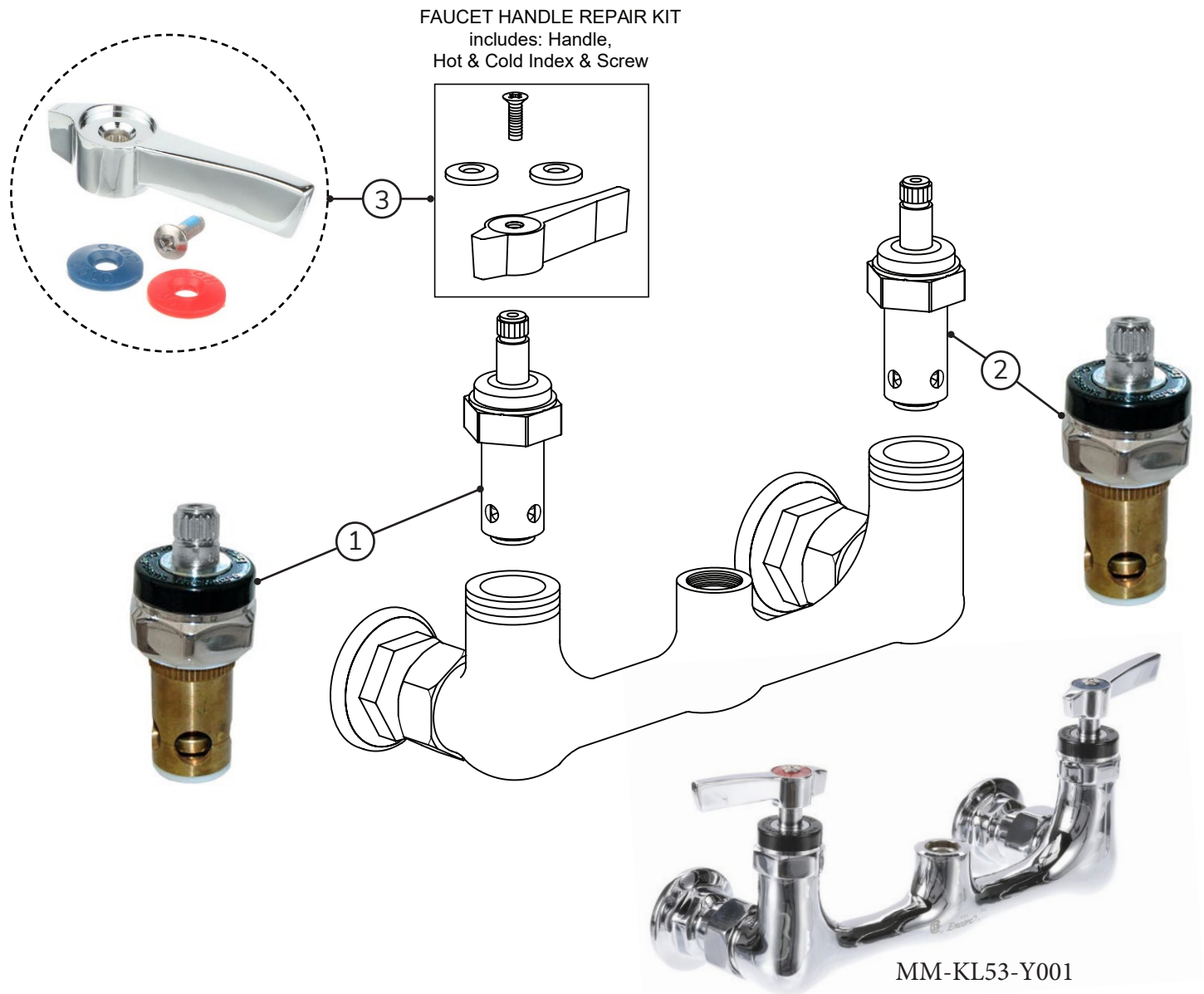

Item #	Part #	Description
1	MM-KL50-Y007	Hot Valve Assembly
2	MM-KL50-Y006	Cold Valve Assembly
3	MM-K50-0110	Handle Replacement Kit

### Assemble and Install Air Gun Kit (PSKT-04)

#### STEP #1 - Air Gun Base Assembly

Install Air Gun Base as shown.

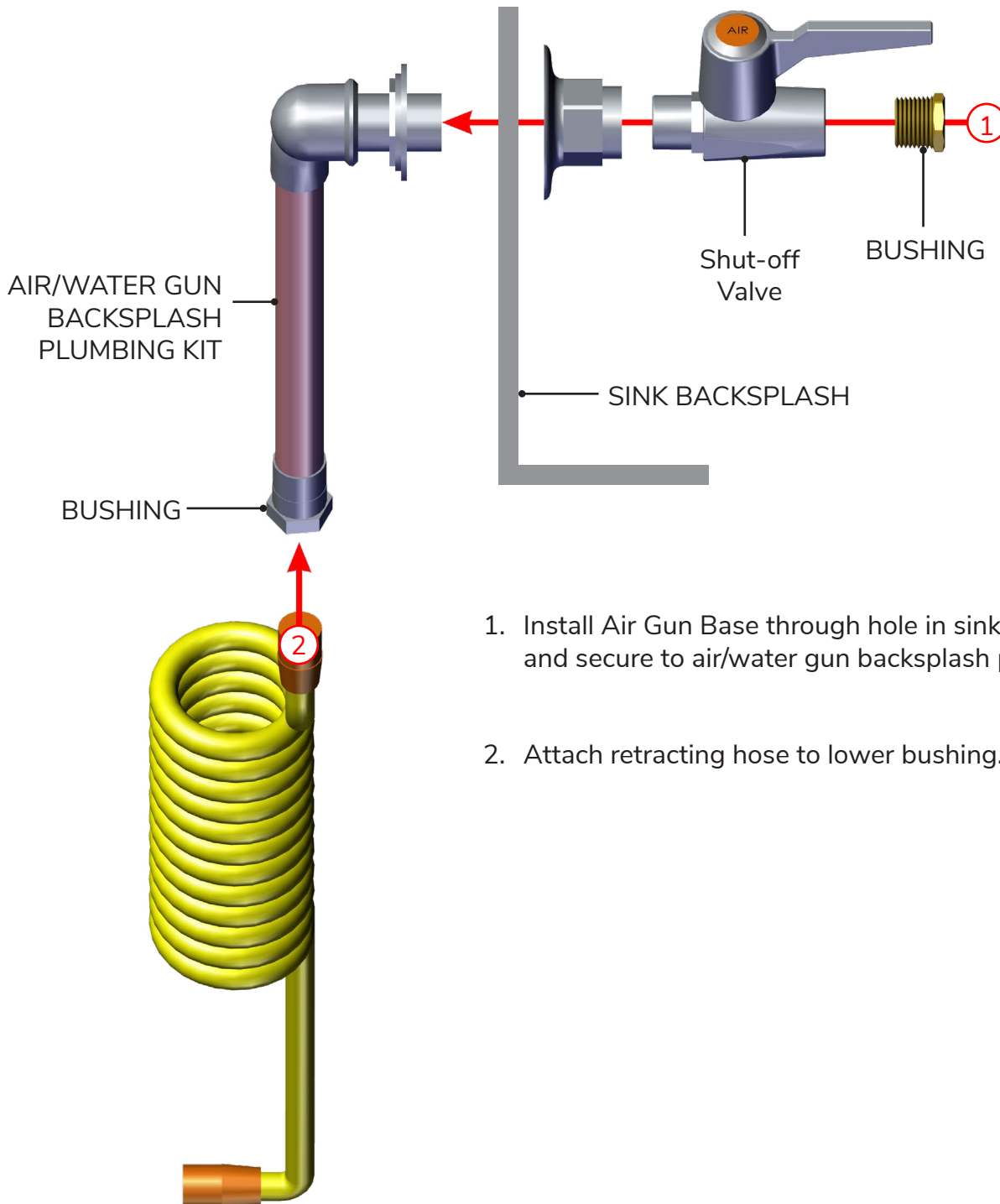

1. Install Air Gun Base through hole in sink backsplash and secure to air/water gun backsplash plumbing kit.
2. Attach retracting hose to lower bushing.

**IMPORTANT - DO NOT continue with Steps 2-3 until sink is moved to it's permanent location.**

### STEP #2 - Attach Upper Hose

3. Attach a hose end into the bushing in the Shut-off Valve.

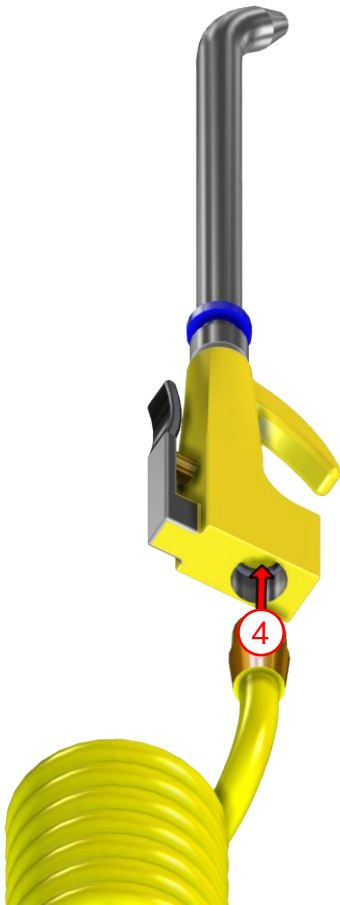
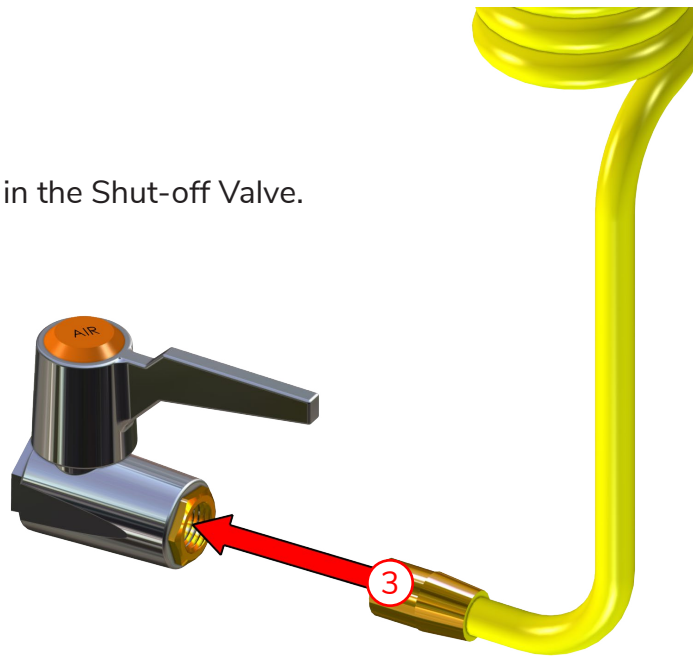

4. Attach the other hose end into the back of the Air Gun.

### STEP #3 - Attach Air Gun Bracket to Wall

Use wall anchors and screws to mount the air gun tip bracket to the wall. Mount bracket 15" from top of backsplash to top of bracket.

Qty needed: 2 screws and 2 anchors for the air gun tip bracket.

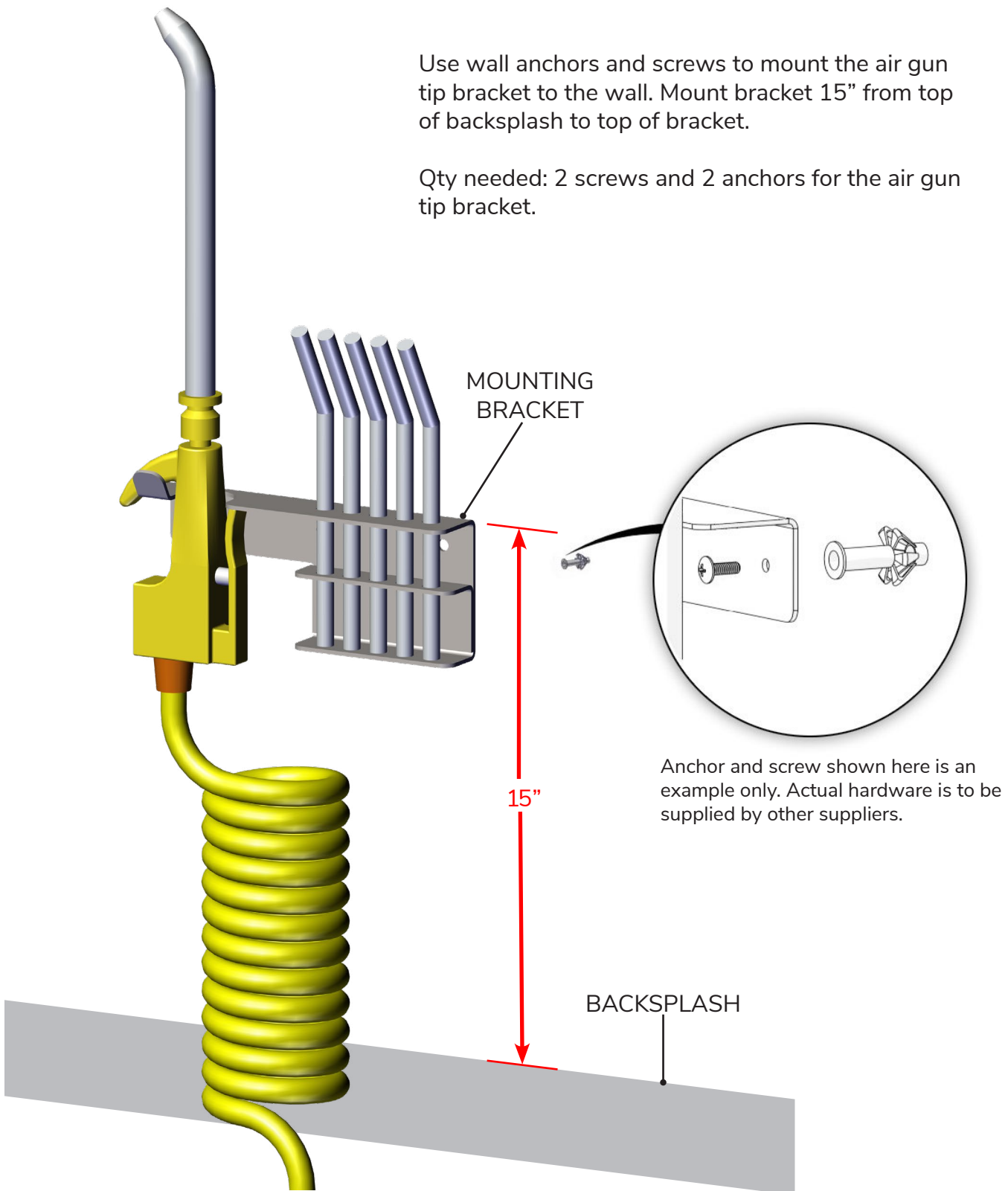

### Air Gun Tips

Five tips come in the kit for use with the air gun. These are:

- High Volume Booster Tip
- Rubber Tip (Maximum usage pressure: 30 PSI)
- Screen Tip
- Star Tip
- Needle Tip (Maximum usage pressure: 30 PSI)

### How to Insert and Remove Gun Tips from the Air Gun

To Insert - Insert single grooved end of tip through the blue ring collar of the air gun until it clicks.

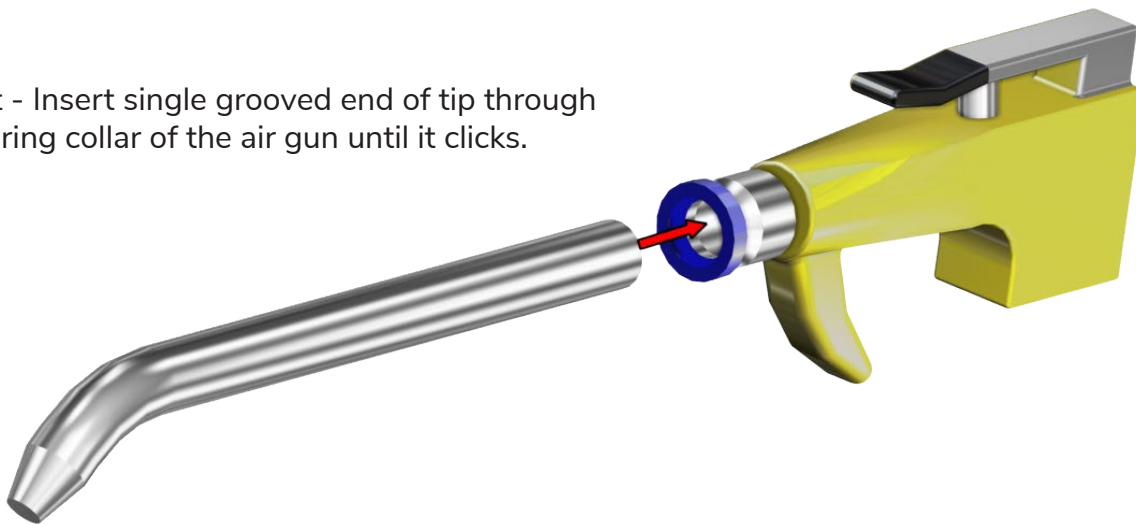

To Remove - Push down the blue ring collar (toward the air gun) to release the tip and pull the tip away from the air gun to remove.

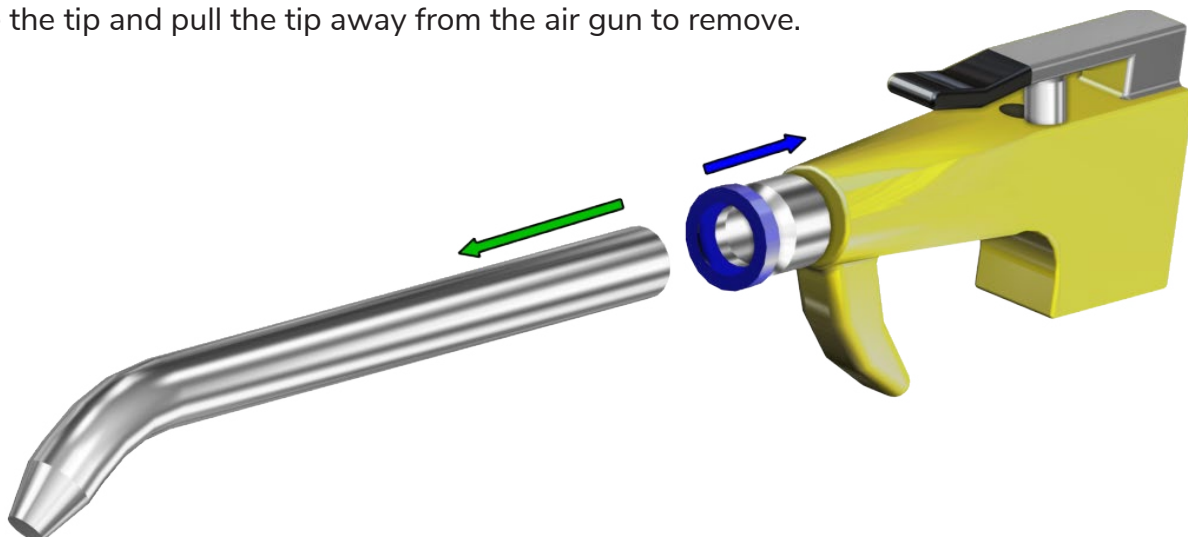

### Replaceable Air Gun Kit Parts

#### Air Gun Kit (PSKT-04)

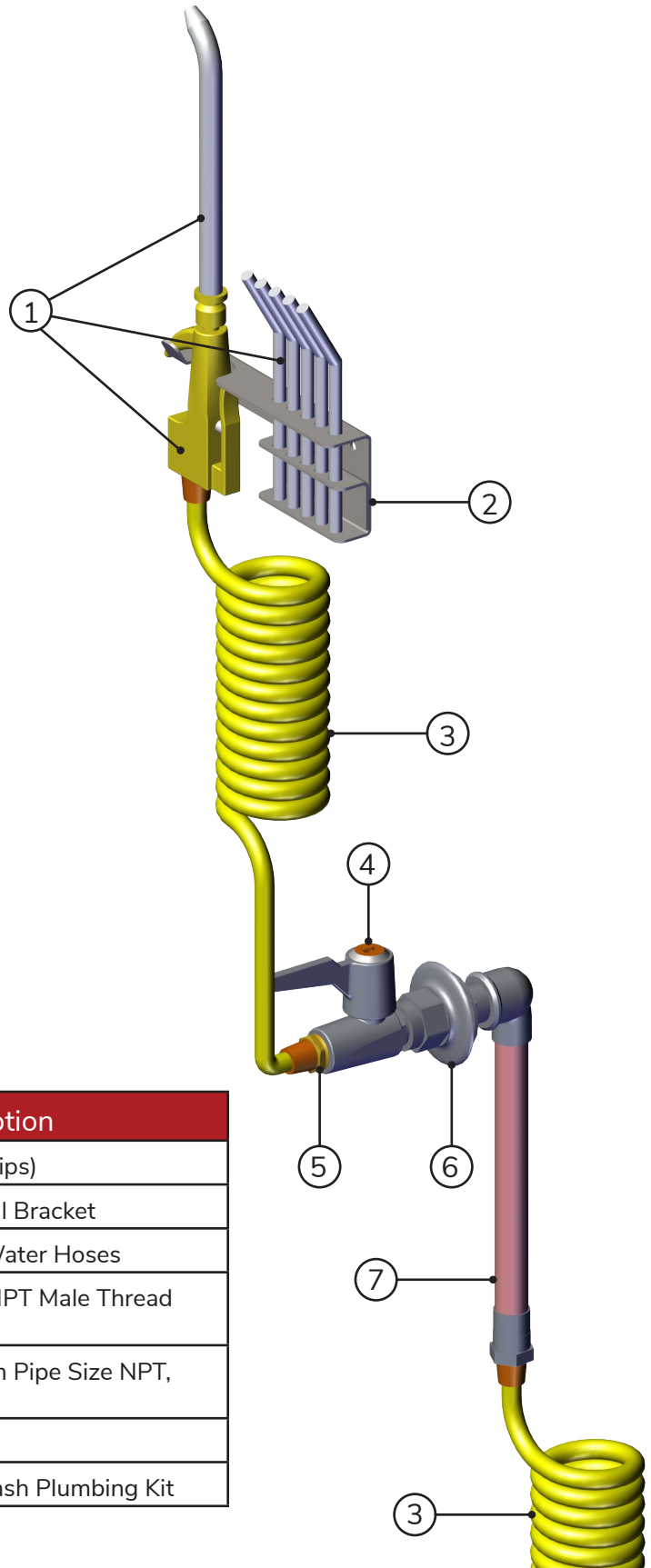

The Air Gun comes in a kit and is for connection to Air lines ONLY. See the parts list below for the contents of the kit.



Item	Part #	Description
1	H0133	Blow Gun with Tips (5 tips)
2	H0600-01	Air Gun Tip Holder/ Wall Bracket
3	H0208-01	Two 8' Retracting Air/Water Hoses
4	H0178-04	Single Ball Valve, 3/8" NPT Male Thread Inlet
5	H0210-02	3/8 Male NPT X 1/4 Fem Pipe Size NPT, Hex Reducing Bushing
6	H0210-21	Flange
7	PS16C-02	Air/Water Gun Backslash Plumbing Kit



## Using and Cleaning the Air Gun Kit

1. Before using, make sure the air gun tip is firmly attached on the gun.
2. Make sure the supply valve (attaching the Air gun to the supply) is open.
3. Operate the air gun by pressing on the trigger lever.
4.  **CAUTION:** Do not point the air gun toward the body. The highly compressed air output can cause severe injury to exposed flesh.
5.  **CAUTION:** The Shut-off Valve should be turned off when not in use.

### Cleaning the Air Gun

Clean surfaces with warm water and a mild detergent. Wipe dry. Remove tip and flush out the air gun by running air through the gun for 30 seconds immediately following cleaning.

## Assemble and Install Water Gun Kit (PSKT-05)

### STEP #1 - Water Gun Base Assembly

Install Water Gun Base on backsplash as shown.

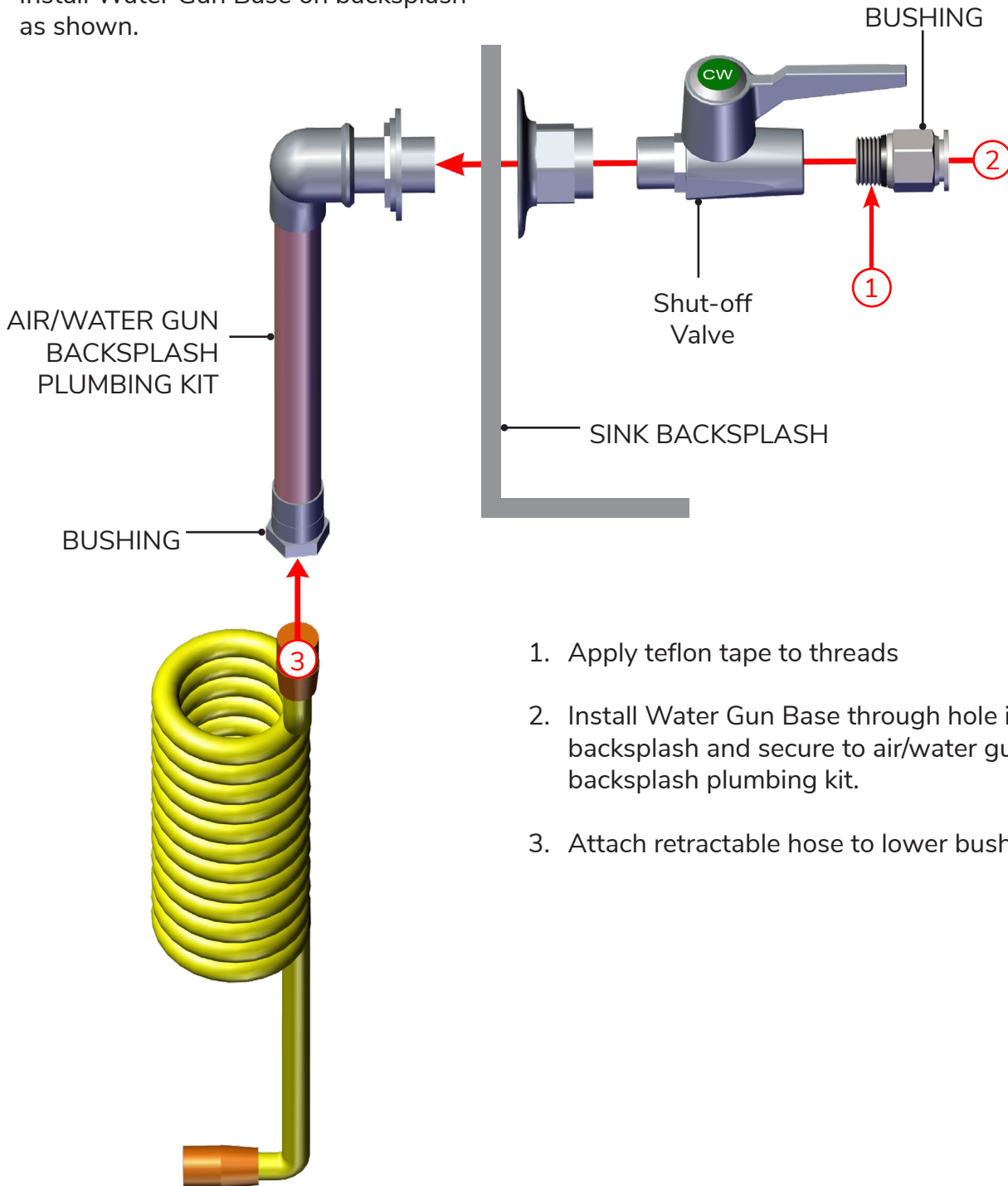

1. Apply teflon tape to threads
2. Install Water Gun Base through hole in sink backsplash and secure to air/water gun backsplash plumbing kit.
3. Attach retractable hose to lower bushing.

**IMPORTANT - DO NOT continue with Steps 2-4 until sink is moved to it's permanent location.**

### STEP #2 - Attach Upper Hose and Water Gun

4. Insert hose into the bushing.

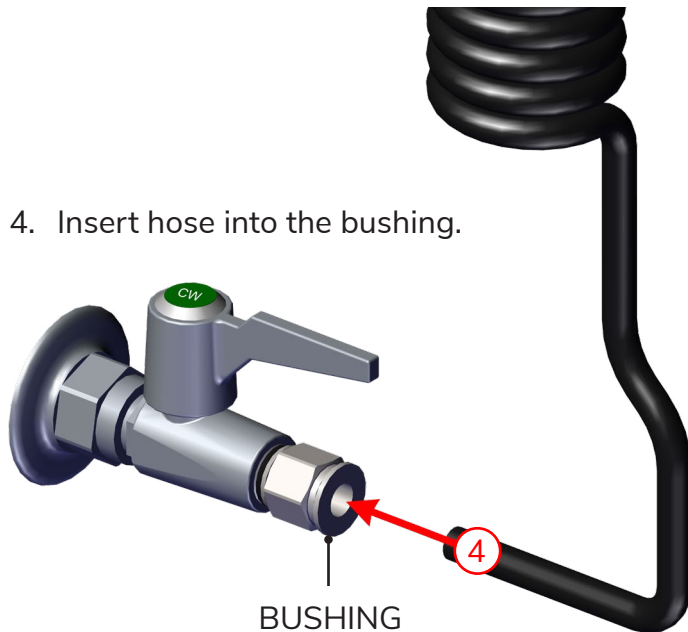

5. Apply teflon tape to threads on bushing.

6. Screw bushing into the handle of the spray gun.

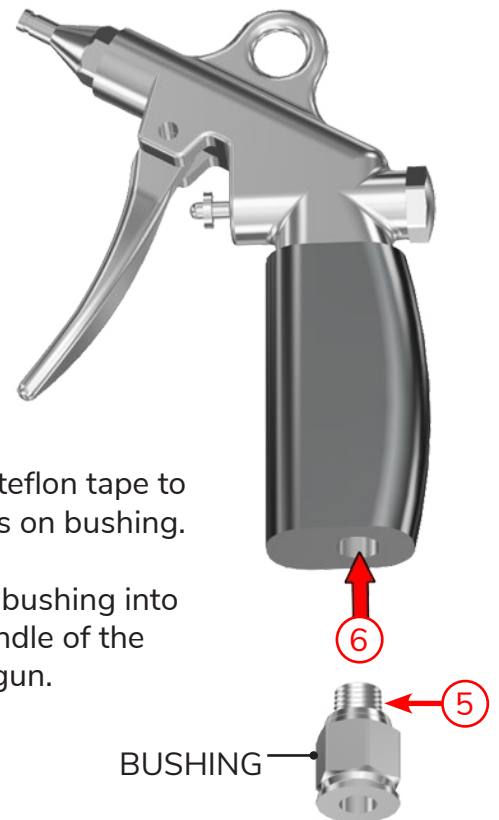

7. Insert the other end of the hose into the bushing.

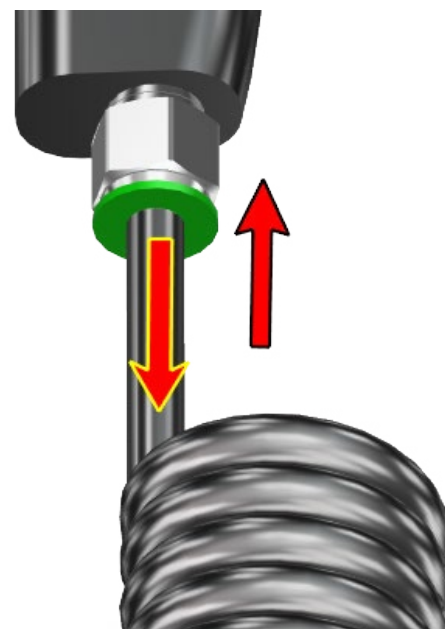
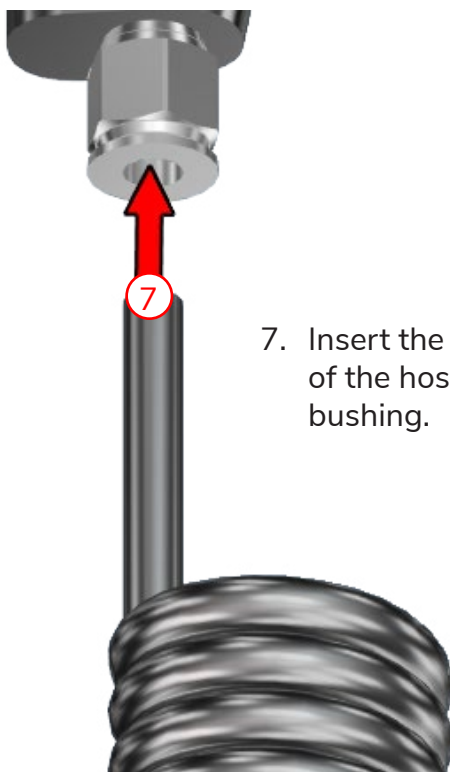

To disconnect the hose from the bushing, press down on the bushing collar (shown in green) and pull the hose out.

### STEP #3 - Assemble Water Gun Tip Bracket

- A. Peel tape backing off bottom of Tip Holder and firmly press down on Water Gun Bracket to secure both parts together.
- B. Insert the eight Tip Attachments onto the retaining posts of the Tip Holder.

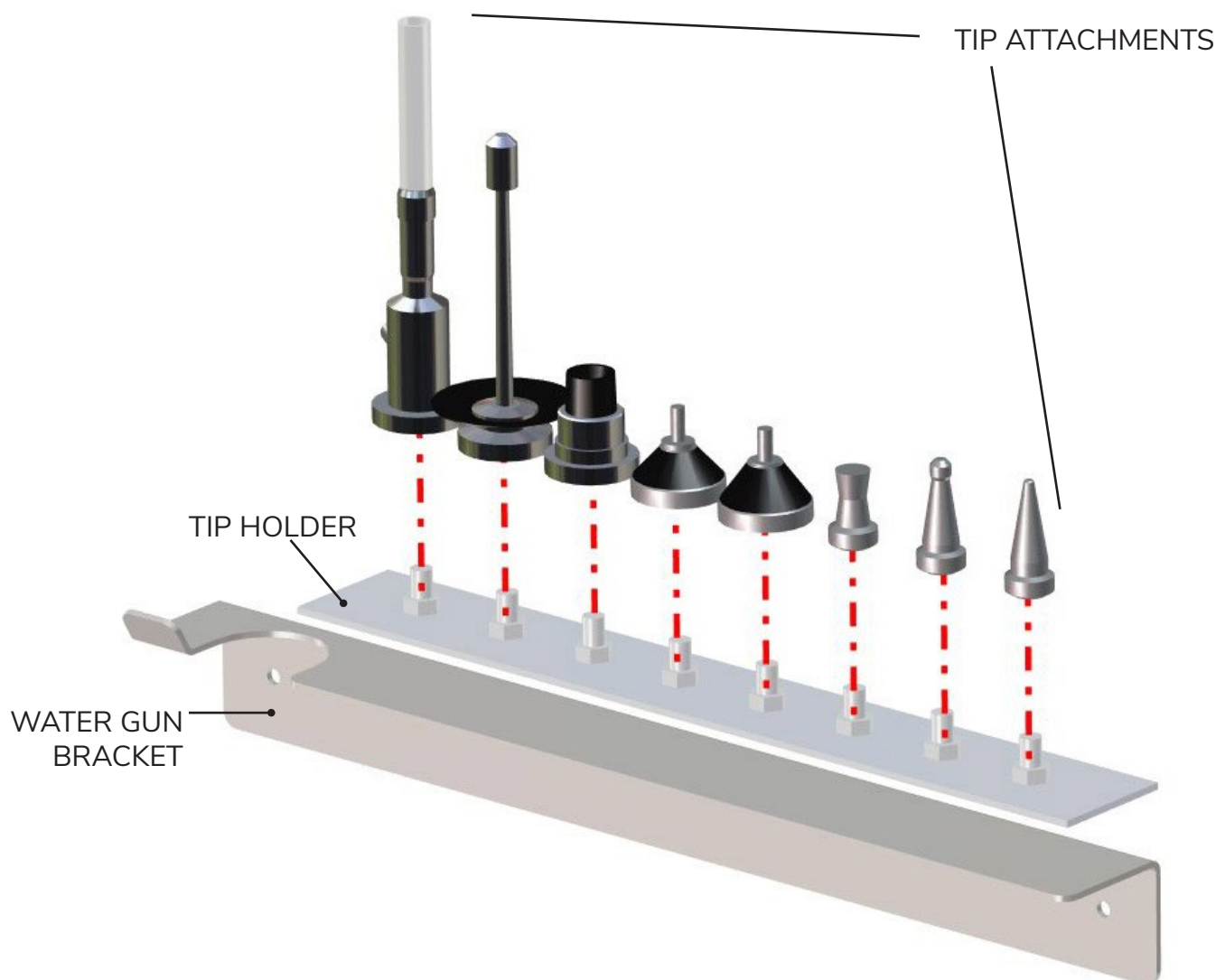

### STEP #4 - Attach Water Gun Bracket to Wall

Use wall anchors and screws to mount the water gun tip bracket to the wall. Mount bracket 15" from top of backsplash to top of bracket.

Qty needed: 4 screws and 4 anchors for the water gun tip bracket.

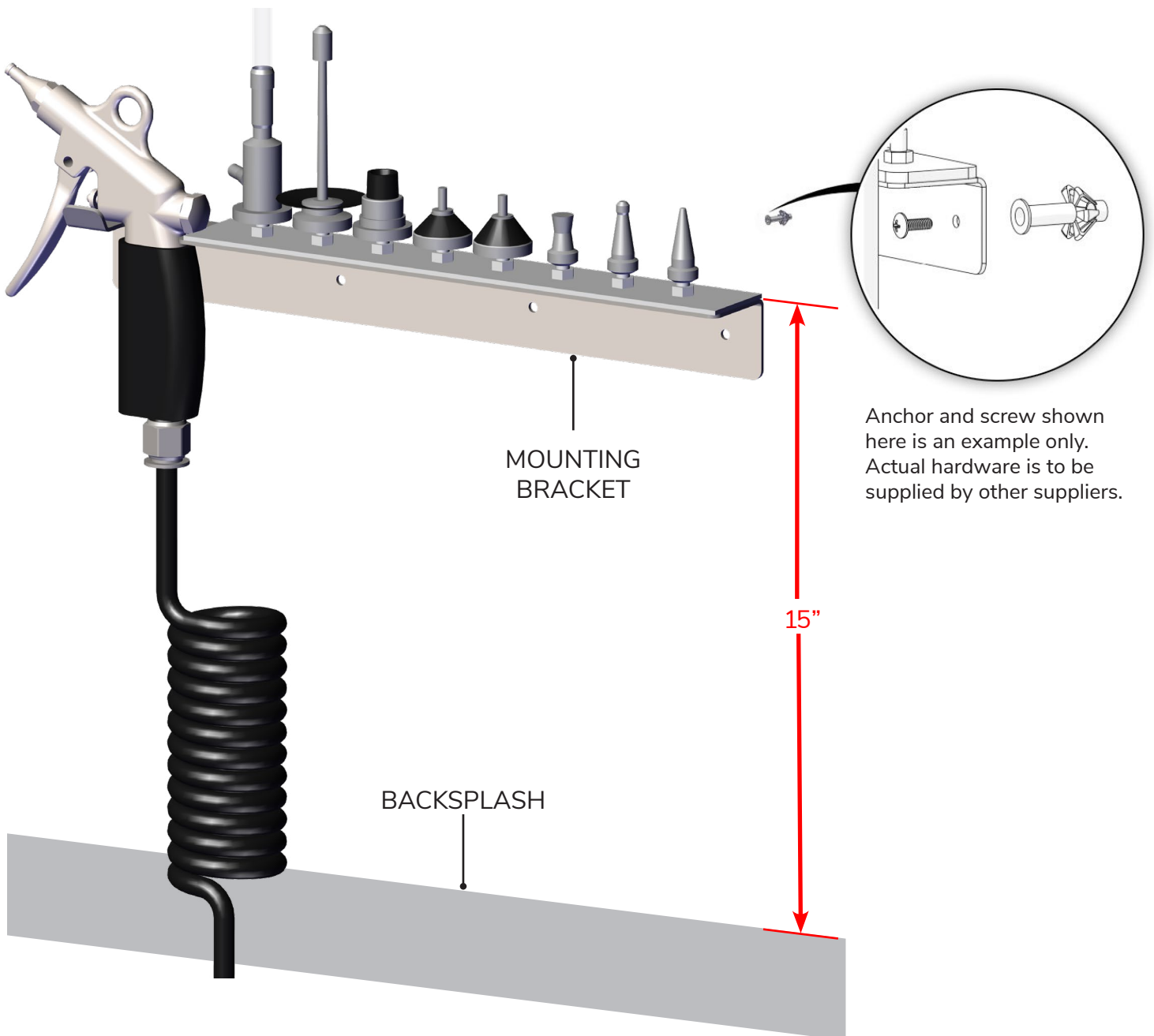



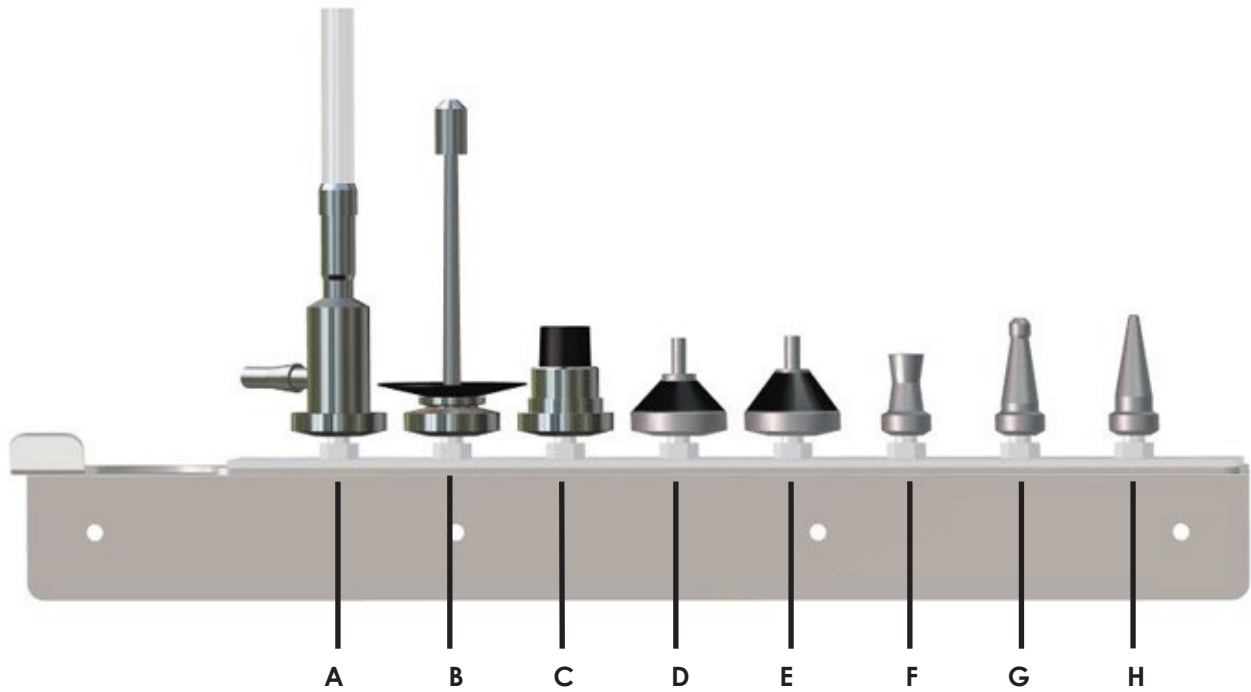

### Tip Attachments and Their Purpose



Tip	Purpose
A	Water jet pump for suction cleaning
B	For bottles and Erlenmeyer flasks
C	For Measuring and blood pipettes
D	For syringes and cannulas with record cone
E	For syringes and cannulas with Luer cone
F	Spray Jet for rapid instrument cleaning
G	For drainage tubings
H	For catheters, valves, etc.

### Safe Use of the Water Gun

1. Prior to operation, make sure all tip attachments are properly seated on the safety cone by firmly pushing them all the way down on the gun tip.
2.  **CAUTION:** Maximum water pressure allowed for use with this equipment is 86 PSI (6 bar).
3. Make sure supply valve (attaching the Water Gun to the supply) is open.
4.  **CAUTION:** Do not point the Water Gun toward the body. The highly compressed water or air output can cause severe injury to exposed flesh.
5.  **CAUTION:** Wear appropriate Personal Protection Equipment (PPE). Due to potential splashes of contaminated fluids, it is recommended that a full face shield and protective gloves be worn during operation.
6. If required, the maximum water or air pressure can be adjusted by turning the small threaded adjustment nut located behind the trigger handle. (See second picture - right.)
7. The flow is controlled by pulling the Trigger Handle up to the maximum set point fixed by the threaded adjustment nut. (See second picture - right.)
8.  **CAUTION:** Shut-off valve should be turned off when not in use.
9.  **CAUTION:** The Water Gun is **NOT** a medical instrument and is therefore **NOT** for use as part of medical treatments.

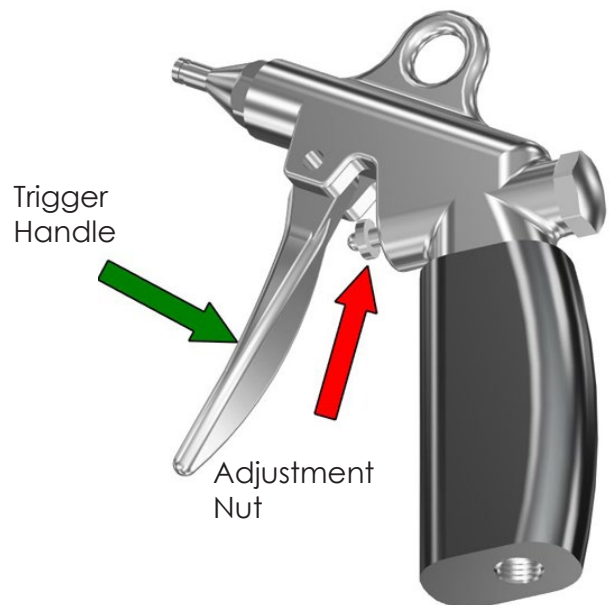
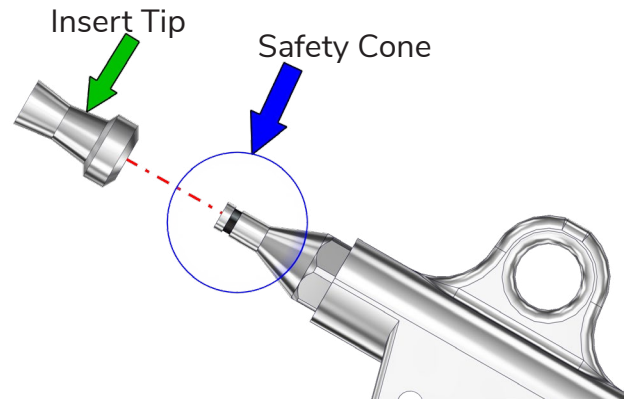

### Replaceable Water Gun Kit Parts

#### Water Gun Kit (PSKT-05)

The Water Gun comes in a kit and is for connection to water lines. See the parts list below for the contents of the kit.

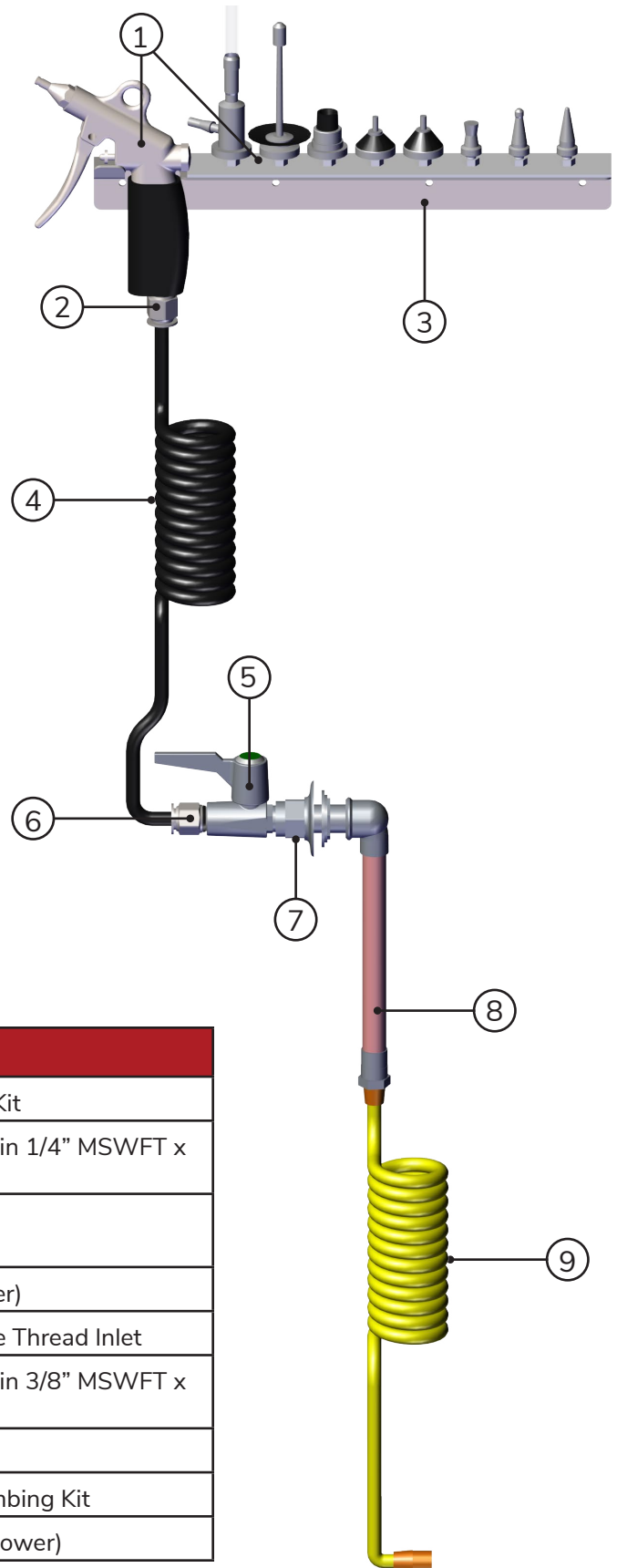

Item #	Part #	Description
1	H0201-06	Water Gun & Tip Attachments Kit
2	H0210-11	Stainless Swiftfit Straight Push in 1/4" MSWFT x 3/8" Tub
3	S02212-131516	Air Gun Bracket
4	H0210-10	8' Retracting Water Hose (Upper)
5	H0178-05	Single Ball Valve, 3/8" NPT Male Thread Inlet
6	H0210-12	Stainless Swiftfit Straight Push in 3/8" MSWFT x 3/8" Tube
7	H0210-21	Flange
8	PS16C-02	Air/Water Gun Backsplash Plumbing Kit
9	H0208-01	8' Retracting Air/Water Hose (Lower)



### Cleaning Instructions for the Water Gun

- The Black Grip on the Water Gun must be cleaned only with warm water and a mild detergent.
- It is not necessary to perform quality checks on the water supply, but when using the Water Gun for water applications, the user should not use demineralized water. Demineralized water will cause corrosion inside the Water Gun body.
- The supplier recommends the user decalcify the Water Gun approximately every four (4) weeks to prevent the build-up of calcium deposits.
- The supplier recommends the user decalcify the Water Gun by submerging it in a decalcifying agent approximately every four (4) weeks to prevent the build-up of Calcium deposits. This will extend the life and operation of the Spray Water Gun. Decalcifying agents can include Distilled White Vinegar, CLR, etc.

For cleaning with Distilled White Vinegar, disconnect the water gun from the hose and submerge the gun in a bowl filled with 1:1 mixture of Distilled White Vinegar and warm water. Leave to soak for 30 minutes. Remove the Water Gun and rinse off with cold water. Reattach the water gun to the water supply hose and operate the gun for 30 seconds to rinse out the interior components of the gun.

For cleaning with CLR, disconnect the water gun from the hose and submerge the Water Gun in 1:1 mixture of CLR and hot water. Leave in CLR for two minutes, remove, and then rinse the exterior with cold water. Reattach the water gun to the water supply hose and operate the gun for 30 seconds to rinse out the interior components of the gun.

Note: When using CLR or other harsh chemical cleaners, refer to the manufacturer's instructions for proper handling, use and disposal of such cleaners.

## Assemble and Install DI Water Faucet (PSKT-03)

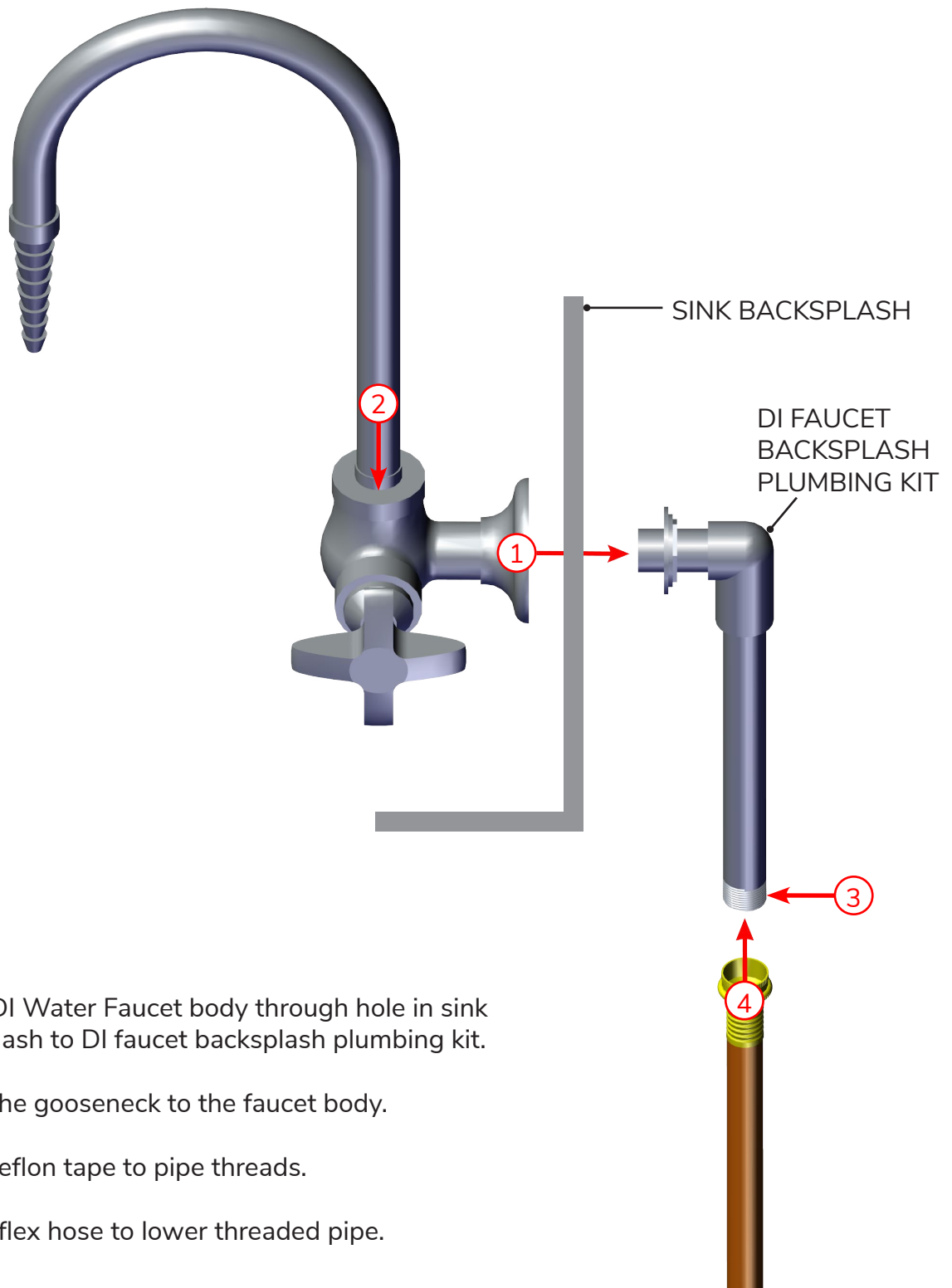

1. Install DI Water Faucet body through hole in sink backsplash to DI faucet backsplash plumbing kit.
2. Install the gooseneck to the faucet body.
3. Apply teflon tape to pipe threads.
4. Attach flex hose to lower threaded pipe.

### Replaceable DI Water Faucet Parts

#### DI Water Faucet (PSKT-03)

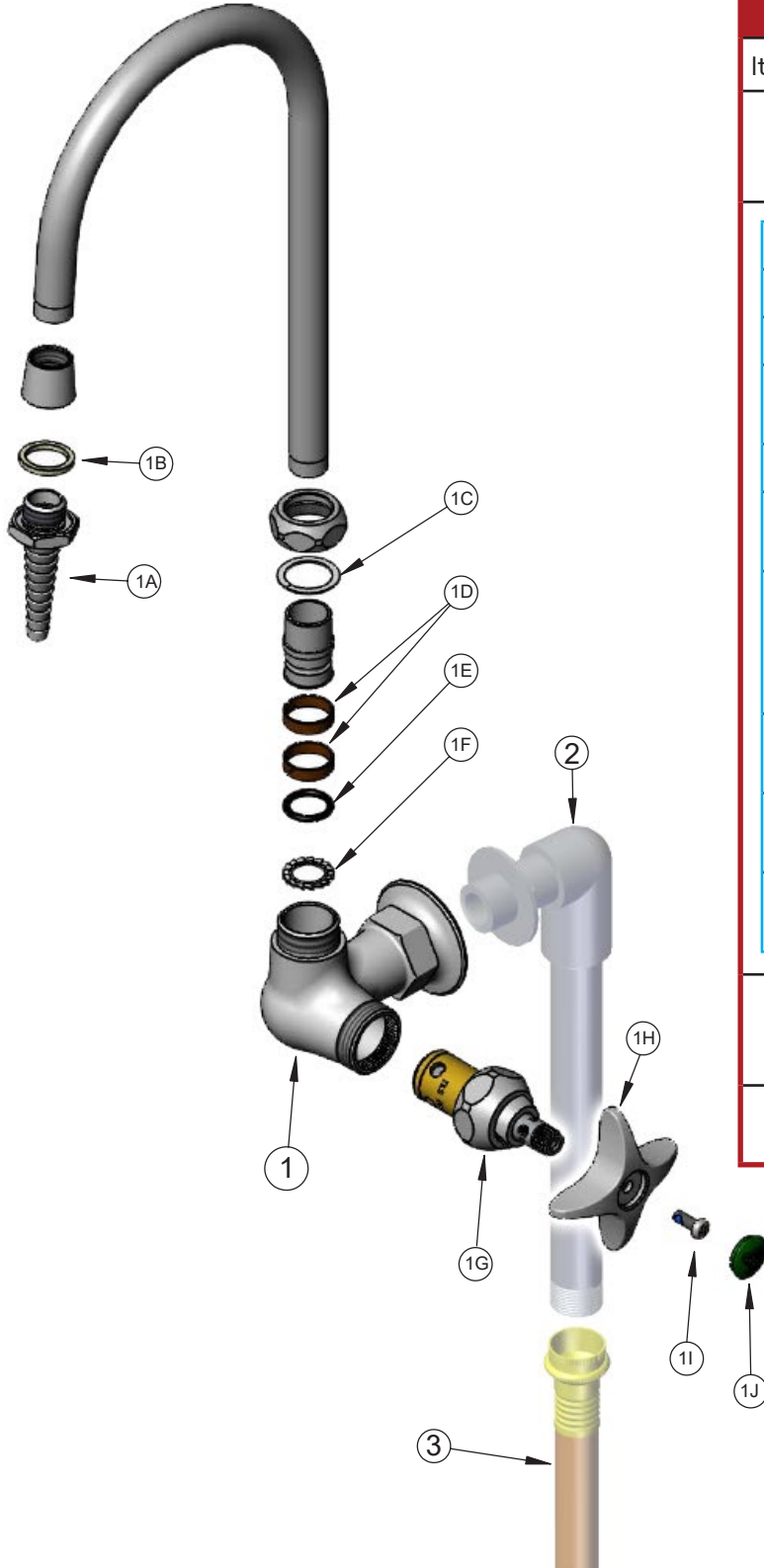

#### PSKT-03 - Entire Kit

Item #	Sales #	Description
1	H0132-02	Faucet Kit Including Base & Items 1A-1J
1A	MM-B-0198	Serrated Tip
1B	MM-001051-45	Washer
1C	MM-009538-45	Swivel Washer
1D	MM-011429-45	Swivel Sleeves (2)
1E	MM-001074-45	O-Ring
1F	MM-014200-45	Star Washer, Anti-Rotation
1G	MM-012443-40NS	Quarter-Turn Eterna Cartridge w/ Spring Check, RTC
1H	MM-002521-45NS	4-Arm Handle (New Style)
1I	MM-000925-45	Lab Handle Screw
1J	MM-001191-45NS	Green "CW" Lab Button Index
2	PS16C-03	DI Faucet Backsplash Plumbing Kit
3	H0210-05	36" Braided Flex Hose

## Assemble and Install Gooseneck Water Faucet (PSKT-02)

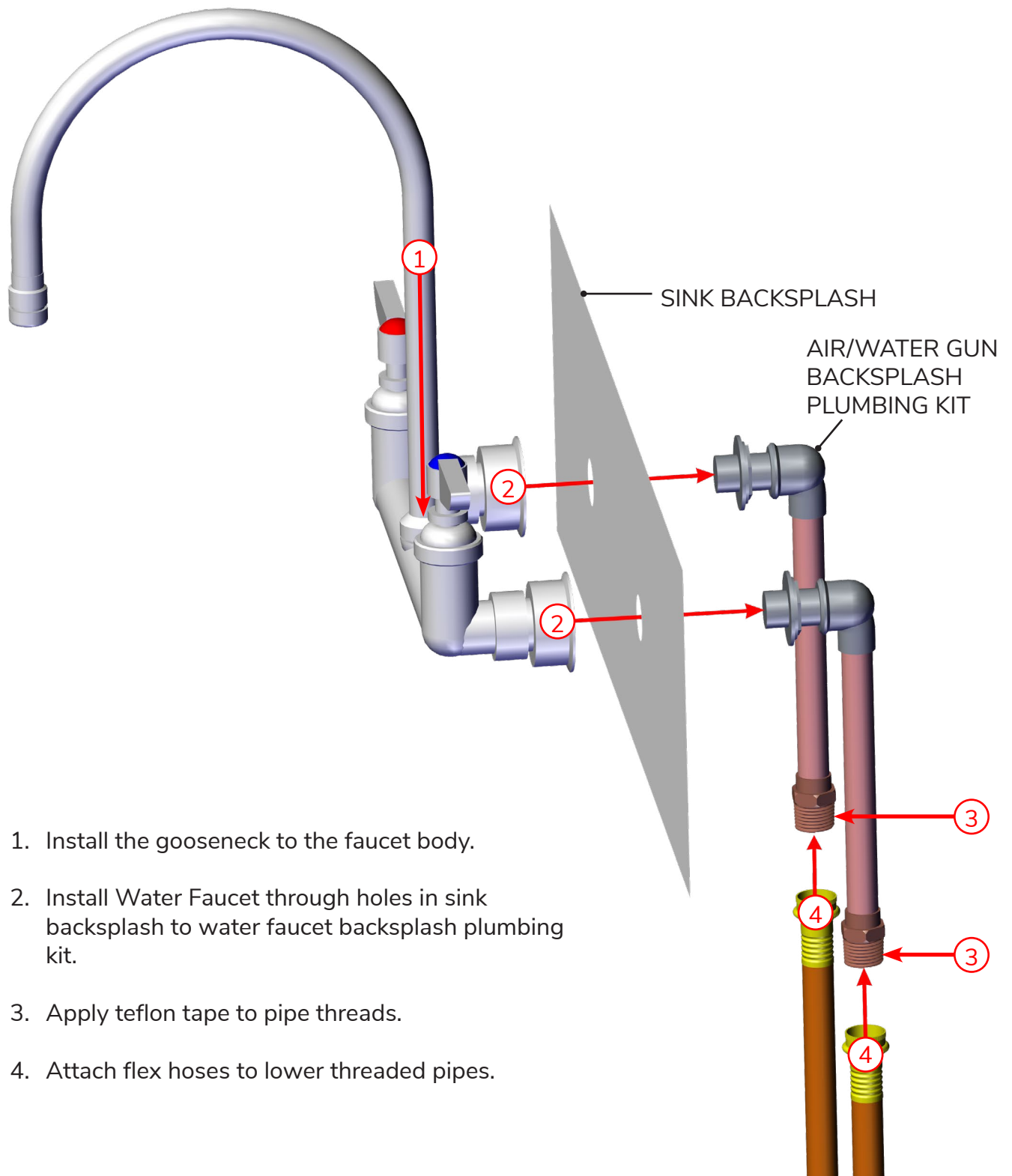

1. Install the gooseneck to the faucet body.
2. Install Water Faucet through holes in sink backsplash to water faucet backsplash plumbing kit.
3. Apply teflon tape to pipe threads.
4. Attach flex hoses to lower threaded pipes.

### Replaceable Gooseneck Water Faucet Parts

#### Gooseneck Water Faucet (PSKT-02)

PSKT-02 - Entire Kit		
Item #	Sales #	Description
1	H0192-14	Faucet Kit Including Base & Items 1A-1G
1A	MM-KL54-Y001-XZ	Faucet Body Assembly
1B	MM-KL50-Y007	Hot Valve Assembly
1C	MM-KL50-Y006	Cold Valve Assembly
1D	MM-K50-0110	Lever Handle Replacement Kit W/Screw
1E	MM-KL50-X132	Stream Regulator Screen
1F	MM-KS11-12-X001	Gooseneck Spout, 8" Adjustable
1G	MM-KN50-X120	Aerator 55/64 Stream Female 2.2 Gpm
2	PS16C-01	Water Faucet Backsplash Plumbing Kit
3	H0210-05	36" Braided Flex Hose

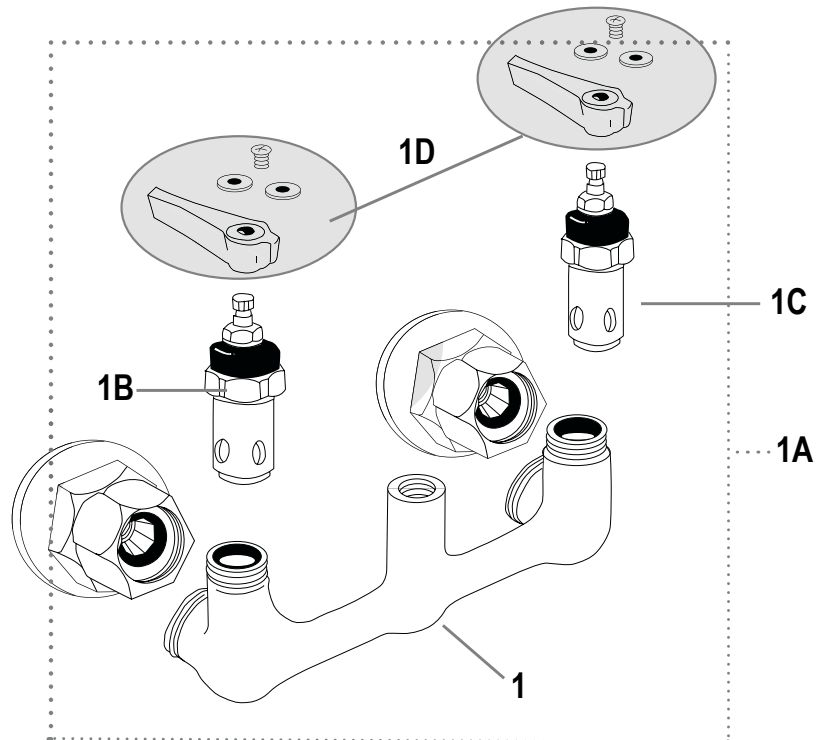
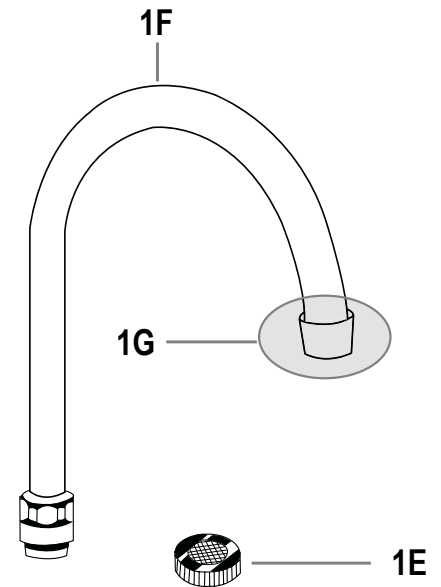

### Foot Levelers (H0090-05-03) and Floor Anchor (S02212-26-PSFA)

After the sink is assembled, the water/air lines connected and the sink located in its permanent location, level the sink and secure it to the floor.

There are four foot leveler locations as circled in red.

The two floor anchors and their correct locations are also shown (highlighted in green).

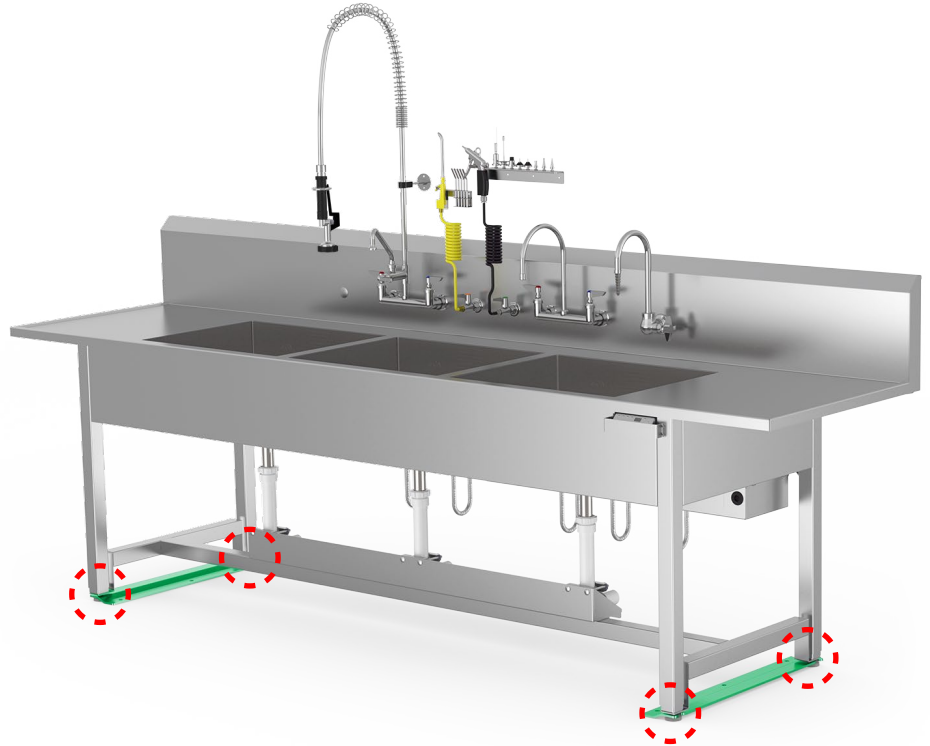

To level the sink, use a wrench to rotate each foot leveler up or down to the desired level height.



After leveling the sink, attach the two floor anchors to the foot levelers located at both ends of the sink and bolt to the floor in accordance with local codes.

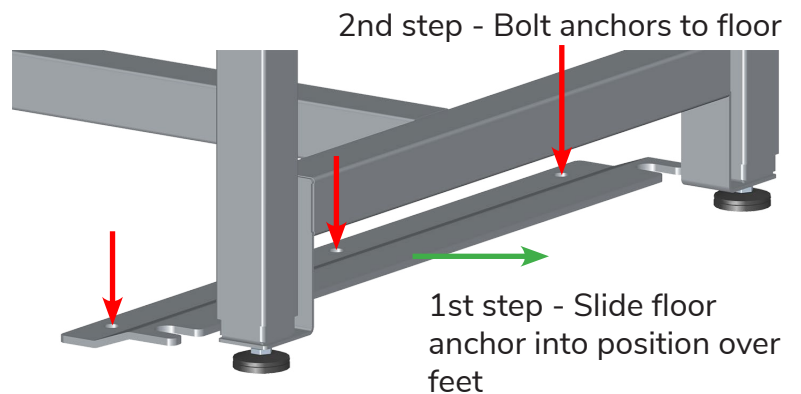

### Fixed Height Sink Waste Drains

Fixed height processing sinks come with the Standard Waste Drain Basket pre-installed (Part # H0150 pictured below) or optional lever handle waste drain (Part # H0142 pictured below)

Note: No drain piping comes pre-installed with fixed height sinks. This is the responsibility of the installer.

Item #	Part #	Description
1	H0150	Standard Waste Drain
2	H0142	Lever Handle Waste Drain
3	MM-D10-X014	3" Drain Cover
4	MM-DBN-X0008	Overflow Cap
5	S0700-125RD	Poly Slip Nut Washer for Dish Washer Connection on H0142
6	S0700-200RD	Poly Slip Nut Washer for Reducer
7	H0142-04	Stainless Steel Drain Reducer and Washer
8	S0700-180RD	Poly Slip Nut Washer for 1 1/2" Drain

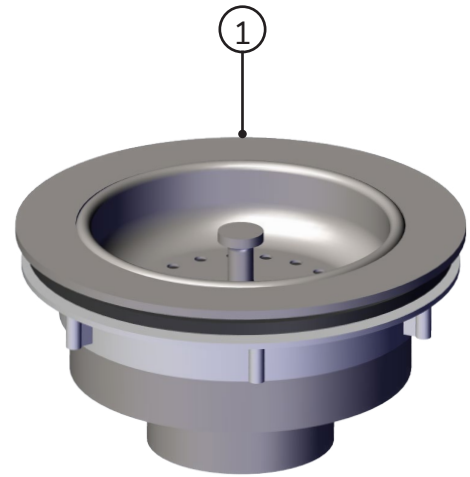

Standard Waste Drain

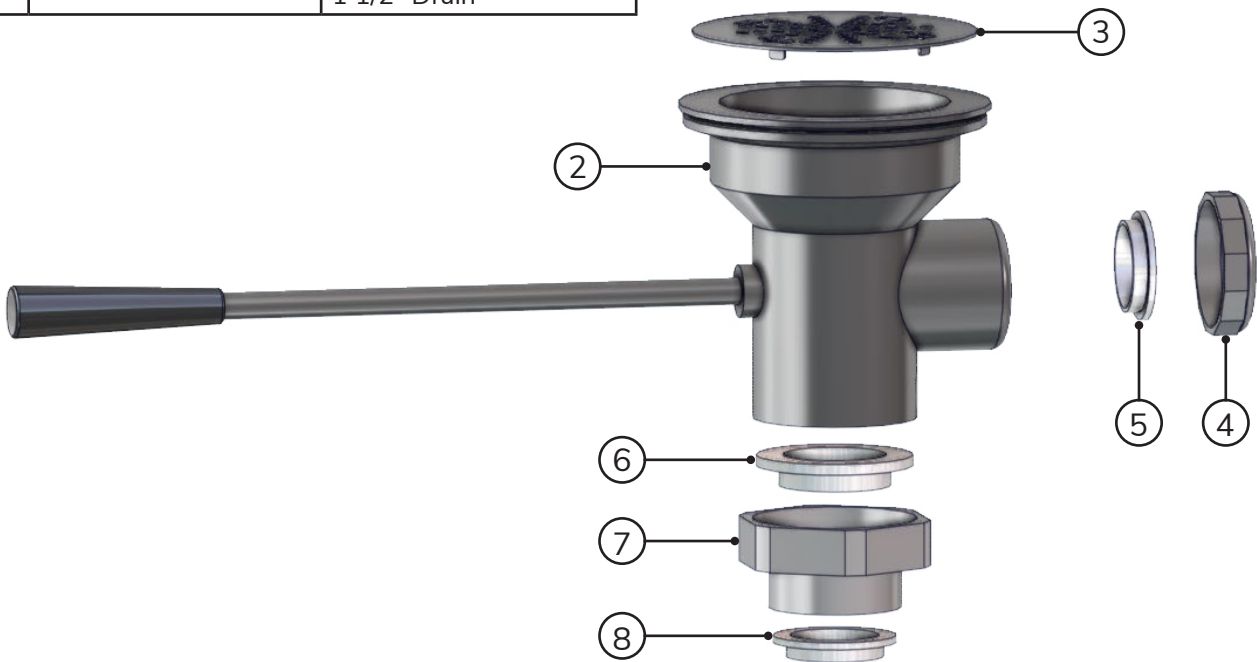

Optional Lever Handle Waste Drain

### Adjustable Height Sink Waste Drains

Adjustable height processing sinks can be equipped with pre-installed standard waste drains or optional lever handle waste drains. PVC trap adapters are standard, but can be upgraded to copper with either drain type.

As needed, parts for the Waste Drain Assemblies can be ordered. See the parts lists below for part numbers and descriptions.

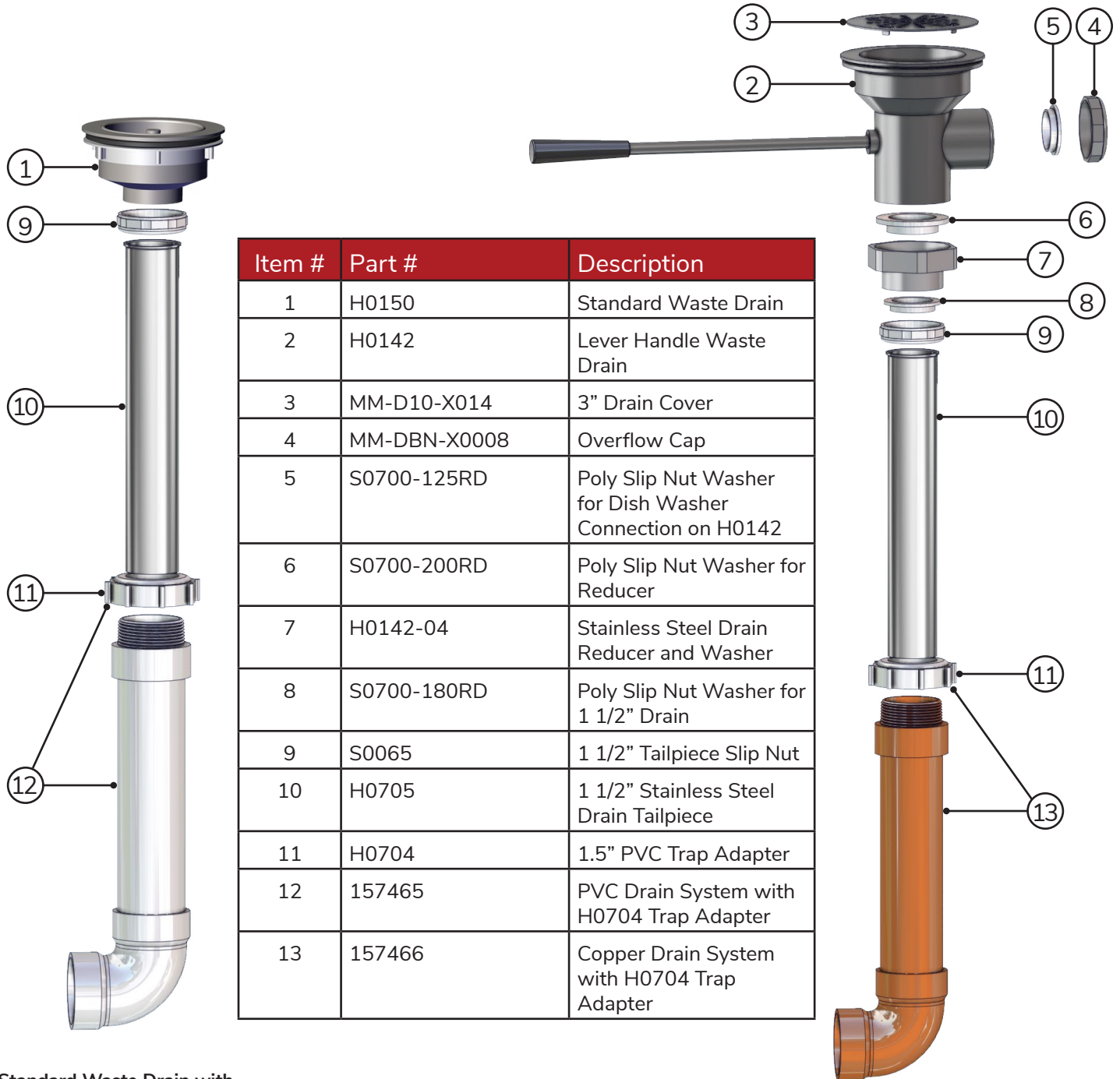

Item #	Part #	Description
1	H0150	Standard Waste Drain
2	H0142	Lever Handle Waste Drain
3	MM-D10-X014	3" Drain Cover
4	MM-DBN-X0008	Overflow Cap
5	S0700-125RD	Poly Slip Nut Washer for Dish Washer Connection on H0142
6	S0700-200RD	Poly Slip Nut Washer for Reducer
7	H0142-04	Stainless Steel Drain Reducer and Washer
8	S0700-180RD	Poly Slip Nut Washer for 1 1/2" Drain
9	S0065	1 1/2" Tailpiece Slip Nut
10	H0705	1 1/2" Stainless Steel Drain Tailpiece
11	H0704	1.5" PVC Trap Adapter
12	157465	PVC Drain System with H0704 Trap Adapter
13	157466	Copper Drain System with H0704 Trap Adapter

Standard Waste Drain with standard PVC Drain System

Optional Lever Handle Waste Drain with optional Copper Drain System



### Connection to Drain (Adjustable Height Sinks)

Attach P-trap to drain line, then connect P-trap to either floor or wall drain. Contractor must provide the P-trap and make all drain connections in accordance with local codes.

The example below shows a single section drain line for the triple basin processing sink.

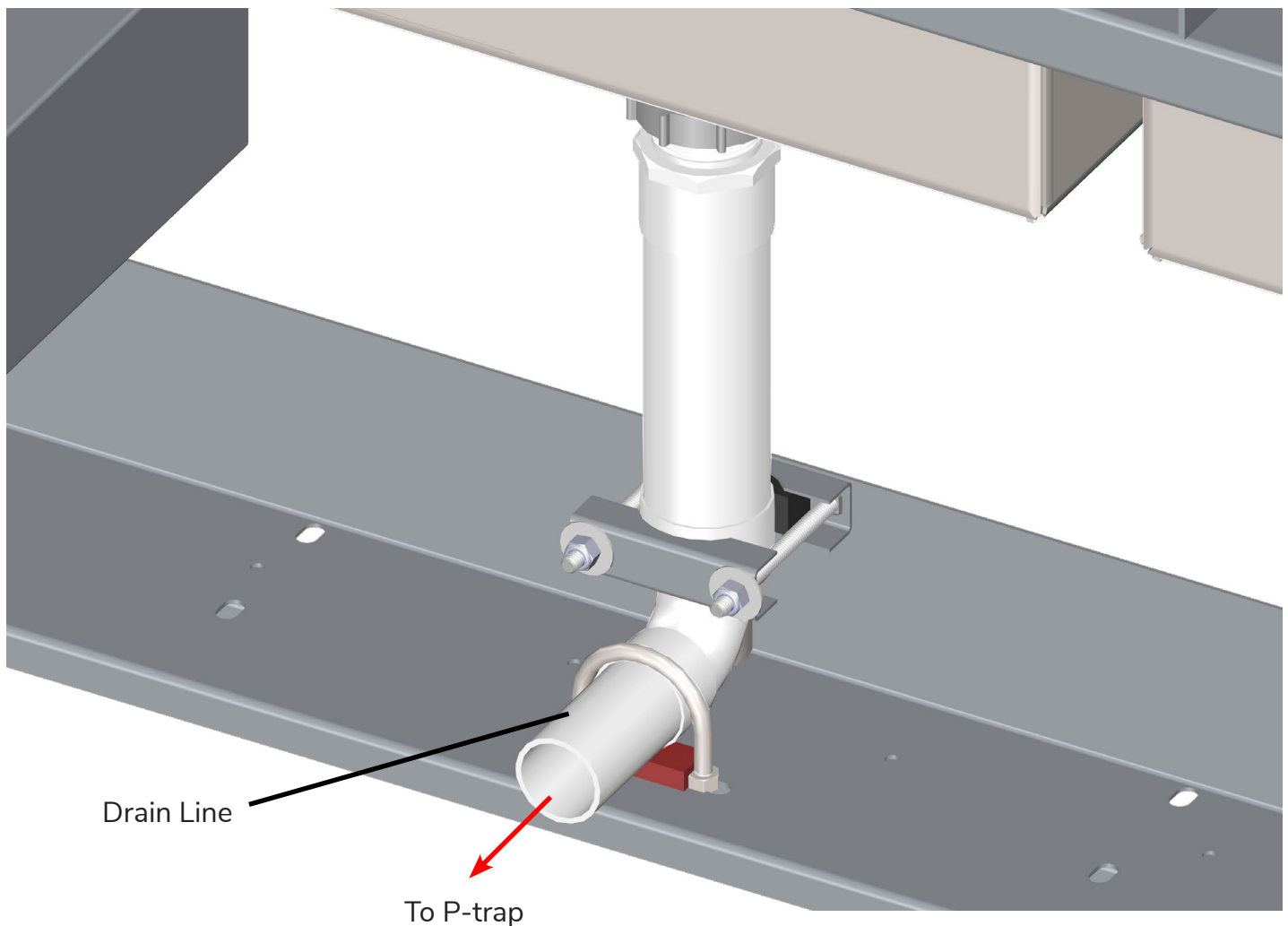

### Air and Water Connections

Note: All water and air connections are to be completed per local codes.

Connection Procedure (going left to right in the back view illustration below. The example here is for a triple basin processing sink):

1	DI Faucet	Connect the incoming water/treated water line hose rated 145 PSI
2a	Gooseneck Faucet	Connect the incoming cold water for the gooseneck faucet
2b		Connect the incoming hot water for the gooseneck faucet
3	Water Gun	Connect the incoming water
4	Air Gun	Connect the incoming airline hose rated 145 PSI
5a	Pre-Rinse Faucet	Connect the incoming cold water for the pre-rinse faucet
5b		Connect the incoming hot water for the pre-rinse faucet

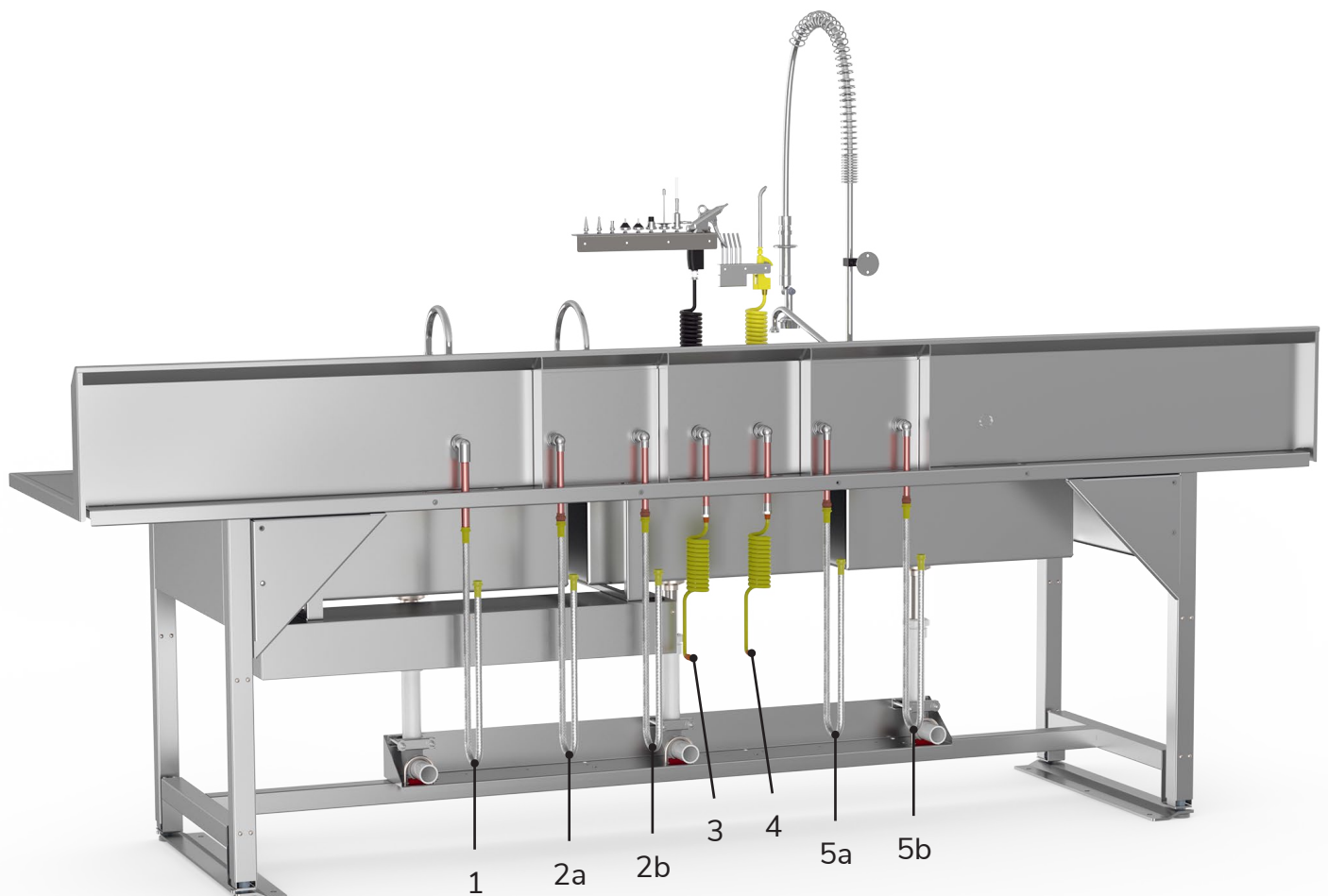

### Adjustable Height Sinks Only - Control Panel Technical Data

The Control Panel feature is available only for Adjustable Height Processing Sinks to operate the hydraulics.

Features	Electrical Specifications
4 Memory Positions	Primary Voltage 120V, 10A
Digital Display of the Height	Engine Voltage 24 VDC
Overload Protection	Nominal Rating Approximately 340 VA
Thermal Protection	Standby Power <0.6W
	Nominal Speed 180 min-1
	Protection Type IP 20

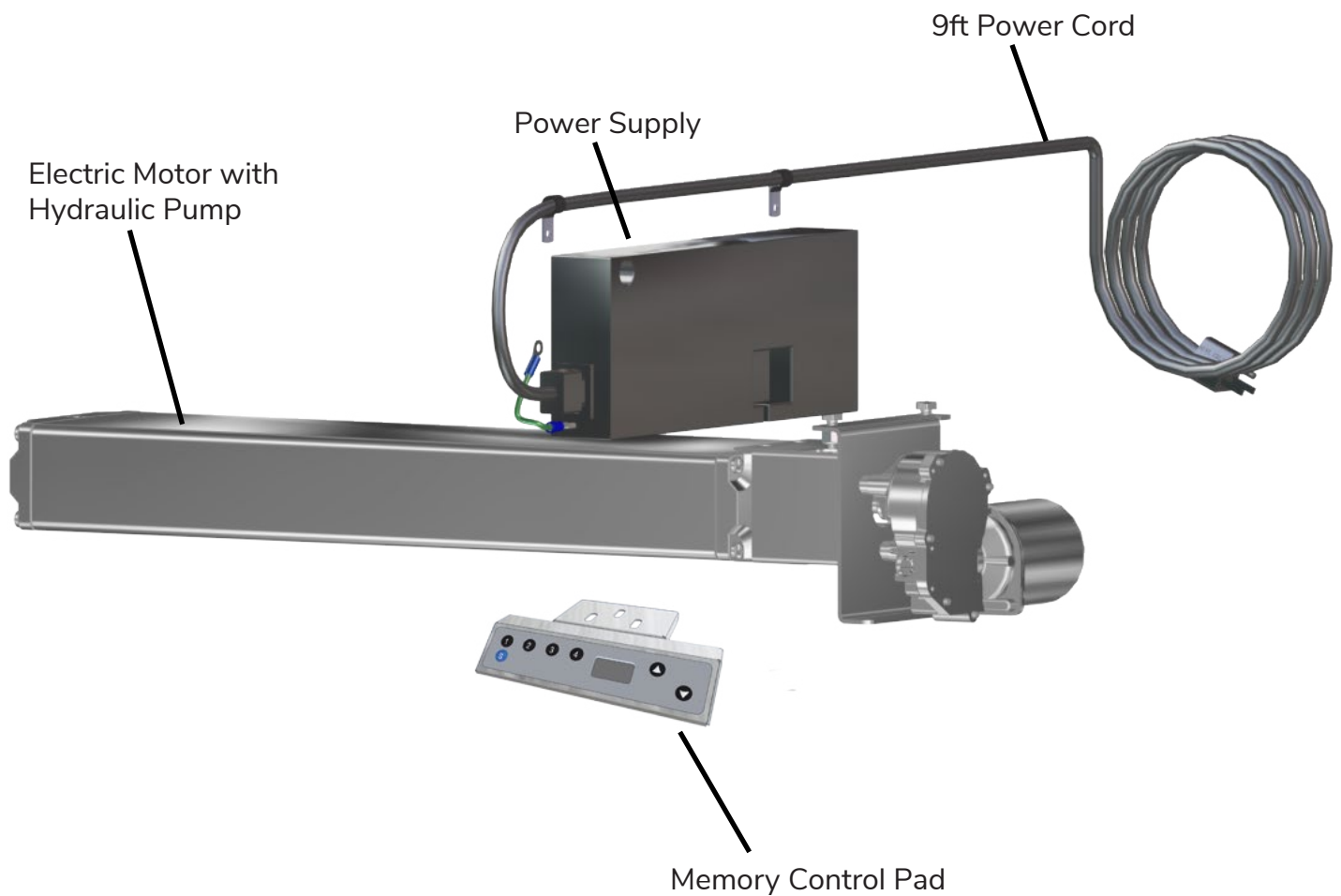

### Adjustable Height Sinks Only - Control Panel Setup and Operation

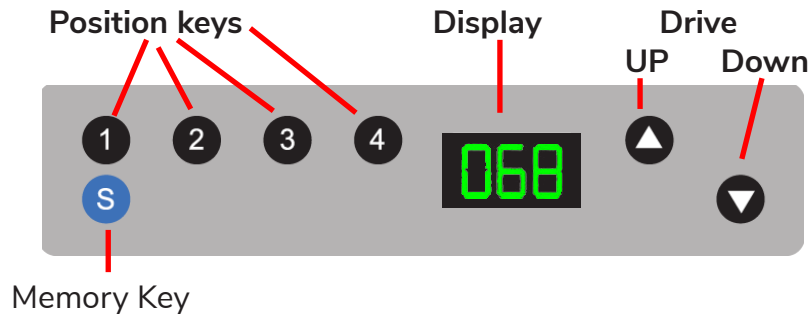

At the first power-on, follow these steps:

Note: US customers will see the values in the display in terms of US Inches. European customers will see display values in terms of EU Centimeters.

1. Operation - drive up / down

This function is used for easy height adjustment of the system.

- ▮ Press the button  or .
- Keep the button pressed until the desired working height is reached.

2. Duty cycle monitoring

The duty cycle monitoring checks for the operation/hold ratio. To avoid overheating of the system a duty cycle of 2/18 (ON/OFF) should be maintained.

The maximum continuous operating time is 2 minutes. Afterwards a pause of at least 18 minutes needs to be observed before the system can be operated again.

3. Saving a memory position

With this function it is possible to memorise a certain position/height and approach it at a later time by pushing one button. With the four memory buttons up to four different positions can be stored and approached.

1. Drive to the desired position and press the button  (Save).

Display: 

2. Press one of the buttons    .

After pressing a memory button the display shows «S» and the number of the pressed button.





Example: 

After saving there is a double click sound, and after approx. 2 seconds the current height is displayed again.

Example: 

#### 4. Approaching a stored position

This function is designed to approach a stored position.

- ▮ Press one of the buttons     .  
The system approaches and stops at the stored position.

#### 5. Setting the shown height on the display



The displayed height can be adjusted with this feature.

1. Drive to any desired height and press the button  (Save).

Display: 





2. Keep the button  pressed for about 5 seconds, until the display starts flashing.

Example: 





3. Now the button  (plus) or  (minus) can be used to set the current height. While doing so, the system does not move!
4. With the correctly set value the new height is saved by pressing  (Save).

#### 6. Reset of the Control Box

##### 8. A. Redefine end positions («S 7»)

1. Press the buttons ,  and  simultaneously, until «S 5» or «S 7» is displayed.
2. Press the button  until «S 7» appears on the display.
3. Press the button  (Save).  
*The display is flashing «068» → carry out initial operation according to chapter 4.*









##### 9. B. Reset control box to factory settings («S 0»)

1. Press the buttons ,  and  simultaneously, until «S 5» or «S 7» is displayed.
2. Press the button  until «S 0» appears on the display.
3. Press the button  (Save).  
*The display is flashing «068» → carry out initial operation according to chapter 4.*

## 7. Programming a replacement/reset control panel

After a PCB Enclosure Assembly has been installed or reset, it must be programmed.

*The display is flashing «068» (US – 110 V version «027»)*

1. Press the button  to drive to the desired lower end position (or to the under block position). The system moves downwards at half speed. Upward movement is disabled.
2. Press the buttons  (plus) and  (minus) to set the current height of the work surface on the display. (in cm, US - 110 V version in inch)
3. To confirm, press  (Save).  
After confirmation the display changes to «088» (US - 110 V version «035») (still flashing).
4. Press the button  to drive to the desired upper end position (or to the upper block position).
5. Press the buttons  (plus) and  (minus) to set the current height of the work surface on the display. (in cm, US - 110 V version in inch)
6. To confirm, press  (Save).

After confirmation the height is displayed (no more flashing) and the initial operation is completed.

**NOTE**

The control box automatically offsets the end positions by one motor turn. Depending on the combination of systems (hydraulic transmission ratio), the system stops its movement 3 mm, 5 mm or 10.5 mm before the defined end position.

### Adjustable Height Sinks Only - Maximum/Minimum Height Levels

The minimum height clearance from the floor for the adjustable height sink is 32.5 inches.

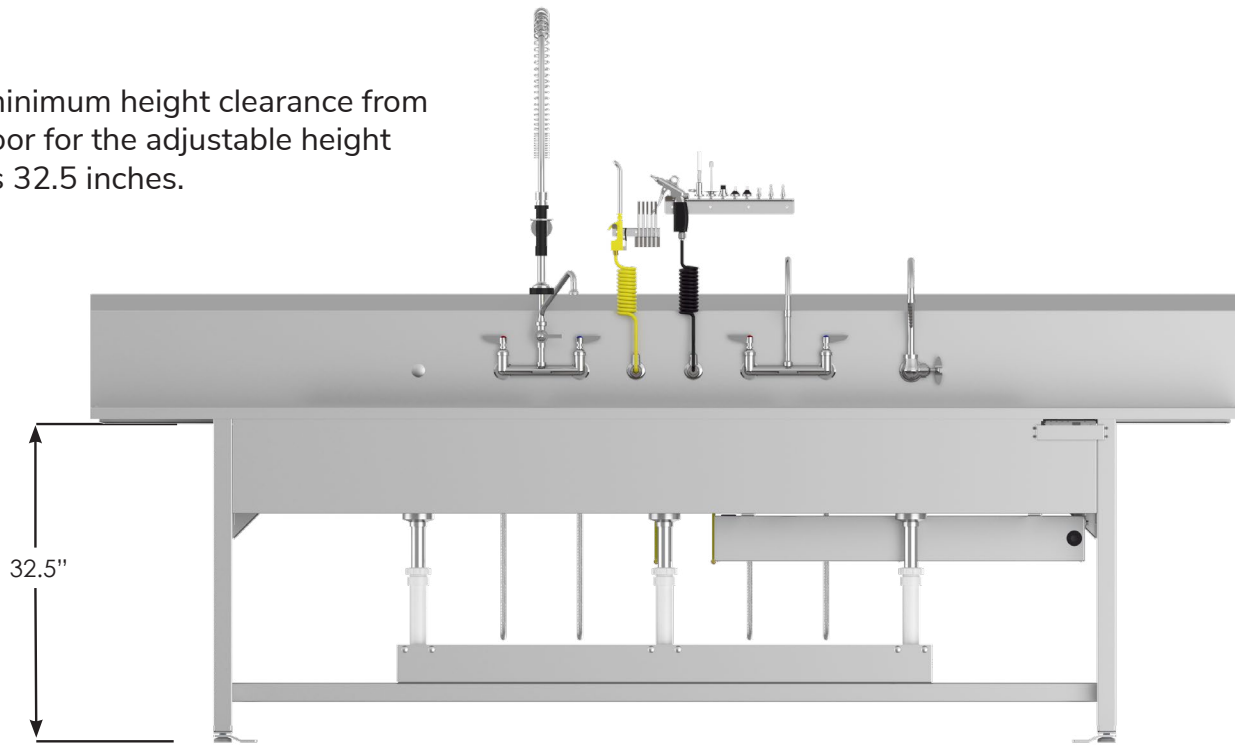

The maximum extended height clearance from the floor for the adjustable height sink is 39.5 inches.

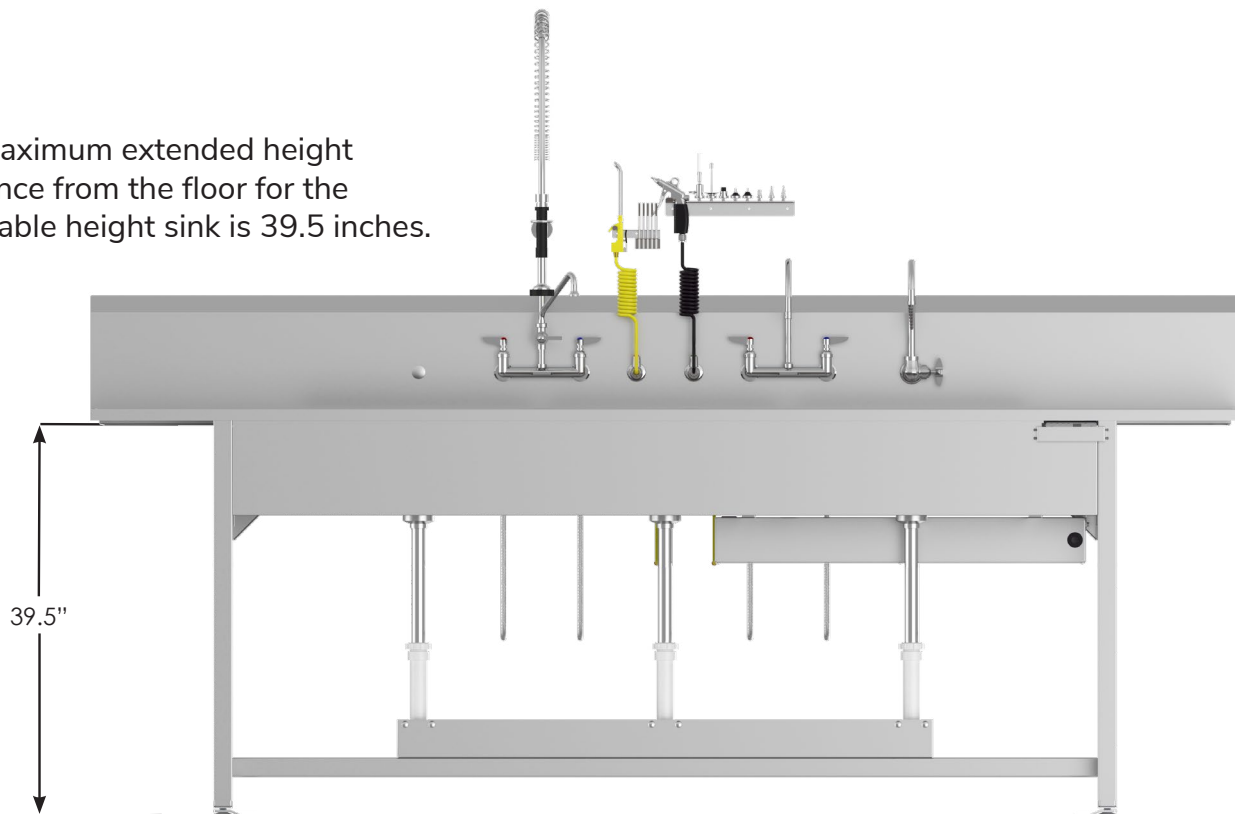

### Adjustable Height Sinks Only - Replacing the PCB Enclosure Assembly



Item #	Part #	Description	QTY
1	PCB-001-ASM Kit	PCB Enclosure Assembly with Power Cord	1
2	H0012-01	Screw, Self Tapping, 8-32 X 1/2" 3	3

#### Removing the Existing Memory Control Pad

To remove an existing PCB Enclosure Assembly due to damage and replace it with a new one:

1. Unplug the PCB Enclosure Assembly cord from the Power Supply Unit (located at the back of the sink on the left side).
2. Remove the three 8-32 X 1/2" self-tapping screws (shown in yellow) attaching the old PCB Enclosure Assembly to the sink.
3. Remove the old PCB Enclosure Assembly (shown in blue).

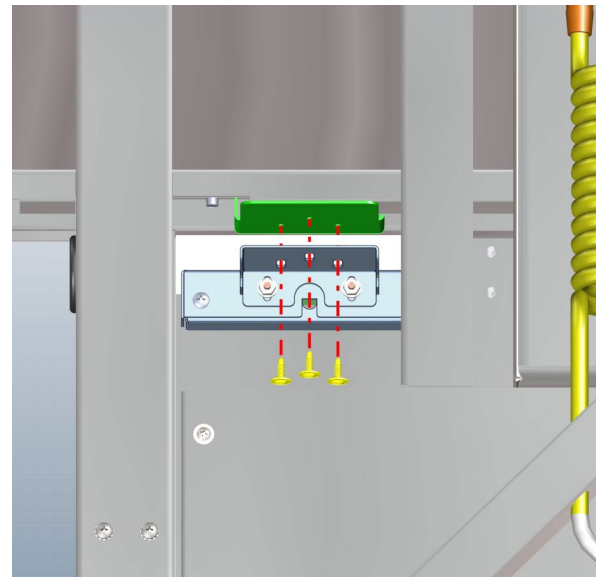



### Installing New PCB Enclosure Assembly

1. Position the replacement PCB Enclosure Assembly (shown in blue) under the front edge of the sink. Align the three holes of the PCB Enclosure Assembly top with holes in the mounting bracket (shown in green).
2. Reinstall the three 8 2 X 1/2" self tapping screws (shown in yellow), attaching the PCB Enclosure Assembly to the sink.

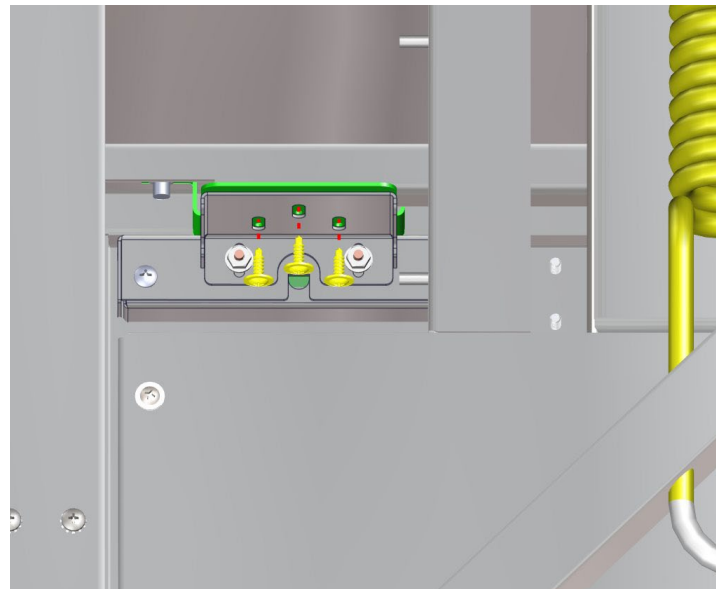

3. Plug it into the bottom receptacle of the sink Power Supply Unit.

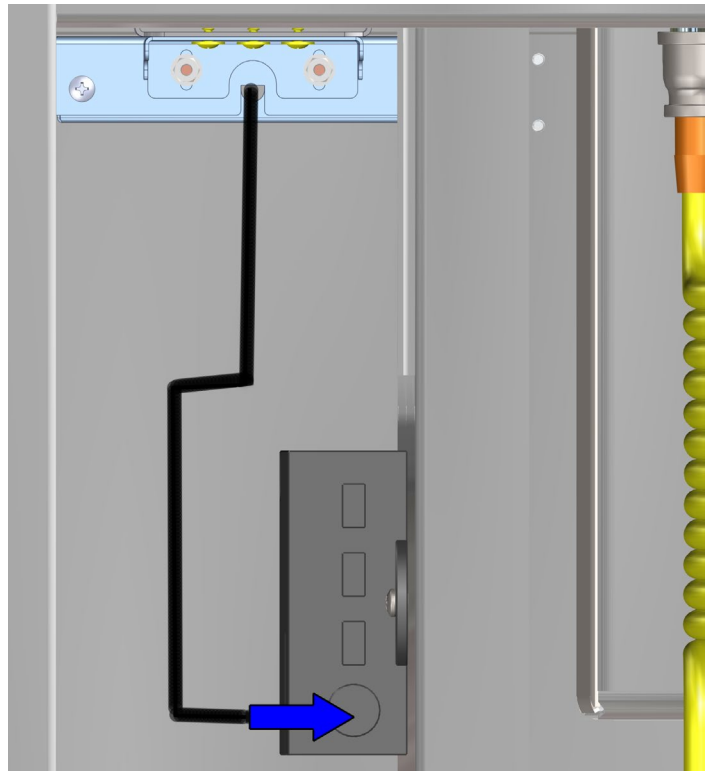



4. See Page 54 for:  
Programming a replacement/reset control panel

### Instructions for Cleaning Stainless Steel Processing Sinks

Stainless Steel Sinks must be cleaned on a regular basis to prevent any unnecessary damage to the stainless steel surfaces.

When cleaning Stainless Steel Sinks, make sure to use the proper approved cleaning agents and cleaning materials.

 <b>CAUTION</b> DO NOT USE these Cleaning Materials	 <b>CAUTION</b> DO NOT USE these Cleaning Agents
Abrasive Pads	Hard Water (water with a pH reading above 7.0)
Scrapers	Hydrochloric Acid
Steel Wool	Steam or high pressure water
Wire Brushes	Bleach or any compounds containing chlorine or Sodium hypochlorite, or ammonium chloride salts

#### Approved cleaning materials and agents

- Soft, clean lint-free cloth
- Non-abrasive cleaning pads
- Soft bristle brush
- Mild detergents
- Sodium Bicarbonate (baking soda)
- Distilled water (pH rating 7) alone or with a mild detergent
- White vinegar (in a spray bottle)
- Isopropyl Alcohol
- Hospital-grade non-bleach disinfectants
- Cleaners approved for use on stainless steel

#### Cleaning Stainless Steel Surfaces

1. Using a damp, lint-free cloth and approved cleaner, wipe down the entire exterior surface of the stainless steel sinks. Using a damp, lint-free cloth with distilled water and a mild detergent, wipe down the entire exterior surface of the stainless steel sinks.
2. Let cleaned sinks air dry.

#### Cleaning Decals or Printed Labels

- Use only distilled water and a mild detergent applied with a clean, dry lint-free cloth to clean decals or printed labels.
- Cleaning agents can remove or smear any printing from decals and print labels.
- Cleaning agents can damage plastic materials used in manufacturing covers for electronic items such as touch-screen pads.

### Index

#### A

##### Air Gun

- Air Inlet Assy, Hose Connections 28
- Parts List 32
- Tips
  - Insertion & Removal 31
  - Use and Cleaning 33

#### B

##### Brackets

- Wall Mounting Pre-Rinse Faucet Bracket 20
- Wall Mounting Air Gun 30
- Wall Mounting Water Gun 37

#### C

##### Connections

- Air & Water 50
- Drain (Fixed Height Sinks) 47
- Drain (Adjustable Height Sinks) 48

##### Control Panel (Adjustable Height Sinks)

- Control Panel Setup & Operation 52
- Installing New PCB Enclosure Assembly 57
- Maximum/Minimum Height Levels 55
- Programming the Replacement Control Panel 54
- Replacing the PCB Enclosure Assembly 56
- Technical Data 51

#### D

##### DI Water Faucet

- Installation 42
- Parts List 43

#### G

##### Gooseneck Water Faucet

- Installation 44
- Parts List 45

#### P

##### Pegboard Backframe

- Installation 15
- Outer Backframe Bracket Install 16
- Bolt Locations and Wire Management 17

##### Power (Adjustable Height Sinks)

- Requirements 13

##### Pre-Rinse Hot/Cold Water Faucet

- Add-on Faucet and Body
  - Installation 19
- Base Faucet
  - Installation 18
  - Parts List 27
- Gooseneck Spring, Assembly 23
- Hook Assembly, Installation 22
- Operation and Maintenance 24
- Parts List 25
- Spray Head Assembly and Grip
  - Parts List 26

#### S

##### Sink

- Adjustable Height Only
  - Max/Min Heights 55
  - Power Source Location 13
- Cleaning Stainless Steel 58
- Components
  - Top Level Parts List 10
- Floor Anchors 46
- Floor Levelers 46
- General Specifications 8
- Installation, Overview 12
- Placement Requirement
  - Distance from Wall for Brackets 14
- Unpacking and Inspection Instructions 11
- Utility Requirements 8

#### W

##### Warranty Information 60

##### Waste Drain

- Lever Handle
  - Parts List 47&48
- Standard 47

##### Water Gun

- Cleaning Instructions 41
- Parts List 40
- Safe Use 39
- Tip Attachments, Purpose 38
- Tip Bracket Assembly 36

## Limited Lifetime Warranty

MAC Medical warrants to the original purchaser that its Proprietary Products will be free from defects in workmanship or materials under normal use and service for the life of the product, so long as owned by the original purchaser, according to the limitations set forth below.

Defective products shall be repaired or replaced at MAC Medical's option at no cost to the original purchaser provided:

1. The customer must obtain a written return authorization supplied by MAC Medical's customer service department. The product must be returned, properly packaged, with a copy of the original sales receipt and copy of the RMA authorization.  
Please call (877) 828-9975 or (618) 476-3550 to receive a return authorization.
2. The customer must pre-pay freight charges to and from MAC Medical and must ship merchandise properly packaged, in a way the product will not be damaged during transit to the factory. MAC Medical does not warranty any freight damage to or from the factory. It is the customer's responsibility to inspect the product for packaging damage before signing the BOL.

This warranty does not apply to products, which have been subject to abuse, misuse, accident, modification, alteration, tampering, negligence, lack of routine maintenance or misapplication; or products that have been repaired by other than MAC Medical or its authorized representatives.

This warranty does not apply to glass, fabrics, vinyl, seat coverings, cushions, padding or their stitching, gluing or installation. Component parts not manufactured by MAC Medical, such as casters, caster inserts, any components made from rubber or plastic, circuit boards, fan heaters, plumbing parts, electrical switches and other components are also excluded. For these component parts, MAC Medical will pass on the original manufacturer's warranty to MAC Medical equipment original purchasers. Please consult factory for questions regarding the warranties of these component parts. This warranty does not apply to custom fabricated products. Consult factory.

UNLESS EXPRESSLY SET FORTH IN THIS WARRANTY, THERE ARE NO OTHER WARRANTIES, WHETHER EXPRESS OR IMPLIED, OF FITNESS AND/OR MERCHANTABILITY OR ANY OTHER WARRANTY IMPLIED BY CUSTOM, USAGE OR COURSE OF DEALING.

Liability of MAC Medical under this warranty is limited to the repair and/or replacement of any products. MAC Medical specifically excludes and disclaims any responsibility for any incidental or consequential damages claimed to have arisen from any defect in workmanship or materials. No representative has any authority to change or enlarge the above warranty or MAC Medical liability. This document supersedes all previous warranty provisions.



# ACART

1416 Bonhill Rd. Mississauga, ON L5T 1L3

WWW.ACART.CA ~ INFO@ACART.CA ~ 1-800-551-0560

© 2023 Acart Equipment