

## About Us

### Our Story

LogiQuip has been in the healthcare storage solutions business since 1992 with principals that have been experts in the field for a combined 90 years.

Our sole focus is hospital storage and distribution systems. Our series of value-added services makes the life of the hospital clinician, logistics officer, purchaser and planner easier.



### Our Mission

Because each hospital’s inventory, supply, and storage requirements are similar in theory, yet diverse in practice and application, our mission is to provide true solutions for inventory, space, storage, and material handling problems on an individual basis. The solution to a specific problem may consist of a single cart or a complete supply storage system! Whatever the answer, LogiQuip makes it workable and efficient.

Our mission: Solving storage and distribution issues with the best products and designs possible. We believe “space” to be one of the hospital’s most expensive capital assets; as such, our philosophy is to use every cubic inch of that very expensive space.

We focus on maintaining infection control standards and functional ergonomics, which are key areas in healthcare storage and distribution.

Our products work in synergy: What we’ve designed for the OR can work in the Cath Lab and vice versa. We have the most varied line of storage and distribution products for all areas of the hospital, from the receiving dock to the OR.

### Our People

We have knowledgeable experienced representation across North America. A healthcare storage solutions adviser can meet with you at your convenience. We have highly trained customer service and CAD layout specialists in our Michigan home office. No job is too big or too small.

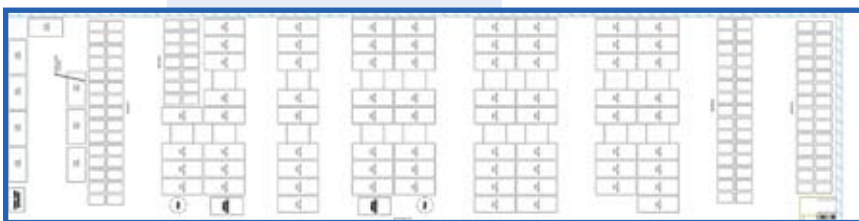

Typical Sterile Processing Layout Before: 1600 linear feet for storage

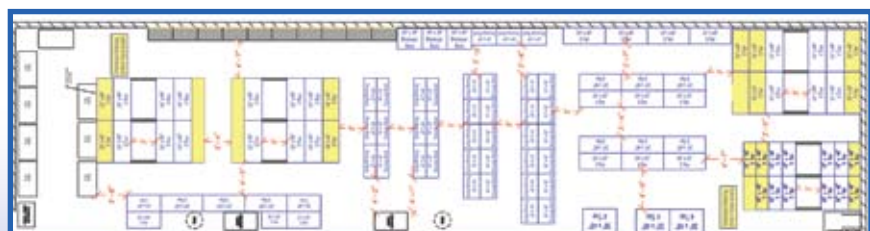

LogiQuip Sterile Processing Layout After: 2700 linear feet for storage

## Table of Contents

Choices - Our Core Products	2
Par Wall® Supply System	3 - 10
Par Stor-III® High Density Storage	11 - 16
LQ Wire Products	17 - 47
Large Supply/Distribution Carts	48 - 57
Utility Carts	58 - 65
Specialty Products	66 - 71
Linen Storage and Distribution	72 - 79
Stores/Plastic Products	80 - 86
Terms and Conditions	87
Index	88 - 89

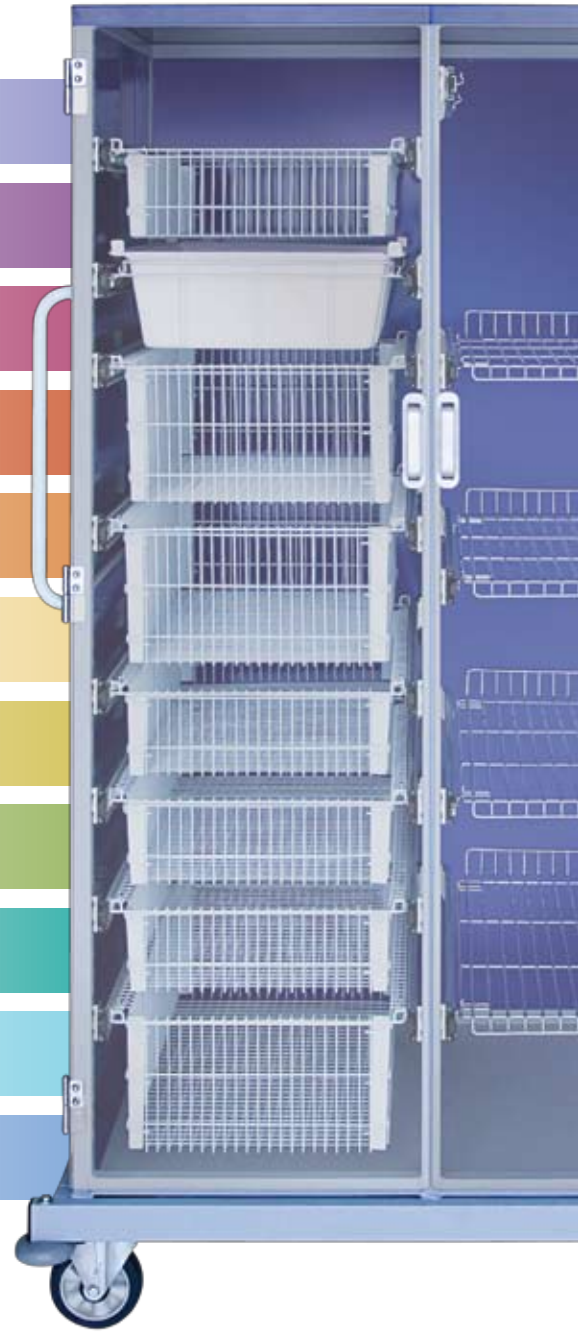



## Choices - Par Wall®, Par Stor®, and LogiCell®

The space for storage in a hospital is at a premium, while supplies need to be accessible, organized and protected. LogiQuip works with key members in the clinical and administrative areas to ensure the highest level of capacity for supplies according to infection control standards, lean concepts and ergonomics.



LogiCell® Cabinetry and Carts  
for Cath Lab, IR and OR



Par Wall® and case carts in the OR Sterile Core

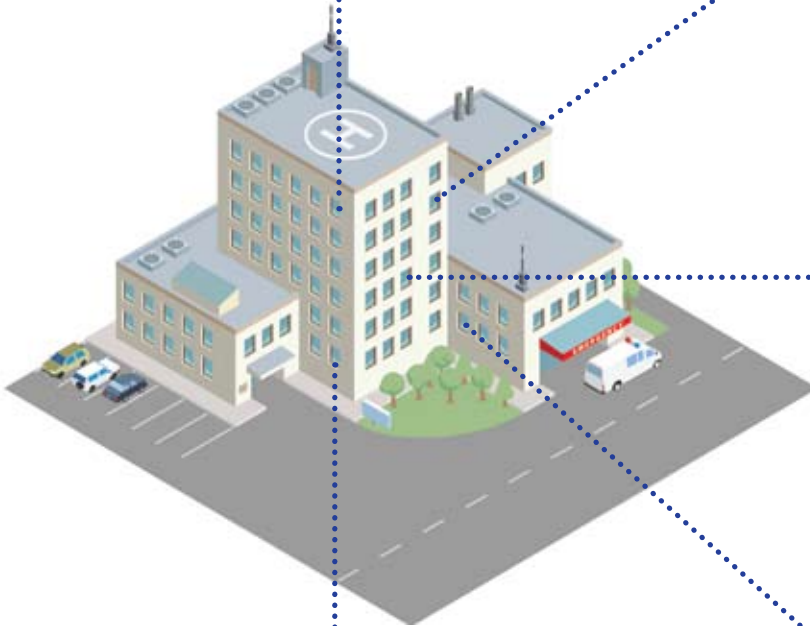

Par Wall®, Par Stor® and Corner Wire Units  
in the Clean Utility Rooms



AF-Carts and Par Wall® in Sterile Processing



LogiCell® Treatment Carts at the Bedside



# Par Wall®

## LEAN & CLEAN STORAGE



OR Core



Sterile Processing



Clean Supply Room



Double-Sided Island Mobile Storage

**Wall-Mount or Freestanding...  
Dozens of Customized Configurations**

*Keep Supplies  
Organized and Accessible*

## Par Wall® Complete Units

### Wall Mount Systems & Unit Breakdown



PWCRTUCH3661  
(group of 2) with 5 spikes

**Par Wall® Wall-Mount Crutch Storage with Spikes:** Complete with 1 panel and 5 or 10 Model #PWHDSPIKE12 Heavy-Duty Equipment Spikes 12" (depending on panel size)

MODEL #	DESCRIPTION	D x W x H
	Par Wall® Wall-Mount Crutch Storage	(inches)
PWCRTUCH3619	Wall-Mount Crutch Storage with 5 Spikes	12 x 37 x 19
PWCRTUCH3661	Wall-Mount Crutch Storage with 10 Spikes	12 x 37 x 61

**Par Wall® Wall-Mount Complete Units- 6 Baskets:** Complete with 1 panel, 1 bottom solid dust shelf, 2-18"D large mesh baskets, 1-18"D fine mesh basket, 3-12"D fine mesh baskets. Each basket complete with mounting brackets, 5 front/back dividers and full-length label holders.

MODEL #	DESCRIPTION	D x W x H
	Par Wall® Complete Wall-Mount Unit	(inches)
PARWALL18-W	Complete Wall-Mount Unit, 6 Baskets	18 x 19 x 61
PARWALL36-W	Complete Wall-Mount Unit, 6 Baskets	18 x 37 x 61



PARWALL36-W  
(group of 4)

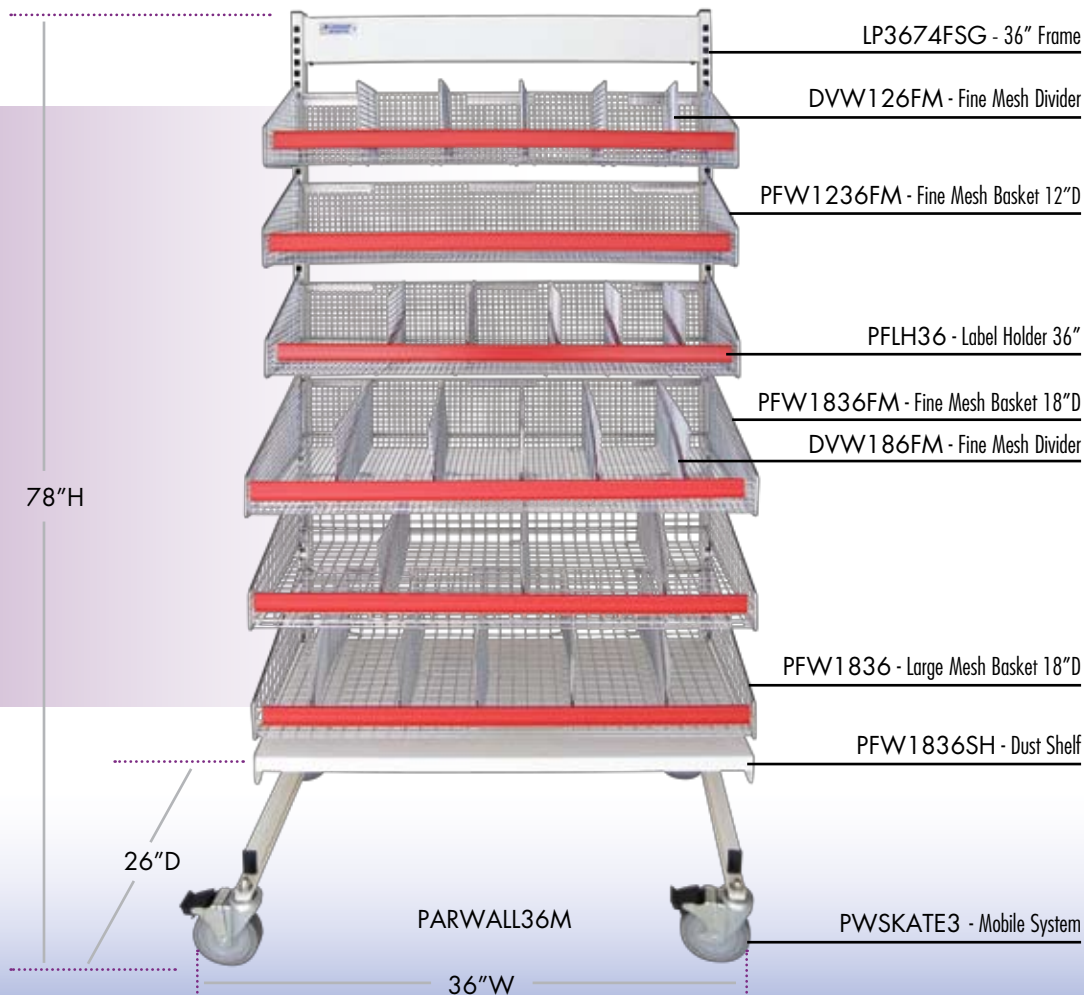

## Par Wall® Complete Units

### 6 Baskets

#### Par Wall® Single-Sided Stationary and Mobile Complete Units:

Complete with 1 frame, 1 bottom dust shelf, 2-18"D large mesh baskets, 1-18"D fine mesh basket, 3-12"D fine mesh baskets. Each basket complete with mounting brackets, 5 front/back dividers and full-length label holders. Add-on units have frames with 1 upright only.  
\* "M" mobile units complete with mobile kit and hardware. 4 - 4" swivel casters, two with brakes.

MODEL #	DESCRIPTION	D x W x H
	Par Wall® Complete Unit	(inches)
PARWALL18	Par Wall® Complete Unit, 6 Baskets	18 x 18 x 74
PARWALL18M	Par Wall® Complete Unit, 6 Baskets, Mobile	26 x 18 x 78
PARWALL18-A	Par Wall® Complete Unit, 6 Baskets, Add-On	18 x 18 x 74
PARWALL18-AM	Par Wall® Complete Unit, 6 Baskets, Add-On, Mobile	26 x 18 x 78
PARWALL36	Par Wall® Complete Unit, 6 Baskets	18 x 36 x 74
PARWALL36M	Par Wall® Complete Unit, 6 Baskets, Mobile	26 x 36 x 78
PARWALL36-A	Par Wall® Complete Unit, 6 Baskets, Add-On	18 x 36 x 74
PARWALL36-AM	Par Wall® Complete Unit, 6 Baskets, Add-On, Mobile	26 x 36 x 78

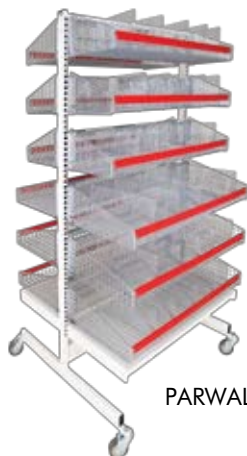

PARWALL36-DBM

### Freestanding Complete Units



PARWALL36M

### 12 Baskets

#### Par Wall® Double-Sided Stationary and Mobile Complete Units:

Complete with 1 double-sided frame, 2 bottom dust shelves, 4-18"D large mesh baskets, 2-18"D fine mesh basket, 6-12"D fine mesh baskets. Each basket complete with mounting brackets, 5 front/back dividers and full-length label holders.

\* "M" mobile units complete with mobile kit and hardware. 4 x 4" swivel casters, two with brakes.

MODEL #	DESCRIPTION	D x W x H
	Par Wall® Complete Unit	(inches)
PARWALL36-DB	Par Wall® Complete Unit, Dbl Sided, 12 Baskets	36 x 18 x 60
PARWALL36-DBM	Par Wall® Complete Unit, Dbl Sided, 12 Baskets, Mobile	40 x 18 x 65

### 7 Baskets

#### Par Wall® Single-Sided Stationary and Mobile Complete Units:

Complete with 1 frame, 1 bottom dust shelf, 2-18"D large mesh baskets, 1-18"D fine mesh basket, 4-12"D fine mesh baskets. Each basket complete with mounting brackets (top basket to have slanted brackets) 5 front/back dividers and full-length label holders. Add-on units have frames with 1 upright only.

\* "M" mobile units complete with mobile kit and hardware. 4 - 4" swivel casters, two with brakes.

MODEL #	DESCRIPTION	D x W x H
	Par Wall® Complete Unit	(inches)
PARWALL187	Par Wall® Complete Unit, 7 Baskets	18 x 18 x 74
PARWALL187M	Par Wall® Complete Unit, 7 Baskets, Mobile	26 x 18 x 78
PARWALL187-A	Par Wall® Complete Unit, 7 Baskets, Add-On	18 x 18 x 74
PARWALL187-AM	Par Wall® Complete Unit, 7 Baskets, Add-On, Mobile	26 x 18 x 78
PARWALL367	Par Wall® Complete Unit, 7 Baskets	18 x 36 x 74
PARWALL367M	Par Wall® Complete Unit, 7 Baskets, Mobile	26 x 36 x 78
PARWALL367-A	Par Wall® Complete Unit, 7 Baskets, Add-On	18 x 36 x 74
PARWALL367-AM	Par Wall® Complete Unit, 7 Baskets, Add-On, Mobile	26 x 36 x 78



PARWALL367

\*\* Mobile Par Wall® Units: Mobile Starter with 1 add-on, max mobile size for cleaning only.



## Par Wall® Baskets and Shelves

Nickel-chrome plated wire. 3/8" square fine mesh (FM). 1" square large mesh. Three HD welded brackets on back for attachment to wall-mount louvered panels. Frame mount baskets require use of PWBRACKET, 1 pair/basket.



PFW1236FM Fine Mesh Basket 12" x 36"

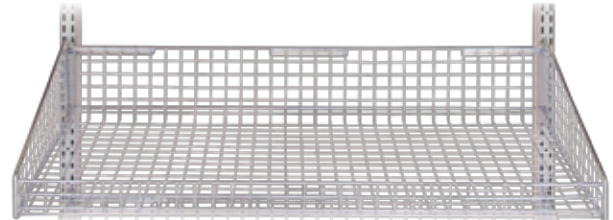

PFW1836 Large Mesh Basket 18" x 36"



PFW1836SL Suture Shelf



PFW1836SH Dust Shelf 18" x 36"

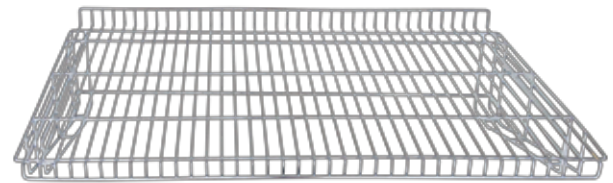

PFW2436 Flat Shelf 24" x 36"

MODEL #	DESCRIPTION	D x W x H (inches)	FRONT LIP (inches)
PFW1218FM	Fine Mesh Basket	12 x 18 x 7.5	2.5 H
PFW1236FM	Fine Mesh Basket	12 x 36 x 7.5	2.5 H
PFW1818	Large Mesh Basket	18 x 18 x 7.5	2.5 H
PFW1818FM	Fine Mesh Basket	18 x 18 x 7.5	2.5 H
PFW1836	Large Mesh Basket	18 x 36 x 7.5	2.5 H
PFW1836FM	Fine Mesh Basket	18 x 36 x 7.5	2.5 H
PFW1836SL	Slanted Suture Shelf	18 x 36 x 11	2.5 H
PFW2436	Flat Wire Shelf	24 x 36 x 2	
PFW1236SH	Dust Shelf White Epoxy - Not for holding stock	12 x 36 x 1	
PFW1836SH	Dust Shelf White Epoxy - Not for holding stock	18 x 36 x 1	
PFW1818SH	Dust Shelf White Epoxy - Not for holding stock	18 x 18 x 1	
PWBRACKET	Brackets (Pair) to Mount - Basket/shelf to frame		
PWBRACKETSL	Brackets (Pair) 3 Position Slant to Mount - Basket/shelf to frame		
PWBRACKETSH	Bracket for Mounting "SH" shelf to louvered panels only		

# Par Wall Dividers and Label Holders

## Front to Back and Subdividers

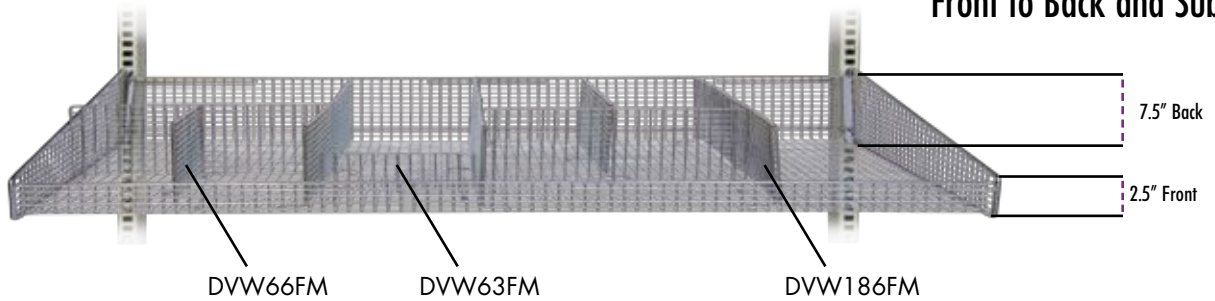

### LEAN Subdividers: Ideal for Twin Bin/Kanban Applications

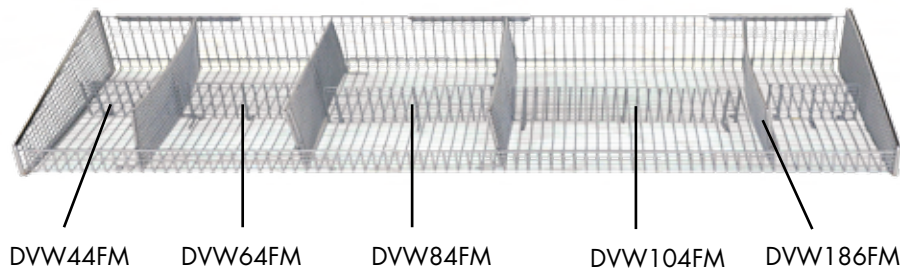

MODEL #	DESCRIPTION	D x H (inches)
	Divider	
DVW126FM	Front/Back Divider	12 x 6
DVW184	Front/Back Divider	18 x 4
DVW186FM	Front/Back Divider	18 x 6
DVW104FM	Lean Subdivider	10 x 4
DVW84FM	Lean Subdivider	8 x 4
DVW64FM	Lean Subdivider	6 x 4
DVW44FM	Lean Subdivider	4 x 4
DVW66FM	Subdivider	6 x 6
DVW63FM	Subdivider	6 x 3

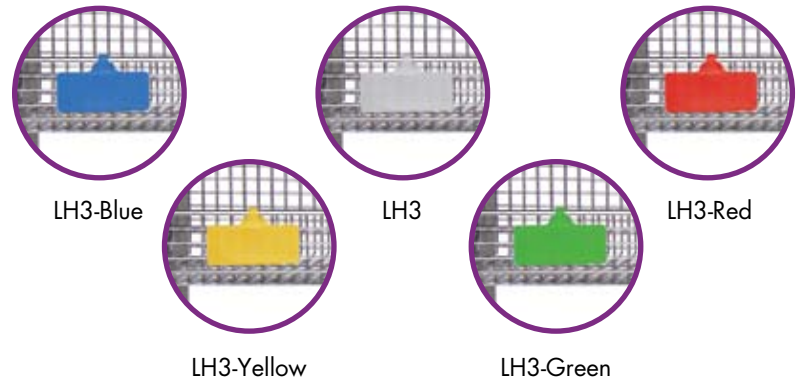

### Par Wall® Tags

MODEL #	DESCRIPTION	W x H (inches)	QTY Bag of
LH3	White Plastic Label Tag	1 x 3	125
LH3-BLUE	Blue Plastic Label Tag	1 x 3	125
LH3-YELLOW	Yellow Plastic Label Tag	1 x 3	125
LH3-RED	Red Plastic Label Tag	1 x 3	125
LH3-GREEN	Green Label Tag	1 x 3	125

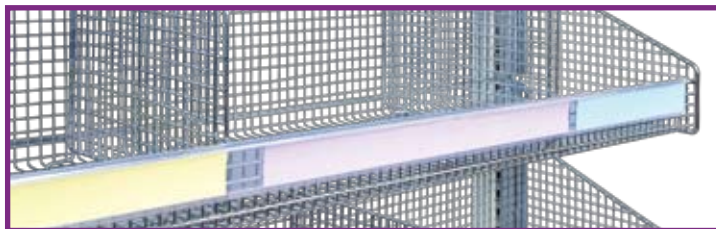

PFLH36CL Clear Label Holder on a 36" W Shelf  
Shown with color inserts for example



PFLH36 Label Holder on a 36" W Shelf

### Par Wall® Label Holders

MODEL #	DESCRIPTION	W x H (inches)
PFLH18	Full-Length Plastic Label Holder, Red	18 x 1
PFLH36	Full-Length Plastic Label Holder, Red	36 x 1
PFLH36CL	Full-Length Plastic Label Holder w/ Pouch, Clear	36 x 1
PFLH18CL	Full-Length Plastic Label Holder w/ Pouch, Clear	18 x 1

## Par Wall® Frames and Accessories



Regular and slanted brackets in use.  
Shown at 30° slope.

**Par Wall® Freestanding Frames:** Heavy Duty epoxy coated steel frame with bracket slots at 1" intervals. Frame legs 17"D (less than the deepest 18" basket) with leveling bolts. Top basket at 64-1/2"H.

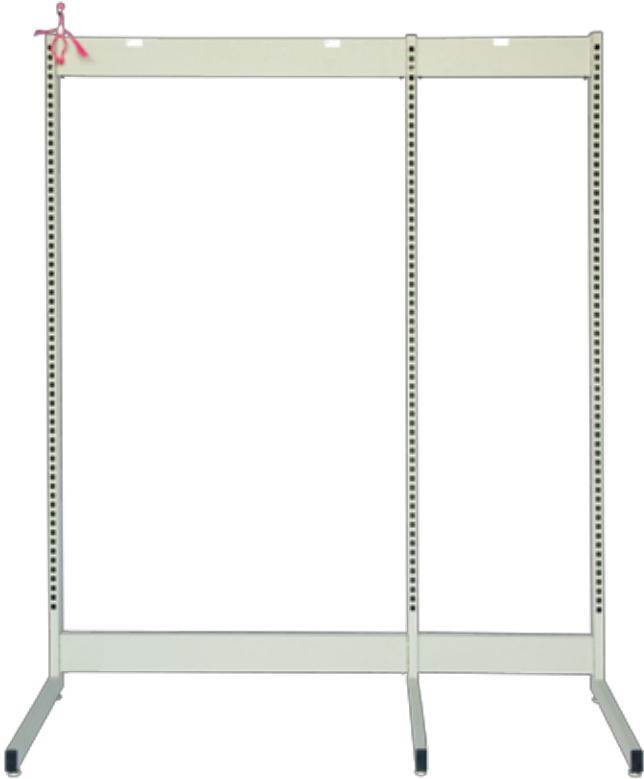

LP3674FSG and LP1874FSG-A

MODEL #	DESCRIPTION	W x H (inches)
LP3674FSG	Starter Frame Unit, Single-Sided	36 x 74
LP3674FSG-A	Add-On Frame Unit, Single-Sided	36 x 74
LP1874FSG	Starter Frame Unit, Single-Sided	18 x 74
LP1874FSG-A	Add-On Frame Unit, Single-Sided	18 x 74
LP3674FDB	Starter Frame Unit, Double-Sided	36 x 74
PWBRACKET*	Shelf Brackets (pair)	
PWBRACKETSL*	Slanted Shelf Brackets (pair). Slant 8°, 10°, 30° slope	
PFWISIS-BRKT	Seismic Bracket for Par Wall® Frame Floor Mount	

\*Brackets need to be ordered separately for each basket/shelf used on a frame.



PFWISIS-BRKT

**Mobile Kits:** Heavy Duty epoxy coated steel bars. 4 - 4" swivel casters, two with brakes. Set includes bars, mounting bolts, mounting nuts and casters.

MODEL #	DESCRIPTION	W x D (inches)
PWSKATE3	Single-Sided Mobile Kit 4" Swivel Casters 2 with Brakes	26 x 1
PWSKATE3DB	Double-Sided Mobile Kit 4" Swivel Casters 2 with Brakes	40 x 1



PWSKATE3



PWSKATE3DB  
in use

**Mobile Kit Units Are For Cleaning Movement Only. Mobile Kits Do Not Make Carts.**



## Par Wall® Panels and Accessories



P3619B Panel Attached to LP3674FSG Panel Using PWBRACKET3619

**Panel Mount Bracket Kits for Frame:** Epoxy coated steel cross frames for mounting louvered panels to freestanding frames. Brackets and hardware (nuts, bolts) included. Panels not included.

\*\*Designed for LogiQuip panels only.\*\*

MODEL #	DESCRIPTION
PWBRACKET1819	Par Wall® Panel/Frame Bracket 18"W (set of 2) for P1819B panel
PWBRACKET1861	Par Wall® Panel/Frame Bracket 18"W (set of 4) for P1861B panel
PWBRACKET3619	Par Wall® Panel/Frame Bracket 36"W (set of 2) for P3619B panel
PWBRACKET3661	Par Wall® Panel/Frame Bracket 36"W (set of 4) for P3661B panel



A Simple Solution for Storing Large, Irregular Shaped Items with Ease

Maximum Storage  
Minimum Footprint

PARWALL36-INST Bulk Instrument Storage for large, odd shaped instruments.

Hooks ordered separately from Page 10.

## Par Wall® Panels and Accessories



P3661B with baskets



P1861B with baskets



P1819B with baskets and hooks

**Wall Mount Panels:** 16 gauge steel, white textured epoxy finish. Baskets mount to louvers via the three welded brackets. No tools required. Mounting bracket required for dust shelf only.

MODEL #	DESCRIPTION	W x H (inches)
	Louvered Panel	
P1819B	Small Louvered Panel	18.5 x 19
P3619B	Medium Louvered Panel	36.5 x 19
P1861B	Tall Narrow Louvered Panel	18.5 x 61
P3661B	Tall Louvered Panel	36.5 x 61
PWBRACKETSH*	Pair of Dust Shelf Brackets	

\*For panel use brackets are only needed for the bottom dust shelf.

### Spikes and Holders for Wall Mount Panel:

All steel fabrication.

MODEL #	DESCRIPTION
BHW	Adjustable Box Holder, Pair
BCH	Catheter Basket, 21" x 4" x 4"
HTH	Horizontal Tape Holder
VTH	Vertical Tape Holder
PWDLSPIKE10	Equipment Spike (10" Dual Light-Duty Rod)
PWHDSPIKE12	Equipment Spike (Heavy Duty 12")
PWHDSPIKE6	Equipment Spike 6" (Heavy Duty)
PWRSPIKE9	Equipment Spike (9" Light Duty Rod)
PWSPIKE12	Equipment Spike 12" Angled (Round)

See page 4 for complete wall units with spikes for crutch/equipment storage.

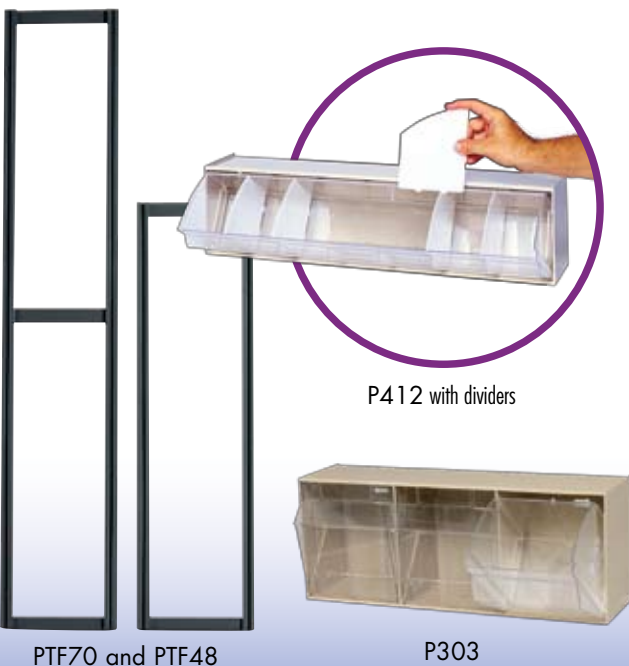
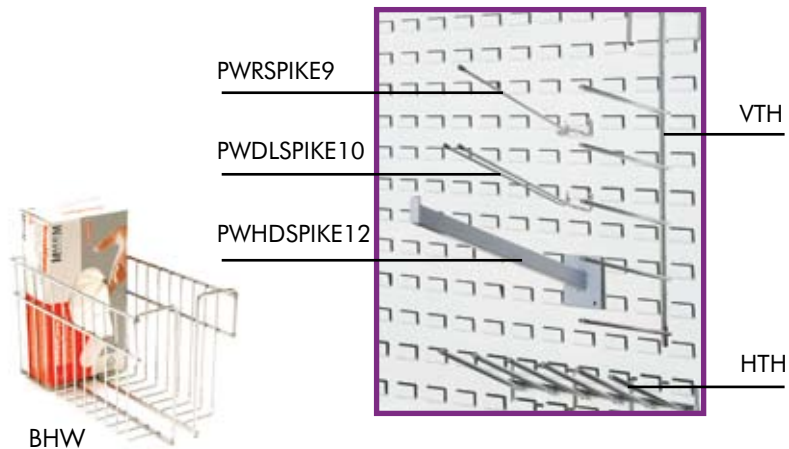

PTF70 and PTF48

P412 with dividers

P303

### Tilt Bins & Panel Brackets:

MODEL #	DESCRIPTION, INDIVIDUAL BIN SIZE	TOTAL UNIT SIZE
	H x D x W, (inches)	O.D. (inches)
P303	3-Bin Tilt Bin. Each Bin, 8.5 x 5.75 x 7.5	8.5 x 5.75 x 22.5
P304	4-Bin Tilt Bin. Each Bin, 7.5 x 5 x 6.5	7.5 x 5 x 26
P305	5-Bin Tilt Bin. Each Bin, 5.75 x 3.75 x 5.25	5.75 x 3.75 x 26.25
P306	6-Bin Tilt Bin. Each Bin, 3.75 x 2.75 x 3.5	3.75 x 2.75 x 21
P309	9-Bin Tilt Bin. Each Bin, 2.25 x 1.75 x 2.5	2.25 x 1.75 x 22.5
P412	Modular Tilt Bin with 5 dividers, 6 x 5.25	6 x 5.25 x 25
PBR	Tilt Bin Bracket to Attach Bin to Panel	
PTF70	Bin Frame 70"H to hold 7-P303, 7-P304 or 10-P305	
PTF48	Bin Frame 48"H to hold 5-P303, 6-P304 or 7-P305	
PDS300	Disk/Screw Set to attach Bin to Frame (2 disks, 2 screws)	
QFS170	Floor Stand for Tilt Bins, Single Sided 70"H	



# Par Stor-III®

## ORGANIZED HIGH-DENSITY STORAGE



Sterile Stores Environment



Small Supply Density



Peel Pouch Use



Clean Supply Storage (Hybrid System)

**Modules or Cart Systems  
Dozens of Customized  
Configurations**

*Keep Loads of Supplies  
in a Small Footprint*

**Organized &  
Compartmentalized.**

*All Vertical Space is Used.*

*Wire Minimizes Dust.*



# Par Stor-III<sup>®</sup>



Red Safety Stop  
locks slanted baskets down TIGHT.

ParStor<sup>®</sup>-III  
Complete Module as Shown

BTO-III - Top Shelf

SLT-III - Slanted Slide

Sloped B3-III  
3" Wire Basket on 4" Slant

B5-III - 5" Wire Basket

SLFR-III - Wire Frame for Tub

T5-III - 5" Tub, Plastic

SL-III - Extension Slide

FR68-III - Frame

B8-III - 8" Wire Basket

Insert-III - Bottom Dust Cover

PSCASTB4 - 4" Caster w/ Brake

19 1/2"W

24"D

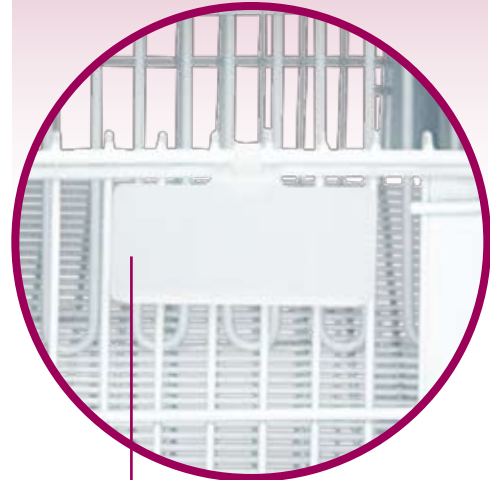

LH-3 Label Holder  
White, Red, Yellow, Blue, Green  
(See Page 7)

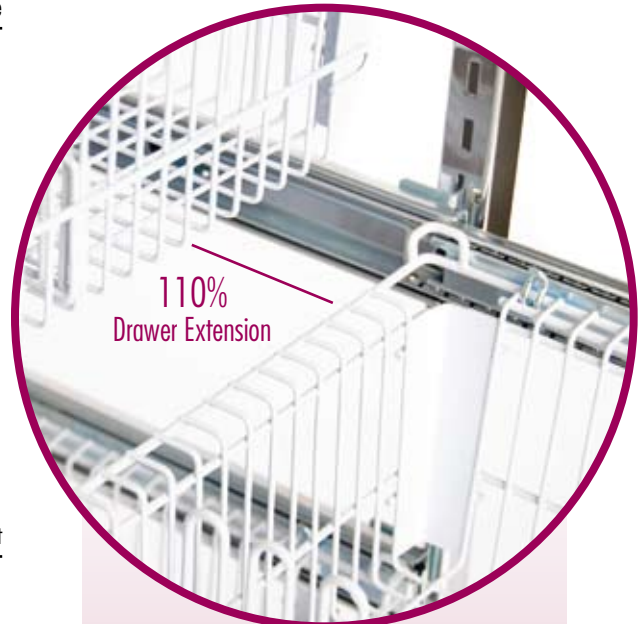

110%  
Drawer Extension

# 110% Accessible

## Par Stor-III®



PAR STOR-III

**Par Stor-III® Complete Standard Module:** Complete with 2 frames, 4 cross bars, top wire basket, and from top: 1-3"H basket on sloping slides with safety stop with 2 long and 2 short dividers; 5-5"H baskets each with 1 long and 2 short dividers; 1-5"H drawer with 2 long and 2 short dividers; 1-8"H basket with 1 long and 1 short divider; all on full-extension slides, bottom dust cover and 4-4"H casters, 2 with brakes, 25 #LH3 label tags included.

MODEL #	DESCRIPTION	D x W x H (overall)
	Par Stor® Complete Unit	(inches)
PAR STOR-III	Par Stor® Complete Unit, Starter, 7 Baskets, 1 Drawer	24 x 20 x 75
PARST ADD-III	Par Stor® Complete Unit, Add-On, 7 Baskets, 1 Drawer	26 x 18 x 75

\* Add-On Units have all above components except with 1 frame only.

\*\* Units can be customized using components listed on page 16.

**Par Stor-III® Wide Complete Standard Module:** Complete with 2 frames, 4 cross bars, top wire basket, and 6-8"H (23.75"D x 46"W) baskets on ultra-heavy-duty slides. 2 short dividers per basket and 50 model #LH3 label tags. Bottom dust cover and floor anchor kit included in package.

MODEL #	DESCRIPTION	D x W x H (overall)
	Par Stor® Complete Unit	(inches)
PAR STOR48-III	Par Stor® Complete Unit, Wide Unit, 6 Baskets	24 x 48 x 72

\* Add-On Units not available due to width of unit.

\*\* Unit stability requires anchor kit #SIS-PLT1.



PARSTOR48 with SIS-PLT1 Anchor Plate  
Only 4 baskets shown. Bottom dust cover not pictured.



PS-CSSS1-III Complete Unit

PS-CSSS1A-III Add-on Unit

### Par Stor® Container Storage Module:

Complete with 2 frames, 4 cross bars, 7 wire shelves on slides. Bottom dust cover and 4 - 4" swivel casters, two with brakes.

### Par Stor® Peel Pouch Storage Module:

Complete with 2 frames, 4 cross bars, 7 - 5"H wire baskets on full extension slides, 36 short dividers, 10 long dividers, 168 label tags, bottom dust cover and 4"H casters, two with brakes.

PSIR-III Complete Unit

PSIRA-III Add-on Unit

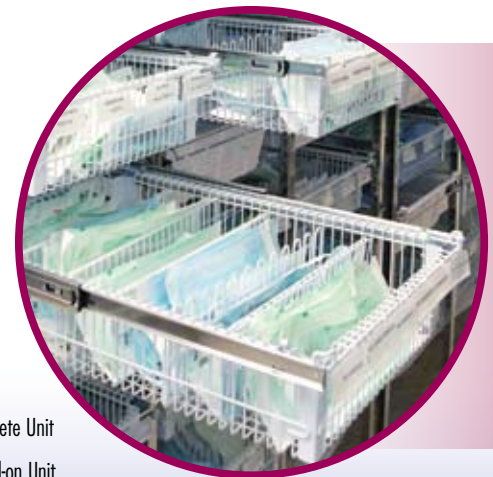

# Par Stor-III®



310-III Complete Cart Shown with Optional Stainless Steel Worktop

### Open Par Carts:

- Designed for transport of sterile supplies. Holds standard Par Stor 16" x 24" baskets and tubs.
- Frame units do not include tubs or baskets. Accessories mounted on full-extension slides.
- All-welded 1" square tubular epoxy-coated steel frame.
- Sturdy base with solid shelf insert for infection control.
- 5" quiet poly swivel casters. Standard donut bumpers on corners.
- Accessories include dividers, label tags, nylon covers and solid stainless tops.

MODEL #	DESCRIPTION	D x W x H (overall)	SLOTS	MODEL #	TOP MODEL #
	Par Cart Frame	(inches)	# of	Cart Cover	Solid Stainless
300-III	Single Short Par Cart Frame	29.5 x 25 x 43	30	PNC300-III	Top-Single-III
320-III	Double Short Par Cart Frame	29.5 x 44 x 43	60	PNC320-III	Top-Double-III
500-III	Single Medium Par Cart Frame	29.5 x 25 x 58.5	46	PNC500-III	Top-Single-III
520-III	Double Medium Par Cart Frame	29.5 x 44 x 58.5	92	PNC520-III	Top-Double-III
600-III	Single Tall Par Cart Frame	29.5 x 25 x 74.5	62	PNC600-III	Top-Single-III
620-III	Double Tall Par Cart Frame	29.5 x 44 x 74.5	124	PNC620-III	Top-Double-III
630-III	Triple Tall Par Cart Frame	29.5 x 65 x 74.5	186	PNC630-III	Top-Triple-III

### Build Your Own Par Cart:

- Refer to the number of available slots in the table above.
- Table below indicates how many slots each basket/tub/shelf occupies.

DESCRIPTION	SLOTS	DESCRIPTION	SLOTS
	# of		# of
3" Basket	4	3" Tub	5
5" Basket	6	5" Tub	7
8" Basket	9	8" Tub	10
Slanted 3" Basket or Tub	7	Chrome Wire Shelf	2

\* See Accessories on page 16.



6200-III



PS620-III Container Cart



505-III Complete Cart

### "Complete" Par Carts:

- Our most popular configurations in ready-to-order format.

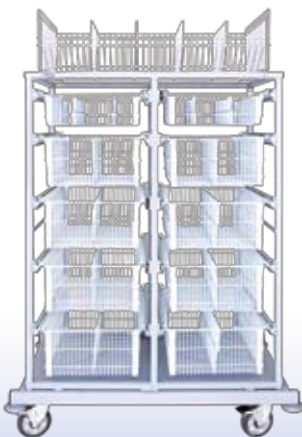

520IV-III IV Cart

MODEL #	DESCRIPTION	D x W x H (O.D.)
		(inches)
310-III	Preconfigured single short par cart with stainless steel top. 1 - 3", 2 - 5", 1 - 8" baskets	29.5 x 25 x 43
505-III	Preconfigured single medium par cart. 1 - 3", 4 - 5", 1 - 8" baskets	29.5 x 25 x 58.5
605-III	Preconfigured single tall par cart. 1 - 3", 6 - 5" baskets	29.5 x 25 x 74.5
500IV-III	IV Cart. 1 - 5", 2 each long /short divider, 4 - 8", 2 long divider each	29.5 x 25 x 58.5
500IV-III-KP	IV Cart. 4 - 8" baskets each with 2 long dividers/basket	29.5 x 25 x 58.5
520IV-III	2 - 5", 2 long dividers each, 8 - 8", 1 long divider each	29.5 x 44 x 58.5
520IV-III-KP	8 - 8" baskets each with 2 long dividers. 24 each LH-3 label tags	29.5 x 44 x 58.5
PS620-III	14 each waterfall-edge chrome wire shelves	29.5 x 44 x 74.5
6200-III	7 each waterfall-edge chrome wire shelves and 7 - 5" baskets	29.5 x 44 x 74.5



## Par Stor-III®

### Enclosed Par Carts:

- Transport sterile supplies in an enclosed cart. Ideal for non-dedicated delivery systems.
- Holds standard Par Stor 16" x 24" baskets and tubs.
- Units do not include tubs or baskets. Accessories mounted on full-extension slides.
- All-welded 1" square tubular epoxy-coated steel frame.
- Frame enclosed in blue epoxy-coated steel.
- 3/8" plastic clear door with 3 hospital-grade hinges and chrome handle.
- Sturdy base with solid shelf insert for infection control.
- 5" quiet poly swivel casters. Standard donut bumpers on corners.
- Accessories include dividers and label tags. See page 16.

MODEL #	DESCRIPTION	D x W x H (overall)	SLOTS
	Par Cart Frame	(inches)	# of
500EN-III	Single Enclosed Medium Par Cart Frame	29.5 x 25 x 58.5	46
520EN-III	Double Enclosed Medium Par Cart Frame	29.5 x 44 x 58.5	92
600EN-III	Single Enclosed Tall Par Cart Frame	29.5 x 25 x 74.5	62
620EN-III	Double Enclosed Tall Par Cart Frame	29.5 x 44 x 74.5	124



620EN-III w/ Example Basket Set

### Build Your Own Enclosed Par Cart:

- Refer to the number of available slots in the table above.
- Table below indicates how many slots each basket/tub/shelf occupies.

DESCRIPTION	SLOTS	DESCRIPTION	SLOTS
	# of Occupied		# of Occupied
3" Basket	4	3" Tub	5
5" Basket	6	5" Tub	7
8" Basket	9	8" Tub	10
Slanted 3" Basket or Tub	7	Chrome Wire Shelf	2

\* See Accessories on page 16.

### "Complete" Enclosed Par Carts:

- Our most popular configurations in ready-to-order format.



500EN-III w/ Example Basket Set

MODEL #	DESCRIPTION	D x W x H (O.D.)
		(inches)
505EN-III	Preconfigured single medium par cart. 1 - 3", 4 - 5", 1 - 8" baskets	29.5 x 25 x 58.5
605EN-III	Preconfigured single tall par cart. 1 - 3", 6 - 5" baskets	29.5 x 25 x 74.5
500IV-EN-III	IV Cart. 1 - 5", 2 each long /short divider, 4 - 8", 2 long divider each	29.5 x 25 x 58.5
500IV-EN-II-KP	IV Cart. 4 - 8" baskets each with 2 long dividers/basket	29.5 x 25 x 58.5
520IV-EN-III	2 - 5", 2 long dividers each, 8 - 8", 1 long divider each	29.5 x 44 x 58.5
520IV-EN-II-KP	8 - 8" baskets each with 2 long dividers. 24 each LH-3 label tags	29.5 x 44 x 58.5
6200CONT-EN-III	14 each waterfall-edge chrome wire shelves	29.5 x 44 x 74.5
6200ORTH-EN-III	7 each waterfall-edge chrome wire shelves and 7 - 5" baskets	29.5 x 44 x 74.5

# Par Stor-III®

All Par Stor-III® baskets, shelves & tubs are fully interchangeable with our LogiCell® carts

**MODULAR.  
INTERCHANGEABLE.  
VERSATILE.**



Ultra modular for maximum capacity and versatility

## Par Stor-III® Shelves & Dividers

MODEL #	DESCRIPTION	SIZE	WT.
FR68-III	Frame 68"H, Chrome	24"L x 68"H	12
CB18JB-III	Cross Bar 14", Chrome	14"L	1
INSERT-III	Poly Base Dust Cover	22"L x 14"W	1
B3-III	Wire Basket, 3", White	22"L x 14"W x 3"H	4
B3DL-III	Wire Divider, Long, White	22"L x 3"H	1/2
B3DS-III	Wire Divider, Short, White	14"L x 3"H	1/2
B5-III	Wire Basket, 5", White	22"L x 14"W x 5"H	5
B5DL-III	Wire Divider, Long, White	22"L x 5"H	1/2
B5DS-III	Wire Divider, Short, White	14"L x 5"H	1/2
B8-III	Wire Basket, 8", White	22"L x 14"W x 8"H	6
B8DL-III	Wire Divider, Long, White	22"L x 8"H	1/2
B8DS-III	Wire Divider, Short, White	14"L x 8"H	1/2
T3-III	Poly Drawer, 3", White	22"L x 14"W x 3"H	1 1/2
T3DL-III	Poly Divider, Long, White	22"L x 3"H	1/4
T3DS-III	Poly Divider, Short, White	14"L x 3"H	1/4
T5-III	Poly Drawer, 5", White	22"L x 14"W x 5"H	2
T5DL-III	Poly Divider, Long, White	22"L x 5"H	1/4
T5DS-III	Poly Divider, Short, White	14"L x 5"H	1/4
T8-III	Poly Drawer, 8", White	22"L x 14"W x 8"H	3
T8DL-III	Poly Divider, Long, White	22"L x 8"H	1/4
T8DS-III	Poly Divider, Short, White	14"L x 8"H	1/4
SLFR-III	Frame for Tubs	22"L x 14"H	1
SL-III	Full Extension Slide, Pair	22"L	10
SLT-III	Full Ext. Slide, Slant Pair	22"L	10
BTO-III	Top Shelf, Wire, Open, Flat Front	22"L x 18"W x 4"H	6
TU162ORPS-III	Wire Shelf, Chrome	24"L x 14"W	3
TTU162ORPS-III	Wire Shelf, White	24"L x 14"W	3
LH3	3" Bin Tag, Whit, Yel, Rd, Grn, Bl	3"L x 1"H	
PSCAST4	Caster For "FR" Frames	4"	1/2
PSCASTB4	Caster With Brake	4"	1/2

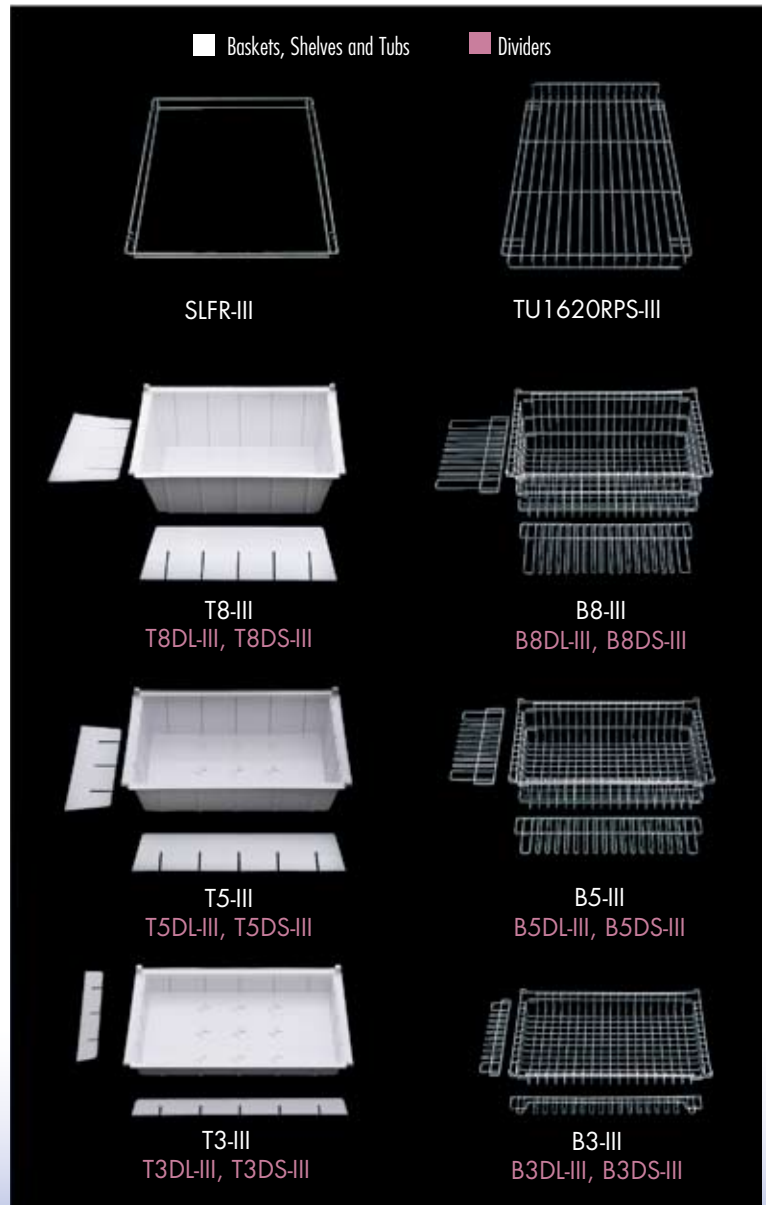

## LQ Wire Shelving and Carts

LogiQuip has every wire shelving configuration imaginable. From standard flat-shelf wire carts to premium dolly-base transport carts and high-density floor track systems.



Sutures on Flat Wire Shelving with Seismic Bracing (page 33)



Corner Shelving Units (page 44)



Single Sided Suture Carts (page 42)



Par Wall (pages 4-10) and AF-Carts (pages 40-41)

### Wire Section Table of Contents

Static wire units - 4 shelves .....	18
Static wire units - 5 shelves .....	19
Mobile wire carts - 4 shelves .....	20
Mobile wire carts - 5 shelves .....	21
Mobile enclosed wire- 4 shelves .....	22
Mobile enclosed wire- 5 shelves .....	23
Open dolly carts - 4 shelves .....	24
Open dolly carts - 5 shelves .....	25
Enclosed dolly base carts - 4 shelves .....	26
Enclosed dolly base carts - 5 shelves .....	27
Shelves and posts .....	28
Casters and dollies .....	29
Enclosure panels and ledges .....	30
Baskets/tubs dividers .....	31
Handles, frames, dunnage racks .....	32
Seismic foot plates/braces and clamps .....	33
Label holders .....	34
Dividers/Rods and Tabs .....	35
Cart covers .....	36-37
Floor Track System .....	38-39
IV/Basket Carts - AF-style .....	40-42
Suture/Lens Implant Carts .....	42-43
Corner Shelving Units .....	44
TSUN Premium Wire Carts .....	45
Plastic Shelf Covers .....	46
Wall-mount shelving .....	47



# LQ Wire Shelving and Carts

## 4-Shelf Open Static Wire Shelving 63"H

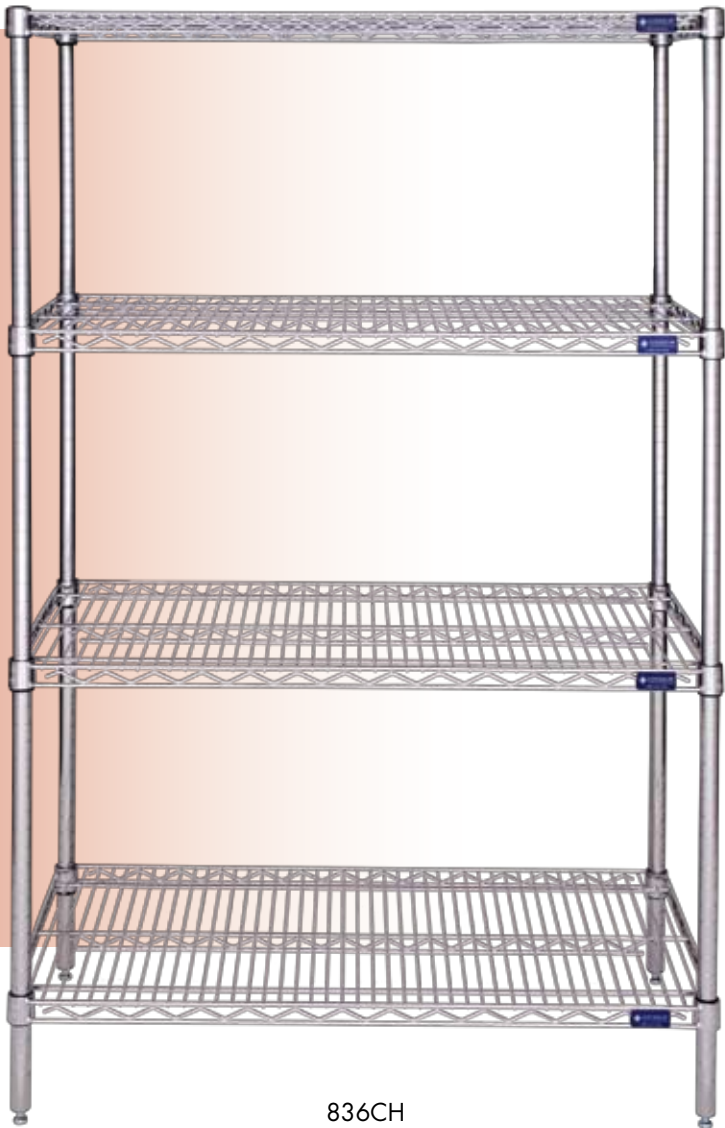

836CH

### Standard Unit Components:

- 4 each 63"H posts with caps and leveling feet.
- 4 wire shelves with split sleeves.

### Add-On Unit Components:

- 2 each 63"H posts with caps and leveling feet.
- 4 wire shelves with split sleeves and 8 S-hooks (2 per shelf).

### "Complete" Units Accessories (-CL):

- 4 full-length 3-position label holders.
- Bottom shelf cover, solid, flat, poly.

### Weight Capacities:

- Up to 48": 800 lbs. per shelf.
- Over 48": 600 lbs. per shelf.

### Other Standard Sizes Available:

- Depths: 14" and 21"
- Widths: 24", 30", 42" and 54"
- Posts: 54", 74" and 86"

## 4-Shelf Standard Starter Unit

D x W x H	WT.	CHROME PLUS	DURO SEAL
(inches)	(lbs.)	Part #	Part #
18 x 36 x 63	53	836CH	836PW
18 x 48 x 63	63	856CH	856PW
18 x 60 x 63	82	866CH	866PW
18 x 72 x 63	94	876CH	876PW
24 x 36 x 63	65	436CH	436PW
24 x 48 x 63	79	456CH	456PW
24 x 60 x 63	98	466CH	466PW
24 x 72 x 63	120	476CH	476PW

## 4-Shelf Standard Add-On Unit

D x W x H	WT.	CHROME PLUS	DURO SEAL
(inches)	(lbs.)	Part #	Part #
18 x 36 x 63	46	A836CH	A836PW
18 x 48 x 63	56	A856CH	A856PW
18 x 60 x 63	75	A866CH	A866PW
18 x 72 x 63	89	A876CH	A876PW
24 x 36 x 63	58	A436CH	A436PW
24 x 48 x 63	72	A456CH	A456PW
24 x 60 x 63	91	A466CH	A466PW
24 x 72 x 63	113	A476CH	A476PW

## 4-Shelf "Complete" Starter Unit

D x W x H	WT.	CHROME PLUS	DURO SEAL
(inches)	(lbs.)	Part #	Part #
18 x 36 x 63	58	836CH-CL	836PW-CL
18 x 48 x 63	68	856CH-CL	856PW-CL
18 x 60 x 63	87	866CH-CL	866PW-CL
18 x 72 x 63	98	876CH-CL	876PW-CL
24 x 36 x 63	70	436CH-CL	436PW-CL
24 x 48 x 63	84	456CH-CL	456PW-CL
24 x 60 x 63	102	466CH-CL	466PW-CL
24 x 72 x 63	125	476CH-CL	476PW-CL

## 4-Shelf "Complete" Add-On Unit

D x W x H	WT.	CHROME PLUS	DURO SEAL
(inches)	(lbs.)	Part #	Part #
18 x 36 x 63	51	A836CH-CL	A836PW-CL
18 x 48 x 63	61	A856CH-CL	A856PW-CL
18 x 60 x 63	80	A866CH-CL	A866PW-CL
18 x 72 x 63	94	A876CH-CL	A876PW-CL
24 x 36 x 63	63	A436CH-CL	A436PW-CL
24 x 48 x 63	77	A456CH-CL	A456PW-CL
24 x 60 x 63	96	A466CH-CL	A466PW-CL
24 x 72 x 63	118	A476CH-CL	A476PW-CL

## LQ Wire Shelving and Carts

### 5-Shelf Standard Starter Unit

D x W x H	WT.	CHROME PLUS	DURO SEAL
(inches)	(lbs.)	Part #	Part #
18 x 36 x 74	65	835CH	835PW
18 x 48 x 74	78	855CH	855PW
18 x 60 x 74	102	865CH	865PW
18 x 72 x 74	117	875CH	875PW
24 x 36 x 74	81	435CH	435PW
24 x 48 x 74	98	455CH	455PW
24 x 60 x 74	122	465CH	465PW
24 x 72 x 74	149	475CH	475PW

### 5-Shelf Standard Add-On Unit

D x W x H	WT.	CHROME PLUS	DURO SEAL
(inches)	(lbs.)	Part #	Part #
18 x 36 x 74	57	A835CH	A835PW
18 x 48 x 74	70	A855CH	A855PW
18 x 60 x 74	93	A865CH	A865PW
18 x 72 x 74	108	A875CH	A875PW
24 x 36 x 74	73	A435CH	A435PW
24 x 48 x 74	90	A455CH	A455PW
24 x 60 x 74	113	A465CH	A465PW
24 x 72 x 74	141	A475CH	A475PW

### 5-Shelf "Complete" Starter Unit

D x W x H	WT.	CHROME PLUS	DURO SEAL
(inches)	(lbs.)	Part #	Part #
18 x 36 x 74	70	835CH-CL	835PW-CL
18 x 48 x 74	83	855CH-CL	855PW-CL
18 x 60 x 74	107	865CH-CL	865PW-CL
18 x 72 x 74	122	875CH-CL	875PW-CL
24 x 36 x 74	86	435CH-CL	435PW-CL
24 x 48 x 74	103	455CH-CL	455PW-CL
24 x 60 x 74	127	465CH-CL	465PW-CL
24 x 72 x 74	155	475CH-CL	475PW-CL

### 5-Shelf "Complete" Add-On Unit

D x W x H	WT.	CHROME PLUS	DURO SEAL
(inches)	(lbs.)	Part #	Part #
18 x 36 x 74	62	A835CH-CL	A835PW-CL
18 x 48 x 74	75	A855CH-CL	A855PW-CL
18 x 60 x 74	98	A865CH-CL	A865PW-CL
18 x 72 x 74	113	A875CH-CL	A875PW-CL
24 x 36 x 74	78	A435CH-CL	A435PW-CL
24 x 48 x 74	95	A455CH-CL	A455PW-CL
24 x 60 x 74	118	A465CH-CL	A465PW-CL
24 x 72 x 74	146	A475CH-CL	A475PW-CL

### 5-Shelf Open Static Wire Shelving 74"H

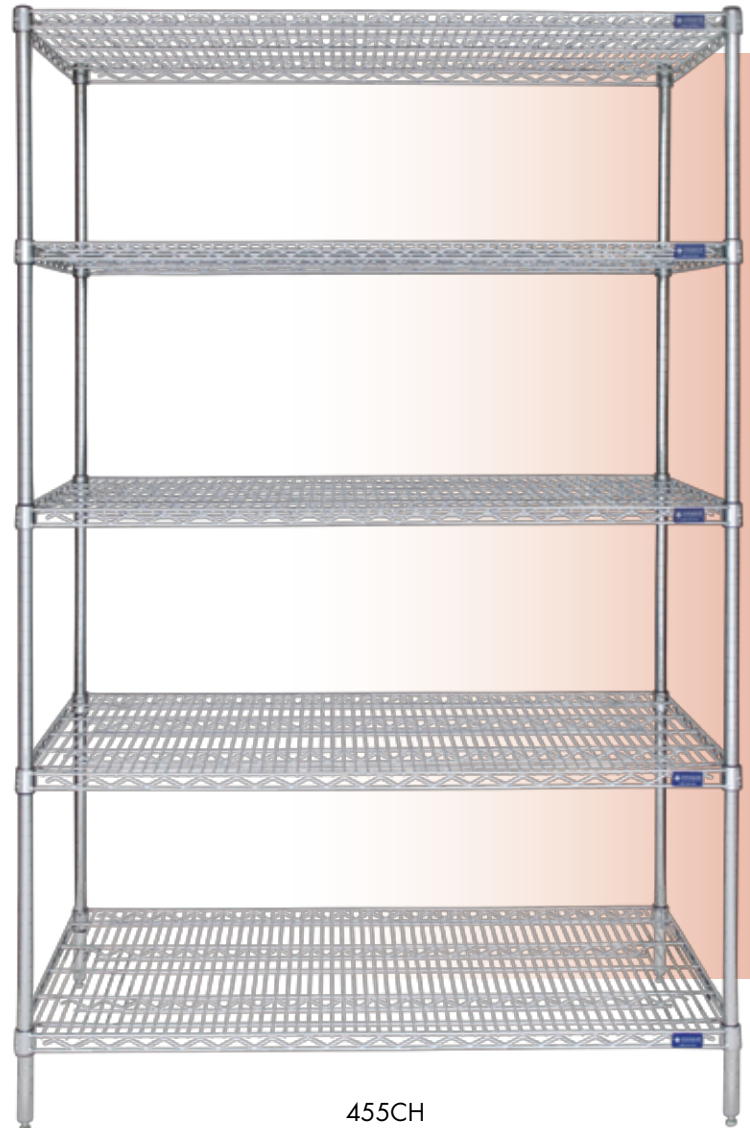

455CH

#### Standard Unit Components:

- 4 each 74"H posts with caps and leveling feet.
- 5 wire shelves with split sleeves.

#### Add-On Unit Components:

- 2 each 74"H posts with caps and leveling feet.
- 5 wire shelves with split sleeves and 10 S-hooks (2 per shelf).

#### "Complete" Units Accessories (-CL):

- 5 full-length 3-position label holder.
- Bottom shelf cover, solid, flat, poly.

#### Weight Capacities:

- Up to 48": 800 lbs. per shelf.
- Over 48": 600 lbs. per shelf.

#### Other Standard Sizes Available:

- Depths: 14" and 21"
- Widths: 24", 30", 42" and 54"
- Posts: 54", 63" and 86"

## LQ Wire Shelving and Carts

### 4-Shelf Open Mobile Wire Shelving 69"H

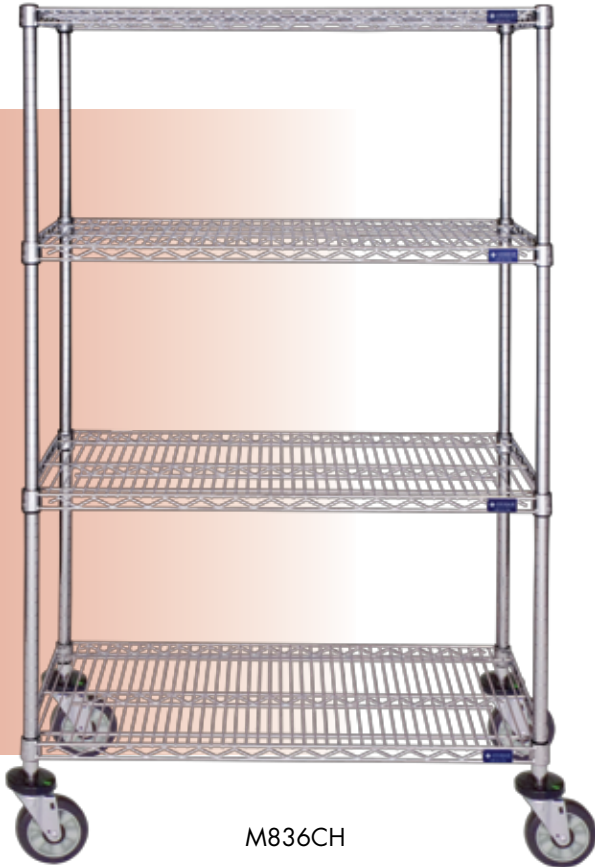

M836CH

**4-Shelf "Open Braking Complete" Units** with 4 Swivel Casters (2 with brakes), 1 solid bottom shelf cover and 4 full-length 3-position label holders.

D x W x H	WT.	CHROME PLUS	DURO SEAL
(inches)	(lbs.)	Part #	Part #
18 x 36 x 69	65	MB836CH-CL	MB836PW-CL
18 x 48 x 69	77	MB856CH-CL	MB856PW-CL
18 x 60 x 69	93	MB866CH-CL	MB866PW-CL
18 x 72 x 69	97	MB876CH-CL	MB876PW-CL
24 x 36 x 69	81	MB436CH-CL	MB436PW-CL
24 x 48 x 69	97	MB456CH-CL	MB456PW-CL
24 x 60 x 69	117	MB466CH-CL	MB466PW-CL
24 x 72 x 69	123	MB476CH-CL	MB476PW-CL

**Standard Units Include:**

- 4 posts 63"H.
- 4 wire shelves with split sleeves.
- 5" swivel non-marking polyurethane casters.
- Donut bumpers.

**"Complete" Units Accessories (-CL):**

- 4 full-length 3-position label holders.
- Bottom shelf cover, solid, flat, poly.

**Weight Capacity:**

- 5" casters. 250 lbs. capacity each.
- Total cart 750 lbs. capacity.

**4-Shelf "Open Standard" Units** with 4 Swivel Casters.

D x W x H	WT.	CHROME PLUS	DURO SEAL
(inches)	(lbs.)	Part #	Part #
18 x 36 x 69	60	M836CH	M836PW
18 x 48 x 69	72	M856CH	M856PW
18 x 60 x 69	88	M866CH	M866PW
18 x 72 x 69	92	M876CH	M876PW
24 x 36 x 69	76	M436CH	M436PW
24 x 48 x 69	92	M456CH	M456PW
24 x 60 x 69	112	M466CH	M466PW
24 x 72 x 69	118	M476CH	M476PW

**4-Shelf "Open Braking" Units** with 4 Swivel Casters (2 with brakes).

D x W x H	WT.	CHROME PLUS	DURO SEAL
(inches)	(lbs.)	Part #	Part #
18 x 36 x 69	60	MB836CH	MB836PW
18 x 48 x 69	72	MB856CH	MB856PW
18 x 60 x 69	88	MB866CH	MB866PW
18 x 72 x 69	82	MB876CH	MB876PW
24 x 36 x 69	76	MB436CH	MB436PW
24 x 48 x 69	92	MB456CH	MB456PW
24 x 60 x 69	112	MB466CH	MB466PW
24 x 72 x 69	118	MB476CH	MB476PW

**4-Shelf "Open Standard Complete" Units** with 4 Swivel Casters, 1 solid bottom shelf cover and 4 full-length, 3-position label holders.

D x W x H	WT.	CHROME PLUS	DURO SEAL
(inches)	(lbs.)	Part #	Part #
18 x 36 x 69	65	M836CH-CL	M836PW-CL
18 x 48 x 69	77	M856CH-CL	M856PW-CL
18 x 60 x 69	93	M866CH-CL	M866PW-CL
18 x 72 x 69	97	M876CH-CL	M876PW-CL
24 x 36 x 69	81	M436CH-CL	M436PW-CL
24 x 48 x 69	97	M456CH-CL	M456PW-CL
24 x 60 x 69	117	M466CH-CL	M466PW-CL
24 x 72 x 69	123	M476CH-CL	M476PW-CL

**Other Standard Sizes Available:**

- Depths: 14" and 21"
- Widths: 24", 30", 42" and 54"
- Posts: 54", 74" and 86"



## LQ Wire Shelving and Carts

### 5-Shelf Open Mobile Wire Shelving 80"H

**5-Shelf "Open Standard" Units** with 4 Swivel Casters.

D x W x H	WT.	CHROME PLUS	DURO SEAL
(inches)	(lbs.)	Part #	Part #
18 x 36 x 69	70	M835CH	M835CH
18 x 48 x 69	84	M855CH	M855CH
18 x 60 x 69	105	M865CH	M865CH
18 x 72 x 69	112	M875CH	M875CH
24 x 36 x 69	89	M435CH	M435CH
24 x 48 x 69	108	M455CH	M455CH
24 x 60 x 69	133	M465CH	M465CH
24 x 72 x 69	144	M475CH	M475CH

**5-Shelf "Open Braking" Units** with 4 Swivel Casters (2 with brakes).

D x W x H	WT.	CHROME PLUS	DURO SEAL
(inches)	(lbs.)	Part #	Part #
18 x 36 x 80	70	MB835CH	MB835PW
18 x 48 x 80	84	MB855CH	MB855PW
18 x 60 x 80	105	MB865CH	MB865PW
18 x 72 x 80	112	MB875CH	MB875PW
24 x 36 x 80	89	MB435CH	MB435PW
24 x 48 x 80	108	MB455CH	MB455PW
24 x 60 x 80	133	MB465CH	MB465PW
24 x 72 x 80	144	MB475CH	MB475PW

**5-Shelf "Open Standard Complete" Units** with 4 Swivel Casters, 1 solid bottom shelf cover and 5 full-length, 3-position label holders.

D x W x H	WT.	CHROME PLUS	DURO SEAL
(inches)	(lbs.)	Part #	Part #
18 x 36 x 80	75	M835CH-CL	M835PW-CL
18 x 48 x 80	89	M855CH-CL	M855PW-CL
18 x 60 x 80	110	M865CH-CL	M865PW-CL
18 x 72 x 80	117	M875CH-CL	M875PW-CL
24 x 36 x 80	94	M435CH-CL	M435PW-CL
24 x 48 x 80	113	M455CH-CL	M455PW-CL
24 x 60 x 80	138	M465CH-CL	M465PW-CL
24 x 72 x 80	149	M475CH-CL	M475PW-CL

#### Standard Unit Components:

- 4 each 74"H posts.
- 5 wire shelves with split sleeves.
- 5" swivel non-marking polyurethane casters.
- Donut bumpers.

#### "Complete" Units Accessories (-CL):

- 5 full-length 3-position label holders.
- Bottom shelf cover, solid, flat, poly.

#### Weight Capacity:

- 5" casters. 250 lbs. capacity each.  
Total cart 750 lbs. capacity.

#### Other Standard Sizes Available:

- Depths: 14" and 21"
- Widths: 24", 30", 42" and 54"
- Posts: 54", 63" and 86"

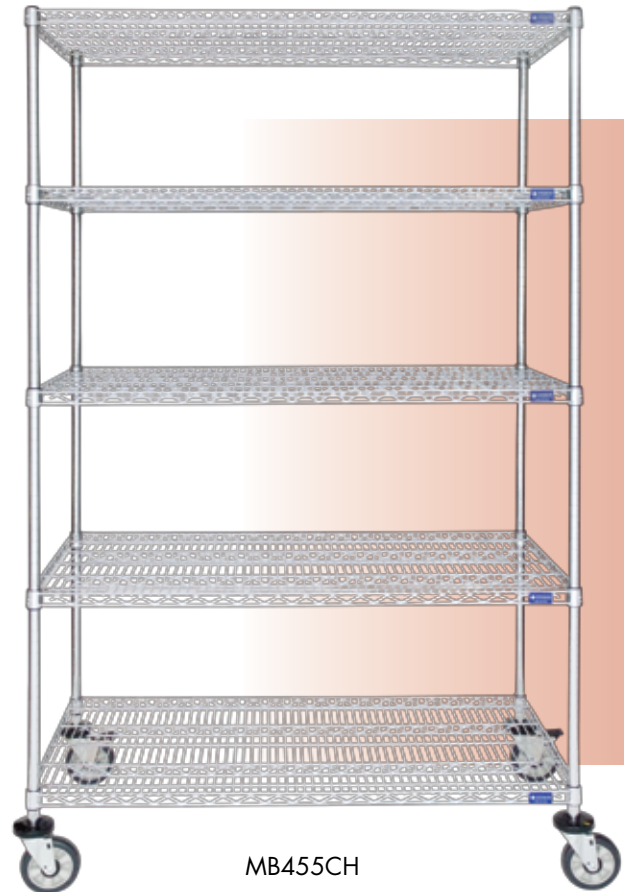

MB455CH

**5-Shelf "Open Braking Complete" Units** with 4 Swivel Casters (2 with brakes), 1 solid bottom shelf cover and 5 full-length 3-position label holders.

D x W x H	WT.	CHROME PLUS	DURO SEAL
(inches)	(lbs.)	Part #	Part #
18 x 36 x 80	75	MB835CH-CL	MB835PW-CL
18 x 48 x 80	89	MB855CH-CL	MB855PW-CL
18 x 60 x 80	110	MB865CH-CL	MB865PW-CL
18 x 72 x 80	117	MB875CH-CL	MB875PW-CL
24 x 36 x 80	94	MB435CH-CL	MB435PW-CL
24 x 48 x 80	113	MB455CH-CL	MB455PW-CL
24 x 60 x 80	138	MB465CH-CL	MB465PW-CL
24 x 72 x 80	149	MB475CH-CL	MB475PW-CL

# LQ Wire Shelving and Carts

## 4-Shelf Enclosed Mobile Wire Shelving 69”H

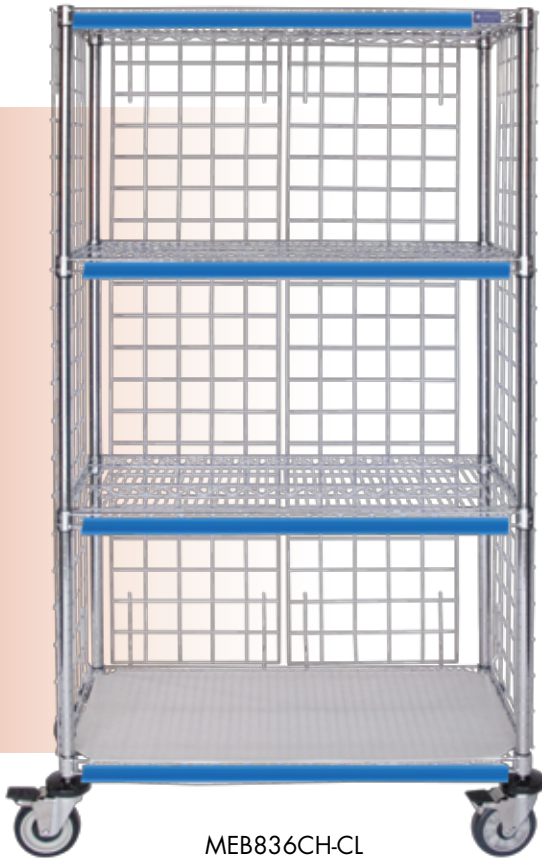

MEB836CH-CL

**4-Shelf “Enclosed Braking Complete” Units** with 4 Swivel Casters (2 with brakes), 1 solid bottom shelf cover and 4 full-length 3-position label holders.

D x W x H (inches)	WT. (lbs.)	CHROME PLUS Part #	DURO SEAL Part #
18 x 36 x 69	111	MEB836CH-CL	MEB836PW-CL
18 x 48 x 69	116	MEB856CH-CL	MEB856PW-CL
18 x 60 x 69	138	MEB866CH-CL	MEB866PW-CL
18 x 72 x 69	147	MEB876CH-CL	MEB876PW-CL
24 x 36 x 69	117	MEB436CH-CL	MEB436PW-CL
24 x 48 x 69	140	MEB456CH-CL	MEB456PW-CL
24 x 60 x 69	166	MEB466CH-CL	MEB466PW-CL
24 x 72 x 69	177	MEB476CH-CL	MEB476PW-CL

**Standard Units Include:**

- 4 posts 63”H.
- 4 wire shelves with split sleeves.
- 3” x 3” mesh enclosure panels on side and back.
- 5” swivel non-marking polyurethane casters.
- Donut bumpers.

**“Complete” Units Accessories (-CL):**

- 4 full-length 3-position label holders.
- Bottom shelf cover, solid, flat, poly.

**Weight Capacity:**

- 5” casters. 250 lbs. capacity each.
- Total cart 750 lbs. capacity.

**4-Shelf “Enclosed Standard” Units** with 4 Swivel Casters.

D x W x H (inches)	WT. (lbs.)	CHROME PLUS Part #	DURO SEAL Part #
18 x 36 x 69	106	MEB836CH	MEB836PW
18 x 48 x 69	111	MEB856CH	MEB856PW
18 x 60 x 69	133	MEB866CH	MEB866PW
18 x 72 x 69	142	MEB876CH	MEB876PW
24 x 36 x 69	112	ME436CH	ME436PW
24 x 48 x 69	135	ME456CH	ME456PW
24 x 60 x 69	161	ME466CH	ME466PW
24 x 72 x 69	172	ME476CH	ME476PW

**4-Shelf “Enclosed Braking” Units** with 4 Swivel Casters (2 with brakes).

D x W x H (inches)	WT. (lbs.)	CHROME PLUS Part #	DURO SEAL Part #
18 x 36 x 69	106	MEB836CH	MEB836PW
18 x 48 x 69	111	MEB856CH	MEB856PW
18 x 60 x 69	133	MEB866CH	MEB866PW
18 x 72 x 69	142	MEB876CH	MEB876PW
24 x 36 x 69	112	MEB436CH	MEB436PW
24 x 48 x 69	135	MEB456CH	MEB456PW
24 x 60 x 69	161	MEB466CH	MEB466PW
24 x 72 x 69	172	MEB476CH	MEB476PW

**4-Shelf “Enclosed Standard Complete” Units** with 4 Swivel Casters, 1 solid bottom shelf cover and 4 full-length, 3-position label holders.

D x W x H (inches)	WT. (lbs.)	CHROME PLUS Part #	DURO SEAL Part #
18 x 36 x 69	111	MEB836CH-CL	MEB836PW-CL
18 x 48 x 69	116	MEB856CH-CL	MEB856PW-CL
18 x 60 x 69	138	MEB866CH-CL	MEB866PW-CL
18 x 72 x 69	147	MEB876CH-CL	MEB876PW-CL
24 x 36 x 69	117	ME436CH-CL	ME436PW-CL
24 x 48 x 69	140	ME456CH-CL	ME456PW-CL
24 x 60 x 69	166	ME466CH-CL	ME466PW-CL
24 x 72 x 69	177	ME476CH-CL	ME476PW-CL

## LQ Wire Shelving and Carts

### 5-Shelf "Enclosed Standard" Units

with 4 Swivel Casters.

D x W x H	WT.	CHROME PLUS	DURO SEAL
(inches)	(lbs.)	Part #	Part #
18 x 36 x 80	110	ME835CH	ME835PW
18 x 48 x 80	132	ME855CH	ME855PW
18 x 60 x 80	160	ME865CH	ME865PW
18 x 72 x 80	173	ME875CH	ME875PW
24 x 36 x 80	136	ME435CH	ME435PW
24 x 48 x 80	163	ME455CH	ME455PW
24 x 60 x 80	195	ME465CH	ME465PW
24 x 72 x 80	212	ME475CH	ME475PW

### 5-Shelf "Enclosed Braking" Units

with 4 Swivel Casters (2 with brakes).

D x W x H	WT.	CHROME PLUS	DURO SEAL
(inches)	(lbs.)	Part #	Part #
18 x 36 x 80	110	MEB835CH	MEB835PW
18 x 48 x 80	132	MEB855CH	MEB855PW
18 x 60 x 80	160	MEB865CH	MEB865PW
18 x 72 x 80	173	MEB875CH	MEB875PW
24 x 36 x 80	136	MEB435CH	MEB435PW
24 x 48 x 80	163	MEB455CH	MEB455PW
24 x 60 x 80	195	MEB465CH	MEB465PW
24 x 72 x 80	212	MEB475CH	MEB475PW

### 5-Shelf "Enclosed Standard Complete" Units

with 4 Swivel Casters, 1 solid bottom shelf cover and 5 full-length, 3-position label holders.

D x W x H	WT.	CHROME PLUS	DURO SEAL
(inches)	(lbs.)	Part #	Part #
18 x 36 x 80	115	ME835CH-CL	ME835PW-CL
18 x 48 x 80	137	ME855CH-CL	ME855PW-CL
18 x 60 x 80	165	ME865CH-CL	ME865PW-CL
18 x 72 x 80	178	ME875CH-CL	ME875PW-CL
24 x 36 x 80	141	ME435CH-CL	ME435PW-CL
24 x 48 x 80	168	ME455CH-CL	ME455PW-CL
24 x 60 x 80	200	ME465CH-CL	ME465PW-CL
24 x 72 x 80	217	ME475CH-CL	ME475PW-CL

#### Standard Unit Components:

- 4 each 74"H posts.
- 5 wire shelves with split sleeves.
- 3" x 3" mesh enclosure panels on side and back.
- 5" swivel non-marking polyurethane casters.
- Donut bumpers.

#### "Complete" Units Accessories (-CL):

- 5 full-length 3-position label holders.
- Bottom shelf cover, solid, flat, poly.

#### Weight Capacity:

- 5" casters. 250 lbs. capacity each.
- Total cart 750 lbs. capacity.

### 5-Shelf Enclosed Mobile Wire Shelving 80"H

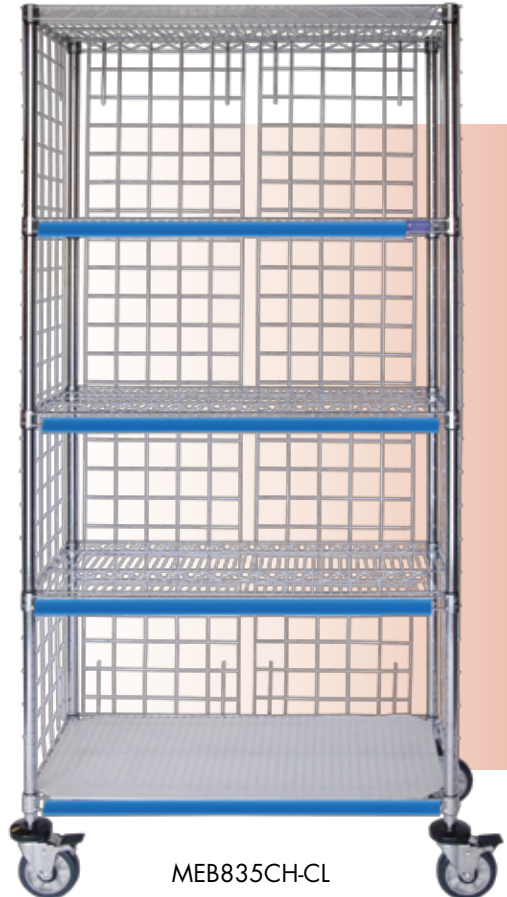

MEB835CH-CL

### 5-Shelf "Enclosed Braking Complete" Units

with 4 Swivel Casters (2 with brakes), 1 solid bottom shelf cover and 5 full-length, 3-position label holders.

D x W x H	WT.	CHROME PLUS	DURO SEAL
(inches)	(lbs.)	Part #	Part #
18 x 36 x 80	115	MEB835CH-CL	MEB835PW-CL
18 x 48 x 80	137	MEB855CH-CL	MEB855PW-CL
18 x 60 x 80	165	MEB865CH-CL	MEB865PW-CL
18 x 72 x 80	178	MEB875CH-CL	MEB875PW-CL
24 x 36 x 80	141	MEB435CH-CL	MEB435PW-CL
24 x 48 x 80	168	MEB455CH-CL	MEB455PW-CL
24 x 60 x 80	200	MEB465CH-CL	MEB465PW-CL
24 x 72 x 80	217	MEB475CH-CL	MEB475PW-CL



## LQ Wire Shelving and Carts

### Open Dolly Base Carts, 4-Tier



MDS456CH-6

#### Standard Units Include:

- 4 each 63"H posts.
- 4 wire shelves with split sleeves.
- Heavy-duty all-welded dolly fabricated with C-channel welded to steel plate frame.
- Non-marking wrap-around bumper.  
Dolly is available open, with premium epoxy-coated solid insert or with stainless steel solid insert. Inserts adhere to infection control standards and function as solid bottom shelves.

#### Other Standard Sizes Available on Request:

- Depths: 18" and 21"
- Widths: 42" and 54"
- Posts: 74"

#### Open Cart with Open Dolly, 4 Wire Shelves.

D x W	WT.	5" PLATE CASTER	6" PLATE CASTER
(inches)	(lbs.)	Model #, Ht (in)	Model #, Ht (in)
24 x 36	122	MD436CH 70	MD436CH-6 71
24 x 48	149	MD456CH 70	MD456CH-6 71
24 x 60	182	MD466CH 70	MD466CH-6 71
24 x 72	217	MD476CH 70	MD476CH-6 71

\* Add the suffix "-CL" to model number for solid bottom shelf cover and 3-position label holder  
\*Height is overall

#### Open Cart with Premium Epoxy-Coated Solid Insert Dolly, 4 Wire Shelves.

D x W	WT.	5" PLATE CASTER	6" PLATE CASTER
(inches)	(lbs.)	Model #, Ht (in)	Model #, Ht (in)
24 x 36	124	MDT436CH 70	MDT436CH-6 71
24 x 48	146	MDT456CH 70	MDT456CH-6 71
24 x 60	170	MDT466CH 70	MDT466CH-6 71
24 x 72	197	MDT476CH 70	MDT476CH-6 71

\*\* Add the suffix "-CL" to model number for 3-position label holders for wire shelves only (solid bottom cover not required)

#### Open Cart with Stainless Steel Solid Insert Dolly 4 Wire Shelves.

D x W	WT.	5" PLATE CASTER	6" PLATE CASTER
(inches)	(lbs.)	Model #, Ht (in)	Model #, Ht (in)
24 x 36	124	MDS436CH 70	MDS436CH-6 71
24 x 48	146	MDS456CH 70	MDS456CH-6 71
24 x 60	170	MDS466CH 70	MDS466CH-6 71
24 x 72	197	MDS476CH 70	MDS476CH-6 71

\* Add the suffix "-CL" to the model number for 3-position label holders for wire shelves only (solid bottom cover not required)

#### 5" Caster Models:

- 4 each 5" plate-style swivel non-marking polyurethane casters, two with brakes.
- Weight capacity is 750 lbs. (each caster 250 lbs.)

#### 6" Caster "Heavy-Duty" Models:

- 4 each 6" premium ergonomic elastomere non-marking casters. All swivel, two with brakes.
- Rigid and directional -lock also available.  
Add suffix "BFP" for 1 swivel, 2 swivel w/ brake, and 1 directional locking.  
Add suffix "R" for 2 fixed, 2 swivel.  
Add suffix "FP" for 1 directional locking.
- 1200 lb weight capacity (each caster 400 lbs.)
- Recommended for "heavy-duty" transport applications.

## LQ Wire Shelving and Carts

### Open Dolly Base Carts, 5-Tier

#### Open Cart with Dolly, 5 Wire Shelves.

D x W x H	WT.	5" PLATE CASTER		6" PLATE CASTER	
(inches)	(lbs.)	Model #, Ht (in)	Model #, Ht (in)	Model #, Ht (in)	Model #, Ht (in)
24 x 36 x 83	138	MD435CH 81	MD435CH-6 82	MD435CH-6 82	
24 x 48 x 83	168	MD455CH 81	MD455CH-6 82	MD455CH-6 82	
24 x 60 x 83	206	MD465CH 81	MD465CH-6 82	MD465CH-6 82	
24 x 72 x 83	246	MD475CH 81	MD475CH-6 82	MD475CH-6 82	

\* Add the suffix "CL" to model number for solid bottom shelf cover and 3-position label holder  
 \* Height is overall

#### Open Cart with Premium Epoxy-Coated Solid Insert Dolly, 5 Wire Shelves.

D x W x H	WT.	5" PLATE CASTER		6" PLATE CASTER	
(inches)	(lbs.)	Model #, Ht (in)	Model #, Ht (in)	Model #, Ht (in)	Model #, Ht (in)
24 x 36 x 83	140	MDT435CH 81	MDT435CH-6 82	MDT435CH-6 82	
24 x 48 x 83	171	MDT455CH 81	MDT455CH-6 82	MDT455CH-6 82	
24 x 60 x 83	194	MDT465CH 81	MDT465CH-6 82	MDT465CH-6 82	
24 x 72 x 83	226	MDT475CH 81	MDT475CH-6 82	MDT475CH-6 82	

\*\* Add the suffix "CL" to model number for 3-position label holders for wire shelves only (solid bottom cover not required)

#### Open Cart with Stainless Steel Solid Insert Dolly 5 Wire Shelves.

D x W x H	WT.	5" PLATE CASTER		6" PLATE CASTER	
(inches)	(lbs.)	Model #, Ht (in)	Model #, Ht (in)	Model #, Ht (in)	Model #, Ht (in)
24 x 36 x 83	140	MDS435CH 81	MDS435CH-6 82	MDS435CH-6 82	
24 x 48 x 83	171	MDS455CH 81	MDS455CH-6 82	MDS455CH-6 82	
24 x 60 x 83	194	MDS465CH 81	MDS465CH-6 82	MDS465CH-6 82	
24 x 72 x 83	226	MDS475CH 81	MDS475CH-6 82	MDS475CH-6 82	

\* Add the suffix "CL" to the model number for 3-position label holders for wire shelves only (solid bottom cover not required)



MD455CH-6

#### Standard Units Include:

- 4 each 74"H posts.
  - 5 wire shelves with split sleeves.
  - Heavy-duty all-welded dolly fabricated with C-channel welded to steel plate frame.
  - Non-marking wrap-around bumper.
- Dolly is available open, with premium epoxy-coated solid insert or with stainless steel solid insert. Inserts adhere to infection control standards and function as solid bottom shelves.

#### Other Standard Sizes Available on Request:

- Depths: 18" and 21"
- Widths: 42" and 54"
- Posts: 63"

#### 5" Caster Models:

- 4 x 5" plate-style swivel non-marking polyurethane casters, two with brakes.
- Weight capacity is 750 lbs. (each caster 250 lbs.)

#### 6" Caster "Heavy-Duty" Models:

- 4 each 6" premium ergonomic elastomere non-marking casters. All swivel, two with brakes.
- Rigid and directional-lock also available.  
 Add suffix "BFP" for 1 swivel, 2 swivel w/ brake, and 1 directional locking.  
 Add suffix "R" for 2 fixed, 2 swivel.  
 Add suffix "FP" for 1 directional locking.
- 1200 lb weight capacity (each caster 400 lbs.)
- Recommended for "heavy-duty" transport applications.

## LQ Wire Shelving and Carts

### Enclosed Dolly Base Carts, 4-Tier

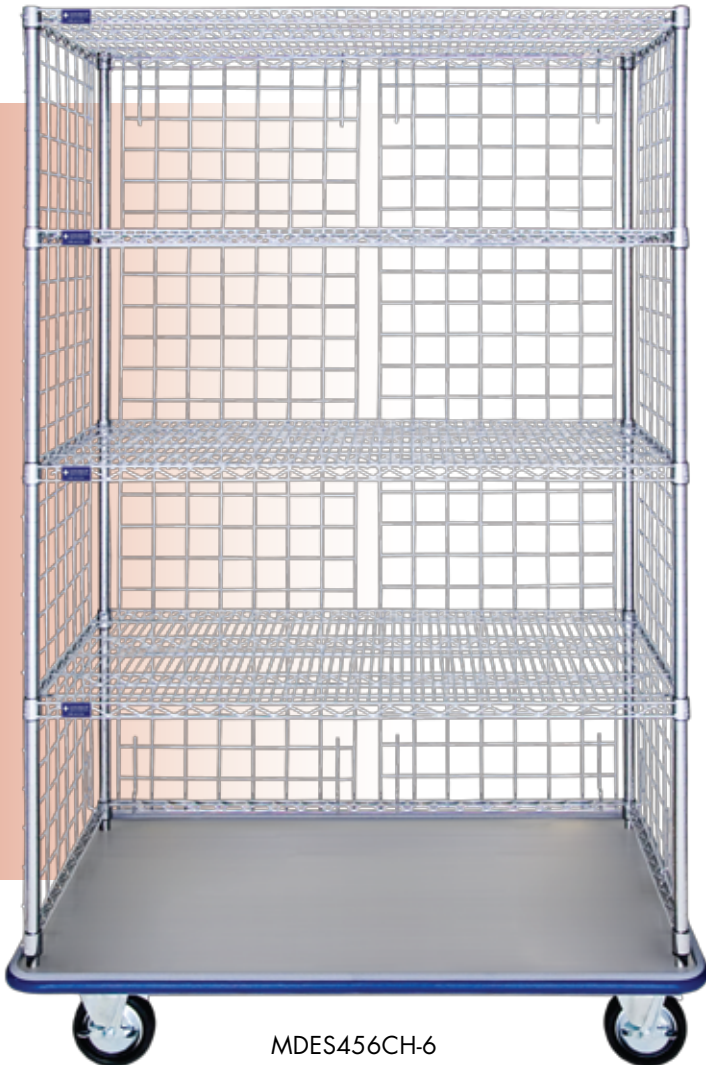

MDES456CH-6

#### Standard Units Include:

- 4 each 63”H posts.
- 4 wire shelves with split sleeves.
- Enclosure panels of 3” x 3” wire mesh.
- Heavy-duty all-welded dolly fabricated with C-channel welded to steel plate frame.
- Non-marking wrap-around bumper.

Dolly is available open, with premium epoxy-coated solid insert or with stainless steel solid insert. Inserts adhere to infection control standards and function as solid bottom shelves.

#### Enclosed Cart with Open Dolly, 4 Wire Shelves.

D x W	WT.	5” PLATE CASTER	6” PLATE CASTER
(inches)	(lbs.)	Model #, Ht (in)	Model #, Ht (in)
24 x 36	184	MDE436CH 70	MDE436CH-6 71
24 x 48	224	MDE456CH 70	MDE456CH-6 71
24 x 60	273	MDE466CH 70	MDE466CH-6 71
24 x 72	323	MDE476CH 70	MDE476CH-6 71

\*Add the suffix “-CL” to model number for solid bottom shelf cover and 3-position label holder  
\*Height is overall

#### Enclosed Cart with Premium Epoxy-Coated Solid Insert Dolly, 4 Wire Shelves.

D x W	WT.	5” PLATE CASTER	6” PLATE CASTER
(inches)	(lbs.)	Model #, Ht (in)	Model #, Ht (in)
24 x 36	186	MDET436CH 70	MDET436CH-6 71
24 x 48	221	MDET456CH 70	MDET456CH-6 71
24 x 60	261	MDET466CH 70	MDET466CH-6 71
24 x 72	303	MDET476CH 70	MDET476CH-6 71

\*\*Add the suffix “-CL” to the model number for 3-position label holders for wire shelves only (solid bottom cover not required)

#### Enclosed Cart with Stainless Steel Solid Insert Dolly, 4 Wire Shelves.

D x W x H	WT.	5” PLATE CASTER	6” PLATE CASTER
(inches)	(lbs.)	Model #, Ht (in)	Model #, Ht (in)
24 x 36	186	MDES436CH 70	MDES436CH-6 71
24 x 48	221	MDES456CH 70	MDES456CH-6 71
24 x 60	261	MDES466CH 70	MDES466CH-6 71
24 x 72	303	MDES476CH 70	MDES476CH-6 71

\*\* Add the suffix “-CL” to the model number for 3-position label holders for wire shelves only (solid bottom cover not required)

#### 5” Caster Models:

- 4 each 5” plate-style swivel non-marking polyurethane casters, two with brakes.
- Weight capacity is 750 lbs. (each caster 250 lbs.)

#### 6” Caster “Heavy-Duty” Models:

- 4 each 6” premium ergonomic elastomere non-marking casters. All swivel, two with brakes.
- Rigid and directional-lock also available.
- Add suffix “BFP” for 1 swivel, 2 swivel w/ brake, and 1 directional locking.
- Add suffix “R” for 2 fixed, 2 swivel.
- Add suffix “FP” for 1 directional locking.
- 1200 lb weight capacity (each caster 400 lbs.)
- Recommended for “heavy-duty” transport applications.



## LQ Wire Shelving and Carts

### Enclosed Dolly Base Carts, 5-Tier

#### Enclosed Cart with Open Dolly 5 Wire Shelf.

D x W	WT.	5" PLATE CASTER		6" PLATE CASTER	
(inches)	(lbs.)	Model #, Ht (in)	Model #, Ht (in)	Model #, Ht (in)	Model #, Ht (in)
24 x 36	200	MDE435CH 81	MDE435CH-6 82	MDE435CH-6 82	MDE435CH-6 82
24 x 48	243	MDE455CH 81	MDE455CH-6 82	MDE455CH-6 82	MDE455CH-6 82
24 x 60	297	MDE465CH 81	MDE465CH-6 82	MDE465CH-6 82	MDE465CH-6 82
24 x 72	352	MDE475CH 81	MDE475CH-6 82	MDE475CH-6 82	MDE475CH-6 82

\*Add the suffix "-CL" to model number for solid bottom shelf cover and 3-position label holder

\*Height is overall

#### Enclosed Cart with Premium Epoxy-Coated Solid Insert, 5 Wire Shelf.

D x W	WT.	5" PLATE CASTER		6" PLATE CASTER	
(inches)	(lbs.)	Model #, Ht (in)	Model #, Ht (in)	Model #, Ht (in)	Model #, Ht (in)
24 x 36	202	MDET435CH 81	MDET435CH-6 82	MDET435CH-6 82	MDET435CH-6 82
24 x 48	246	MDET455CH 81	MDET455CH-6 82	MDET455CH-6 82	MDET455CH-6 82
24 x 60	285	MDET465CH 81	MDET465CH-6 82	MDET465CH-6 82	MDET465CH-6 82
24 x 72	332	MDET475CH 81	MDET475CH-6 82	MDET475CH-6 82	MDET475CH-6 82

\*\* Add the suffix "-CL" to model number for 3-position label holders for wire shelves only (solid bottom cover not required)

#### Enclosed Cart with Solid Stainless insert, 5 Wire Shelf.

D x W	WT.	5" PLATE CASTER		6" PLATE CASTER	
(inches)	(lbs.)	Model #, Ht (in)	Model #, Ht (in)	Model #, Ht (in)	Model #, Ht (in)
24 x 36	202	MDES435CH 81	MDES435CH-6 82	MDES435CH-6 82	MDES435CH-6 82
24 x 48	246	MDES455CH 81	MDES455CH-6 82	MDES455CH-6 82	MDES455CH-6 82
24 x 60	285	MDES465CH 81	MDES465CH-6 82	MDES465CH-6 82	MDES465CH-6 82
24 x 72	332	MDES475CH 81	MDES475CH-6 82	MDES475CH-6 82	MDES475CH-6 82

\* Add the suffix "-CL" to model number for 3-position label holders for wire shelves only (solid bottom cover not required)

#### Standard Units Include:

- 4 each 74"H posts.
- 5 wire shelves with split sleeves.
- Enclosure panels of 3" x 3" wire mesh.
- Heavy-duty all-welded dolly fabricated with C-channel welded to steel plate frame.
- Non-marking wrap-around bumper.

Dolly is available open, with premium epoxy-coated solid insert or with stainless steel solid insert. Inserts adhere to infection control standards and function as solid bottom shelves.

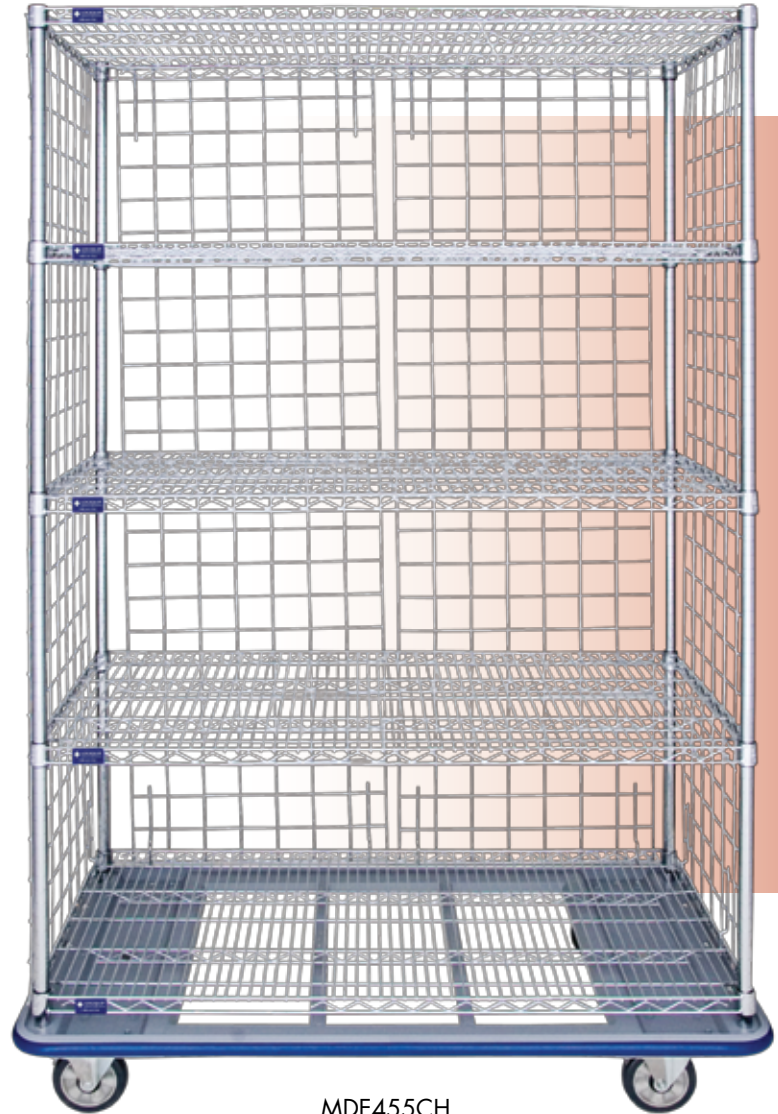

MDE455CH

#### 5" Caster Models:

- 4 each 5" plate-style swivel non-marking polyurethane casters, two with brakes.
- Weight capacity is 750 lbs. (each caster 250 lbs.)

#### 6" Caster "Heavy-Duty" Models:

- 4 each 6" premium ergonomic elastomere non-marking casters. All swivel, two with brakes.
- Rigid and directional-lock also available.

Add suffix "BFP" for 1 swivel, 2 swivel w/ brake, and 1 directional locking.

Add suffix "R" for 2 fixed, 2 swivel.

Add suffix "FP" for 1 directional locking.

- 1200 lb weight capacity (each caster 400 lbs.)
- Recommended for "heavy-duty" transport applications.

# LQ Wire Shelving and Carts

## LQ Wire Shelves

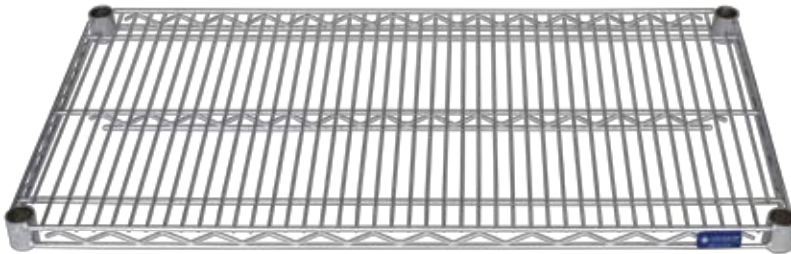

1836CH

### Shelves

- Shelves are adjustable on 1" increments and come in a wide selection of sizes to suit every application.
- Chrome Plus Finish: Heavy nickel plating with hard chromium finish excellent for dry storage hospital applications.
- Duro Seal: Clear, heavy-coat finish over chrome, that is perfect for sterile packs, drapes, wrapped instrument sets and high-humidity applications. 10-year warranty against rust.

### Weight Capacities

- Up to 48": 800 lbs. per shelf.
- Over 48": 600 lbs. per shelf.

### Split Sleeve Adapters:

4 included with each shelf

SPLIT ADAPTER	MODEL #
4 Per Bag	PBAG

### Posts

Posts are constructed of one-inch round (16 GA) tubing. All posts are numbered and adjustable on one-inch increments. Posts can be ordered without leveling feet for stem caster applications.

*Special post lengths will require the next longer post size and a cut charge of \$3.00 ea.*

- Simple Assembly: Each shelf comes with 4 corner split sleeve adapters which snap into the grooves of the post. The shelf slips over the top surface securing shelf and adapter to post.

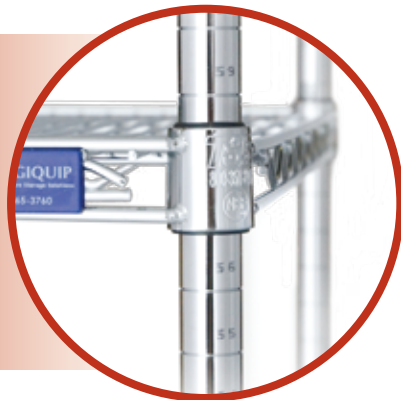

### LQ Posts

HT.	WT.	CHROME PLUS	DURO SEAL
(inches)	(lbs.)	Model #	Model #
14	1	P14CH	P14PW
27	1.5	P27CH	P27PW
34	2	P34CH	P34PW
54	3	P54CH	P54PW
63	3.5	P63CH	P63PW
74	4	P74CH	P74PW
86	5	P86CH	P86PW

## LQS Wire Shelves

D x W	WT.	CHROME PLUS	DURO SEAL
(inches)	(lbs.)	Model #	Model #
14 x 24	6	1424CH	1424PW
14 x 30	7	1430CH	1430PW
14 x 36	8	1436CH	1436PW
14 x 42	9.5	1442CH	1442PW
14 x 48	10.5	1448CH	1448PW
14 x 60	14	1460CH	1460PW
14 x 72	17	1472CH	1472PW
18 x 24	7	1824CH	1824PW
18 x 30	8	1830CH	1830PW
18 x 36	9.5	1836CH	1836PW
18 x 42	11	1842CH	1842PW
18 x 48	12	1848CH	1848PW
18 x 54	14.5	1854CH	1854PW
18 x 60	17	1860CH	1860PW
18 x 72	20	1872CH	1872PW
21 x 24	8	2124CH	2124PW
21 x 30	9	2130CH	2130PW
21 x 36	11	2136CH	2136PW
21 x 42	12	2142CH	2142PW
21 x 48	14	2148CH	2148PW
21 x 54	16	2154CH	2154PW
21 x 60	18	2160CH	2160PW
21 x 72	23	2172CH	2172PW
24 x 24	9	2424CH	2424PW
24 x 30	11	2430CH	2430PW
24 x 36	13	2436CH	2436PW
24 x 42	15	2442CH	2442PW
24 x 48	16	2448CH	2448PW
24 x 54	19	2454CH	2454PW
24 x 60	21	2460CH	2460PW
24 x 72	26	2472CH	2472PW



909-AP

BPC



PLUG-01

### Post Level and Post Cap

- One included with every post.
- Metal foot plug insert for round post Model #PLUG-01.
- Adjustable foot bolt for round post Model #909-AP.
- Black plastic post cap Model #BPC.

# LQ Wire Shelving and Carts

## Casters + Dolly Bases

**Stem Casters:** For use with posts.

Non-marking polyurethane

SIZE	WT.	CAPACITY	SWIVEL	RIGID	SWIVEL W/ BRAKE
(inches)	(lbs.)	(lbs.)	Model #	Model #	Model #
5 x 1.25	2	250	5C	5CR	5CB



5C



5CB



C5



C5B

**Plate Casters:** For use with dollies.

5" Casters: Non-marking polyurethane.

SIZE	WT.	CAPACITY	SWIVEL	RIGID	SWIVEL W/ BRAKE
(inches)	(lbs.)	(lbs.)	Model #	Model #	Model #
5 x 1.25	2	250	C5	C5R	C5B



31-76RXSR



31-76BXS

6" Casters: Premium ergonomic elastomere non-marking casters. For heavy-duty transport.

SIZE	WT.	CAPACITY	SWIVEL	RIGID	SWIVEL W/ BRAKE	4-POSITION DIRECTION LOCK
(inches)	(lbs.)	(lbs.)	Model #	Model #	Model #	Model #
6 x 2	4	800	31-76XSR	31-76RXSR	31-76BXS	31-76FPXSR

Many other casters available to suit specialty applications



RDB325

**Donut Bumpers:** For use with stem casters.

Non-marking polyurethane

SIZE	WT.	Model #
(inches)	(lbs.)	Model #
3.5	.25	RDB325

THP9448NSCH  
Closed Dolly with Stainless Insert

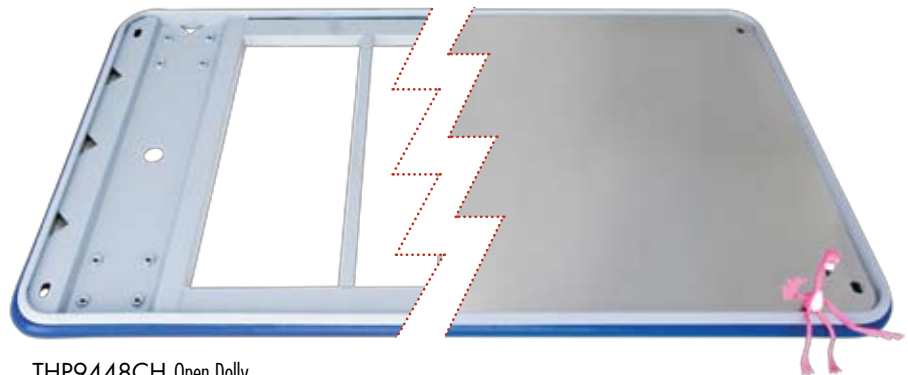

THP9448CH Open Dolly

### Dolly Bases

DIMENSIONS	WT.	OPEN	SOLID EPOXY INSERT	SOLID STAINLESS INSERT
(inches)	(lbs.)	Model #	Model #	Model #
18 x 36	30	THP9836CH	THP9836NTCH	THP9836NSCH
18 x 48	40	THP9848CH	THP9848NTCH	THP9848NSCH
18 x 60	50	THP9860CH	THP9860NTCH	THP9860NSCH
18 x 72	60	THP9872CH	THP9872NTCH	THP9872NSCH
24 x 36	40	THP9436CH	THP9436NTCH	THP9436NSCH
24 x 48	53	THP9448CH	THP9448NTCH	THP9448NSCH
24 x 60	67	THP9460CH	THP9460NTCH	THP9460NSCH
24 x 72	80	THP9472CH	THP9472NTCH	THP9472NSCH

### Dolly Bases

Heavy-duty all-welded dolly fabricated with integral C-channel welded to steel plate frame. Non-marking wrap-around bumper.

Dolly is available in three styles: Open, premium epoxy-coated solid insert or stainless steel solid insert. Inserts adhere to infection control standards and function as solid bottom shelves which eliminates the additional wire shelf requirement.

### Other Standard Sizes Available on Request:

- Depths: 21"
- Widths: 42" and 54"



# LQ Wire Shelving and Carts

## Enclosure Panels + Ledges

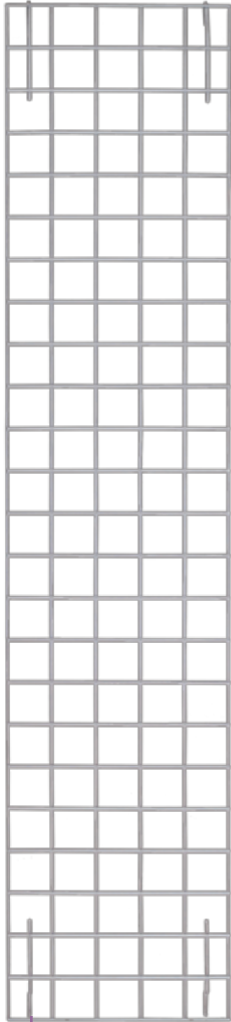

BRD1872CH End Panel

### Back Enclosure Panels: 3" x 3" chrome wire mesh.

POST	SHELF	WT.	CHROME
Height	Length	(lbs.)	Model #
63"	30"	16	BRD3060CH
63"	36"	16.5	BRD3660CH
63"	42"	20.5	BRD4260CH
63"	48"	24	BRD4860CH
63"	54"	27	BRD5460CH
63"	60"	30	BRD6060CH
63"	72"	35	BRD7260CH
74"	30"	19.5	BRD3072CH
74"	36"	20	BRD3672CH
74"	42"	24.5	BRD4272CH
74"	48"	28	BRD4872CH
74"	54"	32	BRD5472CH
74"	60"	35	BRD6072CH
74"	72"	41	BRD7272CH

### Side Enclosure Panels: 3" x 3" chrome wire mesh.

POST	SHELF	WT.	CHROME
Height	Depth	(lbs.)	Model #
63"	18"	7.5	ERD1860CH
63"	21"	9	ERD2160CH
63"	24"	9.5	ERD2460CH
74"	18"	10	ERD1872CH
74"	21"	12	ERD2172CH
74"	24"	13.5	ERD2472CH

### 1" Height Side and Back Ledges: Nickel chrome plated wire.

SIZE	WT.	CHROME
(inches)	(lbs)	Model #
14	0.5	L141CH
18	0.5	L181CH
21	1	L211CH
24	1	L241CH
30	1	L301CH
36	1.5	L361CH
42	1.5	L421CH
48	2	L481CH
54	2	L541CH
60	2.5	L601CH
72	3	L721CH



18"D Side Ledge 4"H



36"W Back Ledge 4"H

### 4" Height Side and Back Ledges: Nickel chrome plated wire.

SIZE	WT.	CHROME
(inches)	(lbs.)	Model #
14	1	L144CH
18	1	L184CH
21	2	L214CH
24	2	L244CH
30	2	L304CH
36	2.5	L364CH
42	2.5	L424CH
48	3	L484CH
54	3	L544CH
60	3.5	L604CH
72	4	L724CH

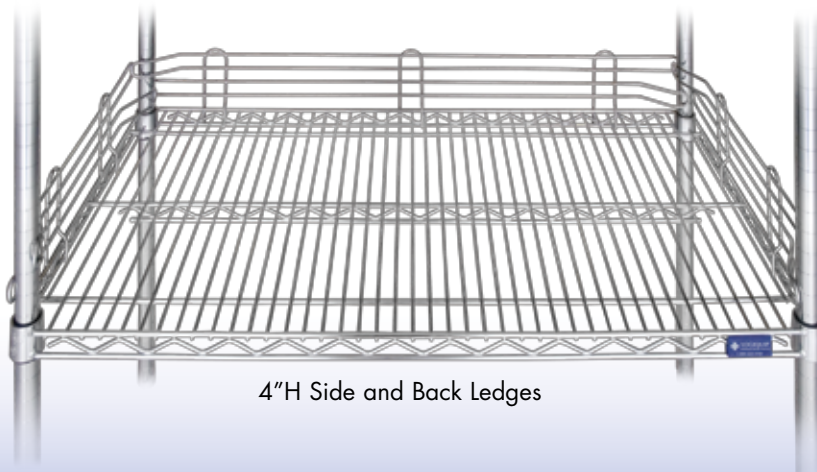

4"H Side and Back Ledges

## LQ Wire Shelving and Carts

### Baskets + Bins

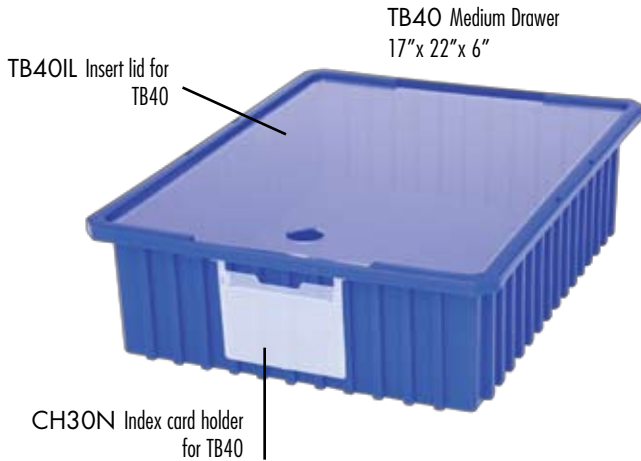

#### Plastic Drawers

- Injection-molded polypropylene.
- Resists most solvents and chemicals.
- Many other sizes of drawers also available.
- Standard Color: Blue. Red also available.

#### Short Divider

- (max 15 per drawer) Pkg of 6  
Model #DV17/D6DS

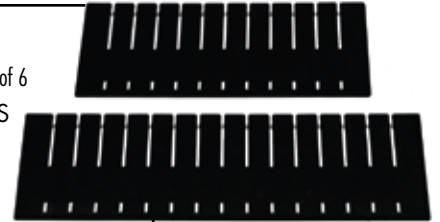

#### Long Divider

- (max 11 per drawer) Pkg of 6  
Model #DV22/D6DL

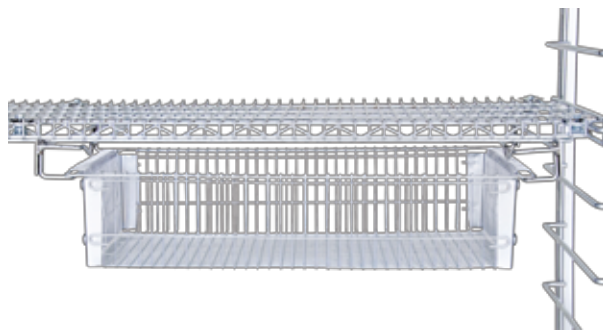

#### Under-Shelf Adjustable Drawer and Basket Holders

- Holder only, medium drawer.
  - Fits Shelf 18" & 24" deep.
  - 2 lbs.
- Model #DS18-24



HB916 Basket

#### Wire Document/Chart Holder

- Attaches to shelf or enclosure panel.
- 12.375" x 2" x 8.625"H.
- 2 lbs.

Model #DH



#### Add-On Basket

D x W x H	WT.	MODEL #
(inches)	(lbs.)	
7 x 15 x 7	2.3	HB715
9 x 16 x 9	4	HB916

#### Wire Baskets

DESCRIPTION	WT.	MODEL #
	(lbs.)	
Medium Basket 16"D x 24"W x 5"H	5	B5-III
Long divider for medium basket	0.5	B5DL-III
Short divider for medium basket	0.5	B5DS-III
Label tag for medium basket 1" x 3"		LH3

Standard Color: Off-white. Nickel-chrome plated wire also available

\* 3"H and 8"H also available - see page 16.

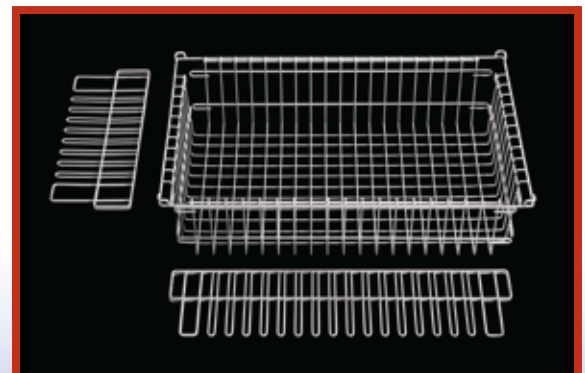

B5-III shown with dividers

## LQ Wire Shelving and Carts

### Handles + 3-Sided Frame + Dunnage Rack

#### Push Handle

- All-welded chrome steel tubing.
- Push/pull handle keeps hands away from product.

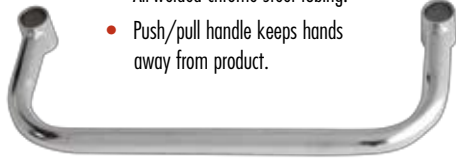

#### Push Handle

SHELF WIDTH (inches)	WT. (lbs.)	CHROME Model #
18	1.5	PH18CH
21	2	PH21CH
24	2.5	PH24CH



#### U-Handle

- Overall height 30".
- Use in place of posts for utility cart purposes.

#### U-Handle

SHELF WIDTH (inches)	WT. (lbs.)	CHROME Model #
18	6	RD18CH
21	7	RD21CH
24	8	RD24CH

#### 3-Sided Frame

- Increase stability & support.
- Nickel-chrome plated wire frame.

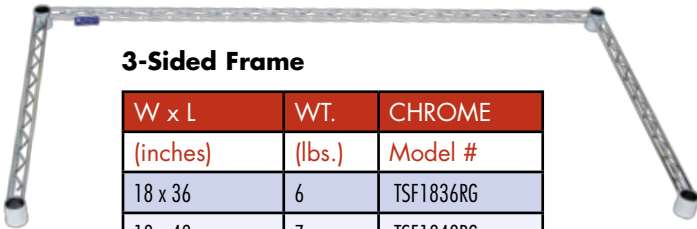

#### 3-Sided Frame

W x L (inches)	WT. (lbs.)	CHROME Model #
18 x 36	6	TSF1836RG
18 x 48	7	TSF1848RG
18 x 60	8	TSF1860RG
24 x 36	7	TSF2436RG
24 x 48	9	TSF2448RG
24 x 60	11	TSF2460RG

#### Ergonomic Upright Handle (NOT PICTURED)

- All-welded chrome steel tubing.
- Save space by turning in on posts.
- Secures with included split adapters.
- Two handles required per application.

#### Ergonomic Upright Handle

LENGTH (inches)	WT. (lbs.)	CHROME Model #
18	1.5	UPH18CH

#### Dunnage Rack

SIZE (inches)	WT. (lbs.)	ALUMINUM Model #
18 x 36 x 10.5	16	AL1836
18 x 48 x 10.5	19	AL1848
24 x 36 x 10.5	18	AL2436
24 x 48 x 10.5	22	AL2448
24 x 60 x 10.5	26	AL2460



AL1848



## LQ Wire Shelving and Carts

### Foot Plates + S-Hooks + Seismic Bracing



#### Add-On S-Hooks

- Use instead of posts.
- 2 hooks required for each shelf connection.
- Use in corners for L-shape configurations.
- Use on the side for back-to-back units.
- Use on the ends for continuous run of shelving.
- Chrome.

Model #PBC200



#### Foot Plate

Allows bolting of shelving unit into floor.

*Anchor not included.*

Model #FP Chrome

Model #SFP Stainless Steel



#### Post Clamp

Ties back to back shelving units together at posts.

Model #CLPCH Chrome



#### Seismic Foot Plates

- Seismic-approved footplates supplied with cotter pin attachment and Hilti anchor bolts.
- Approved by California Office of Statewide Health Planning and Development.

#### Seismic Foot Plates

DESCRIPTION	D x W x H (inches)	WT. (lbs.)	MODEL #
Single Post Foot Plate	2-7/8 x 7 x 4-3/16	2	SIS-PLT1
Double Post Foot Plate	2-7/8 x 11 x 4-3/16	3	SIS-PLT2

#### Seismic End Brace Kits

SHELF DEPTH (inches)	WT. (lbs.)	CHROME Model #
18	3	SIS18EC
21	3	SIS21EC
24	3	SIS24EC

#### Seismic Back Brace Kits

SHELF LENGTH (inches)	WT. (lbs.)	CHROME Model #
36	4	SIS36BC
48	4	SIS48BC
60		SIS60BC

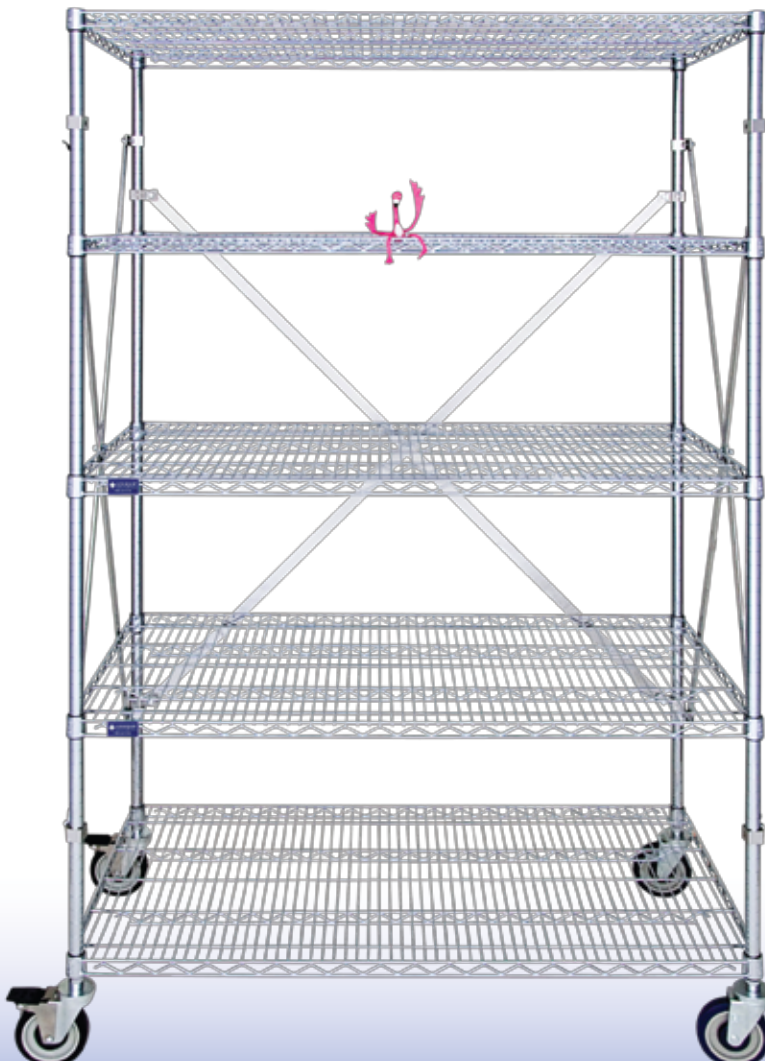

# LQ Wire Shelving and Carts

## Labels Tags + Holders



Label Holder

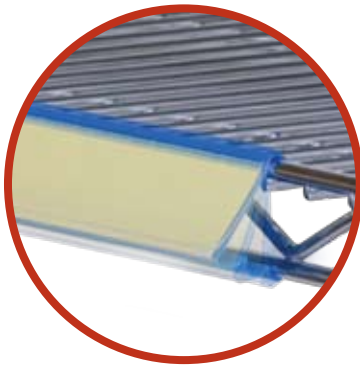

### 3 Position Label Holders

- Clear front pouch.
- Multiple angles in 1 product.

Model #LH30BL

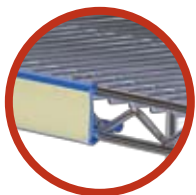

Flat

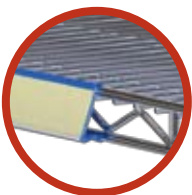

10° Angle

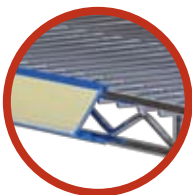

30° Angle



### Label Tags- Standard

- Accommodate 1" x 3" labels.
- Bags of 125.

Model #LH3

### Label Tags- Standard Colors

DESCRIPTION	W x H (inches)	QTY bag of	MODEL #
White Label Tag	1 x 3	125	LH3
Blue Label Tag	1 x 3	125	LH3-BLUE
Yellow Label Tag	1 x 3	125	LH3-YELLOW
Red Label Tag	1 x 3	125	LH3-RED
Green Label Tag	1 x 3	125	LH3-GREEN

### Label Holders

WIDTH (inches)	MODEL #
3	LH03BL
24	LH24BL
30	LH30BL
36	LH36BL
42	LH42BL
48	LH48BL
54	LH54BL
60	LH60BL
72	LH72BL



# LQ Wire Shelving and Carts

## Dividers + Rods & Tabs

### Wire Basket/Shelf Dividers

#### Wire Basket/Shelf Dividers

- Nickel-chrome plated wire.
- Bottom 3-hook design fits all standard shelves and wire IV baskets. 6" and 8" heights.

SHELF SIZE (inches)	WT. (lbs.)	MODEL # 6"H model	MODEL # 8"H model
18 (will also fit 21)	1	CFDIV186	CFDIV188
24	1.4	CFDIV246	CFDIV248

CF-style dividers

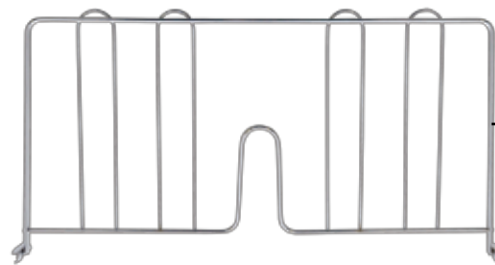
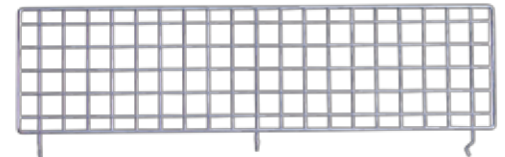
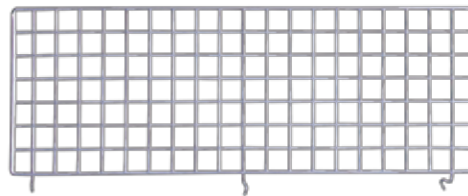
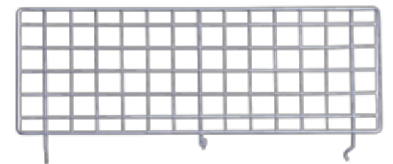
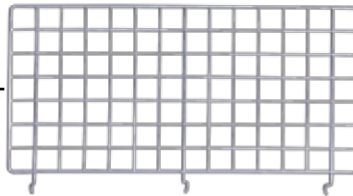

D188CH

### Wire Shelf Dividers

SHELF SIZE (inches)	WT. (lbs.)	MODEL #
14	1	D148CH
18	1	D188CH
21	1.4	D218CH
24	1.4	D248CH

#### Wire Shelf Dividers

- Nickel-chrome plated wire.
- Fits all standard LQS shelves.
- 8"H.
- Locks securely on the shelf.

### Rod and Tab Dividers

POST HEIGHT (inches)	WT. (lbs.)	MODEL #
61	1.5	DVR61RG
72	2	DVR72RG
Additional clips	1	DVCRG (pkg of 12)

#### Rod and Tab Dividers

- Use in multiples to create back/side enclosures or divider panels within a unit.
- Nickel-chrome plated wire.
- Each rod includes 4 clips.



## LQ Wire Shelving and Carts

### Nylon Cart Covers



#### Cart Covers are a Cost Effective Way to Enclose Supplies

- Three available materials: 200 denier, 400 denier or Vicon 10.
- Choose from velcro, tie or zipper closures.
- Clear routing pocket.
- Reinforced corners, double-sewn seams.
- Standard front flap.
- Custom made for any size.

**AntiMicrobial Sure Chek Available upon request.**

#### 200 Denier

- Fire retardant and washable at low temps up to 108F.
- Medium weight nylon fabric with urethane coating on one side for added wear and stain resistance.

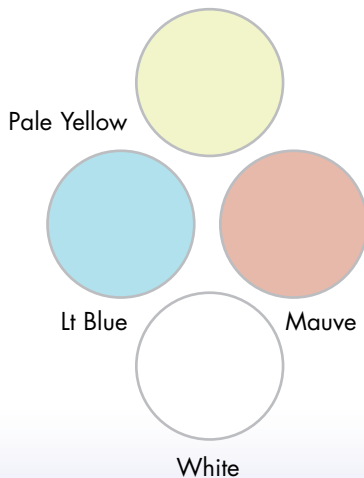

#### 400 Denier

- Most popular. Heavy-weight nylon fabric with urethane coating on one side for added wear, stain resistance and water repellency.

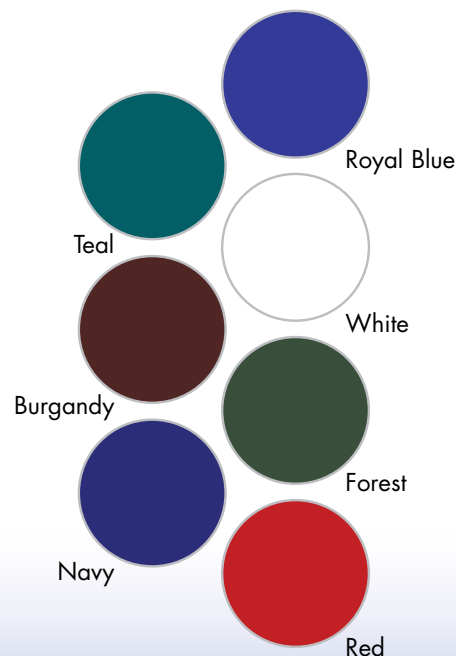

#### Vicon 10

- Heaviest-weight durable nylon fabric with urethane coating on one side for added wear, stain resistance and water repellency.

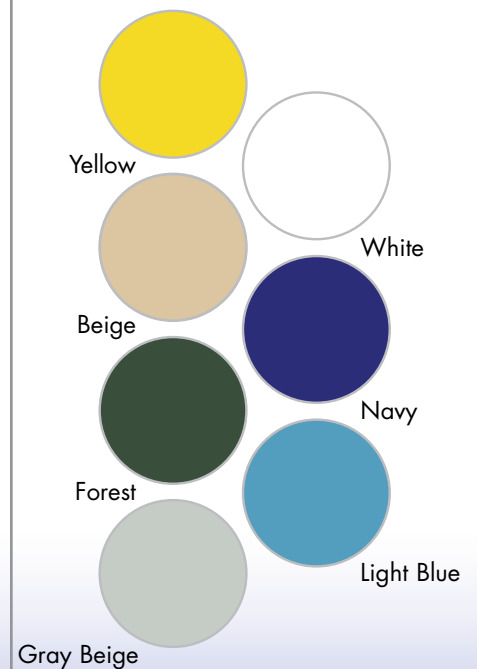

## LQ Wire Shelving and Carts

### Cart Covers

#### Typical Corner Configurations

#### How to Design Your Cart Cover

1. Accurately measure width, length and height (do not allow for clearance, give exact measurements, height to above casters.)
2. Determine corner style. (round end, round front or square- see image below)
3. Determine fabric and color.
4. Determine flap material. (nylon or clear vinyl window)
4. Determine flap closure. (velcro, ties or zipper)
5. Indicate any special options.
6. Make a simple illustration, if needed.

\*\* Use our simple online tool at [covers.logiquip.net](http://covers.logiquip.net)

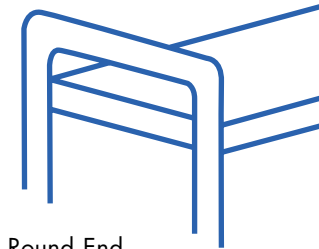

Round End

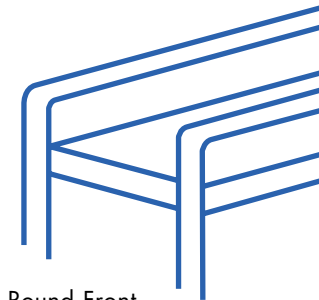

Round Front

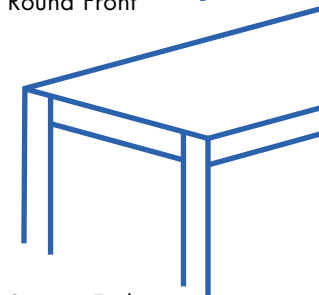

Square End



#### Cart Covers - Disposable Poly

Clear disposable cart/equipment covers on a dispenser roll (50/roll). Clear polyethylene 2 mil thickness.

MODEL #	W x D x H (inches)
16-AR	38 x 26 x 48
16-BR	45 x 27 x 48
16-CR	55 x 27 x 62
16-DR	64 x 27 x 67
16-ER	45 x 27 x 59

# LQ Wire Shelving and Carts

## Floor Track System

### Floor Track System Benefits

- CAD layout options at no cost or obligation.
- We will not recommend a system unless users gain at least 20% more linear footage.
- Units custom built to fit all shelving, existing or new. (Save \$\$\$ using existing)
- Choose from light-duty skates for individual unit tracks or heavy-duty carriages for multiple, back-to-back or mechanical assist units.
- No subfloors construction needed.
- Completely installed, including track install, transfer and assembly of existing units.
- System can easily be added-to and transferred with most parts re-used.

## BEFORE

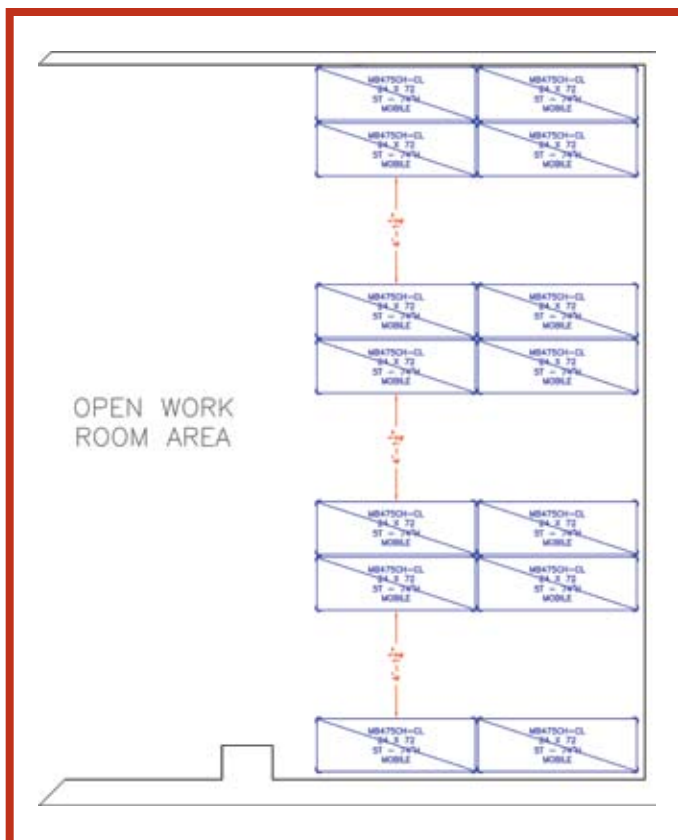

Traditional Static Storage 420 Linear Feet Capacity

## AFTER

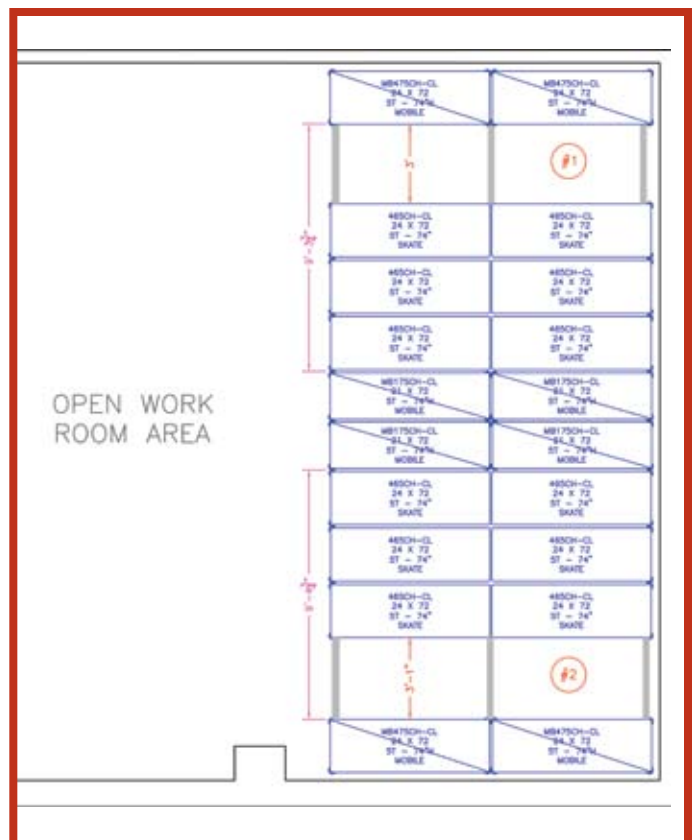

Active Aisle System, 600 Linear Feet,  
Increased Capacity 43% Over Static System



## LQ Wire Shelving and Carts

### Floor Track System

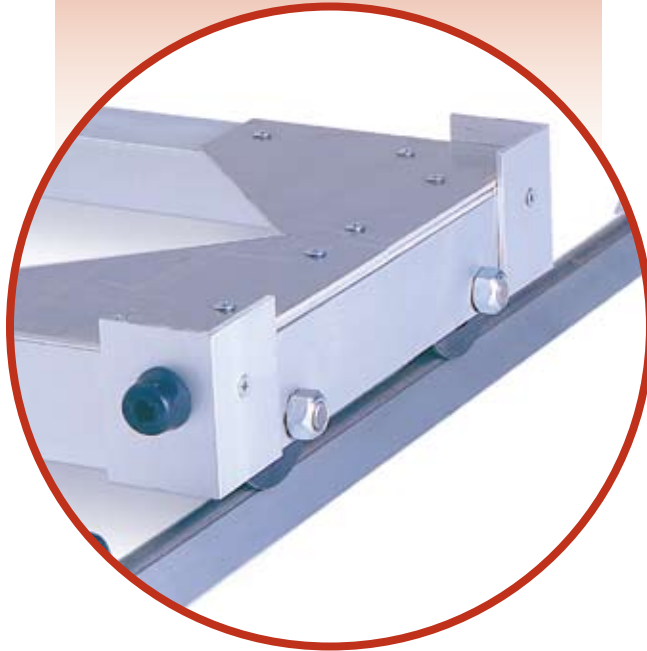

#### CARRIAGE SYSTEM

- Carriages can be up to 12' in length and 4' in depth.
- Ball bearing design allows units up to 2000 lbs. (907kg) to move easily.
- "V" groove floor track is low-profile, cart-friendly and non-trip.
- Carriages: Satin anodized aluminum rails with roller bearing wheel assemblies.
- Track: Aluminum-extruded "V"-design (3/8" at highest peak) with hardened steel inserts. Reduces friction and provides positive carriage retention. Low profile end stops.
- Optional Mechanical Assist: Ergonomically designed easy move aisles, complete with built in aisle control.



Shown with User-Friendly Mechanical Assist

#### SKATE SYSTEM

- Simple and cost-effective solution.
- Easy to configure: Determine length of track needed and provide depth of carts used.
- Aluminum skates with HDP end stops and roller bearing wheels attach to bottom of posts.
- "V" groove floor track is low-profile, cart-friendly and non-trip. (same style as carriages) 3/8"H.



Low-Cost High-Density Storage on Skates

# LQ Wire Shelving and Carts

## Basket/IV Solution Carts



AF011CH

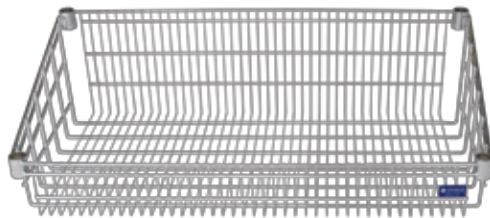

SB2036CH



DV2010CH

### Basket/IV Solution Carts- Highest Density in the Market

- 4 posts 74"H.
- Open front wire baskets & shelves. "SB style".
- Each basket complete with label holders and set # of dividers.
- Bottom wire shelf with solid shelf cover. Top wire shelf.
- 4-5" swivel casters with donut bumpers, two with brakes.

MODEL #	DESCRIPTION	W x D x H (OD)
	Complete IV Cart	(inches)
AF008CH	Complete IV Cart 24" - 2 shelves, 6 baskets, 12 dividers	26 x 18 x 80
AF009CH	Complete IV Cart 36" - 2 shelves, 6 baskets, 18 dividers	38 x 18 x 80
AF010CH	Complete IV Cart 48" - 2 shelves, 6 baskets, 24 dividers	50 x 18 x 80
AF011CH	Complete IV Cart 60" - 2 shelves, 6 baskets, 30 dividers	62 x 18 x 80

MODEL #	DESCRIPTION	W x D x H (OD)
	Wire Basket Only	(inches)
SB2024CH	Individual Wire Basket 24"	24 x 18 x 10
SB2036CH	Individual Wire Basket 36"	36 x 18 x 10
SB2048CH	Individual Wire Basket 48"	48 x 18 x 10
SB2060CH	Individual Wire Basket 60"	60 x 18 x 10
DV2010CH	Wire Basket Divider Standard	16 x 6

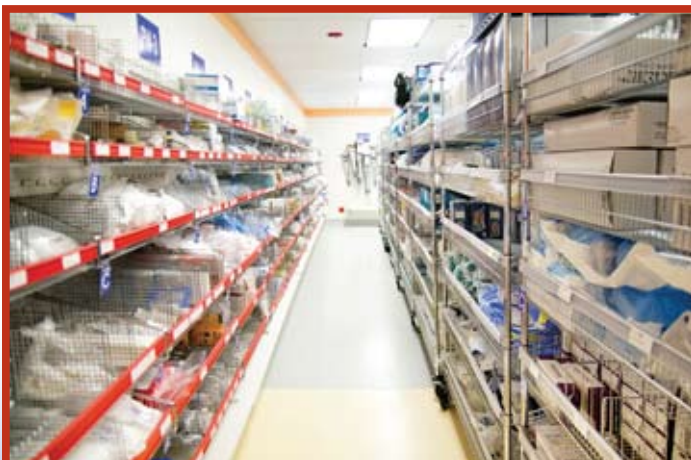

Par Wall® and "AF" carts in Sterile Stores



Bulk IV Storage



# LQ Wire Shelving and Carts

## Basket/IV Solution Carts



"AF" Style Cart with Supplies

### Combo Carts Combine Shelves & Baskets

- 4 posts 74"H..
- Mix of flat wire shelves and baskets with full-length label holders.
- Each basket complete with set # of dividers.
- Bottom wire shelf with solid shelf cover. Top wire shelf.
- 4-5" swivel casters with donut bumpers, two with brakes.



"AF" Style Cart with Gloves



AF511CH



AF411CH



AF020CH

MODEL #	DESCRIPTION	W x D x H (OD)
	<b>Combo Cart</b>	<b>(inches)</b>
AF408CH	Combo Cart 24"- 3 shelves, 4 baskets, 8 basket dividers	26 x 18 x 80
AF508CH	Combo Cart 24"- 2 shelves, 5 baskets, 10 basket dividers	26 x 18 x 80
AF409CH	Combo Cart 36"- 3 shelves, 4 baskets, 12 basket dividers	38 x 18 x 80
AF509CH	Combo Cart 36"- 2 shelves, 5 baskets, 15 basket dividers	38 x 18 x 80
AF410CH	Combo Cart 48"- 3 shelves, 4 baskets, 16 basket dividers	50 x 18 x 80
AF510CH	Combo Cart 48"- 2 shelves, 5 baskets, 20 basket dividers	50 x 18 x 80
AF020CH	Combo Cart 48"- 2 shelves, 5 baskets, 10 basket dividers	50 x 18 x 80
AF411CH	Combo Cart 48"- 3 shelves, 4 baskets, 20 basket dividers	50 x 18 x 80
AF511CH	Combo Cart 48"- 2 shelves, 5 baskets, 25 basket dividers	50 x 18 x 80



## LQ Wire Shelving and Carts

### Suture/Lens/Implant Carts

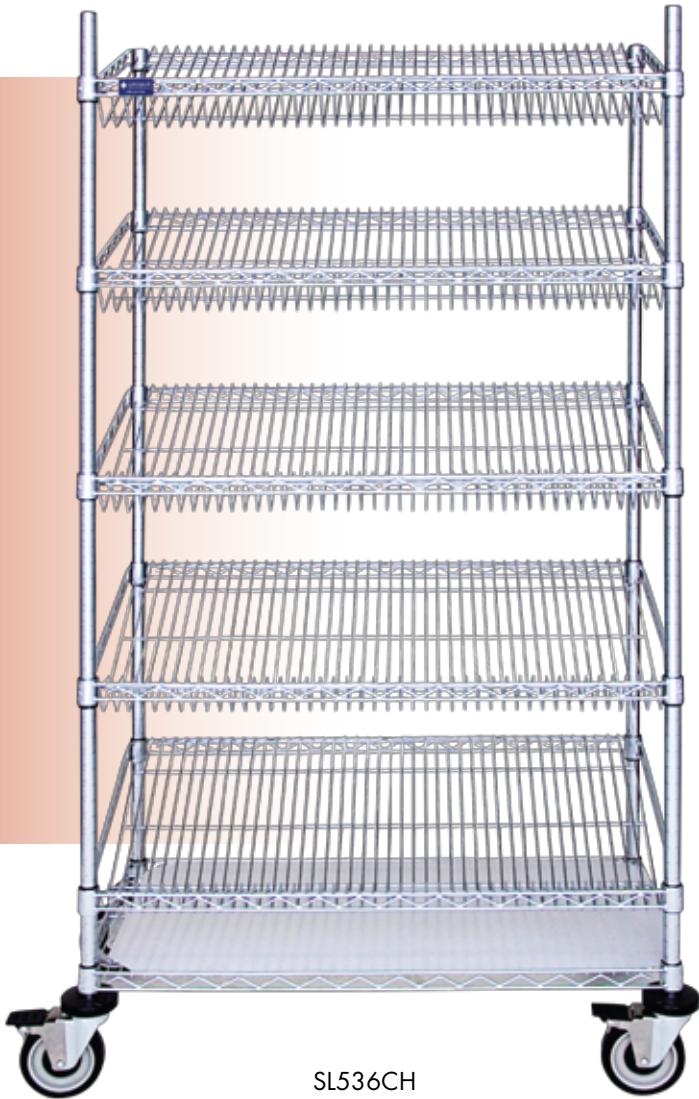

SL536CH

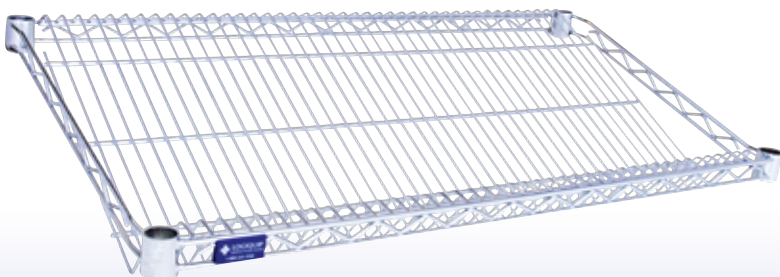

SL36CH

#### Single Sided Suture/Lens/Implant Carts Include

- 4 posts 63"H.
- 4 (or 5- see table) slanted baskets each with label holders.
- Bottom wire shelf with solid shelf cover. (for infection control)
- 4-5" swivel casters with donut bumpers, two with brakes.

MODEL #	DESCRIPTION	D x W x H (OD)
	Single Sided	(inches)
SL424CH	4-Level 24" Single-Sided Suture Cart	18 x 24 x 69
SL436CH	4-Level 36" Single-Sided Suture Cart	18 x 36 x 69
SL448CH	4-Level 48" Single-Sided Suture Cart	18 x 48 x 69
SL524CH	5-Level 24" Single-Sided Suture Cart	18 x 24 x 69
SL536CH	5-Level 36" Single-Sided Suture Cart	18 x 36 x 69
SL548CH	5-Level 48" Single-Sided Suture Cart	18 x 48 x 69
SL24CH	Individual 24" Single Sided Suture Basket	18 x 24 x 10
SL36CH	Individual 36" Single Sided Suture Basket	18 x 36 x 10
SL48CH	Individual 48" Single Sided Suture Basket	18 x 48 x 10



Single Sided Suture Cart in Use

## LQ Wire Shelving and Carts

### Suture/Lens/Implant Carts

#### Double Sided Suture/Lens/Implant Carts Include

- 4 posts 63"H.
- 4 (or 5- see table) slanted baskets each with label holders on both sides.
- Bottom wire shelf with solid shelf cover. (for infection control). Top wire shelf.
- End enclosure panels of 3" x 3" wire mesh
- 4-5" swivel casters with donut bumpers, two with brakes.

MODEL #	DESCRIPTION	D x W x H (OD)
	Double Sided	(inches)
STR424CH	4-Level 24" Double-Sided Suture Cart	24 x 24 x 69
STR436CH	4-Level 36" Double-Sided Suture Cart	24 x 36 x 69
STR448CH	4-Level 48" Double-Sided Suture Cart	24 x 48 x 69
STR524CH	5-Level 24" Double-Sided Suture Cart	24 x 24 x 69
STR536CH	5-Level 36" Double-Sided Suture Cart	24 x 36 x 69
STR548CH	5-Level 48" Double-Sided Suture Cart	24 x 48 x 69
STR24CH	Individual 24" Double Sided Suture Basket	24 x 24 x 69
STR36CH	Individual 36" Double Sided Suture Basket	24 x 36 x 10
STR48CH	Individual 48" Double Sided Suture Basket	24 x 48 x 10

**Suture Cart Capacities:** Sutures packaged in a box of 36 (4-1/2" wide), or boxes of 12 (2-1/4" wide), have a unit capacity of:

#### 24"

MODEL	BOX/36	BOX/12
24" Basket	32	64
424 Cart	68	288
524 Cart	160	360

#### 36"

MODEL	BOX/36	BOX/12
36" Basket	48	112
436 Cart	224	496
536 Cart	280	584

#### 48"

MODEL	BOX/36	BOX/12
48" Basket	64	84
448 Cart	288	608
548 Cart	360	760

**Also Ideal for Storage of Prosthesis and Lenses**



STR524CH

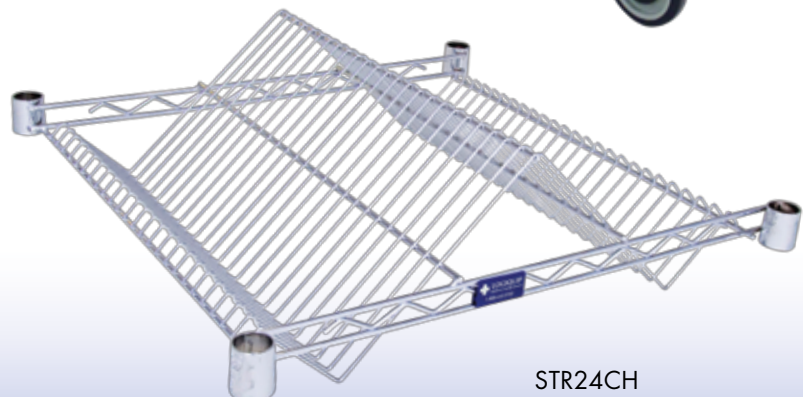

STR24CH



## Wire Shelving and Carts

### Corner Carts - Make the Most of your Space



518367C in use with optional label holders



MB518367C-5CL

#### Complete Units Include:

- 5 posts 74"H.
- 5 wire shelves with 5 corners.
- Full-length label holders on front of all shelves.
- Plastic solid shelf cover on bottom wire shelf.
- 5-5" swivel casters, two with brakes.

MODEL #	DESCRIPTION	W x D x H
	<b>Corner Cart</b>	(inches)
MB518367C-5CL	Corner cart, complete 5-tier, 5-sided	18 x 36 x 79
MB521367C-5CL	Corner cart, complete 5-tier, 5-sided	21 x 36 x 79
MB524427C-5CL	Corner cart, complete 5-tier, 5-sided	24 x 42 x 79

#### Static Corner Units Include:

- 5 posts 74"H.
- 4 or 5 wire shelves with 5 corners.

MODEL #	DESCRIPTION	W x D x H
	<b>Corner Shelving Unit</b>	(inches)
518366C	Corner shelving unit, 4-tier	18 x 36 x 63
518367C	Corner shelving unit, 4-tier	18 x 36 x 74
518367C-5	Corner shelving unit, 5-tier	18 x 36 x 74
521367C	Corner shelving unit, 4-tier	21 x 36 x 74
521367C-5	Corner shelving unit, 5-tier	21 x 36 x 74
524427C	Corner shelving unit, 4-tier	24 x 42 x 74
524427C-5	Corner shelving unit, 5-tier	24 x 42 x 74
524428C	Corner shelving unit, 4-tier	24 x 42 x 86

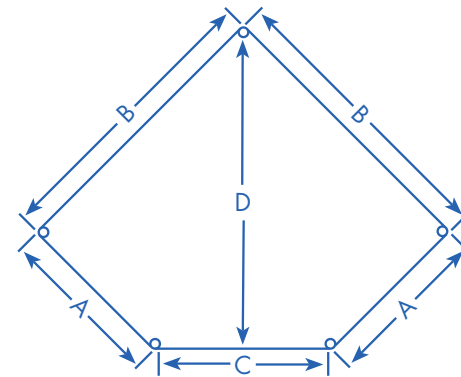

#### Corner Unit Components:

- Units can be combined with regular posts and casters.
- Design your own or add individual shelves to complete units.

MODEL #	DESCRIPTION	A	B	C	D
	<b>Corner Shelf</b>				
S51836C	Individual Corner Shelf 18" x 36"	18"	36"	24"	38"
S52136C	Individual Corner Shelf 21" x 36"	21"	36"	20"	40"
S52442C	Individual Corner Shelf 24" x 36"	24"	42"	24"	46"
AM1836PF-5	Corner Shelf Plastic Cover 18" x 36"	18"	36"	24"	38"
AM2136PF-5	Corner Shelf Plastic Cover 21" x 36"	21"	36"	20"	40"
AM2442PF-5	Corner Shelf Plastic Cover 24" x 42"	24"	42"	24"	46"
LH24BL	Blue Label Holder, 24"				



## Wire Shelving and Carts

**TSUN** is our premium wire shelving line: Smooth waterfall edge on front of shelf eliminates ripping of wrapped goods. Shelves adjust without any tools. Built-in endscreens. TSUN is also compatible with most standard wire accessories pages 31 - 37. A MUST FOR EVERY STERILE STORAGE AREA.

**TSUN**

### Complete TSUN Cart Consists of:



3 joining bars (1 at top back, 2 at bottom)

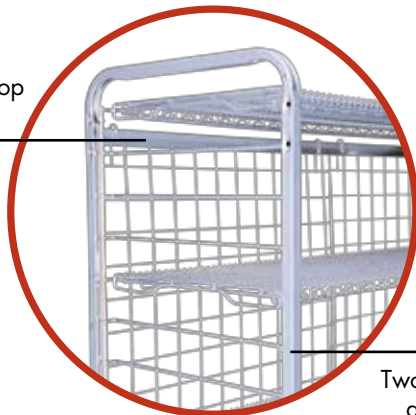

Two end frames function as enclosure panels

**Extra Accessories.** Others listed pages 31-37.

MODEL #	DESCRIPTION
	(inches)
TSUN2436-PL	TSUN Plastic Shelf Cover 24 x 36
TSUN2448-PL	TSUN Plastic Shelf Cover 24 x 48
TSUN2464-PL	TSUN Plastic Shelf Cover 24 x 64
TSUN2472-PL	TSUN Plastic Shelf Cover 24 x 72

### TSUN Complete Carts

MODEL #	DESCRIPTION	DIMENSIONS
		(inches)
TSUN2436-5SH-CL	Complete TSUN 5-Shelf Unit 24" x 36"	28 x 40 x 73
TSUN2448-5SH-CL	Complete TSUN 5-Shelf Unit 24" x 48"	28 x 52 x 73
TSUN2464-5SH-CL	Complete TSUN 5-Shelf Unit 24" x 64"	28 x 68 x 73
TSUN2472-5SH-CL	Complete TSUN 5-Shelf Unit 24" x 76"	28 x 76 x 73

MODEL #	DESCRIPTION
	(inches)
CFDIV246	Shelf Divider 6"
CFDIV248	Shelf Divider 8"
TSUN2436-SH	TSUN Wire Shelf 24" x 36"
TSUN2448-SH	TSUN Wire Shelf 24" x 48"
TSUN2464-SH	TSUN Wire Shelf 24" x 64"
TSUN2472-SH	TSUN Wire Shelf 24" x 72"

## Wire Shelving and Carts

### Plastic Solid Shelf Covers

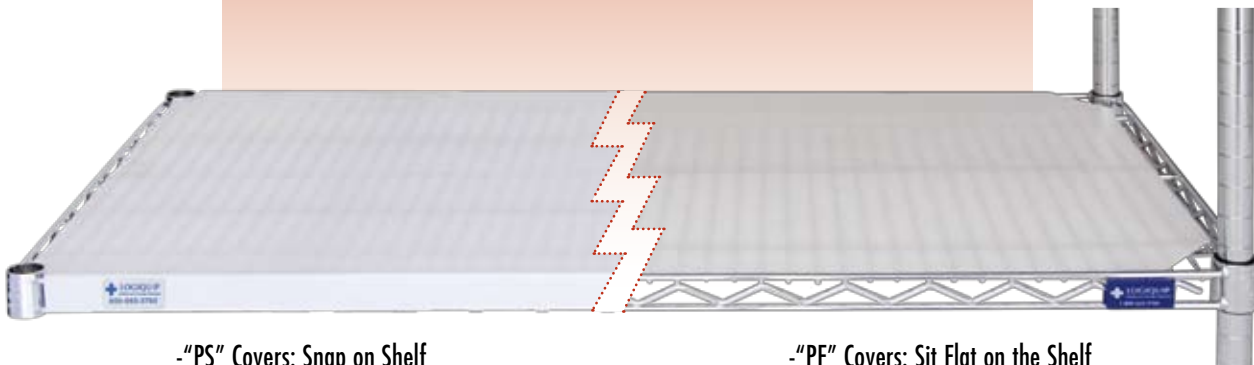

-“PS” Covers: Snap on Shelf

-“PF” Covers: Sit Flat on the Shelf

MODEL #	DESCRIPTION
	Snap On Plastic Shelf
AM1824PS	Snap On Plastic Shelf Cover 18" x 24"
AM1836PS	Snap On Plastic Shelf Cover 18" x 36"
AM1848PS	Snap On Plastic Shelf Cover 18" x 48"
AM1860PS	Snap On Plastic Shelf Cover 18" x 60"
AM1872PS	Snap On Plastic Shelf Cover 18" x 72"
AM2424PS	Snap On Plastic Shelf Cover 24" x 24"
AM2436PS	Snap On Plastic Shelf Cover 24" x 36"
AM2448PS	Snap On Plastic Shelf Cover 24" x 48"
AM2460PS	Snap On Plastic Shelf Cover 24" x 60"
AM2472PS	Snap On Plastic Shelf Cover 24" x 72"

MODEL #	DESCRIPTION
	Flat Plastic Shelf
AM1824PF	Flat Plastic Shelf Cover 18" x 24"
AM1830PF	Flat Plastic Shelf Cover 18" x 30"
AM1836PF	Flat Plastic Shelf Cover 18" x 36"
AM1842PF	Flat Plastic Shelf Cover 18" x 42"
AM1848PF	Flat Plastic Shelf Cover 18" x 48"
AM1854PF	Flat Plastic Shelf Cover 18" x 54"
AM1860PF	Flat Plastic Shelf Cover 18" x 60"
AM1872PF	Flat Plastic Shelf Cover 18" x 72"
AM2124PF	Flat Plastic Shelf Cover 21" x 24"
AM2130PF	Flat Plastic Shelf Cover 21" x 30"
AM2136PF	Flat Plastic Shelf Cover 21" x 36"
AM2142PF	Flat Plastic Shelf Cover 21" x 42"
AM2148PF	Flat Plastic Shelf Cover 21" x 48"
AM2160PF	Flat Plastic Shelf Cover 21" x 60"
AM2172PF	Flat Plastic Shelf Cover 21" x 72"
AM2424PF	Flat Plastic Shelf Cover 24" x 24"
AM2430PF	Flat Plastic Shelf Cover 24" x 30"
AM2436PF	Flat Plastic Shelf Cover 24" x 36"
AM2442PF	Flat Plastic Shelf Cover 24" x 42"
AM2448PF	Flat Plastic Shelf Cover 24" x 48"
AM2454PF	Flat Plastic Shelf Cover 24" x 54"
AM2460PF	Flat Plastic Shelf Cover 24" x 60"
AM2472PF	Flat Plastic Shelf Cover 24" x 72"

### Plastic Solid Shelf Covers

- White poly material.
  - Adhere to standards without heavy cost.
- \* Epoxy-coated and stainless steel shelf covers also available.

# Wire Shelving and Carts

## Cantilever Wall Shelf Units

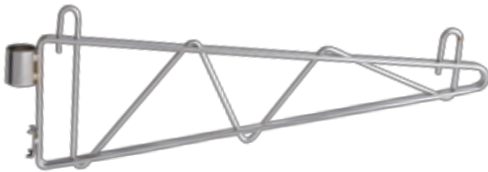

Cantilever Arm- Two per shelf in 14" or 18" depths



WMB-CH Wall-Mount Bracket.  
4 included with every set.

### One-Shelf Wall-Mount Complete Units consist of:

- Two posts 13"H.
- Four wall-mount brackets and two adjustable cantilever arms.
- One shelf (sizes below).

MODEL #	DESCRIPTION	D x W x H (OD)
	<b>One Shelf Wall-Mount Unit</b>	<b>(inches)</b>
1WA1424CH	One Shelf Wall-Mount Unit 14" x 24"	14 x 24 x 13
1WA1430CH	One Shelf Wall-Mount Unit 14" x 30"	14 x 30 x 13
1WA1436CH	One Shelf Wall-Mount Unit 14" x 36"	14 x 36 x 13
1WA1836CH	One Shelf Wall-Mount Unit 18" x 36"	18 x 36 x 13
1WA1848CH	One Shelf Wall-Mount Unit 18" x 48"	18 x 48 x 13

### Wall-Mount Shelving Units 1, 2 or 3-shelf configurations

- User must determine capability of wall to support fully loaded unit.
- Wall mounting bolts not included.



2WA1424CH

### Two-Shelf Wall-Mount Complete Units consist of:

- Two posts 24"H.
- Four wall-mount brackets and four adjustable cantilever arms.
- Two shelves (sizes below).

MODEL #	DESCRIPTION	D x W x H (OD)
	<b>Two Shelf Wall-Mount Unit</b>	<b>(inches)</b>
2WA1424CH	Two Shelf Wall-Mount Unit 14" x 24"	14 x 24 x 24
2WA1430CH	Two Shelf Wall-Mount Unit 14" x 30"	14 x 30 x 24
2WA1436CH	Two Shelf Wall-Mount Unit 14" x 36"	14 x 36 x 24
2WA1448CH	Two Shelf Wall-Mount Unit 14" x 48"	14 x 48 x 24
2WA1836CH	Two Shelf Wall-Mount Unit 18" x 36"	18 x 36 x 24
2WA1848CH	Two Shelf Wall-Mount Unit 18" x 48"	18 x 48 x 24



3WA1424CH

### Three-Shelf Wall-Mount Complete Units consist of:

- Two posts 36"H.
- Four wall-mount brackets and three adjustable cantilever arms.
- Three shelves (sizes below).

MODEL #	DESCRIPTION	D x W x H (OD)
	<b>Three Shelf Wall-Mount Unit</b>	<b>(inches)</b>
3WA1424CH	Three Shelf Wall-Mount Unit 14" x 24"	14 x 24 x 36
3WA1436CH	Three Shelf Wall-Mount Unit 14" x 36"	14 x 36 x 36
3WA1448CH	Three Shelf Wall-Mount Unit 14" x 48"	14 x 48 x 36
3WA1836CH	Three Shelf Wall-Mount Unit 18" x 36"	18 x 36 x 36
3WA1848CH	Three Shelf Wall-Mount Unit 18" x 48"	18 x 48 x 36



## Large Supply/Distribution

### Offsite Distribution Carts

These heavy-duty all-welded carts are designed for offsite JIT and stockless systems using a combination of shelves and totes. Ergonomic 6" casters standard.



BAX65



LEV-BC65

#### Model #AG663

- Fabricated from 1-1/4" aluminum tube frame with 3/4" round tube vertical closure.
- The base structure is supported from below with oversized caster mounting plates.
- 2" nylon seat belt webbing is fixed at the top and has velcro closures at the bottom.
- Standard 6" ergonomic casters, two fixed, two swivel.  
Add suffix "BFP" for 1 swivel, 2 swivel w/ brake, and 1 directional locking.  
Add suffix "R" for 2 fixed, 2 swivel.  
Add suffix "FP" for 1 directional locking.
- 6 non-marking corner bumpers.

MODEL #	D x W x H (O.D.)	WEIGHT
	(inches)	(lbs)
AG663	28 x 65 x 71.5	218

#### Distribution Containers, Flip Top, Nesting

- See cart descriptions for capacity.
- Polyethylene with textured bottoms, molded-in handle, padlock eye both ends, reinforced hinge pins.

MODEL #	D x W x H (O.D.)	COLORS
	(inches)	
9-453	21.5 x 15 x 12.5	Gray, Red, Blue, Green
9-593	24 x 20 x 12.5	Gray

#### Model # BAX65

- Fabricated from 1-1/4 (32mm) steel tube frame.
- Standard with # 31-76XSR ergonomic 6" casters, all swivel, 2 braking.  
Add suffix "BFP" for 1 swivel, 2 swivel w/ brake, and 1 directional locking.  
Add suffix "R" for 2 fixed, 2 swivel.  
Add suffix "FP" for 1 directional locking.
- Heavy-duty dolly base with wraparound bumper.
- Solid Stainless Steel bottom shelf. Shelves are sold separately #BAX65-SH.
- BAX65 will hold 16 each 9-453 containers and 12 each 9-593 containers.

MODEL #	D x W x H (O.D.)	WEIGHT
	(inches)	(lbs)
BAX65	26 x 66 x 65	182
BAX65-SH	Shelf for Small Runners	18
BAX65-SHL	Shelf for Large Runners	18

#### Model #LEV-BC65

- Base of 1" (25mm) square tube construction with wraparound bumper.
- Open side features nylon cargo net.
- Standard with # 31-76XSR ergonomic 6" casters, 2 brake, 2 swivel.  
Add suffix "BFP" for 1 swivel, 2 swivel w/ brake, and 1 directional locking.  
Add suffix "R" for 2 fixed, 2 swivel.  
Add suffix "FP" for 1 directional locking.
- Wire bottom shelf #LEVBC65-BS available.
- LEVBC65 Cart will hold 16 each 9-453 containers and 12 each 9-593 containers.

MODEL #	D x W x H (O.D.)	WEIGHT
	(inches)	(lbs)
LEV-BC65	28 x 68 x 75	218



AG663



9-453

9-593

\* More bins on page 83.

## Large Supply/Distribution

### Jug Transport Cart

#### Dialysis Jug Transport Cart

Solves one of the most challenging internal hospital logistics issues. Eliminates skids and outside cardboard in the clean supply area. Transports 100 jugs (4L) of solution at one time. Average load on cart: 1250 lbs. Use as an exchange cart - Switch empty cart with full. Configurable for towing.



Back of Cart



CTU-JUG48



Secure contents during transport with heavy-duty tubing

- Overall Dimensions: 28"D x 52"W x 68"H.
- Fully welded cart. Frames of 1-1/4" round tubing each end with vertical end rods 6" apart .
- Heavy-duty dolly base: Integrated c-channel with wrap-around bumper welded to steel plate frame.
- Solid stainless steel shelf insert in base for infection control.
- Three chrome wire shelves.
- Solid base and wire shelves to have 1" round tube 4" above the shelf on front and two 1" tubes at the back.
- 100-jug capacity. Each shelf will hold 20 each 4L jugs of solution.
- Heavy-duty ergonomic 6" casters, two fixed, two swivel. Other options (directional lock, etc.) also available.

## Large Supply/Distribution

### Enclosed Carts, Dolly Bases, 4-tier



MDES456CH-6

#### Standard Units Include:

- 4 each 63"H posts.
- 4 wire shelves with sleeves.
- Heavy-duty all-welded dolly fabricated with integral C-channel welded to steel plate frame.
- Non-marking wrap-around bumper.

Dolly is available open or closed, with premium epoxy coated solid insert or with stainless steel solid insert. Inserts adhere to infection control standards and function as solid bottom shelves which eliminates the additional wire shelf requirement.

#### Other Standard Sizes Available on Request:

- Depths: 18"
- Posts: 74"

#### Enclosed Cart with Open Dolly, 4 Wire Shelves.

D x W (inches)	WT. (lbs.)	5" PLATE CASTER Model #, Ht (in)	6" PLATE CASTER Model #, Ht (in)
24 x 36	184	MDE436CH 70	MDE436CH-6 71
24 x 48	224	MDE456CH 70	MDE456CH-6 71
24 x 60	273	MDE466CH 70	MDE466CH-6 71
24 x 72	323	MDE476CH 70	MDE476CH-6 71

\*Add the suffix "-CL" to model number for solid bottom shelf cover and 3 position label holders

\*Height is overall

#### Enclosed Cart with premium epoxy-coated Solid Insert Dolly, 4 Wire Shelves.

D x W (inches)	WT. (lbs.)	5" PLATE CASTER Model #, Ht (in)	6" PLATE CASTER Model #, Ht (in)
24 x 36	186	MDET436CH 70	MDET436CH-6 71
24 x 48	221	MDET456CH 70	MDET456CH-6 71
24 x 60	261	MDET466CH 70	MDET466CH-6 71
24 x 72	303	MDET476CH 70	MDET476CH-6 71

\*\*Add the suffix "-CL" to the model number for 3 position label holders for wire shelves only (solid bottom cover not required)

#### Enclosed Cart with Stainless Steel Solid Insert Dolly, 4 Wire Shelves.

D x W (inches)	WT. (lbs.)	5" PLATE CASTER Model #, Ht (in)	6" PLATE CASTER Model #, Ht (in)
24 x 36	186	MDES436CH 70	MDES436CH-6 71
24 x 48	221	MDES456CH 70	MDES456CH-6 71
24 x 60	261	MDES466CH 70	MDES466CH-6 71
24 x 72	303	MDES476CH 70	MDES476CH-6 71

\* Add the suffix "-CL" to the model number for 3 position label holders for wire shelves only (solid bottom cover not required)

#### 5" Caster Models:

- 4 each 5" plate-style swivel non-marking polyurethane casters, two with brakes.
- Weight capacity is 750 lbs. (each caster 250 lbs.)
- Recommended for non-transport "light-duty" applications.

#### 6" Caster "Heavy-Duty" Models:

- 4 each 6" premium ergonomic elastomere non-marking casters. All swivel, two with brakes.
- Rigid and directional-lock also available.  
Add suffix "BFP" for 1 swivel, 2 swivel w/ brake, and 1 directional locking.  
Add suffix "R" for 2 fixed, 2 swivel.  
Add suffix "FP" for 1 directional locking.
- 1200 lb weight capacity (each caster 400 lbs.)
- Recommended for "heavy-duty" transport applications.



## Large Supply/Distribution

### Enclosed Carts, Dolly Bases, 5 Tier

**Enclosed Cart** with Open Dolly, 5 Wire Shelves.

D x W	WT.	5" PLATE CASTER		6" PLATE CASTER	
(inches)	(lbs.)	Model #,	Ht (in)	Model #,	Ht (in)
24 x 36	200	MDE435CH	81	MDE435CH-6	82
24 x 48	243	MDE455CH	81	MDE455CH-6	82
24 x 60	297	MDE465CH	81	MDE465CH-6	82
24 x 72	352	MDE475CH	81	MDE475CH-6	82

\* Add the suffix "CL" to the model number for solid bottom shelf cover and 3 position label holder

**Enclosed Cart** with Dolly with premium epoxy-coated solid insert, 5 Wire Shelves.

D x W	WT.	5" PLATE CASTER		6" PLATE CASTER	
(inches)	(lbs.)	Model #,	Ht (in)	Model #,	Ht (in)
24 x 36	202	MDET435CH	81	MDET435CH-6	82
24 x 48	246	MDET455CH	81	MDET455CH-6	82
24 x 60	285	MDET465CH	81	MDET465CH-6	82
24 x 72	332	MDET475CH	81	MDET475CH-6	82

\*\* Add the suffix "CL" to the model number for 3 position label holders for wire shelves only (solid bottom cover not required)

**Enclosed Cart** with Dolly with Solid Stainless insert, 5 Wire Shelves.

D x W	WT.	5" PLATE CASTER		6" PLATE CASTER	
(inches)	(lbs.)	Model #,	Ht (in)	Model #,	Ht (in)
24 x 36	202	MDES435CH	81	MDES435CH-6	82
24 x 48	246	MDES455CH	81	MDES455CH-6	82
24 x 60	285	MDES465CH	81	MDES465CH-6	82
24 x 72	332	MDES475CH	81	MDES475CH-6	82

\* Add the suffix "CL" to the model number for 3 position label holders for wire shelves only (solid bottom cover not required)

#### Standard Units Include:

- 4 each 74"H posts.
- 5 wire shelves with sleeves.
- Enclosure panels of 3" x 3" wire mesh.
- Heavy-duty all-welded dolly fabricated with integral C-channel welded to steel plate frame. Non-marking wrap-around bumper.

Dolly is available open or closed, with tech-seal solid insert or with stainless steel solid insert. Inserts adhere to infection control standards and function as solid bottom shelves which eliminates the additional wire shelf requirement.

#### Other Standard Sizes Available on Request:

- Depths: 18"

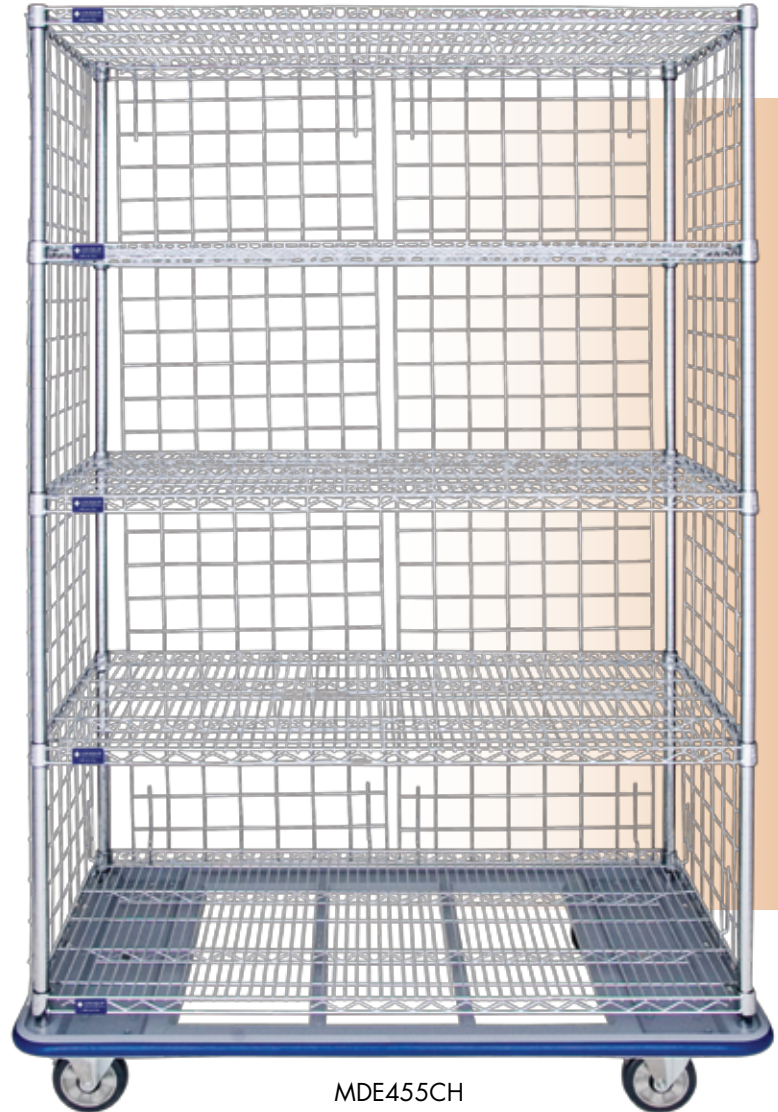

MDE455CH

#### 5" Caster Models:

- 4 x 5" plate-style swivel non-marking polyurethane casters, two with brakes.
- Weight capacity is 750 lbs. (each caster 250 lbs.)
- Recommended for non-transport "light-duty" applications.

#### 6" Caster "Heavy-Duty" Models:

- 4 x 6" premium ergonomic elastomere non-marking casters. All swivel, two with brakes.
- Rigid and directional-lock also available.
  - Add suffix "BFP" for 1 swivel, 2 swivel w/ brake, and 1 directional locking.
  - Add suffix "R" for 2 fixed, 2 swivel.
  - Add suffix "FP" for 1 directional locking.
- 1200 lb weight capacity (each caster 400 lbs.)
- Recommended for "heavy-duty" transport applications.

# Large Supply/Distribution

## Par Stor



310-III Complete Cart Shown with Optional Stainless Steel Worktop

### Open Par Carts:

- Designed for transport of sterile supplies. Holds standard Par Stor 16" x 24" baskets and tubs.
- Frame units do not include tubs or baskets. Accessories mounted on full-extension slides.
- All-welded 1" square tubular epoxy-coated steel frame.
- Sturdy base with solid shelf insert for infection control.
- 5" quiet poly swivel casters. Standard donut bumpers on corners.
- Accessories include dividers, label tags, nylon covers and solid stainless tops.

MODEL #	DESCRIPTION	D x W x H (overall)	SLOTS	MODEL #	TOP MODEL #
	Par Cart Frame	(inches)	#	Cart Cover	Solid Stainless
300-III	Single Short Par Cart Frame	29.5 x 25 x 43	30	PNC300-III	Top-Single-III
320-III	Double Short Par Cart Frame	29.5 x 44 x 43	60	PNC320-III	Top-Double-III
500-III	Single Medium Par Cart Frame	29.5 x 25 x 58.5	46	PNC500-III	Top-Single-III
520-III	Double Medium Par Cart Frame	29.5 x 44 x 58.5	92	PNC520-III	Top-Double-III
600-III	Single Tall Par Cart Frame	29.5 x 25 x 74.5	62	PNC600-III	Top-Single-III
620-III	Double Tall Par Cart Frame	29.5 x 44 x 74.5	124	PNC620-III	Top-Double-III
630-III	Triple Tall Par Cart Frame	29.5 x 65 x 74.5	186	PNC630-III	Top-Triple-III

### Build Your Own Par Cart:

- Refer to the number of available slots in the table above.
- Table below indicates how many slots each basket/tub/shelf occupies.

DESCRIPTION	SLOTS	DESCRIPTION	SLOTS
	#		#
3" Basket	4	3" Tub	5
5" Basket	6	5" Tub	7
8" Basket	9	8" Tub	10
Slanted 3" Basket or Tub	7	Chrome Wire Shelf	2

\* See Accessories on Page 16.



6200-III



PS620-III Container Cart



505-III Complete Cart

### "Complete" Par Carts:

- Our most popular configurations in ready-to-order format.

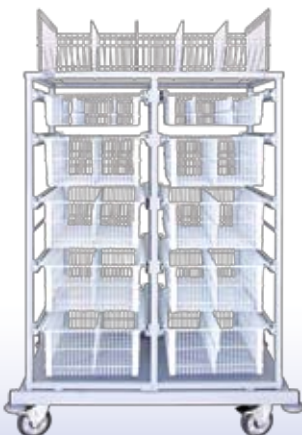

520IV-III IV Cart

MODEL #	DESCRIPTION	D x W x H (O.D.)
		(inches)
310-III	Preconfigured single short par cart with stainless steel top. 1 - 3", 2 - 5", 1 - 8" baskets	29.5 x 25 x 43
505-III	Preconfigured single medium par cart. 1 - 3", 4 - 5", 1 - 8" baskets	29.5 x 25 x 58.5
605-III	Preconfigured single tall par cart. 1 - 3", 6 - 5" baskets	29.5 x 25 x 74.5
500IV-III	IV Cart. 1 - 5", 2 each long /short divider, 4 - 8", 2 long divider each	29.5 x 25 x 58.5
500IV-III-KP	IV Cart. 4 - 8" baskets each with 2 long dividers/basket	29.5 x 25 x 58.5
520IV-III	2 - 5", 2 long dividers each, 8 - 8", 1 long divider each	29.5 x 44 x 58.5
520IV-III-KP	8 - 8" baskets each with 2 long dividers. 24 each LH-3 label tags	29.5 x 44 x 58.5
PS620-III	14 each waterfall-edge chrome wire shelves	29.5 x 44 x 74.5
6200-III	7 each waterfall-edge chrome wire shelves and 7 - 5" baskets	29.5 x 44 x 74.5

## Large Supply/Distribution

### Par Stor

#### Enclosed Par Carts:

- Transport sterile supplies in an enclosed cart. Ideal for non-dedicated delivery systems.
- Holds standard Par Stor 16" x 24" baskets and tubs.
- Units do not include tubs or baskets. Accessories mounted on full-extension slides.
- All-welded 1" square tubular epoxy-coated steel frame.
- Frame enclosed in blue epoxy-coated steel.
- 3/8" plastic clear door with 3 hospital-grade hinges and chrome handle.
- Sturdy base with solid shelf insert for infection control.
- 5" quiet poly swivel casters. Standard donut bumpers on corners.
- Accessories include dividers and label tags. See page 16.

MODEL #	DESCRIPTION	D x W x H (overall)	SLOTS
	Par Cart Frame	(inches)	(number of)
500EN-III	Single Enclosed Medium Par Cart Frame	29.5 x 25 x 58.5	46
520EN-III	Double Enclosed Medium Par Cart Frame	29.5 x 44 x 58.5	92
600EN-III	Single Enclosed Tall Par Cart Frame	29.5 x 25 x 74.5	62
620EN-III	Double Enclosed Tall Par Cart Frame	29.5 x 44 x 74.5	124

#### Build Your Own Enclosed Par Cart:

- Refer to the number of available slots in the table above.
- Table below indicates how many slots each basket/tub/shelf occupies.

DESCRIPTION	SLOTS
	# of Occupied
3" Basket	4
5" Basket	6
8" Basket	9
Slanted 3" Basket or Tub	7

DESCRIPTION	SLOTS
	# of Occupied
3" Tub	5
5" Tub	7
8" Tub	10
Chrome Wire Shelf	2

\* See Accessories on Page 16.



620EN-III w/ Example Basket Set



500EN-III w/ Example Basket Set

#### "Complete" Enclosed Par Carts:

- Our most popular configurations in ready-to-order format.

MODEL #	DESCRIPTION	D x W x H (O.D.)
		(inches)
505EN-III	Preconfigured single medium par cart. 1 - 3", 4 - 5", 1 - 8" baskets	29.5 x 25 x 58.5
605EN-III	Preconfigured single tall par cart. 1 - 3", 6 - 5" baskets	29.5 x 25 x 74.5
500IV-EN-III	IV Cart. 1 - 5", 2 each long /short divider, 4 - 8", 2 long divider each	29.5 x 25 x 58.5
500IV-EN-III-KP	IV Cart. 4 - 8" baskets each with 2 long dividers/basket	29.5 x 25 x 58.5
520IV-EN-III	2 - 5", 2 long dividers each, 8 - 8", 1 long divider each	29.5 x 44 x 58.5
520IV-EN-III-KP	8 - 8" baskets each with 2 long dividers. 24 each LH-3 label tags	29.5 x 44 x 58.5
6200CONT-EN-III	14 each waterfall-edge chrome wire shelves	29.5 x 44 x 74.5
6200ORTH-EN-III	7 each waterfall-edge chrome wire shelves and 7 - 5" baskets	29.5 x 44 x 74.5



# Large Supply Carts

## Exchange/Par Level/OR Drawer Carts with Shelves



CVTU6040

Add suffix "BFP" for 1 swivel, 2 swivel w/ brake, and 1 directional locking.  
 Add suffix "R" for 2 fixed, 2 swivel.  
 Add suffix "FP" for 1 directional locking.

### Tubular Carts for In House Exchange/Transport

- 1-1/4" tube all welded frame. Dolly base with wraparound bumper and stainless bottom shelf.
- 3 adjustable nickel chrome wire shelves (adjustable without tools). CVTU4840: 21" x 30" shelves CVTU6040: 21" x 42" shelves.
- Full-length top wire shelf: CVTU4840: 21" x 48" CVTU6040: 21" x 60"
- Side shelf rungs function as end screens.
- Back screen 3"x3" (76x76mm) mesh.
- Full-length label holders all shelves.
- 4 - 6" heavy-duty ergo casters: 2 swivel, 2 brake. Directional lock and brake available.
- Plastic Drawer Cart: 7 drawers each 17" x 22" x 6"H (dividers: 1 long, 2 short and index pockets included).
- Wire Basket Cart: 7 chrome baskets each 16" x 24" x 5"H (dividers: 1 long, 2 short and 30 label tags #LH-3 included)

MODEL #	DESCRIPTION	D x W x H	WEIGHT
	<b>Tubular Exchange Cart</b>	<b>(inches)</b>	<b>(lbs.)</b>
CVTU4840	Tubular exchange cart with plastic drawers	24 x 54 x 66	184
CVTU6040	Tubular exchange cart with plastic drawers	26 x 66 x 66	205
CVTU4840-WB	Tubular exchange cart with wire baskets	24 x 54 x 66	184
CVTU6040-WB	Tubular exchange cart with wire baskets	26 x 66 x 66	205

### Tubular Par-Level Carts For Stationary Top-Up

- 1 - 1/4" tube all welded frame.
- 3 adjustable nickel chrome wire shelves (adjustable without tools). SVTU5040: 21" x 42" shelves, SVTU7040: 21" x 60" shelves.
- Full-length top wire shelf: SVTU5040: 21" x 60" SVTU7040: 21" x 72".
- Solid stainless steel base shelf (adjustable without tools).
- Back screen 3"x3" (76x76mm) mesh. Shelf rungs function as end screens.
- Full-length label holders all shelves.
- 4 - 5" casters: 2 swivel, 2 rigid.
- Plastic Drawer Cart: 7 drawers each 17" x 22" x 6"H (dividers: 1 long, 2 short and index pockets included)
- Wire Basket Cart: 7 chrome baskets each 16" x 24" x 5"H (dividers: 1 long, 2 short and 30 label tags #LH-3 included)



CVTU6040WB



SVTU7040

MODEL #	DESCRIPTION	D x W x H	WEIGHT
	<b>Tubular Exchange Cart</b>	<b>(inches)</b>	<b>(lbs.)</b>
SVTU5040	Tubular top-up cart with plastic drawers	24 x 63 x 66	184
SVTU7040	Tubular top-up cart with plastic drawers	24 x 78 x 66	205
SVTU5040-WB	Tubular top-up cart with wire baskets	24 x 63 x 66	184
SVTU7040-WB	Tubular top-up cart with wire baskets	24 x 78 x 66	205

## Large Supply Carts

### Drawer Carts and Exchange Carts without Drawers

#### Tubular Shelf Distribution Carts for In House Transport

Designed for exchange/transport cart purposes within the hospital.

- 1-1/4" tube all welded frame. Dolly base with wraparound bumper and stainless bottom shelf.
- 4 adjustable nickel chrome wire shelves (adjustable without tools). CTU48: 21" x 48". CTU60: 21" x 60" shelves.
- Side shelf rungs function as end screens.
- Back screen 3"x3" (76x76mm) mesh.
- Full-length label holders all shelves.
- 4 - 6" heavy-duty ergo casters: All swivel two with brakes.

MODEL #	DESCRIPTION	D x W x H (inches)	WEIGHT (lbs.)
	<b>Tubular Exchange Cart</b>		
CTU48	Tubular exchange cart	24 x 54 x 66	145
CTU60	Tubular exchange cart	26 x 66 x 66	169



CTU60



DRAW14



DRAW7

#### Plastic Drawer Distribution Carts for In House Transport

Designed for exchange/transport of small items within the hospital.

- 1-1/4" tube all welded frame. Dolly base with wraparound bumper.
- 4-6" heavy-duty ergo casters: All swivel, two with brakes. Directional lock brake available.
- Drawers each 17" x 22" x 6"H (dividers: 1 long, 2 short and index pockets included).

MODEL #	DESCRIPTION	D x W x H (inches)	WEIGHT (lbs.)
	<b>Tubular Drawer Cart</b>		
DRAW7	Tubular drawer cart with 7 drawers	26 x 22 x 56	95
DRAW14	Tubular drawer cart with 14 drawers	45 x 22 x 56	155
DRAW21	Tubular drawer cart with 21 drawers	64 x 22 x 56	220

#### IV Exchange/Distribution Carts for In House Transport

Designed for exchange/transport of solutions within the hospital.

- 1-1/4" tube all welded frame. Dolly base with wraparound bumper.
- Sloped chrome baskets. Each basket to have 2 dividers and label holders.
- Plastic drawers each 17" x 22" x 6"H (dividers: 1 long, 2 short and index pockets included).
- 4-6" heavy-duty ergo casters: All swivel, two with brakes. Directional lock brake available.

MODEL #	DESCRIPTION	D x W x H (inches)	WEIGHT (lbs.)
	<b>Tubular IV Cart</b>		
IV-2424	Tubular IV Cart- 3 baskets/1 drawer	26 x 26 x 69	85
IV-2445	Tubular IV Cart- 6 baskets/2 drawers	42 x 26 x 69	150
IV-2463	Tubular IV Cart- 9 baskets/3 drawers	63 x 26 x 69	220



IV-2445

IV-2424

Add suffix "BFP" for 1 swivel, 2 swivel w/ brake, and 1 directional locking.

Add suffix "R" for 2 fixed, 2 swivel.

Add suffix "FP" for 1 directional locking.

# Large Supply Carts

## Tubular Accessories



TU48R

**Tubular Shelves** Add extra shelves to your carts. Nickel-plated chrome wire.

MODEL #	D x W x H (inches)	FITS CART(S)
TU30R	21 x 29	CVTU4840
TU42R	21 x 41	CVTU6040, SVTU5040
TU48R	21 x 47	CTU48
TU60R	21 x 59	SVTU7040, CTU60



TL48

**Tubular Shelf Ledges** Prevent items from falling off the cart. Nickel-plated chrome wire.

MODEL #	D x W x H (inches)	FITS CART(S)
TL303	21 x 29	CVTU4840
TL423	21 x 41	CVTU6040, SVTU5040
TL483	21 x 47	CTU48
TL603	21 x 59	SVTU7040, CTU60



R146

**Label Holders** Identify items. Flat-face full-length blue plastic.

MODEL #	D x W x H (inches)	FITS CART(S)
F128	21 x 28	CVTU4840
F140	21 x 40	CVTU6040, SVTU5040
F146	21 x 46	CTU48
F158	21 x 58	SVTU7040, CTU60



B5-III-CH shown with dividers

### Wire Basket Dividers

MODEL #	DESCRIPTION
B5DL-III-CH	Long divider for medium basket
B5DS-III-CH	Short divider for medium basket
LH3	Label tag for medium basket 1" x 3"
BCHFR	Mounting frame for medium basket

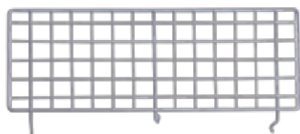

CFDIV186

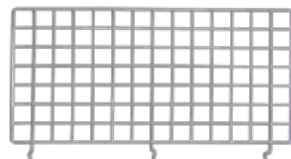

CFDIV188

**Wire Shelf Dividers**  
Nickel-chrome plated wire. Bottom 3-hook design fits all standard wire shelves. 6" and 8" heights.

MODEL #	D x W x H (inches)
CFDIV186	18 x 6
CFDIV188	18 x 8



DV17/D6DS



DV22/D6DL

### Plastic Drawer (TB40) Dividers

MODEL #	DESCRIPTION	PKG OF
DV22 / D6DL	Long divider (max 11 per drawer)	6
DV17 / D6DS	Short divider (max 15 per drawer)	6
TB40IL	Insert lid for TB40	



## Large Supply Carts

### LogiCell and Big White Box

LogiCell® Supply Carts are designed for enclosed sterile storage either in the OR or Cath Lab. Here is a glimpse of our product offerings. For more information on LogiCell® visit <http://www.logiquip.com/logicell> or call for a full color catalog.

#### Standard LogiCell® Features

- Constructed in 20-gauge textured epoxy coated steel with Frosty White finish
- Cell system of plastic side panels accommodates a range of accessories (16-22 -usable cells per column).
- Standard Tambour door with cassette design.
- Double carts available with hinged glass doors of durable aluminum with hospital-grade safety glass. Add suffix -HG
- Tubular handle on both ends. Wrap-around bumper. 5" swivel casters, two with brakes. Caster upgrade to 6" ergonomic available.
- Tall Double Cart Dimensions: 40"W x 28"D x 80"H.
- 3/4 Double Cart Dimensions: 40"W x 28"D x 63.75"H.
- Tall Triple Cart Dimensions: 57"W x 28"D x 80"H.



26527HG  
Three-Quarter Double Cart Shown with "HG"  
Glass Doors and Accessory Baskets



Cart Shown with  
BWB36KIT1 Par Wall Kit  
(above and right)

#### The "Big White Box" Par Wall® in an Enclosed Lockable System

- 18"D x 36"W x 78"H.
- Epoxy-coated steel fabrication.
- Clear, Impact-Resistant Acrylic Doors.
- Louvered panel back wall. Epoxy-coated steel panel accepts Par Wall baskets or plastic bins (page 86).
- Key lock handle.
- Push handle.
- 4 x 5" poly swivel casters, two with brakes.
- Minimal assembly required (attaching door handles, push handle and casters).
- Model #BWB36HG: Cart with louvered panel. No baskets/bins included.
- Model #BWB36KIT1 : Par Wall Kit for Big White Box Cart. Consists of
  - 8 x 12"D x 36"W fine-mesh Par Wall baskets (Model #PFW1236FM)
  - 8 x Flat-face full-length label holders (Model #PFLH36)
  - 40 x Front/back fine mesh chrome dividers 12"D x 6"H (Model #DWW126FM)

## Utility Carts

### Wire Carts

#### Wire Utility Carts:

- 2 U-handle/posts 40"H.
- 2 or 3 wire shelves.
- Chrome Finish: Heavy nickel plating with hard chromium finish excellent for dry storage hospital applications.
- Duro Seal: Clear, heavy-coat finish over chrome, that is suitable for more high-humidity applications. 10-year warranty against rust.
- 4-5" swivel casters with donut bumpers, two with brakes.
- Shipped unassembled.



RD284CH

#### 2 Shelf

D x W x H	DESCRIPTION	CHROME	DURO SEAL
(inches)	2 Shelf	Model #	Model #
18 x 24 x 40	2-Shelf Utility Cart	RD282CH	RD282PW
18 x 30 x 40	2-Shelf Utility Cart	RD283CH	RD283PW
18 x 36 x 40	2-Shelf Utility Cart	RD284CH	RD284PW
18 x 42 x 40	2-Shelf Utility Cart	RD285CH	RD285PW
18 x 48 x 40	2-Shelf Utility Cart	RD286CH	RD286PW
24 x 30 x 40	2-Shelf Utility Cart	RD243CH	RD243PW
24 x 36 x 40	2-Shelf Utility Cart	RD244CH	RD244PW
24 x 42 x 40	2-Shelf Utility Cart	RD245CH	RD245PW
24 x 48 x 40	2-Shelf Utility Cart	RD246CH	RD246PW

**Single Push Handle with opposing 30" post available.  
Substitute "C" for "RD" in Model # C382CH.**

#### 3 Shelf

D x W x H	DESCRIPTION	CHROME	DURO SEAL
(inches)	3 Shelf	Model #	Model #
18 x 24 x 40	3-Shelf Utility Cart	RD382CH	RD382PW
18 x 30 x 40	3-Shelf Utility Cart	RD383CH	RD383PW
18 x 36 x 40	3-Shelf Utility Cart	RD384CH	RD384PW
18 x 42 x 40	3-Shelf Utility Cart	RD385CH	RD385PW
18 x 48 x 40	3-Shelf Utility Cart	RD386CH	RD386PW
24 x 30 x 40	3-Shelf Utility Cart	RD343CH	RD343PW
24 x 36 x 40	3-Shelf Utility Cart	RD344CH	RD344PW
24 x 42 x 40	3-Shelf Utility Cart	RD345CH	RD345PW
24 x 48 x 40	3-Shelf Utility Cart	RD346CH	RD346PW



C384CH

## Utility Carts

### Wire Utility Cart + Accessories

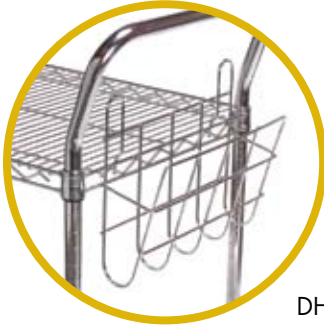

DH



HB916



AM2448PF Flat Plastic Shelf Liner

**Wire Document/Chart Holder** Attaches to shelf.

D x W x H	WT.	DESCRIPTION	MODEL #
(inches)	(lbs.)		
12.375 x 2 x 8.625	2	Document Holder	DH

**Wire Baskets:** Add-On.

D x W x H	WT.	DESCRIPTION	MODEL #
(inches)	(lbs.)		
7 x 15 x 7	2.3	Add-On Basket	HB715
9 x 16 x 9	4	Add-On Basket	HB916

### Flat Plastic Shelf Liners

D x W	DESCRIPTION	MODEL #
(inches)		
18 x 36	Flat Plastic Shelf Liner	AM1836PF
18 x 48	Flat Plastic Shelf Liner	AM1848PF
24 x 36	Flat Plastic Shelf Liner	AM2436PF
24 x 48	Flat Plastic Shelf Liner	AM2448PF

Replace Suffex PF with SS for Stainless Steel Option



AM2448PS Snap-On Shelf Cover

### "PS" White Poly Covers

D x W	DESCRIPTION	MODEL #
(inches)		
18 x 24	Snap-On Plastic Shelf Cover	AM1824PS
18 x 36	Snap-On Plastic Shelf Cover	AM1836PS
18 x 48	Snap-On Plastic Shelf Cover	AM1848PS
24 x 36	Snap-On Plastic Shelf Cover	AM2436PS
24 x 48	Snap-On Plastic Shelf Cover	AM2448PS

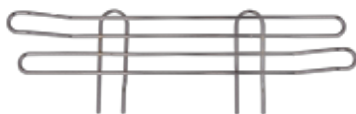

L184CH



L364CH

**Side and Back Ledges 4" Height.**

WIDTH	WT.	CHROME	DURO SEAL
(inches)	(lbs.)	Model #	Model #
18	1	L184CH	L184PW
24	2	L244CH	L244PW
30	2	L304CH	L304PW
36	2.5	L364CH	L364PW
42	2.5	L424CH	L424PW
48	3	L484CH	L484PW

**Side and Back Ledges 1" Height.**

WIDTH	WT.	CHROME	DURO SEAL
(inches)	(lbs.)	Model #	Model #
18	0.5	L181CH	L181PW
24	1	L241CH	L241PW
30	1	L301CH	L301PW
36	1.5	L361CH	L361PW
42	1.5	L421CH	L421PW
48	2	L481CH	L481PW



# Utility Carts

## Stainless Carts



3060

### Stainless Steel Angle Leg Carts: 3-Shelf

Ideal for constant usage with light to moderate loads. Available in 200 lb. and 400 lb. capacity. In stock, ships ready to use.

- All rubber swivel casters standard.
- Durable chassis frame with protective bumpers on legs and handles.
- All welded construction.
- Swivel casters with ball bearings for easy control.
- Sound deadened shelves for silent cart use.

### Angle-Leg Utility Carts: 3-Shelf

OVERALL SIZE	SHELF SIZE	SHELF CLEARANCE	CAPACITY	CASTER SIZE	WEIGHT	MODEL#
W x L x H (inches)	(inches)	(inches)		(inches)	(lbs.)	
16-1/4 x 27-1/2 x 32-1/8	15-1/2 x 24	11-3/4	300	3-1/2	29	3060
18-3/8 x 30-3/4 x 33	18 x 27	12-1/4	300	3-1/2	32	3061
16-3/4 x 27-5/8 x 33-3/6	15-1/2 x 24	11-7/8	500	4	39	3065
19 x 31 x 33-3/8	18 x 27	11-7/8	500	4	42	3066
22-3/8 x 39-1/4 x 37-1/4	21 x 35	13-1/8	500	5	68	3067

### Stainless Steel Guard Rail Carts: 2 and 3-Shelf

Perfect for use in areas with sharp turns or inclines. These sturdy carts are equipped with a 2" edge on sides and back with a guard rail on the front.

- Guard rail design protects against breakage and spillage and provides for easy cleaning.
- All 5" caster models have our featured shock-absorbing springlide casters for smooth transport on tiled or uneven floors.
- All rubber swivel casters.
- All welded construction.



3080

### Guard Rail Utility Carts: 2 and 3-Shelf

OVERALL SIZE	SHELF SIZE	SHELF CLEARANCE	# OF SHELVES	CAPACITY	CASTER SIZE	WEIGHT	MODEL#
W x L x H (inches)	(inches)	(inches)	Quantity		(inches)	(lbs.)	
16-14 x 27-1/2 x 32-1/8	15-1/2 x 24	9-1/4	3	200	3-1/2	33	3080
18-3/8 x 30-3/4 x 33	18 x 27	9	3	400	4	45	3081
19-3/8 x 32-5/8 x 34-1/2	18 x 27	17	2	650	5	56	3082-2
19-3/8 x 32-5/8 x 34-1/2	18 x 27	19	3	650	5	66	3082
22-3/8 x 38-5/8 x 37-1/4	21 x 33	18-3/4	2	650	5	65	3083-2
22-3/8 x 39-1/4 x 37-1/4	21 x 33	9-3/8	3	650	5	79	3083

## Utility Carts

### Equipment Stands

#### Stainless Equipment Stands

- These versatile mobile tables and stands smoothly move delicate equipment and serve as treatment centers.
- All models feature welded stainless steel construction.
- Mobile stands occupy minimum floor space.
- Plastic tray insert is standard on all drawer models.
- Optional key lock is available on drawer models.



359/469



474



356/466

SHELF SIZE	OVERALL SIZE	CLEARANCE BETWEEN SHELVES	STAINLESS STEEL TOP	STAINLESS STEEL LEGS	DIA. OF CASTERS	SHIPPING WT	MODEL#
(inches)	D x W x H (inches)	(inches)	Gauge	Gauge	(inches)	(lbs.)	
16-5/8 x 18-3/8	16 x 18 x 30-1/8	8-1/8	22	16	3 all swivel	39lbs	356
16-5/8 x 18-3/8	16 x 18 x 35	17-1/8	22	16	3 all swivel	44lbs	358
16-5/8 x 18-3/8	16 x 18 x 30-1/8	10-3/4	22	20	3 all swivel	27lbs	359
16-5/8 x 18-3/8	16 x 18 x 31	8-1/8	20	16	4 all swivel	50lbs	466
16-5/8 x 18-3/8	16 x 18 x 31	10-3/4	20	16	4 all swivel	33lbs	469
20 x 36	20-1/8 x 36-3/8 x 35	10	20	16	4 all swivel	80lbs	474

## Utility Carts

### Plastic Carts



4520-88 with 4598 shelf



4500-88



4520-10



4546-10

D x W x H (inches)	DESCRIPTION	SHELVES Quantity	CAPACITY (lbs)	CASTERS (inches)	MODEL #
17.8 x 39 x 33.25	Heavy-Duty Utility Cart (Small)	2	500	4 x 5, 2 fixed, 2 swivel	4500-88
16.8 x 30.75 x 3.4	Extra Middle Shelf for 4500-88	-	200		4597
25.8 x 45.25 x 33.25	Heavy-Duty Utility Cart (Medium)	2	500	4 x 5, 2 fixed, 2 swivel	4520-88
25.8 x 45.25 x 37.2	Heavy-Duty Utility Cart with Pneumatic Casters (Medium)	2	500	4 x 8, 2 fixed, 2 swivel	4520-10
24.8 x 36.8 x 3.4	Extra Middle Shelf for 4520-88 and 4520-10	-	200		4598
26 x 55 x 33.25	Heavy-Duty Utility Cart (Large)	2	750	4 x 5, 2 fixed, 2 swivel	4546
26 x 55 x 33.25	Heavy-Duty Utility Cart with Pneumatic Casters (Large)	2	750	4 x 8, 2 fixed, 2 swivel	4546-10



4505

#### Flat Shelf Service Cart

- Durable high-density structural resin construction.
- Ergonomically designed push handle.
- 4 x 5" casters; two fixed, two swivel.
- Assembly Required.
- 500 capacity.
- Available in 2-shelf only.
- Specify Black or Beige.



## Utility Carts

### Plastic + Aluminum Carts



2000



3355



3421

#### Lighter Duty Service Carts

- Smooth, easy-to-clean shelves.
- 150-300 lb. capacity.
- Many colors and styles available.
- Assembly Required.



3424



3457

D x W x H (inches)	DESCRIPTION	SHELVES Quantity	CAPACITY (lbs)	CASTERS (inches)	COLOR(s)	MODEL #
17.1 x 32.5 x 35	Light Duty Utility Cart	3	150	4 x 4 swivel	Beige	2000
18 x 31 x 37.5	Utility Cart with Enclosed End Panels	3	300	4 x 4 swivel	Platinum	3355-88
18.5 x 33.5 x 36.5	Utility Cart with Enclosed End Panels	3	150	4 x 3 swivel	Platinum, Black	3421
18.5 x 33.5 x 37.75	Utility Cart with Aluminum Uprights	3	200	4 x 4 swivel	Platinum, Blk., Red, Wht.	3424-88
18.5 x 33.5 x 37.75	Utility Cart with Lockable Doors, Sliding Drawer	2	200	4 x 4 swivel	Black	3457



4091



4092



4093



4094



4096



4095

D x W x H (inches)	DESCRIPTION	SHELVES quantity	COLOR(s)	MODEL #
20 x 40.5 x 37.8	Utility Cart, Open Sided	3	Gray, White, Black	4091
20 x 40.5 x 37.8	Utility Cart with Enclosed End Panels	3	White with Gray Panels	4092
20 x 40.5 x 37.8	Utility Cart with Enclosed End Panels- Three Sides	3	White, Black	4093
20 x 40.5 x 37.8	Utility Cart with Lockable Doors, Sliding Drawers	3	Gray	4094
20 x 40.5 x 37.8	Utility Cart with Lockable Doors	3	Black	4095
20 x 40.5 x 51	Tall Utility Cart, Open Sided	4	Black	4096

#### Plastic/Aluminum Carts

- Smooth, easy-to-clean shelves.
- Ergonomic easy grip handles with brushed aluminum uprights.
- 300 lb capacity all carts.
- Assembly Required.

# Utility Carts

## Mail Carts

L x D x H (inches)	WT (lbs.)	DESCRIPTION	MODEL #
29 x 19.5 x 37	24	Cart w/ 1-6", 1-12" Basket	CA5
24 x 14 x 6	10	6"H Basket only	CA6
24 x 14 x 12	10	12"H Basket only	CA12

### Basket Carts:

- Nickel chrome plated X-frame.
- White powdered coat steel baskets.
- 3" rubber wheel, ball bearing swivel casters.
- 50 lb. capacity.
- Ideal for smaller items.
- Assembly Required.



CA5

### Mail Carts:

Designed for internal/external mail distribution, add file separators to create slots for each call point. Chrome finish, 3/4" tubular frame, chrome wire baskets. Only top basket has file supports, Bottom basket for boxes. Assembly required.



LQ-2DCR

NOMINAL SIZE (inches)	WT (lbs.)	DESCRIPTION	MODEL #
32 x 20 x 37	42	Complete Cart. 1-11", 1-7" Basket.	LQ-2DCR
25 x 18 x 11	8	Top Basket	LQ-3CR
25 x 18 x 7	6	Bottom Basket	LQ-4CR

- Holds up to 80 legal size folders.
- 4-5" casters (127mm) 2 swivel, 2 rigid with brakes.
- Donut bumpers included.



LQ-2DOLF

NOMINAL SIZE (inches)	WT (lbs.)	DESCRIPTION	MODEL #
22 x 45 x 38	60	Complete Cart. 1-12", 1-10" Basket.	LQ-2DOLF
17 x 37 x 12	12	Top Basket	LQ-2BTOLF
17 x 37 x 7	10	Bottom Basket	LQ-2BBOLF

- Holds up to 120 legal size folders.
- 4-5" casters (127mm) 2 swivel, 2 rigid.
- Donut bumpers included.

NOMINAL SIZE (inches)	WT (lbs.)	DESCRIPTION	MODEL #
32 x 20 x 37	65	Complete Cart. 1-12", 1-10" Basket.	LQ-2DOLF10
25 x 18 x 11	12	Top Basket	LQ-2BTOLF
25 x 18 x 7	10	Bottom Basket	LQ-2BBOLF

- Holds up to 120 legal size folders.
- 2-5" swivel casters (front). 2-10" rigid casters (back).
- Donut bumpers optional.

## Utility Carts

### Pick Carts + Mail Carts



5141

#### Pick Carts - One Basket:

- Overall Dimensions: 22-1/2"D x 20"W x 39-1/2"H.
- Basket Dimensions: 17-1/2"D x 16-1/4"W (14"W at front) x 8"H.
- Epoxy-Coated Steel Fabrication.
- Ergonomically designed push handle at 39-1/2"H.
- Two fixed, two swivel 5" casters.
- "Nest" for great space saving.
- Weight: 30 lbs.
- Standard color: Gray.
- Model #5141

#### Pick Carts- Two Baskets:

- Overall Dimensions: 27-1/2"D x 20-1/2"W x 39-1/2"H.
- Basket Dimensions: 17-1/2"D x 16-1/4"W x 8"H.
- Bottom Basket Dimensions: 17-1/2"D x 16-1/4"W x 4"H.
- Epoxy-Coated Steel Fabrication.
- Ergonomically designed push handle at 39-1/2"H.
- Two fixed, two swivel 5" casters.
- "Nest" for great space saving.
- Weight: 39 lbs.
- Standard color: Gray.
- Model #5341



5341



909

#### Stock Cart:

- Overall Dimensions: 18"D x 44"W x 37"H.
- Epoxy-Coated Steel Fabrication.
- Ergonomically designed push handle at 39-1/2"H.
- Two fixed, two swivel 5" casters.
- Weight: 600 lbs.
- Standard color: Gray.
- Model #909



## Specialty Products

### Warming Cabinets



SWC36-G

#### Options

- Full view glass door.
- Mobile dolly or cart.
- 18" depth.
- Full recess.
- Pass through chamber.
- Left hand door hinge.
- Keyed door lock.
- Temperature recorder.
- Seismic brackets.
- 220/240V, 50/60HZ.
- Custom sizes.

#### Warming Cabinet

#### Standard Features and Specifications

- Digitally Controlled Heating Chambers. Fully Insulated.
- Displays actual temperature and set point at all times.
- Locking temperature set point. Audible and Visual Over/UnderTemp Alarm.
- Heat Control Accuracy to +/- 1 Degree F. Uniform Heating.
- Rapid Warm Time (2-6 hours depending on load).
- Heating Range 90 — 160 Degrees F.
- U.L. / C.U.L. approved. FDA registered OSHPD pre-approved.



SWC1824



SWC24-G

#### Counter-Top Cabinets Compact

Model# SWC1824-G: Glass Door  
Model# SWC1824: Stainless Steel Door

- Compartment Size: 3.0 cubic ft.
- 20"W x 17"D x 15.25"H.
- Overall Size: 24"W x 20.5"D x 24.5"H.
- Electrical: 120V, 3.5 Amp., 50/60HZ.
- 3Temp Range 90 - 135F.

#### Counter-Top Cabinets Medium

Model# SWC 36-G: Glass Door  
Model# SWC 36: Stainless Steel Door

- Compartment Size: 8.63 cubic ft.
- 26"W x 23"D x 25"H.
- Overall Size: 30"W x 26.5"D x 36"H.
- Electrical: 120V, 7.5 Amp., 50/60HZ.
- EI2 adjustable shelves.
- 35KW/HR, 1195 BTU/HR.

#### Counter-Top Cabinets Small

Model# SWC24-G: Glass Door  
Model# SWC24: Stainless Steel Door

- 26"W x 23"D x 15.25"H.
- Overall Size: 30"W x 26.5"D x 24.5"H.
- Electrical: 7.5 Amp., 50/60HZ, 120V.
- 1 Adjustable shelf.
- 30KW/HR, 1024 BTU/HR.

## Specialty Products

### Warming Cabinets



SWC72-G



SWC60-G  
Shown on optional dolly 6.75"H

#### Full Size Cabinets - Single Door

Model# SWC72-G: Glass Doors

Model# SWC72: Stainless Steel Doors

- Compartment Size: 21.0 cubic ft.
- 26"W x 23"D x 61"H.
- Overall Size: 30"W x 26.5"D x 74.5"H.
- Electrical: 120V, 7.5 Amp., 50/60HZ.
- 2 adjustable shelves, 2 fixed shelves.

Model# SWC60-G: Glass Doors

Model# SWC60: Stainless Steel Doors

- Compartment Size: 13.05 cubic ft.
- 26"W x 17"D x 51"H.
- Overall Size: 30"W x 20.5"D x 64.5"H.
- Electrical: 120V, 7.5 Amp., 50/60HZ.
- 3 adjustable shelves.

#### Full Size Cabinets Double Compartment

Model# DWC24-G: Glass Doors

Model# DWC24: Stainless Steel Doors

- Compartment Size: 17.2 cubic ft.
- Upper Chamber: 26"W x 23"D x 15.25"H.
- Lower Chamber: 26"W x 23"D x 34.5"H.
- Overall Size: 30"W x 26.5"D x 74.5"H.
- Electrical: 120V, 12 Amp., 50/60HZ.
- 3 Adjustable Shelves.
- Accuracy +/- 1 Degrees F.

Model# DW60-G: Glass Doors

Model# DW60: Stainless Steel Doors

- Compartment Size: 9.73 cubic ft.
- Upper Chamber: 26"W x 17"D x 13.5"H.
- Lower Chamber: 26"W x 17"D x 24.5"H.
- Electrical: 120V, 10 Amp., 50/60HZ.
- 3 Adjustable Shelves.



DWC60-G



DWC24

## Specialty Products

### Open Wire Catheter Storage



CATCOMB2CH



CATCOMB3CH

#### Open Shelf/Hook Catheter Carts

Complete with 40-hook rack, 2 shelves 60"W (bottom with plastic shelf cover), 3 shelves 24"W, 4 x 5" swivel casters with donut bumpers, two braking.

Model #CATCOMB2CH:  
Open unit 18"D x 60"W x 79"H overall.

Model #CATCOMB3CH:  
Same as above but with end and back closures of 3" x 3" wire mesh and 7 shelf bins at top.

Model # CRK40:  
Unit with 40 catheter hooks only 18"W x 36"L x 69"H overall.

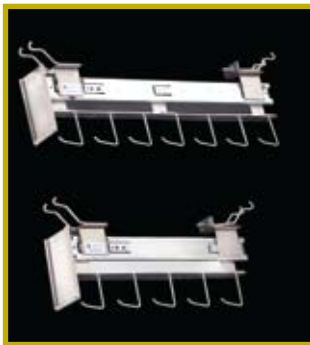

USC24 & USC18

#### Stainless Steel Catheter Slides

Mount beneath any wire shelf, card holder included, each hook holds up to 15 packages

Model #USC18: 18"D with 5 hooks

Model #USC24: 24"D with 7 hooks

#### Hanging Catheter Cart with Pull-Out Slides

- Wire carts with stainless steel pull-out catheter slides.
- Top and bottom wire shelf. 5" swivel casters & donut bumpers, 4-63" posts.
- Also available in standard 48", 60" or 72" lengths.
- Add suffix "E" for end and back closures of 3" x 3" wire mesh.

Model #HC1836CH:  
18 x 36 x 69 with 45 catheter hooks total (9 slides/5 hooks)

Model #HC2436CH:  
24 x 36 x 69 with 63 catheter hooks total (9 slides/7 hooks)



HC2436CH



CATH-15



CATH-15V

#### Nylon Catheter Holders

- 210 Denier nylon with clear vinyl front.
- Available in a wide variety of sizes and can easily be customized.
- Attach to wall or side of cart.

Model #CATH-8V: 8 pockets.  
Model #CATH-15V: 15 pockets.  
Model #CATH-20V: 20 pockets.  
Also available with nylon front. Delete "V" from model #.

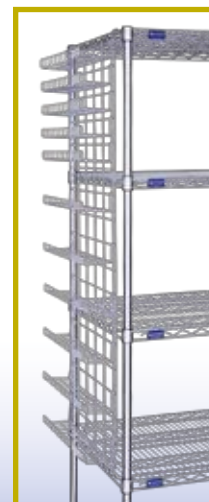

CAT-15CH

#### Wire Catheter Rack

- Can be attached to end of cart or modified for wall installation.
- Holds foley catheters.
- Frame 18"W x 52"H.
- Hanging basket 18.5"W x 2.5"H.

Model #CAT-15CH: 15 levels.



## Specialty Products

### Enclosed Catheter Storage

#### Enclosed Catheter Carts

We have a complete line of LogiCell® enclosed catheter carts and cabinetry. Below is a sampling of our products. For more information please refer to the LogiCell catalog and/or logiquip.com and click on "LogiCell".

#### Standard LogiCell® Features

- Constructed in 20-gauge textured epoxy coated steel with Frosty White finish.
- Cell system of plastic side panels accommodates a range of accessories (22 -usable cell per column).
- Standard Tambour door with cassette design.
- Double carts available with hinged glass doors of durable aluminum with hospital-grade safety glass. Add suffix -HG.
- Tubular handle on both ends. Wrap-around bumper. 5" swivel casters, two with brakes. Caster upgrade available.
- Tall Double Cart Dimensions: 40"W x 28"D x 80"H. 3/4 Double Cart Dimensions: 40"W x 28"D x 63.75"H.
- Tall Triple Cart Dimensions: 57"W x 28"D x 80"H.



**Model #2652CAT1HG**  
Cart with 7 catheter slides. Shown with "HG" glass doors



**Model #2652CAT5**  
Short/Long Cath Cart with 9 catheter slides, top shelf with 2 dividers



**Model #2653CAT2**  
Cart with 14 catheter slides and mix of shelves/baskets/tubs

DESCRIPTION	MODEL#
Double Catheter Cart with 7 slides..	2652CAT1
Double Catheter Cart with 7 slides and top shelf with 5 dividers.	2652CAT2
Double Catheter Box Cart with easy-tilt cath box holder. Top shelf with 5 dividers.	2652CAT3
Double Guide Wire/Balloon Cart. 5 adjustable shelves with each 4 dividers.	2652CAT4
Double Long/Short Catheter Cart with 9 catheter slides, two shelves each with two dividers.	2652CAT5
Double Cart with 6 cath slides, 2 shelves each with 2 dividers. 2 x 3", 2 x 5" and 1 x 8"H baskets and 1 x 5" tub each with 2 long and 2 short dividers.	2652CAT6
Double Cart with 3 cath slides and 5 shelves each with 2 dividers.	2652CAT7
Triple Catheter Cart with 9 catheter slides.	2653CAT1
Triple Catheter Cart with 14 catheter slides, 2 shelves 36"W each with 4 dividers, 2 shelves 16"W each with 4 dividers, 2 x 3", 1 x 5" and 1 x 8"H baskets. 1 x 3" and 1 x 5" tubs. All baskets/tubs have 2 long and 2 short dividers.	2653CAT2

## Specialty Products

### Cylinder Transports



CYL01



CYL02



CYL06

#### Cylinder Carts Available in a Variety of Capacities:

- Designed to transport D, E and "Grab-n-Go" size cylinders.
- Heavy duty construction with chip proof chrome-plated steel.
- Easy-to-slide-in cylinder slots.
- Accessory and mounting hook.
- Two casters and two support legs or four-wheel design.
- Solid axle.
- Floor protecting tips and ergonomic rubber handle.

Model #CYL-01: Single cylinder carrier

Model #CYL-01WB: Single cylinder carrier with four wheels.

Model #CYL-02: Double cylinder carrier

Model #CYL-04: Four cylinder carrier

Model #CYL-06: Six cylinder carrier

Model #CYL-12: Twelve cylinder carrier

#### Tall Cylinder Carriers

Equipped with back trolley, these carts are designed to safely carry one or two heavy tall cylinders with minimal effort.

- Back trolley equipped with the sure-lock system.
- Two large (10") front ball bearing wheels.
- Two 3" swivel casters on the back trolley.
- Safety chain encased in a polymer tubing.
- Baked-on aluminized coating with solid steel fabrication.
- Carry cylinders of 35" tall and up with a diameter of up to 10".

Model #CYL330: Single Carrier  
20"W (32"W unfolded) x 42"L x 44"H

Model #CYL340: Double Carrier  
(side by side) 20"W (32"W unfolded) x 42"L x 44"H

Model #CYL340-2: Double Carrier  
(front to back) 34"W (42"W unfolded) x 42"L x 44"H



CYL340



CYL12

#### Cylinder Cart

- Size: 17 x 26 x 34
- Constructed for easy and safe transport of cylinder type "D" and "E" for laboratories and productions usage.
- Capacity of 12 cylinders.
- PVC dipped rack quietly holds cylinder in place.
- 4 donut bumpers to protect walls and doors.
- 4-5" (127mm) swivel casters.

Model #CYL12

## Specialty Products

### Security Units and Carts

#### Security Units and Carts

- Unique design provides rugged and economical security for valuable items.
- Lockable handle.
- Open wire construction 2" x 2".
- Casters may be added to a security unit in order to provide a mobile unit.
- For mobile heavy-duty transport applications, a Dolly Base and 6" Casters are available.
- When determining the desired number of shelves, include one top and one bottom shelf. Example: SEC484FCH has four shelves. Three are usable for storage and the fourth is the top of the unit.
- Mini Carts also available.
- All Carts and Units shipped fully assembled.

#### Stationary

D x W x H	WT.	3 SHELVES	WT.	4 SHELVES	WT.	5 SHELVES
(inches)	(lbs.)	Model #	(lbs.)	Model #	(lbs.)	Model #
24 x 36 x 63	216	SEC363FCH	228	SEC364FCH	244	SEC365FCH
24 x 48 x 63	262	SEC483FCH	262	SEC484FCH	294	SEC485FCH
24 x 60 x 63	296	SEC603FCH	296	SEC604FCH	336	SEC605FCH



SEC604FCH



MSEC484FCH Mobile Unit

**Mobile** with 5" swivel casters, two with brakes.

D x W x H	WT.	3 SHELVES	WT.	4 SHELVES	WT.	5 SHELVES
(inches)	(lbs.)	Model #	(lbs.)	Model #	(lbs.)	Model #
24 x 36 x 69	284	MSEC363FCH	298	MSEC364FCH	314	MSEC365FCH
24 x 48 x 69	339	MSEC483FCH	355	MSEC484FCH	371	MSEC485FCH
24 x 60 x 69	387	MSEC603FCH	407	MSEC604FCH	427	MSEC605FCH



MDSEC364FCH Mobile Heavy-Duty Unit

**Mobile Heavy-Duty (Dolly Base)** 6" ergo casters, two fixed, two swivel (other configurations available).

D x W x H	WT.	3 SHELVES	WT.	4 SHELVES	WT.	5 SHELVES
(inches)	(lbs.)	Model #	(lbs.)	Model #	(lbs.)	Model #
24 x 36 x 71	284	MDSEC363FCH	298	MDSEC364FCH	314	MDSEC365FCH
24 x 48 x 71	339	MDSEC483FCH	355	MDSEC484FCH	371	MDSEC485FCH
24 x 60 x 71	387	MDSEC603FCH	407	MDSEC604FCH	427	MDSEC605FCH



Mini Unit Model

**Mini Carts Mobile** with 5" swivel casters, two with brakes and donut bumpers.

D x W x H	WT.	3 SHELVES	WT.	4 SHELVES
(inches)	(lbs.)	Model #	(lbs.)	Model #
18 x 36 x 40	66	MB18363CH	75	MB18364CH



# Linen

## Hampers



HS50

### Step-On Covered Single Hamper System

Complete System for Identification, Containment and Collection.

- Chrome plated steel.
- Step-on opening feature.
- 2" casters provide complete mobility.
- Bottom rack to support heavy loads.
- Storage rack for extra bags.

Model #HS50

### Linen Bags

Size 30" x 40".

Custom sizes available.

Model #BAGS: 210 Denier with cord and lock.

Model #BAGS-HD: 400 Denier (with leakproof coating) with cord and lock.

Model #BAGS-MH: Nylon mesh.

### Single Linen Hampers With and Without Lid:

- Basic chrome wire hamper stand.
- Often used as waste receptacle.
- 3" swivel casters. 12" x 19" x 38".

Model #CA20

- Same, but with top lid.

Model #CA21



CA21



CA24

### Double/Quad Linen Hampers:

- Permits separation of patient bed linens or sortation as desired.
- 1" tubular chrome construction.
- Wrap-around bumper to protect doorways and halls.
- 4 x 3" swivel casters.

Model #CA23- Overall size: 22" x 27" x 38"H.

All welded tubular double bag hamper with plastic cover.

Model #CA24: Same, but with foot pedal for hands free operation.

Model #CA29- Overall size: 27" x 43" x 38"H.

All welded tubular quad bag hamper with two plastic covers.

# Linen

## Apparel Carts

### Patient Apparel Carts

Designed for efficient distribution of patient apparel using a system of individual compartments for folded clothing and an area for hanging garments.

- 24"D x 60"W x 69"H.
- 12 individual compartments on 24" x 30" shelf with label holders.
- 30"W hanger bar. Bottom and top shelf 24"D x 60"W, 4 posts 63"H.
- 4- 5" swivel casters, two with brakes.
- Optional Dolly base with wraparound bumper available for mobile applications.

Model 2460-12CH

- 24"D x 60"W x 69"H.
- 35 individual compartments with label holders.
- Compartments separated by chrome divider rods 60"H (23 each).
- 60"W hanger bar. Bottom and top shelf 24"D x 60"W, 4 middle shelves 14"D x 60"W, 4 posts 63"H, 2 posts 59"H.
- 4- 5" swivel casters, two with brakes. Donut bumpers.
- Optional Dolly base with wraparound bumper available for mobile applications.

Model 2460-35CH

### Uniform / Coat Racks

Convenient means of storing - transporting lab coats, uniforms or any hanging garments.

- Includes 4 posts, 2 wire shelves, coat rod with brackets, donut bumpers and 5" swivel casters, two with brakes.

Model UR36CH: 18"D x 36"W x 79"H overall

Model UR48CH: 18"D x 48"W x 79"H overall

Model UR60CH: 18"D x 60"W x 79"H overall

### Coat Rods

Coat Rod can be added to any wire shelving unit. Specify depth of shelf when ordering.

Model 5036CH: 36"W

Model 5048CH: 48"W

Model 5060CH: 60"W



2460-12CH



2460-35CH

Hangers Sold Separately

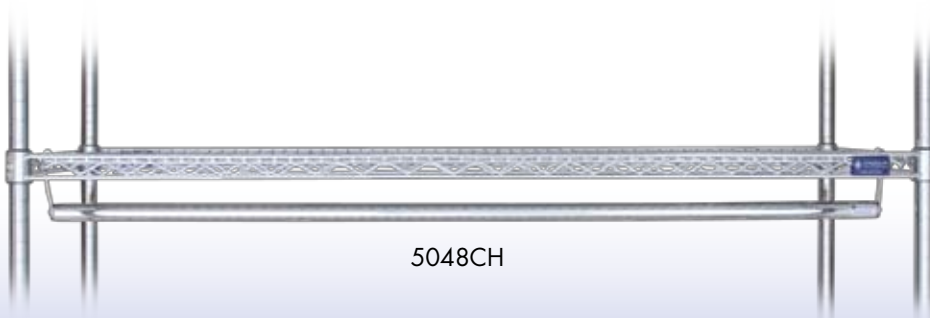

5048CH

### Chrome Hanger

Model CHCH



CHCH

# Linen

## Tub Carts



39-12-A

### Standard Utility Trucks:

- 3" all swivel threadguard casters. Other sizes available.
- Galvanized steel undercarriage with permanently attached body.
- Molded polyethylene with roll rim. 16 colors standard.

MODEL #	DEPTH (inches)	OVERALL HT (inches)	OUTSIDE L x W (inches)	BU	CUBIC FT
39-6	21	25	34 x 24	6	7
39-8	24	28.5	37 x 25.5	8	10
39-10	25	29	39.5 x 27.5	10	12
39-12	28	32	39.5 x 29.5	12	15
39-14	28	32	43 x 31.5	14	17
39-16	30	34	43 x 31.75	16	20
39-18	30	34	45.5 x 33.5	18	22
39-20	30	34	51 x 35.5	20	24

### Bulk/Specialty Trucks:

- Heavy-duty capacity.
- A, B and C caster configuration available unless otherwise specified.
- 5" rubber casters unless otherwise specified.

## MUST SPECIFY CASTER PATTERN (PG 75)



44P-16-A



50P-12-D



54P-20-B

MODEL #	CAPACITY OUTSIDE CU. FT.	CAPACITY OUTSIDE B.U.	CAPACITY OUTSIDE L x W x D (inches)	OVERALL HT (inches)		CASTERS (inches)
50P-12	13	11	35.5 x 24.5 x 28	34.5	A,B,C	5 Rubber
50P-14	19	16	39.5 x 28.5 x 32	38.5	A,B,C	5 Rubber
50P-16	21	18	43.5 x 28.5 x 32	38.5	A,B,C	5 Rubber
44P-12	11.5	10	38 x 29 x 32	34	A,B,C	5 Rubber
44P-14	13	11	44 x 31 x 25.5	32	A,B,C	5 Rubber
44P-16	17.5	14	49 x 31.5 x 27.5	34.5	A,B,C	5 Rubber
44P-18	20.5	17	54 x 29.5 x 27	34	A,B,C	5 Rubber
54P-16	18.5	16	42.5 x 28.5 x 28	34.5	A,B,C	5 Rubber
54P-18	22.5	18	53.5 x 28.5 x 27	33.5	A,B,C	5 Rubber
54P-26	33	27	53.5 x 28.75 x 39	45	D	5 Rubber
54P-40	40	32	76 x 40.5 x 25	32	D	5 Hrd Rbbr.
54P-40E	40	32	76 x 40.5 x 25	32	D	5 Hrd Rbbr.
54P-47	58	47	71 x 46 x 35.5	43	D	5 Rubber

Note: Canadian customers please refer to the product insert in your binder for your line of utility trucks



# Linen

## Elevated Carts + Casters + Backsaver Platform

### Elevated Carts:

- 3" all swivel threadguard caster in corner "A" pattern.
- Chrome steel undercarriage.

MODEL #	DEPTH (inches)	OVERALL HT (inches)	OUTSIDE L x W (inches)	BU	CUBIC FT
41C-2	12	29	34 x 25	2	2.25
41C-4	18	29	37 x 30	4	5.5
41C-6	21	29	39.5 x 32	6	7.5



41C-4

### MUST SPECIFY CASTER PATTERN (BELOW)



14BU

### Spring Platform "Back Saver":

- Self-leveling action eliminates fatigue of stooping and bending as work is loaded into truck.
- Platform automatically lowers load. As work is removed, platform raises load to EZ-REACH LEVEL.
- Available for any size or type of cart. Model # is determined by bushel size, i.e. 6 bushel cart, platform model# is 6-BUSP.

### Caster Patterns:

- Casters may be applied in one of four ways.
- The letter in the field applied to which caster configuration is available.
- Pattern A: Corner pattern. Swivel at four corners.
- Pattern B: Corner pattern. Swivel at one end, fixed at other.
- Pattern C: Diamond pattern. Swivel at ends, fixed at sides. Not recommended for 70, 80 or 90 series.
- Pattern D: Six casters. Swivel at four corners, fixed at middle.

### Drop-on and Hinged Lids:

- Drop-on lids are available for 6 to 20 bushel sizes; hinged lids are available for 6 to 12 bushel sizes. Model # is determined by bushel size. A 6-bushel cart drop-on lid model # is 6-BUDL. A 6-bushel cart hinged lid model # is 6-BUHL.

## CASTER PATTERNS

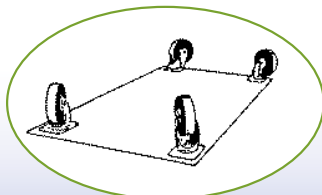

Pattern A  
4 Swivel

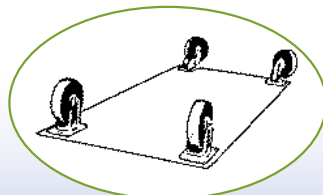

Pattern B  
2 Rigid, 2 Swivel

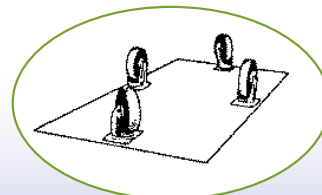

Pattern C  
4 Swivel

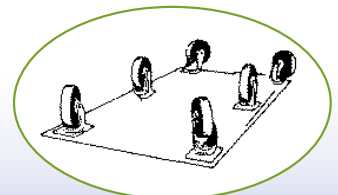

Pattern D  
2 Rigid, 2 Swivel

# Linen

## Wire Exchange and Par-Level Linen Carts

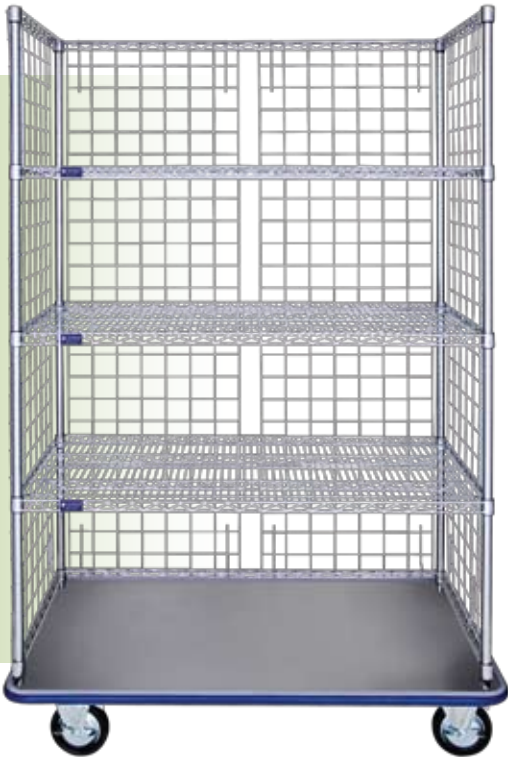

LC244-6SCH

### Enclosed 3-Sided Linen Exchange Carts

Excellent for in-house linen exchange systems.

- Heavy-duty dolly base with non-marking wrap-around bumper.
- Three wire shelves.
- Open carts have fourth wire shelf above dolly. Solid carts have solid stainless steel insert.
- Enclosure panels on sides and back.
- Three-sided frame at top allows top shelf down to be 10" to keep linen enclosed.
- 4 Posts 63" high.
- 4 x plate casters, all swivel, two braking, one with directional lock. Choose from 5" or 6" ergonomic.
- Overall height: 70".

Many other sizes and configuration available to suit your needs with no "Custom Upcharge". Refer to our wire shelving section for further information on building your custom cart.

MODEL #	DESCRIPTION	D x W x H (inches)
LC244-6SCH	Enclosed Linen Cart with Solid Stainless Steel Dolly, 4 shelves, 6" ergo casters	24 x 48 x 70
LC244-5SCH	Enclosed Linen Cart with Solid Stainless Steel Dolly, 4 shelves, 5" casters	24 x 48 x 70
LC244-6OCH	Enclosed Linen Cart with Open Wire Dolly, 4 shelves, 6" ergo casters	24 x 48 x 70
LC244-5OCH	Enclosed Linen Cart with Open Wire Dolly, 4 shelves, 5" casters	24 x 48 x 70
LC246-6SCH	Enclosed Linen Cart with Solid Stainless Steel Dolly, 4 shelves, 6" ergo casters	24 x 60 x 70

### Medium Duty Par-Level Linen Carts

These carts are an economical alternative for linen carts on a top-up system.

Model #ME436CH-CL - 24 x 36 x 60"H

Model #ME456CH-CL - 24 x 48 x 60"H

Model #ME466CH-CL - 24 x 60 x 60"H

Model #ME476CH-CL - 24 x 72 x 60"H

Comes complete with four posts 63", four wire shelves, solid plastic shelf cover on bottom shelf, flat-face full-length label holders all shelves, enclosure panels of 3" x 3" wire mesh. Four 5" poly swivel casters (two with brakes) and donut bumpers.



ME456CH-CL

## Tubular Style Convertible and Exchange Linen Carts

### Off-Site Linen Carts, Fixed and Drop Shelf Styles

These heavy duty carts have proven themselves through many years of durability in demanding over-the-road service. They come in two styles, convertible or fixed shelves. They are fabricated from 1-1/4" steel tubing and 3/8" wire rods all welded to form rigid frame to which the wire shelves are attached. Casters are 6" ergonomic neoprene.

### LN Series Drop Shelf

In the shelf-flat position the cart is a clean linen transporter. Empty the shelves, drop and lock then vertically to form bin to hold up to 15 bags of soiled linen. At the laundry just open the rear doors and the bags tumble to the floor, no lifting, straining or pulling.

### WR Series Fixed Shelf

This is an extra rigid cart since the back is fully enclosed with welded rods and tubes. Soiled linen bags set on shelves and are pulled off at the laundry. Front doors are optional.



LNF-60



WRW-60

MODEL #	HEIGHT (inches)	DIMENSIONS (inches)	WIRE SHELVES	FLAT SHELVES
LNW-60	65	24 x 60	2 drop, 1 fixed	—
LNF-60	65	24 x 60	2 drop	1 fixed
LNW-48	65	24 x 48	2 drop, 1 fixed	—
LNF-48	65	24 x 48	2 drop	1 fixed
WRW-60	71	24 x 60	3 fixed	—
WRF-60	71	24 x 60	2 fixed	1 fixed
WRW-48	71	24 x 48	3 fixed	—
WRF-48	71	24 x 48	2 fixed	1 fixed



CTU60

### Tubular Style Linen Exchange Carts:

- Shelves are easy to adjust by lifting off the end rungs and repositioning.
- Large cart serves up to 40 beds daily, small cart 30 beds.
- Heavy duty, cross bolstered, nickel-chrome steel dolly with stainless steel insert shelf to prevent contamination of supplies during transport. Wrap around bumper.
- 4 wire shelves.
- Casters are 6" poly. All swivel, 2 braking.  
Add suffix "BFP" for 1 swivel, 2 swivel w/ brake, and 1 directional locking.  
Add suffix "R" for 2 fixed, 2 swivel.  
Add suffix "FP" for 1 directional locking.
- Back screen of 3" x 3" wire mesh. Cross rungs enclose ends.

Model #CTU60 - 26" x 63" x 68"H

Model #CTU48 - 26" x 51" x 68"H



# Linen

## Poly Bulk/Convertible Linen Trucks



72P



72P w/ flap



90P

### Bulk Linen Carts- Poly:

- Molded polyethylene bodies, powder-coated, full-perimeter steel bases, and industrial grade casters.
- 16 colors are standard, custom colors are optional.

MODEL #	DEPTH (inches)	OVERALL HEIGHT (inches)	OUTSIDE L x W (inches)	BU	CUBIC FT
64P	41	48.25	60 x 42	48	60
70P	47	54.25	48 x 28.25	29	36
72P	59	66.25	48 x 28.25	38	48
73P	64	72	41 x 28.25	34	42
74P	51	59	41 x 28.25	26	32
75P	60	67.25	38 x 28.25	30	37
76P	68	76	42 x 28.25	37	46
77P	51	59	41 x 30	27	33
78P	56	65	52.25 x 43.25	56	70
79P	56	65	53.25 x 37	49	61

## AVAILABLE IN CASTER PATTERNS A & B (REFERENCE PG 75)

### Convertible Shelf Carts- Poly:

- Movable shelves permit the carts to serve as bulk trucks (for picking up soiled linens) or as delivery trucks (for carrying finished, folded goods).
- Molded polyethylene bodies, powder-coated, full-perimeter steel bases.
- Shelves optional, available in chrome wire or solid poly.
- 16 colors are standard, custom colors are optional.

MODEL #	DESCRIPTION	DIMENSIONS L x W (inches)	OVERALL D x H (inches)	BU	CUBIC FT
81P	Open Top, Wire Shelves	47.25 x 26	61.25 x 69	34	42
84P	Open Top, Wire Shelves	54.25 x 27.25	54 x 62	37	45
85P	Open Top, Wire Shelves	59.25 x 27.25	54 x 64.25	40	49
86P	Open Top, Wire Shelves	55.25 x 26	63.25 x 72.25	42	52
87P	Open Top, Wire Shelves	60 x 22	60 x 68	37	45
88P	Open Top, Wire Shelves	48 x 22	60 x 68	30	37
90P	Same, Wire or Poly Shelves	48 x 28.25	54 x 62	32	38
91P	Open Top, Wire Shelves	48 x 28.25	60 x 68	38	44
92P	Open Top, Wire Shelves	48 x 28.25	60 x 68	38	44
95P	Open Top, Wire Shelves	60 x 28.25	60 x 60	40	49

\* Note: 90PL Same as 90P but with closed top.

\* Note: On 91 series you can get a 3rd wire shelf but remains fixed. The 92 series can have 2 shelves only but is convertible.

## Aluminum Cart

### Specifications:

- Carts are all-welded aluminum construction with reinforced shelves.
- Casters are top quality 6" neoprene, 2 fixed and two swivel.
- Bumper: Corner bumpers on open carts. Wrap-around on closed carts.
- Anodized finish.



AG160

## Aluminum Bulk/Convertible Linen Carts

### Open Carts- Fixed Shelf:

- Two fixed shelves plus base shelf.

MODEL #AG137: 38.5"L x 23.5"W x 70"H overall. 34.5" x 20.75" inside.

MODEL #AG149: 50.5"L x 23.5"W x 70"H overall. 34.5" x 20.75" inside.

MODEL #AG160: 61.5"L x 23.5"W x 70"H overall. 57.5" x 20.75" inside.



AG360

### Open Carts- Convertible Shelf:

- Base shelf plus two convertible shelves.

MODEL #AG337: 38.5"L x 23.5"W x 70"H overall. 34.5" x 20.75" inside.

MODEL #AG349: 50.5"L x 23.5"W x 70"H overall. 34.5" x 20.75" inside.

MODEL #AG360: 61.5"L x 23.5"W x 70"H overall. 57.5" x 20.75" inside.

### Enclosed Carts- Fixed Shelf:

- Base shelf plus two fixed shelves. Fully welded construction.
- Doors: Full length aluminum lock wells enclosing two point locking mechanism. Full length S/S piano hinge. Opened doors secure to cart ends, with magnetic catches, and do not extend past cart back.
- Recessed handles of 1" x 3/8" obround bar are welded to each end.

MODEL #AG736: 37.5"L x 23.5"W x 69"H overall. 33.5" x 20.75" inside.

MODEL #AG745: 46.5"L x 23.5"W x 69"H overall. 42.5" x 20.75" inside.



AG760BF



AG860

### Enclosed Carts- Semi-Enclosed:

- Base shelf plus two fixed shelves. Fully welded construction.
- 200 denier nylon front flap with velcro side and top strips.
- Recessed handles of 1" x 3/8" obround bar are welded to each end.

MODEL #AG836: 37.5"L x 23.5"W x 69"H overall. 33.5" x 20.75" inside.

MODEL #AG845: 46.5"L x 23.5"W x 69"H overall. 42.5" x 20.75" inside.

MODEL #AG860: 62"L x 23.5"W x 69"H overall. 58" x 22" inside.

## Stores

### Painted Metal Boltless Shelving



Open Unit

#### Boltless Shelving Units: Open and Closed

These units work well in medical records, in some stores applications or when an affordable solid unit is all that is required.

- U-shaped extra ribbed front and back edges for extra capacity.
- Double angle front and back 14 gauge posts.
- Clip-type shelving easy to install.
- Durable dove grey alkyd baked enamel.

#### Components for a Basic Open-Type Unit

- Starter unit consists of 4 angled posts, 2 pairs of side braces, 1 pair of back braces.
- Add-on unit consists of 4 angled posts, 1 pair of side braces, 1 pair of back braces.
- Determine number of shelves required.

#### Components for a Basic Closed-Type Unit

- Starter unit consists of 4 angled posts, 2 sets of side panels, 1 set of back panels (allow for 4" overlap).
- Add-on unit consists of 4 angled posts, 1 set of side panels, 1 set of back panels (allow for 4" overlap).
- Determine number of shelves required  
Available Heights: 76", 88", 100", 112", 124", 148"
- Shelf Sizes: 12"x 36", 12" x 48", 15"x 36" x 15"x 48", 18"x 36", 18"x 42", 18"x 48", 24" x 36" x 24" x 48"

#### Available Accessories

Footplates for carpet or tiled floor, baseplates for strength and appearance, angle reinforcements for heavy load, 6", 8", 10", 12" and 18"H dividers for most units, shelf bin fronts, label holders, drawers and double-swing doors.

Contact customer service with your requirements or your representative can help design a system according to your needs.

Painted metal shelves not sold in U.S.



Closed Unit



## Stores

### Pallet Racking

#### Racking with Wire Mesh Decking

Designed for heavy load storage in Bulk Stores or off-site warehouses.

- Featuring pre-engineered construction offering great strength and load bearing capacity with easy assembly and adjustability.
- Step-style beams are mig-welded featuring wrap around one-piece connector plate.
- Integral safety catch snaps and locks into place as beams are properly seated.
- Upright frames are mig-welded structures featuring channel, K-bracing. Punched every 2" for best vertical adjustability.
- Large 4-1/2" footplates for anchoring upright to floor.

Although it is best to have pallets off floor, full pallets of I.V. solutions can often be pallet-jacked into position on the floor below racking.



#### Wire Decking

Recommended for medical supplies. These heavy duty mesh panels feature 3" openings in 1/4" wire. Each grid is supported by two deck supports and should be tied in place. They are excellent for hospitals in that they do not collect dust, have superb light penetration and permit fire sprinklers to work more effectively. Finished in zinc plating.

#### Ordering Information

To begin you will require 2 frames plus quantity of beams depending on number of levels. Additional beams are then strung from second frame to third frame and so on to form a row.

Please contact your sales representative for further assistance.

## Stores

### Flow Rack/IV Rack



#### Supply/Solution Racks

Whether for IVs, supplies or linen flow racking ensures that supplies are properly rotated. Whether on or off-site, the concept fits perfectly with a hospital's stock picking requirements.

- Provides first-in, first-out usage, easy restocking from rear (picking and restocking may be handled at the same time).
- The system provides an ideal method of organizing products according to usage, volume and category.
- It works by loading product at the back, either by case or in containers, onto rolled track runways.
- As product is removed from the front the next case or container flows into picking position.
- Racks are sold in bays, each bay is 84"H x 60"W x 60"D. Each bay is complete with four or five levels, uprights, frames, tracks and guides. Begin with a single bay and add-on as necessary.
- For IV solutions, the capacity of each 4-level bay is 80 cases of standard boxes. An additional level may be added but it would be a 72" from floor. If you choose to remove the bags from their cases and display in our plastic shelf boxes, then up to seven level capacity is available.



MODEL #	DESCRIPTION	D x W x H (inches)
FR60604	Single bay c/w 4 levels	60 x 60 x 96
FR60604A	Add on bay, 4 level	60 x 60 x 96
FR60605	Single bay c/w 5 levels	60 x 60 x 96
FR60605A	Add on bay, 5 levels	60 x 60 x 96
FR60F	Extra shelf frame c/w	60 x 60

#### 10 tracks and 4 guides

MODEL #	DESCRIPTION	DIMENSIONS (inches)
FR60U	Extra upright	60 x 96
FR60T	Extra track	60
FR60G	Extra guide	60
FR60B	Extra brace	60



# Stores

## Attached Lid Containers

These well-designed, strong distribution containers are ideal for transporting supplies from off-site or within the facility. Standards dictate that cardboard cannot be in a clean utility room making these containers a necessity.

- Attached lids snap securely to protect contents from dust or damage.
- Containers stack and nest for space optimization
- Padlock tie at both ends to accommodate security ties.
- Some models have a variety of colours. Standard colour: Grey.
- Molded-in handles for easy lifting and carrying.



9-452



9-462



He's Baaaack!!!

MODEL #	L x W x H (inches), OD	L x W (inches) , Bottom Interior	QUANTITY	COLORS	NOTES
9-442	21.5 x 15 x 9	18.43 x 13.25	6	Grey, Red, Blue, Green	popular for IV solutions
9-452	21.5 x 15 x 12.5	18.43 x 13.25	6	Grey, Red, Blue, Green	most popular
9-520	27 x 17 x 12.5	23.5 x 14	6	Grey, Red, Green	2nd most popular
9-462	21.5 x 15 x 17	18.43 x 13.25	3	Grey Only	
9-592	24 x 19.5 x 12.5	20.5 x 16.5	1	Grey Only	
9-570	28 x 21 x 15.5	25 x 18	1	Grey Only	
9-700	34 x 24 x 20	30 x 19.5	1	Grey Only	

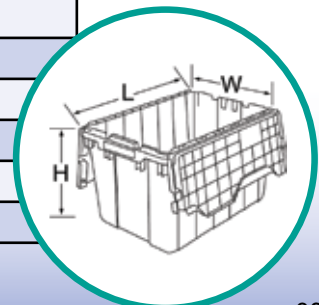



# Stores

## Dividable Containers



### Dividable Containers

- Injection molded from high-density polyethylene which resists most solvents and chemicals. Ribbed design gives added strength. Blue, red or grey.
- Dividers allow subdivision of the containers down to a 1" square compartment size.

MODEL #	L x W x H (inches), OD	CAP. CU. FT.	WT. CAP.	CTN. QTY.
33105	10.87 x 8.25 x 5	0.16	25	20
33164	16.5 x 10.88 x 4	0.29	20	12
33166	16.5 x 10.87 x 6	0.44	35	8
33168	16.5 x 10.87 x 8	0.59	40	6
33220	22.38 x 17.38 x 10	1.66	50	2
33224	22.38 x 17.38 x 4	0.611	30	6
33226	22.38 x 17.38 x 6	0.964	40	4
33228	22.37 x 17.37 x 8	1.3	50	3

MODEL #	DESCRIPTION	CTN
	Cover, Divider, Holder	quantity
33101	Clear Plastic Cover for 33105	10
33161	Clear Plastic Cover for 33166 and 33168	4
33221	Clear Plastic Cover for 22338	3
42105	Long Divider for 33105 (5 max)	6
41105	Short Divider for 33105 (7 max)	6
42166	Long Divider for 33166 (7 max)	6
41166	Short Divider for 33166 (11 max)	6
42168	Long Divider for 33168 (7 max)	6
41168	Short Divider for 33168 (11 max)	6
42228	Long Divider for 33228 (11 max)	6
41228	Short Divider for 33228 (15 max)	6
35010	Label Holder	6



### Nest and Stack Totes

- Optional lids snap securely onto the tote boxes.
- The clear plastic label holder accepts a 3" x 5" label.

MODEL #	L x W x D (inches), Outside	A - INSIDE (inches)	B - INSIDE (inches)	C - INSIDE (inches)	D - INSIDE (inches)	E - INSIDE (inches)	CAPACITY Cu. Ft.	CTN. Qty.	MODEL # Lid
35-180	18 x 11 x 6	10	16	15-1/4	9-3/8	5-7/8	0.5	6	35-181
35-190	19-1/2 x 15-1/2 x 10	14-1/2	17	16	13-1/4	9-7/8	1.2	6	35-191
35-200	19-1/2 x 13-1/2 x 8	12-3/8	17-1/8	16-3/8	11-1/2	7-7/8	0.8	6	35-201
35-230	23-1/2 x 19-1/2 x 13	18-1/8	20-7/8	19-1/2	16-7/8	12-7/8	2.6	3	35-231
35-240	23-1/2 x 15-1/2 x 12	14-1/4	20-7/8	19-5/8	13	11-7/8	1.7	3	35-241
35-300	29-1/2 x 19-1/2 x 15	18-1/4	26-5/8	25-1/8	16-5/8	14-7/8	3.7	3	35-301

Model # 35-010 Label Holder - Fits All Sizes . One color per carton. Specify red, blue, or grey.

## Stores

### Shelf Bins

MODEL #	D x W x H (inches), OD	CARTON (quantity)	COLORS	DIVIDER
SB110	11.62 x 2.75 x 4	24	Red, Yellow, Blue	N/A
SB120	11.62 x 4.12 x 4	24	Red, Yellow, Blue	SBD120
SB130	11.62 x 6.62 x 4	12	Red, Yellow, Blue	SBD130
SB150	11.62 x 8.37 x 4	12	Red, Yellow, Blue	SBD150
SB170	11.62 x 11.12 x 4	12	Red, Yellow, Blue	SBD170
SB128	17.87 x 4.12 x 4	12	Red, Yellow, Blue	SBD120
SB138	17.87 x 6.62 x 4	12	Red, Yellow, Blue	SBD130
SB158	17.87 x 8.37 x 4	12	Red, Yellow, Blue	SBD150
SB178	17.87 x 11.12 x 4	12	Red, Yellow, Blue	SBD170
SB124	23.62 x 4.12 x 4	12	Red, Yellow, Blue	SBD120
SB164	23.62 x 6.62 x 4	6	Red, Yellow, Blue	SBD130
SB184	23.62 x 8.37 x 4	6	Red, Yellow, Blue	SBD150
SB174	23.62 x 11.12 x 4	6	Red, Yellow, Blue	SBD170
SBD120	Dividers	24	Black	
SBD130	Dividers	24	Black	
SBD150	Dividers	24	Black	
SBD170	Dividers	24	Black	

Durable polypropylene shelf bins provide a neat appearance on a budget. Works with 12", 18" and 24" deep shelving. One-piece construction. Available in blue, yellow or red. Width-wise dividers available in packages of 12. Bin cups and extended label holders also available.  
NOTE: Must order in stated carton quantities.



SB174



SB138



SB110



SB348 bin w/ included divider

#### Extra Large Beige Shelf Bins

For use on 18", 21" or 24" deep wire shelving. Super durable co-polymer polypropylene construction. Stackable with reinforcing ribs to prevent spreading under heavy loads. Front and back finger grips for easy handling. One black cross-wise divider included per bin.

NOTE: Must order in carton quantities of 6.

Model #SB348: 8.25"W x 20.5"L x 7"H overall, 7.37" x 20"L x 6.5"H interior.

Divider #SBD348 Pkg. of 6 only.

Model #SB358: 11"W x 20.5"L x 7"H overall, 10.12" x 20"L x 6.5"H interior.

Divider #SBD358 Pkg. of 6 only.

## Stores

### Semi-Open Front Bins

MODEL #	L x W x H (inches)	CARTON (quantity)	COLORS	DIVIDER
B202	4 x 4 x 2	EA	Red, Yellow, Blue, Green	n/a
B203	6.5 x 4 x 2	EA	Red, Yellow, Blue, Green	n/a
B210	5.75 x 4.25 x 3	24	Red, Yellow, Blue	D210
B211	6.5 x 4 x 3	EA	Red, Yellow, Blue, Green	D211
B220	7.25 x 4.25 x 3	24	Red, Yellow, Blue	D220
B221	9.5 x 6 x 5	EA	Red, Yellow, Blue, Green	D221
B224	10.75 x 4.125 x 4	12	Red, Yellow, Blue	n/a
B230	10.75 x 5.5 x 5	12	Red, Yellow, Blue	D230
B234	14.75 x 5.5 x 5	12	Red, Yellow, Blue	n/a
B235	10.75 x 11 x 5	6	Red, Yellow, Blue	D230
B239	10.75 x 8.25 x 7	6	Red, Yellow, Blue	D239
B240	14.75 x 8.25 x 7	12	Red, Yellow, Blue	D245
B242	14 x 8 x 6	EA	Red, Yellow, Blue, Green	D242
B244	14 x 8.5 x 8	EA	Red, Yellow, Blue, Green	D244
B246	14.5 x 19 x 6	EA	Red, Yellow, Blue, Green	D246
B250	14.75 x 16.5 x 7	6	Red, Yellow, Blue	D245
B270	20 x 12.5 x 6	3	Red, Yellow, Blue	D270
B275	20 x 12 x 8	EA	Red, Yellow, Blue, Green	D275
B280	20 x 12 x 12	EA	Red, Yellow, Blue, Green	D280
B290	20 x 18 x 12	EA	Red, Yellow, Blue, Green	D290
B295	28 x 18 x 12	EA	Red, Yellow, Blue, Green	n/a
B297	24.25 x 6 x 5.75	8	Blue	n/a
D210	Dividers	6	Black	
D211	Dividers	EA	Black	
D220	Dividers	6	Black	
D221	Dividers	EA	Black	
D230	Dividers	6	Black	
D239	Dividers	6	Black	
D245	Dividers	6	Black	
D242	Dividers	EA	Black	
D244	Dividers	EA	Black	
D246	Dividers	EA	Black	
D270	Dividers	6	Black	
D275	Dividers	EA	Black	
D280	Dividers	EA	Black	
D290	Dividers	EA	Black	



B280



B210



B239



B235



B221

B275

B211



## Terms and Conditions

### Acceptance

All orders subject to acceptance of Terms and Conditions of sale, regardless of the form in which submitted. All orders are quoted F.O.B. Galesburg, Michigan unless stated otherwise. Custom manufactured products may be subject to a deposit at the time of order.

### Order Confirmation

To avoid duplication of shipment, the word "CONFIRMATION" or "CONFIRMING" should appear on all documents which are sent to confirm orders placed by telephone, fax or any other way.

### Terms

Minimum order \$50.00. Terms are Net 30 days (subject to credit approval). An annual service charge of 24% will be assessed on past due accounts.

### Shipments

Shipments will be made F.O.B. shipping point and the buyer assumes responsibility for all damages in transit. Such damages must be declared at time of receipt, directly on the shipping documents, and claims must be filed immediately with the transport company. If after receipt of shipment, concealed damage is discovered, immediately notify the delivering carrier requesting an inspection. The inspection report should be used to support your claim against the carrier. Any claim for damage or shortage must be filed by you with the delivering carrier. Unless a preferred routing is specified at the time of order, shipment will be made the best way, transportation prepaid and added to invoice.

### Returned Goods Policy

1. All returns must be authorized.
2. Each request must include the following:
  - A. Customer name and address.
  - B. Invoice number
  - C. Invoice date
  - D. Customer P.O. number
  - E. Quantity, catalog number and description of item
  - F. Reason for return
3. Upon receipt of your request, a return authorization number will be issued and this must be clearly referenced with your return.
4. The return shipment must be coordinated with a customer service representative, who will advise the proper mode of transport for the return.
5. Returned goods may be subject to a minimum 20% handling charge based on state, condition of goods and reason for return.

### Returned Goods Policy

6. Returns will NOT be authorized for the following:
  - A. Items purchased on a "special order" basis (unless original vendor will accept the return).
  - B. Items that are custom manufactured.
  - C. Partial units of sale.
  - D. Items without original packaging materials.
7. **RETURNS MUST BE PREPAID AND WITHIN 10 DAYS OF ORIGINAL SHIPMENT.**

### Specifications

All dimensions and shipping weights are approximate. LogiQuip reserves the right to change specifications or substitute products of equal specifications without notice. The company also reserves the right to cease manufacturing or distribution of any product without notice. Manufacturer's specifications and prices are subject to change without notice.

### Freight Classification

Freight Class is product specific and may vary from CL70 to CL250.

### Installation

Installation of cabinets: Must be in compliance with all state and local code regulations and should be performed by experienced and qualified tradespeople. For best long term results and proper functioning of the cabinet doors and latches, the cabinets must be installed plumb and squarely true with adjoining cabinets. Compliance with all state and local regulations relative to anchoring cabinets should be confirmed by the appropriate hospital staff. Improper installation, or failure to comply with state and local regulations, may result in failure of the product and denial of potential warranty claims.

### Warranty Statement

LogiQuip equipment is warranted to be free from defective material and workmanship under normal use and service for a period of one year from date of shipment to customer. During this period, LogiQuip will repair or replace (at its option) without charge, F.O.B. plant of manufacture, the equipment or any part thereof which factory inspection discloses to be defective. Shipments of defective material for repair must be sent prepaid.



# Index

<b>A</b>		<b>E</b>	
Accessories, Wire Carts .....	28-37	Elevated Carts, Plastic .....	75
Aluminum Linen Carts .....	79	Enclosed Supply Carts .....	15, 57, 69
Aluminum Transport/Bin Carts .....	48	End/Back Ledges, Wire .....	30
Apparel Carts .....	73	End/Back Panels, Wire .....	30
<b>B</b>		Equipment Stands .....	61
Backsaver/Spring Platforms .....	75	Exchange Carts/IV .....	55
Basket/IV Carts .....	40-41	Exchange Carts/Linen .....	77
Basket/Mail Carts .....	64-65	Exchange Carts, Supply .....	54
Bins, Attached Lid Containers, Plastic .....	83	<b>F</b>	
Bins, Transport Carts, Plastic .....	83	Fluid Warming Cabinets .....	66
Bins, Dividable Container Bins, Plastic .....	84	Floor Track Storage System .....	38-39
Bins, Semi-Open Front Bins, Plastic .....	85-86	Flow Racking .....	82
Bins, Shelf Bins, Plastic .....	85	Foot Plate .....	33
Bins, Tilt Bins, Plastic .....	10	Frames, 3-sided .....	32
Bins, Wire Bins and Baskets, Par Wall .....	6, 10	<b>G</b>	
Bins, Wire .....	6, 10, 31	Gravity/Flow Rack .....	82
Blanket Warming Cabinets .....	66-67	<b>H</b>	
Bulk Carts, Laundry .....	74-79	Hampers, Linen .....	72
Bumpers, Donut .....	29	Handles, Push .....	32
<b>C</b>		High Density Storage System, Floor Track .....	38-39
Cabinets, Warming .....	66-67	High Density Storage System, Par Stor .....	11-16
Cabinets, Catheter, Mobile .....	69	<b>I</b>	
Cantilever Wall Shelving .....	47	Implant/Ortho Carts .....	14, 42-43
Carts- See Quick Reference Guide on opposite page		IV Carts .....	14-15, 40-41, 55
Cart Covers, Nylon .....	36	<b>L</b>	
Cart Covers, Plastic Disposable .....	37	Label Holders, Par Stor .....	16
Casters .....	29	Label Holders, Par Wall .....	7
Catheter Bags, Nylon .....	68	Label Holders, Wire .....	34
Catheter Carts, Wire .....	68	Label Tags, Colored .....	34
Catheter Cabinets, Enclosed, Mobile .....	69	Lens Carts .....	42-43
Catheter Racks .....	68	Linen Carts, Aluminum .....	79
Catheter Slides .....	68	Linen Carts, Exchange .....	76-79
Coat Racks and Rods .....	73	Linen Carts, Poly .....	78
Containers, Attached Lid .....	83	Linen Carts, Soiled .....	72, 74-75
Containers, Dividable .....	84	Linen Carts, Top Up .....	76
Convertible Carts, Linen .....	77	Linen Carts, Tubular Chrome .....	77
Corner Carts .....	44	Linen Carts, Wire .....	76
Covers, Cart .....	36-37	Linen Hampers .....	72
Cylinder Handling .....	70	Ledges, Wire .....	30
<b>D</b>		LogiCell Carts .....	57, 69
Decking, Wire .....	81	<b>M</b>	
Dialysis Transport Carts .....	49	Mail Carts .....	64
Distribution Carts .....	48-55	Mobile Wire Shelving, Open, 4-tier .....	20
Distribution Containers .....	83	Mobile Wire Shelving, Open, 5-tier .....	21
Dividable Containers .....	84	Mobile Wire Shelving, Enclosed, 4-tier .....	22
Dividers, Wire Shelf .....	35	Mobile Wire Shelving, Open, 5-tier .....	23
Dividers, Basket .....	40	<b>O</b>	
Dividers, Par Wall "Lean" .....	7	Ortho/Implant Carts .....	14-15, 42-43
Dividers, Par Stor "Lean" .....	16	Over-The-Road/Offsite Carts .....	48
Dividers, Rod and Tab .....	35	<b>P</b>	
Document Holder, Wire .....	31, 59	Pallet Racking .....	81
Dolly Base Wire Carts, Open 4-Tier .....	24	Par Cart System .....	14-15
Dolly Base Wire Carts, Open 5-Tier .....	25	Par Stor Storage System .....	11-16
Dolly Base Wire Carts, Enclosed 4-Tier .....	26	* Par Stor Standard and Wide Modules .....	13
Dolly Base Wire Carts, Enclosed 5-Tier .....	27	* Open/Preconfigured Par Carts .....	14
Dollies .....	29		
Donut Bumpers .....	29		
Drawer Carts .....	55		
Dunnage Racks .....	32		

- \* Enclosed Par Carts ..... 15
- \* Par Stor Baskets/Shelves/Frames ..... 16
- Par Wall Storage System ..... 3-10
- \* Wall-Mount Complete Systems ..... 4
- \* Freestanding Complete Systems ..... 5
- \* Par Wall Baskets and Shelves ..... 6
- \* Par Wall Dividers and Label Holders ..... 7
- \* Par Wall Frames and Mobile Kits ..... 8
- \* Par Wall Panel Mount Brackets for Frames ..... 9
- \* Par Wall Panels, Spikes and Bins ..... 10
- Patient Apparel Carts ..... 73
- Peel Pouch Storage ..... 13
- Pick Carts ..... 65
- Plastic Bins ..... 83-86
- Plastic Carts, Utility ..... 62-63
- Plastic Containers, Bins ..... 83-86
- Plastic Tub/Laundry Carts ..... 74-75, 78
- Plastic Wire Shelf Covers ..... 46
- Platforms ..... 28
- Posts ..... 28
- Post Clamps ..... 33
- Post Levels and Caps ..... 28

## R

- Racking, Flow ..... 82
- Racking, Hand-Load ..... 81
- Racking, Pallet ..... 81
- Racking, Solution ..... 82

## S

- Screens, End and Back ..... 30
- Security Units and Carts ..... 71
- Seismic Accessories, Par Wall ..... 8
- Seismic Accessories, Wire Shelving ..... 33
- Service Carts ..... 62-63
- Shelf Covers, Plastic ..... 46
- Shelving, Mobile Wire ..... 20-23
- Shelving, Solid ..... 80
- Shelving, Wall-Mount, Par Wall ..... 4, 10
- Shelving, Wire ..... 18-19
- Side/Back Ledges, Wire ..... 30
- Slanted Shelf Carts ..... 42-43
- Solution/IV Carts ..... 40-41, 55
- Spring Platform, "Backsaver" ..... 75
- S-Hooks ..... 33
- Stock Cart ..... 65
- Suture Carts ..... 42-43

## T

- Tilt Bins ..... 10
- Totes, Plastic ..... 83-84
- Track System ..... 38-39
- TSUN Storage System ..... 45
- Tub Carts, Plastic ..... 74-75
- Tubular Carts ..... 48-49, 54-55, 77

## U

- Uniform Racks ..... 73
- Utility Carts, Plastic ..... 62-63
- Utility Carts, Stainless ..... 60
- Utility Carts, Wire ..... 58-59, 64
- Utility Tables ..... 61

## W

- Wall-Mount Supply Storage, Cantilever ..... 47
- Wall-Mount Supply Storage, Par Wall ..... 4, 10
- Warming Cabinets ..... 66-67
- Wire Decking ..... 81
- Wire Shelves ..... 28
- Wire Shelving Static Units 4-tier ..... 18
- Wire Shelving Static Units 5-tier ..... 19

## CARTS

### Quick Reference Guide

- Basket Carts ..... 40-41
- Catheter Carts ..... 68-69
- Corner Carts ..... 44
- Covers, Nylon/Plastic ..... 36-37
- Cylinder Carts ..... 70
- Dialysis Jug Transport Carts ..... 49
- Dolly Base Wire Carts, Open 4-Tier ..... 24
- Dolly Base Wire Carts, Open 5-Tier ..... 25
- Dolly Base Wire Carts, Enclosed 4-Tier ..... 26
- Dolly Base Wire Carts, Enclosed 5-Tier ..... 27
- Drawer Carts ..... 55
- Exchange Carts/IV ..... 55
- Exchange Carts/Linen ..... 76-77
- Exchange Carts/Supply ..... 54
- Hamper Carts ..... 72
- IV Carts ..... 40-42, 55
- Linen Carts ..... 76-79
- LogiCell Carts ..... 57, 69
- Mail Carts ..... 64
- Offsite Warehouse/Linen Carts ..... 48
- Par Carts ..... 14-15
- Par Wall System, Mobile ..... 5
- Patient Apparel ..... 73
- Security Carts ..... 71
- Suture Carts ..... 42-43
- TSUN Storage Carts ..... 45
- Uniform Carts ..... 73
- Utility Carts, Wire, Stainless, Plastic ..... 58-65
- Wire Carts, Enclosed, 4-Tier ..... 22
- Wire Carts, Enclosed, 5-Tier ..... 23
- Wire Carts, Open, 4-Tier ..... 20
- Wire Carts, Open, 5-Tier ..... 21





Healthcare Storage Solutions

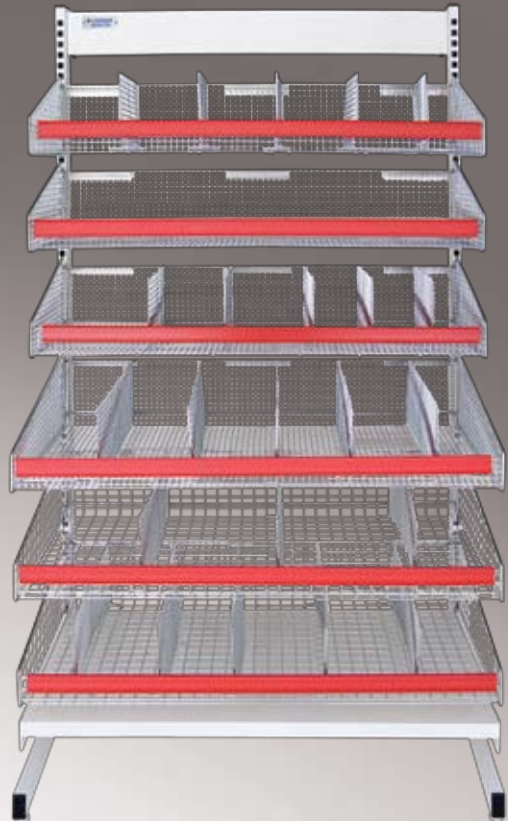
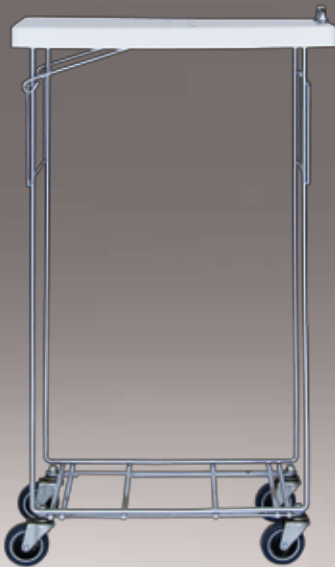

5466B Timberlea Blvd.

Mississauga, Ontario, Canada L4W 2T7

Tel: 1-800-551-0560 Fax: 888-625-0151

[www.acart.ca](http://www.acart.ca)

[info@acart.ca](mailto:info@acart.ca)