

WATER FILTER MWH-3 / UVH-3

INSTALLATION AND MAINTENANCE MANUAL

Welcome to RENWater!

Congratulations on choosing our state-of-the-art water filtration system to enhance the quality of water in your home. Our commitment is to provide you with a reliable and efficient solution for pure, refreshing water.

For additional support or inquiries, visit our website at renwater.com or contact us at sales@renwater.com

General direction for use

- Use only for filtration of water with pH from 6.5 to 9.5. In case of water with pH below or above the limits use only housings marked as pure polypropylene (PP).
- In case of filtration of drinking water, do not use with unsafe water or with water of unknown quality without adequate disinfection before or after the filter.
- Keep protected from light, install under direct light only models with opaque bowl.
- Keep protected from back-flows with a non-return valve.
- Keep protected from water hammer with an anti-water hammer device. In case of installation on systems powered by a pump and especially on those equipped with a pressure and flow controller, an additional expansion vessel must be installed upstream the filter to protect it from eventual repeated pressure peaks (figure C).
- Do not install near to electric appliances.

WARNING: Respect the working conditions, as shown in the sticker affixed to the product. If the sticker is tampered, damaged, not legible or missing, applicable working conditions are: maximum operating pressure 8 bar (10 bar for filters with metal/brass head), maximum operating temperature 45°C (80* for filters marked HOT); minimum operating temperature 4 °C. If pressure exceeds the working conditions, protect the product with a pressure reducer.

Installation guidelines

- Install the products in sheltered rooms and protected from freeze and excessive heat.
- Before the installation, check if the hydraulic system has been set-up according to the rules-of-the art in force.
Refer to figures:
A Mounting bracket top and front view lay-out.
B IN - OUT directions presentation in filter housings head caps.
C Installation.
D hardware parts list lay-out.
- * For products with pressure gauges: apply sealing tape on threads of the pressure gauges and then screw them, do not overtighten, onto 1/8" of the threaded connection at the top of the head; when the filter is set operational, if water is leaking, add sealing tape or screw tighter. For models with brass head, unscrew the caps at the top of the head and screw the pressure gauges according to the procedure indicated above.
- * For products with plugs (screws) for pressure gauges: screw the plugs (provided with o-rings) on tightly.
- * For products with drain kit: screw the plastic nipple with o-ring to the threaded connection for the drain at the bottom of the container, screw the ball valve onto the nipple, after having made sure there is a gasket, then screw the ball valve to the drain funnel or to the hose connector tube, after having made sure there is a gasket.
- * For products with drain plug: screw the plug on tightly.

Maintenance

- Periodically clean with cold water and a soft sponge. Replace the filter cup every 5 years at least.
 - Before opening: turn-off water mains and release the pressure by un-screwing the vent-valve on housing head. Then screw and tighten the vent-valve.
 - If not in use for a long time: remove the cartridge; when re-using apply a new cartridge.
 - Check the housing tightening, if water leaks between sump and head lubricate the o-ring or change with a new one.
- >t Remark: after the maintenance, let the water flow for at least 5 minutes before the use.

Replacement of the cartridge

Follow standards in force regarding waste disposal of used cartridges,

1. Before opening the filter housing turn-off the water mains.
2. Release the pressure from the product by un-screwing the vent-valve of the head. Then screw and tighten the vent-valve
3. Open the housing unscrewing the housing using a proper wrench.
4. Remove the used cartridge.
5. Wipe clean the filter housing with cold water and a soft sponge.

6. Open the new cartridge wrap and discard wrap.
 7. Put a new cartridge in the container.
 8. Tighten the housing bowl to housing's head using a proper wrench. Do not over-tighten.
 9. Turn-on the water mains.
 10. Slowly turn-on a water supply (tap) downstream the filter.
 11. Wait for air purge from the vent-valve, then screw and tighten the vent-valve.
- > Remark: let the water flow for at least 5 minutes before the use.

WARNING: at re-start after every maintenance operation and/or refill change, when the filter's bowl is unscrewed from head, change the o-ring with a new one and carefully lubricate before tightening the bowl to the head. Make sure that there are no water leaks from the product and especially control the tightening between the housing head and the housing bowl. Continue checking that the tightening is good and there is no water leakage for 48 hours following the installation and start-up. In case of leakage, open the housing, remove the o-ring from the bowl, place a new o-ring and apply lubricant, then re-tighten the bowl to head and repeat the leakage check as above.
Ask your vendor for original o-rings, lubricant and other spare parts.

FIGURE A:

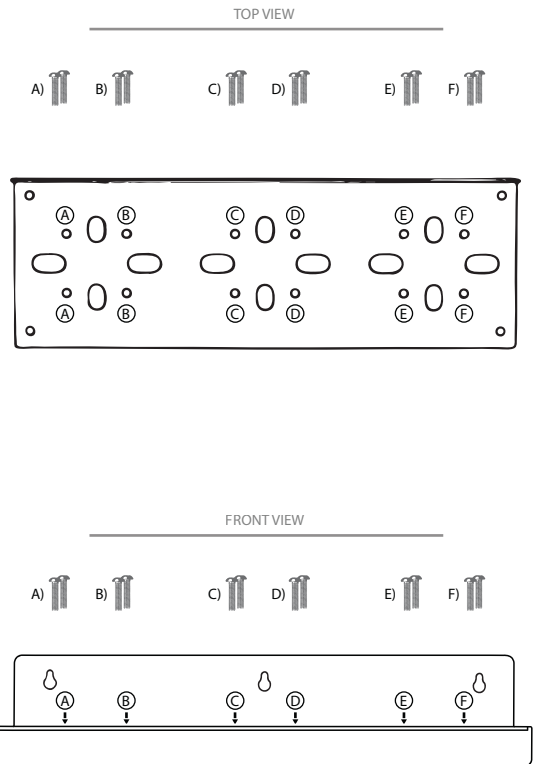

FIGURE B:

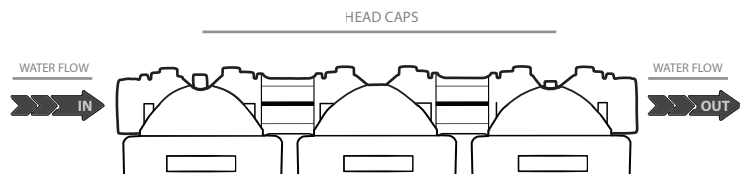
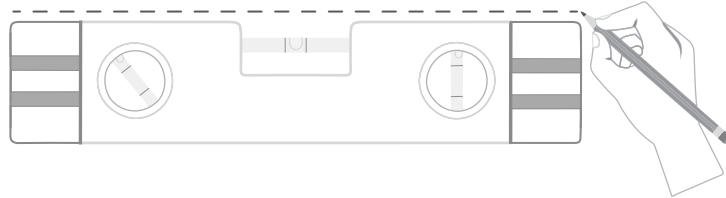

FIGURE C:

Installation

Mountain bracket:

- Avoid all kind of tensions by using wall brackets as a support.
- 1 Hold the spirit level against the wall in the desired location. Use a pencil to mark a line for the position of the mounting bracket on the wall.



- Make sure to counter the distance for the housing system above the ground.

- 2 Hold the bracket against the wall on the marked line. Use a pencil to mark the positions of the mounting holes on the wall. Make sure the bracket is level.

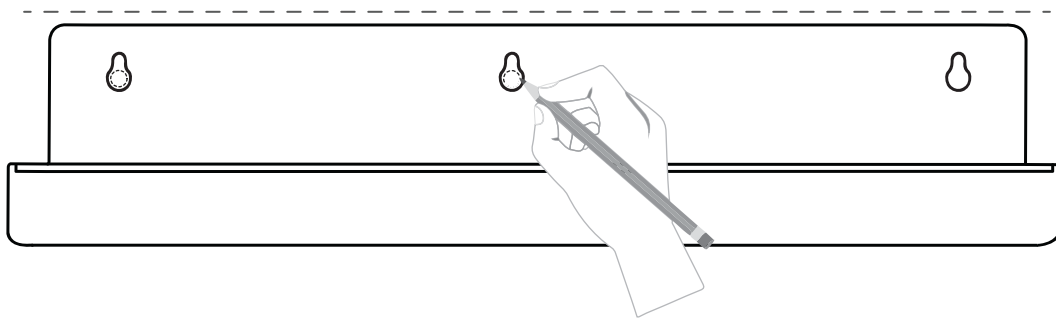

- 3 Using the marked points, drill pilot holes into the wall. If wall anchors are needed, insert them into the pilot holes.



- 4 Line up the bracket with the pilot holes and secure it to the wall using screws.

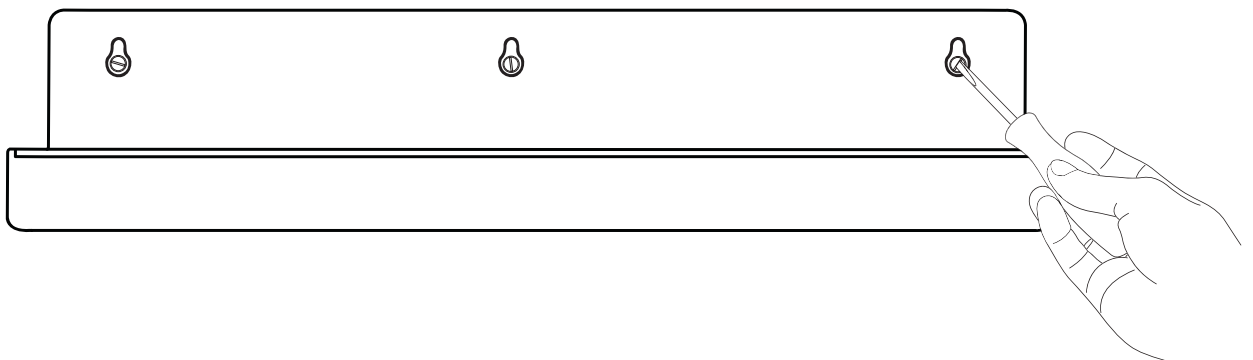

- Attaching the head caps to the mounted bracket using screws.

TOP VIEW

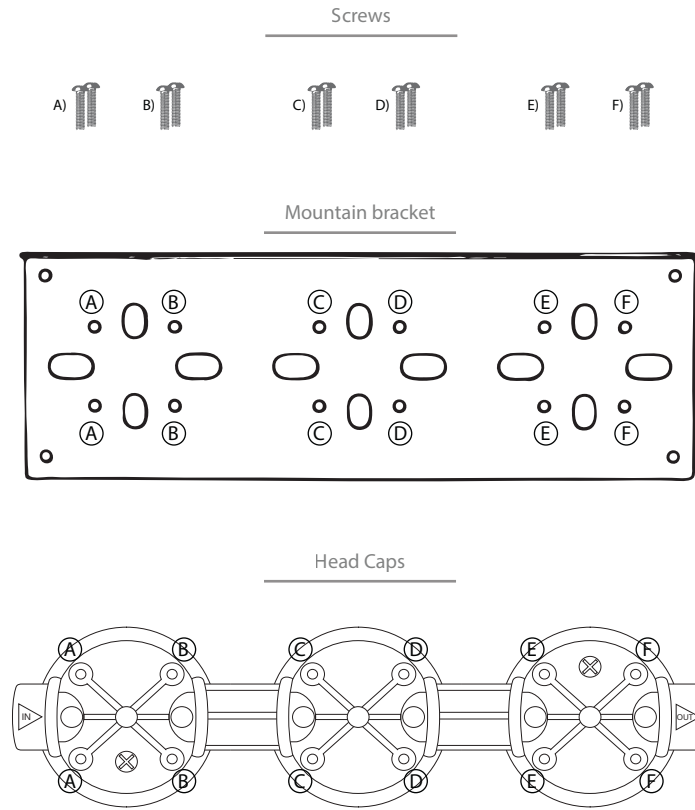

FRONT VIEW

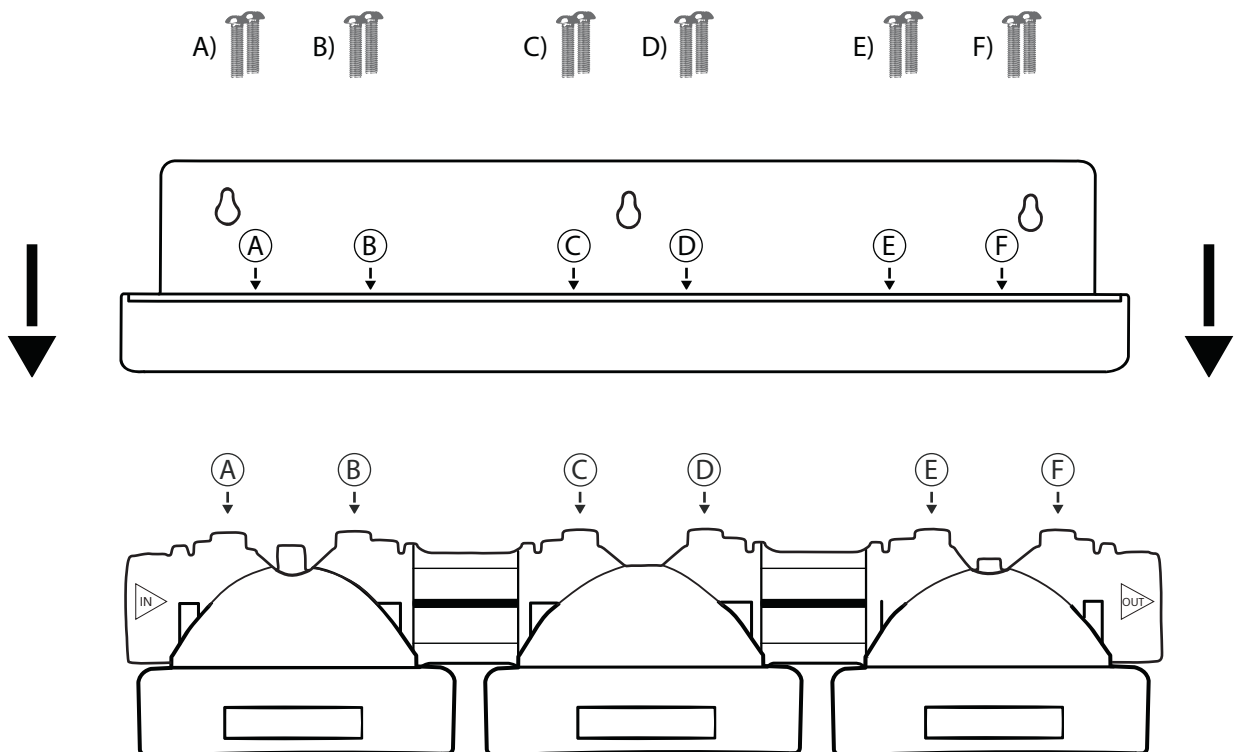
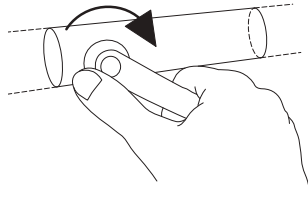

FIGURE C:

Installation

MWH-3 / UVH-3

- 1 Turn-off the water mains.



- 2 Connect the inlet to the product's side with the indication IN and the outlet to the side with the indication OUT.

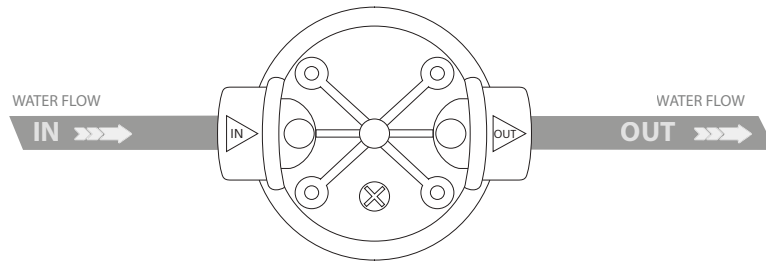

- 3 1" NPT (PVC) fittings should be threaded inside each end of the head caps.

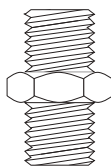

1" NPT Fittings.

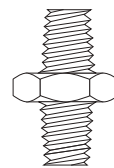

1" NPT Fittings.

FRONT VIEW

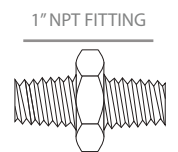
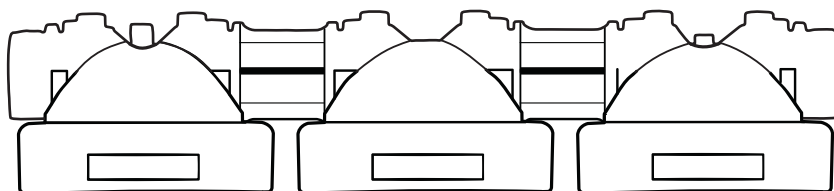
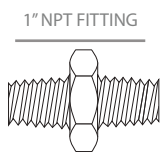

ANGLE VIEW

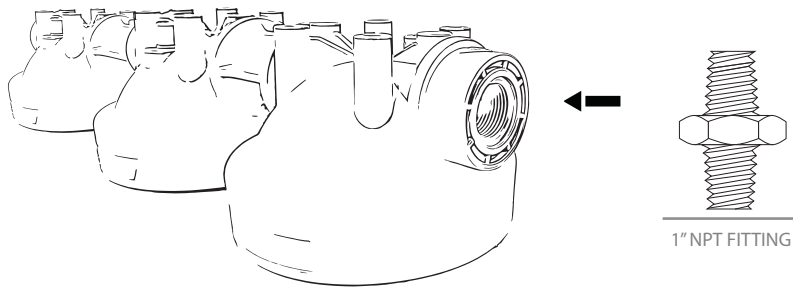

- 4 Use only sealing tape as a sealant for the connections.
- 5 The installation of a by-pass is recommended.
 - Note: by-pass installation kit isn't available, Please visit your local hardware store.

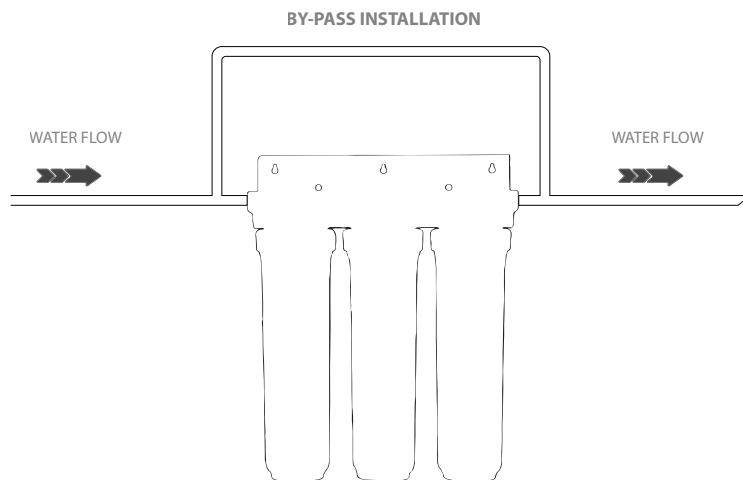

- 6 Install Filter Cartridge with lubricant /o-ring & tighten housing.
 - Carefully lubricate the housing o-ring which is located at the top bowl.

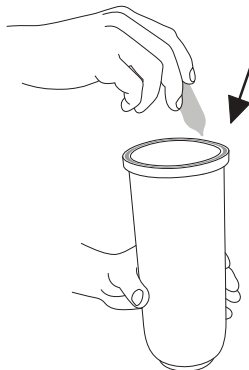

- Put every filter cartridge in it's specified housing.

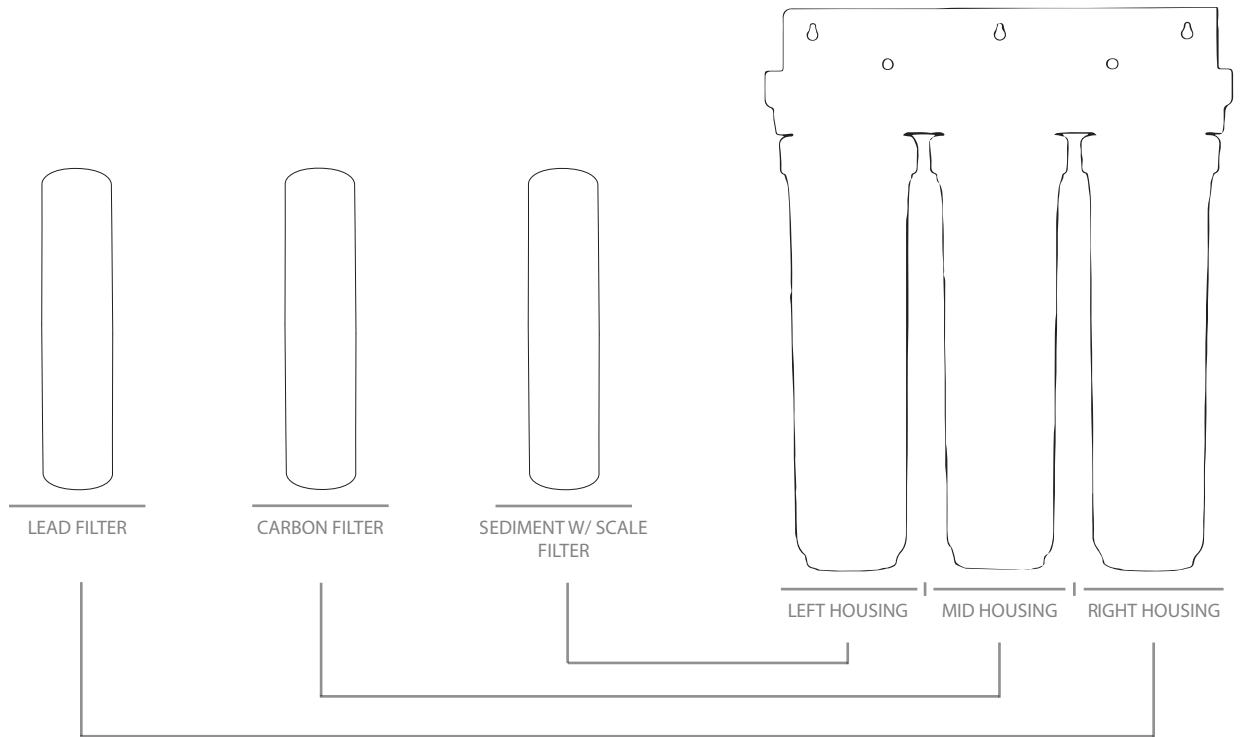

- 9 Turn-on the water mains.

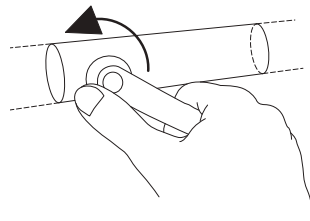

- 10 Vent the filter by unscrewing the breather valve, then retighten it.

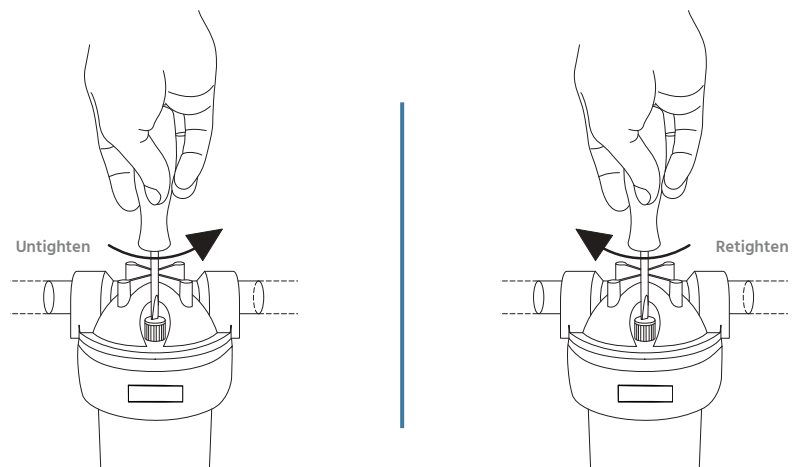

Package Content

FIGURE C:

PARTS LIST INDEX



A) Mounting bracket.

1X



B) Head caps.

1X



C) O-Rings & lubricant.

3X

D) Stainless steel button head screws.



*Only use for mounting bracket.

12X

E) Stainless steel tapcon screws.



*Only use for drywall, concrete, or brick walls.

3X

F) Stainless steel lag bolts screws.



*Only use for wooden surface

3X



I) Sediment w/ Scale filter.

1X



J) Carbon Filter.

1X



K) Lead Filter.

1X



H) Housing.

3X



G) Wrench.

1X

CONTROLLER

Your controller monitors system performance, Displays diagnostics, and provides safety Warnings. It will notify you when it's time For your annual lamp replacement. It also has our contact information For questions and concerns.



20" LEAD/VOCs FILTER

Our 0.5 Micron Lead/VOCs filter is perfect for enhanced Protection. Small tiny volatile organic compounds will be Filtered out. Additionally, Lead can be efficiently taken out Of your water supply down to 0.5 Micron.



20" UV SYSTEM

UV purification treatment for your home. A 316L stainless steel Polished tank, designed and manufactured to meet industry Standards encloses the UV lamp to provide outer protection. Attached is a UV sensor that is always monitoring The performance of the system. These diagnostics are displayed On our controller screen as well as all other relevant information.

PRESSURE RELEASE VALVE

This little screw is located on the top of The head caps. Simply unscrew the small Gray cap and it will slowly release Pressure from inside before performing A filter replacement.



20" SEDIMENT WITH SCALE FILTER

Sediment With Scale Filter technology Ensures water Filters down to 5-Microns With Scale Protection technology Eliminating scale buildup, Clogged Plumbing, Stained Faucets, Reduce Appliance Life, and contaminants, like Sediments, chlorine, and more.

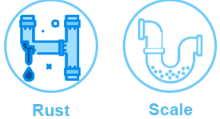

20" FILTER HOUSING

These housing sumps come in a beautiful Gray which is perfect for neutrality wherever You decide to install. They are made out of High density Polypropylene to ensure Complete protection from outside impact And efficient protection against outside Weather conditions.



20" CARBON FILTER

The Second stage of our system is a 5-micron carbon Block filter where the magic happens. Our highly Refined granular carbon media is tightly-packed inside This filter cartridge to treat Chlorine, Tastes, and Odors. This filter will also take out traces of VOCs, and metals Found in your water.



REN Water

Modern Filtration Solutions

HO 5.1



UV WATER PURIFICATION SYSTEM

- 5 to 40 GPM
- Colour screen controller
- Lightlock™ technology for protected lamp replacement sales

If you are looking for UV water treatment for your home, REN WATER has the solution in the HO series of residential UV systems.

REN WATER-HO provides UV water treatment for your home with the inclusion of a true 254nm Teflon® based UV sensor that continuously monitors the performance of the UV system, displaying the output via a colour screen (optional on 5.1 systems). In addition to UV output, diagnostics, system status, warnings and QR codes can also be displayed.

With the integral expandability port, the addition of a 4-20mA output or a solenoid valve is a simple plug-and-play option.

Product Features

- Free floating (no cable twist), keyed-in-place, 254nm Teflon® based UV sensor measures continuously, displaying UV intensity as a % – std. Optional on all LCD colour screen models
- Colour screen controller with Lightlock™ for protected lamp replacement, includes QR codes, full diagnostics & warnings
- Expandability port for future upgrades and options
- Axial flow, 316L stainless steel polished reactors, designed & manufactured to ASME pressure vessel standards
- Simple lamp changes
- Reliable, industry proven, proprietary low pressure, high-output, coated UV lamps with ceramic bases for durability and long life
- Constant current electronic controller in a splash proof case
- Full customization available as an option – language, home screen, phone number, QR codes, etc.

Sample Screens



Point-of-Use (POU)

RW-ULX41/46, for flow rates of 19 lpm (5 gpm)

Point-of-Entry (POE)

RW-ULX43/47, for flow rates of 38 lpm (10 gpm)

RW-ULX42/48, for flow rates of 57 lpm (15 gpm)

RW-ULX44/49, for flow rates of 95 lpm (25 gpm)

RW-ULX45/50, for flow rates of 151 lpm (40 gpm)

WWW.RENWATER.COM

Assembly

Unpack the system and ensure all the components are included with the system. Your system is shipped with the following components:

HO 5.1 (Standard output lamp systems)

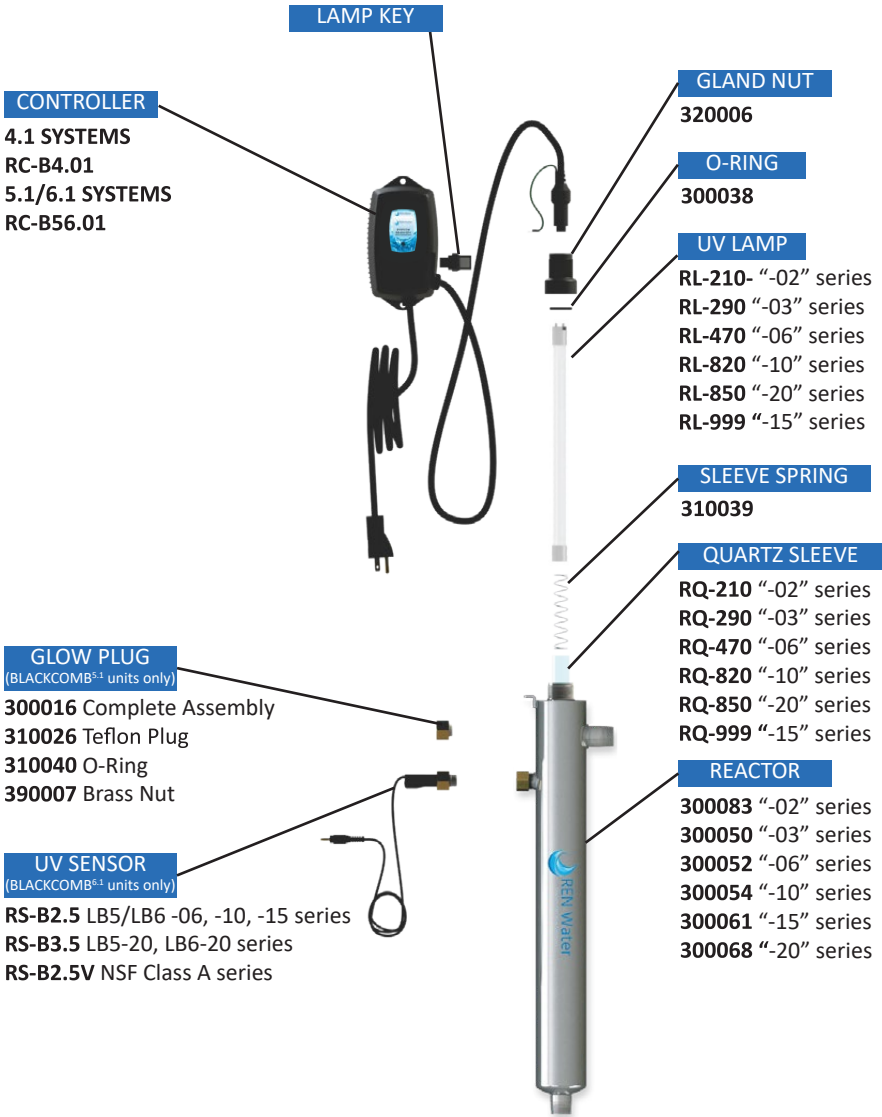



Figure 2. Lamp Removal Spacing

Installation

Step 1: The reactor can be installed either horizontally or vertically using the clamps provided. Vertical installation is the preferred method with the inlet at the bottom (lamp connection at the top) as it allows any air that may be in the lines to be easily purged from the system.

Step 2: The use of a by-pass assembly is recommended as it will allow you to isolate the UV reactor. This will allow for easier access in case maintenance is required (See Figure 4).

Step 3: Fasten chamber clamps to wall with screws provided. The screws must anchor securely into solid wood, concrete, or steel structure for adequate strength. Do not attempt to secure screws into drywall (Figure 3a). Install Chamber into clamps (Figure 3b).

Step 4: For water supplies where the maximum flow rate is unknown, a flow restrictor is recommended so that the rated flow of your particular HO 5.1 system is not exceeded. The flow restrictor should be installed on the inlet port of the reactor.

Step 5: It is recommended to have a licensed plumber connect the UV reactor to the water supply and may be a requirement depending on where you are located.



Figure 3a. Fasten clamps to wall



Figure 4. By-pass assembly

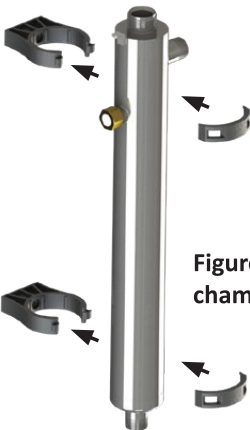

Figure 3b. Install chamber into clamps

Note: Installation of your HO 5.1 disinfection systems shall comply with applicable provincial/state & local regulations.**

Step 11: Always hold UV lamps by their ceramic ends, not by the lamp quartz. Remove the lamp from its packaging. Again, the use of cotton gloves is recommended. Remove the lamp key from the lamp's connector and set it aside for the next step. Be careful not to touch the key's exposed contacts. Insert the UV lamp into the reactor, being careful not to drop it.

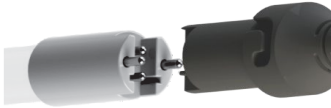

Figure 9a. Standard Output UV Lamp Connection



Figure 9b. High Output UV Lamp Connection

Step 12: Install the lamp key into the controller. The key always comes packaged with the lamp and sits on the connector. With the key removed from the lamp, orient it so the label is upright and facing you. The key will plug into the lamp key port on the right side of the controller (Figure 10).

Step 13: Plug the LUMI-Loc™ lamp connector into the lamp. Note the keying for proper alignment (see Figure 9a, 9b). Insert the lamp connector into the gland nut and turn the connector approximately ¼ turn to lock the connector to the gland nut as in Figure 11.



Figure 10. Lamp Key Installation



Figure 11. HO 5.1 Connector

Step 14: Tighten the captive ground screw to the ground lug on the UV reactor to ensure proper grounding.

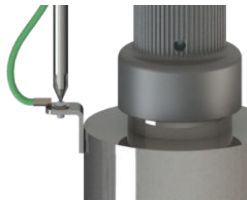

Figure 12. Ground Screw Connection

Step 15: Your system is now ready to be plugged into the appropriate GFCI protected outlet. Refer to the following section before any water is allowed to flow through the system.

System Sizing

REN Water UV systems are rated for a specific flow rate in water that meets the quality param **PLEASE NOTE** that increasing the flow above this rating or disinfecting efficacy of the system.

If you need to determine your maximum flow rate, you can fill a 1 gallon bucket with water and time how long it takes to fill up. It is always better to oversize your system than to undersize. For

Location

For Point of Entry (POE) systems, choose a location where the main cold water line is accessible. The system must be installed after other water treatment equipment (softener or filters), but

the faucet. **REN Water** recommends that a 5 micron filter be installed **before** final polishing step before the water is disinfected

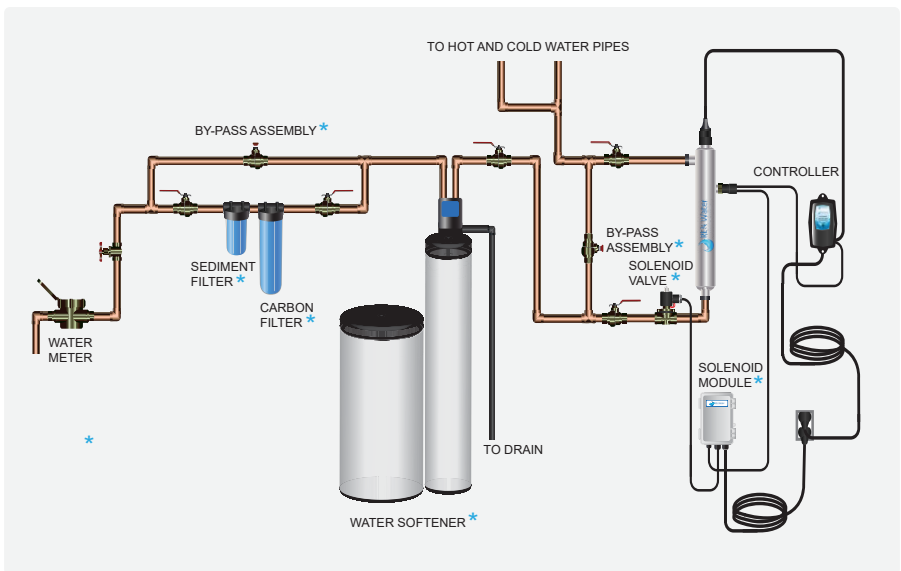









Figure 1. Recommended POE Installation Location

To facilitate lamp removal, ensure there is enough space at the lamp connector end to safely remove the UV lamp and/or quartz sleeve (See Figure 2). The controller will require a ground fault circuit interrupter (GFCI or GFI) outlet and should be mounted beside or above the reactor.







PLEASE NOTE: REN Water UV disinfection systems are intended for indoor use only as they should not be exposed to the elements.**

System Troubleshooting

Hard Alarms: The following give a constant audible alarm. If present, the solenoid valve is closed, and the 4-20, remote alarm and wifi modules transmit the alarm.

System Display	Problem	Resolution
 <p>lamp failure replace lamp</p>	<p>The system has detected a problem with the lamp.</p>	<p>Reset lamp protection circuit -unplug unit for 10 seconds. Replace the lamp with the part as indicated on the silver label on the reactor or on the Maintenance parts screen.</p>
 <p>lamp expired 1 days ago press button for lamp change info.</p>	<p>Although the lamp is powered and visibly illuminated, due to the lamp's age its UV output is no longer sufficient for proper disinfection**.</p>	<p>Replace the lamp with the part as indicated on the silver label on the reactor or on the Maintenance parts screen.</p>
 <p>UV OUTPUT 50% low UV check system</p>	<p>Low UV Intensity.</p>	<p>Remove and clean the quartz sleeve and sensor. Check water quality meets requirements on page 5 and add filtration as required. Replace lamp.</p>
 <p>LAMP INCORRECT Required Part: RL-470 Installed Part: RL-290</p>	<p>Wrong lamp or sensor installed.</p>	<p>Replace component with proper model as indicated.</p>
 <p>UV SENSOR FAILURE check connection or see manual</p>	<p>The UV sensor is no longer communicating with the system.</p>	<p>Ensure all modules are connected properly to the system and to each other.</p>
 <p>CONNECTION FAILURE check connection or see manual</p>	<p>A bad connection has been detected in the IEP port.</p>	<p>Modules can be tested individually by plugging in one at a time and cycling power to the system.</p> <p>Replace any module that is not detected when plugged directly into the controller.</p>
 <p>LAMP KEY NOT FOUND check connection or see manual</p> <p>LAMP KEY INVALID check connection or see manual</p>	<p>Missing or incorrect lamp key.</p>	<p>Ensure the lamp key (packed with the lamp, on the connector) is installed. Unplug and reinstall the key. Ensure the key part number matches Lamp on Maintenance Parts screen.</p>

Soft Alarms: The following remaining errors give a 15 second audible chirp only

System Display		Problem	Resolution
 <p>SOLENOID FAILURE</p> <p>check connection or see manual</p>	 <p>4-20 mA FAILURE</p> <p>check connection or see manual</p>	<p>The module indicated is no longer communicating to with the system.</p>	<p>Ensure all modules are connected properly to the system and to each other.</p> <p>Modules can be tested individually by plugging in one at a time and cycling power to the system.</p> <p>Replace any module that is not detected when plugged directly into the controller.</p>
 <p>REMOTE ALARM FAILURE</p> <p>check connection or see manual</p>	 <p>WIFI FAILURE</p> <p>check connection or see manual</p>		
 <p>FLOW METER FAILURE</p> <p>check connection or see manual</p>		<p>Refer to flow meter manual for detailed troubleshooting</p>	

Warning: After any hard alarm, the home or facility should be disinfected**. Follow the steps under the “System Preparation” heading.

Boil Water Advisory: If any failure occurs on a BLACKCOMB UV system, the water must not be used for human consumption until the system is returned to normal operational mode. If the water is used for human consumption during this period, the water must be boiled (minimum 20 minutes at a full boil) prior to consumption.

Temperature Management Devices

Your **REN Water** HO 5.1 system is designed to run continuously to ensure optimal disinfection**. However, during periods when no water is drawn through the system, the energy from the disinfection** process can cause the temperature of the water inside the chamber to rise. In extreme situations elevated water temperature or the fluctuation in temperature can lower the output of the UV lamp. In these cases, or if the elevated water temperature is a nuisance, **REN Water** recommends one of the following forms of temperature management devices.



Cooling Fan

Designed for use on the HO 5.1 systems, the “LUMI-cool™” fan runs continuously to cool the water by forced convection. The long-life fan is powered independently using a compact modular power adapter that operates from 100-240V/50-60Hz. ±10%. The cooling fan must only be supplied at SELV. Order PN **130014**.



Temperature Relief Valve (TRV)

On reaching a higher temperature, the TRV is designed to drain a small amount of water to allow fresh, cooler water to enter the system. The TRV works without power and comes complete with 10’ of drain line. Order PN **130031** for 1/2” ports, PN **130032** for 3/4” ports, PN **130033** for 1” ports and PN **130034** for 1 1/2” ports.

Expansion Modules

HO 5.1 controller incorporate an “Infinite Expandability Port” (IEP) which allows for expansion to the UV sensor and all other modules. Each module (including the sensor) comes with both a male and female connection. Connect any device to the controller and all subsequent devices are then connected into the female end of last device added in a “daisy chain” configuration. The UV sensor must only be supplied at SELV.



The following optional expansion modules are available for use on HO 5.1 UV controller.



REMOTE ALARM CONNECTION MODULE: Allows for a connection to a remote device such as a buzzer, light, alarm system, PLC, etc., via a pair of contacts. In normal operation the OK and COM contacts will be connected, and in a fault condition (Low UV, Lamp fail, Power Fail), the Fault and COM contacts will be connected. Maximum contact rating is 30V / 1A (use 16-22 AWG). The remote alarm module must only be supplied at SELV. Order PN **MOD-RAM**.

Typical POE Installation

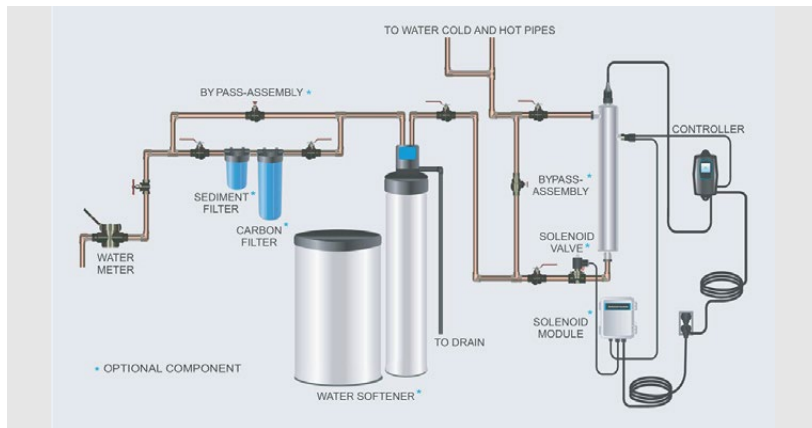

HO - Equipment Specifications

Model	RW-ULX41 RW-ULX46	RW-ULX43 RW-ULX47	RW-ULX42 RW-ULX48	RW-ULX44 RW-ULX49	RW-ULX45 RW-ULX50
Flow Rate (30mJ/cm ²) @ 95% UVT	5 GPM	10 GPM	15 GPM	25 GPM	40 GPM
	18.91 lpm	37.9 lpm	57 lpm	95 lpm	151 lpm
	1.1 m ³ /hr	2.3 m ³ /hr	3.4 m ³ /hr	5.7 ³ /hr	9.3 m ³ /hr
Flow Rate (16mJ/cm ²) @ 95% UVT	8 GPM	19 GPM	27 GPM	47 GPM	78 GPM
	30.3 lpm	71.9 lpm	102.2 lpm	178 lpm	295 lpm
	1.8 m ³ /hr	4.3 m ³ /hr	6.1 m ³ /hr	10.7 m ³ /hr	17.7 m ³ /hr
Flow Rate (40mJ/cm ²) @ 95% UVT	3 GPM	7 GPM	11 GPM	19 GPM	31 GPM
	11.4 lpm	26.5 lpm	41 lpm	72 lpm	117 lpm
	0.7 m ³ /hr	1.6 m ³ /hr	2.5 m ³ /hr	4.3 m ³ /hr	7.0 m ³ /hr
Port Size	1/2" MNPT	3/4" MNPT	1" MNPT	1" MNPT	1 1/2" MNPT
Electrical	100-240V/50-60Hz. ±10%. 1.5A Max.				
Plug Type	American: NEMA 5-15P				
Lamp Watts	18	34	45	67	101
Power (Watts)	20 (19 @ 230V)	38 (36 @ 230V)	57 (48 @ 230V)	73 (72 @ 230V)	115 (108 @ 230V)
Replacement Lamp	RW-ULX153	RW-ULX156	RW-ULX159	RW-ULX162	RW-ULX165
Replacement Sleeve	RW-ULX244	RW-ULX246	RW-ULX247	RW-ULX249	RW-ULX252
Chamber Material	316L Stainless Steel, A249 Pressure Rated Tubing, Polished & Passivated				
Reactor Dimensions	3.5 x 11.7" (8.9 x 29.8cm)	3.5 x 16.5" (8.9 x 41.8cm)	3.5 x 20.0" (8.9 x 50.8cm)	3.5 x 26.9" (8.9 x 68.3cm)	3.5 x 40.7" (8.9 x 103.4cm)
Controller Dimensions	8.6 x 4.2 x 4" (21.7 x 10.8 x 10.2 cm)				
Operating Pressure	0.7-10.3 bar (10-150 psi)				
Operating Water Temp	36-104° F (2-40° C)				
UV Monitor	OPTIONAL on all LCD colour screen models. NOT available on LED models.				
Solenoid Output	YES (optional solenoid module sold separately)				
Dry Contacts	YES (remote alarm module sold separately)				
4-20mA Output	YES (4-20mA module sold separately)				
Lamp Change Reminder	YES (both audible and visual (full colour graphic))				
Lamp Out Indicator	YES (both audible and visual (full colour graphic))				
Shipping Weight	9.9 lbs (4.4 kg)	11.5 lbs (5.2 kg)	12.9 lbs (5.6 kg)	15.5 lbs (7.0 kg)	21.1 lbs (9.6 kg)

Manufacturer's Warranty

REACTORS—Ten (10) year Limited Warranty

ELECTRONICS—Three (3) year Limited Warranty

UV LAMPS—One (1) year Limited Warranty

QUARTZ SLEEVES—One (1) year Limited Warranty



Contact **Ren Water** for complete warranty document, including conditions and exclusions.

Guaranteed OEM Lamp Replacement with Lightlock™ technology

Protect your replacement lamp revenue stream with REN WATER's truly proprietary UV lamps with Lightlock™ technology. Maintain your lamp sales, and more importantly your lamp margin, all while protecting the integrity of the product and its performance.



Optional Equipment Modules

UV Concierge

Available for WEB, iOS, and Android platforms providing live, dynamic feedback on all features and functions of your UV system.



SHERPA Series Water Quality Monitor

Allows for remote monitoring of all major and minor alarms that take place on the UV system. Three LED's visually display system functionality from up to 150' (46m) away.



Custom Dealer Programmer

Customize your UV controller with your own company name, logo, website, QR code and contact information. Capture the lucrative replacement lamp market by creating a direct link back to your own website!



UV Sensor Module

Allows the UV intensity to be measured and displayed via the controller. The sensor plugs directly into the controller and is mounted in the sensor port located on all reactors. (see chart for part numbers)



Solenoid Module

Used to power a remote normally closed solenoid valve (not included). Solenoid will close on lamp failure or when low UV conditions are detected by the sensor. Available in 110V. (MOD-SOL1) or 230V. (MOD-SOL2)



TRV (temperature management relief valve)

TRV allows for a small amount of water to be physically released (dumped) from the UV unit to allow for cooling of the water. Used in applications of extended "no flow" conditions, or when the temperature of the treated water is of a critical nature.



4-20mA Module

Used for signal transfer to a remote device such as a data logger or computer. Order MOD-420.



Remote Alarm (Dry Contact) Module

Used for signal transfer to a remote alarm or dry contacts. Order MOD-RAM.



REN WATER LLC

836 Bill France Blvd
Daytona Beach, Florida
32117

1-800-240-5574
www.renwater.com

