

# WATER FILTER MWH-2

## INSTALLATION AND MAINTENANCE MANUAL

### Welcome to RENWater!

Congratulations on choosing our state-of-the-art water filtration system to enhance the quality of water in your home. Our commitment is to provide you with a reliable and efficient solution for pure, refreshing water.

For additional support or inquiries, visit our website at [renwater.com](http://renwater.com) or contact us at [sales@renwater.com](mailto:sales@renwater.com)

#### General direction for use

- Use only for filtration of water with pH from 6.5 to 9.5. In case of water with pH below or above the limits use only housings marked as pure polypropylene (PP).
- In case of filtration of drinking water, do not use with unsafe water or with water of unknown quality without adequate disinfection before or after the filter.
- Keep protected from light, install under direct light only models with opaque bowl.
- Keep protected from back-flows with a non-return valve.
- Keep protected from water hammer with an anti-water hammer device. In case of installation on systems powered by a pump and especially on those equipped with a pressure and flow controller, an additional expansion vessel must be installed upstream the filter to protect it from eventual repeated pressure peaks (figure C).
- Do not install near to electric appliances.

**WARNING:** Respect the working conditions, as shown in the sticker affixed to the product. If the sticker is tampered, damaged, not legible or missing, applicable working conditions are: maximum operating pressure 8 bar (10 bar for filters with metal/brass head), maximum operating temperature 45°C (80\* for filters marked HOT); minimum operating temperature 4 °C. If pressure exceeds the working conditions, protect the product with a pressure reducer.

#### Installation guidelines

- Install the products in sheltered rooms and protected from freeze and excessive heat.
- Before the installation, check if the hydraulic system has been set-up according to the rules-of-the art in force.  
Refer to figures:
  - A Mounting bracket top and front view lay-out.
  - B IN - OUT directions presentation in filter housings head caps.
  - C Installation.
  - D hardware parts list lay-out.
- \* For products with pressure gauges: apply sealing tape on threads of the pressure gauges and then screw them, do not overtighten, onto 1/8" of the threaded connection at the top of the head; when the filter is set operational, if water is leaking, add sealing tape or screw tighter. For models with brass head, unscrew the caps at the top of the head and screw the pressure gauges according to the procedure indicated above.
- \* For products with plugs (screws) for pressure gauges: screw the plugs (provided with o-rings) on tightly.
- \* For products with drain kit: screw the plastic nipple with o-ring to the threaded connection for the drain at the bottom of the container, screw the ball valve onto the nipple, after having made sure there is a gasket, then screw the ball valve to the drain funnel or to the hose connector tube, after having made sure there is a gasket.
- \* For products with drain plug: screw the plug on tightly.

#### Maintenance

- Periodically clean with cold water and a soft sponge. Replace the filter cup every 5 years at least.
  - Before opening: turn-off water mains and release the pressure by un-screwing the vent-valve on housing head. Then screw and tighten the vent-valve.
  - If not in use for a long time: remove the cartridge; when re-using apply a new cartridge.
  - Check the housing tightening, if water leaks between sump and head lubricate the o-ring or change with a new one.
- >t Remark: after the maintenance, let the water flow for at least 5 minutes before the use.

#### Replacement of the cartridge

Follow standards in force regarding waste disposal of used cartridges,

1. Before opening the filter housing turn-off the water mains.
2. Release the pressure from the product by un-screwing the vent-valve of the head. Then screw and tighten the vent-valve
3. Open the housing unscrewing the housing using a proper wrench.
4. Remove the used cartridge.
5. Wipe clean the filter housing with cold water and a soft sponge.

6. Open the new cartridge wrap and discard wrap.
  7. Put a new cartridge in the container.
  8. Tighten the housing bowl to housing's head using a proper wrench. Do not over-tighten.
  9. Turn-on the water mains.
  10. Slowly turn-on a water supply (tap) downstream the filter.
  11. Wait for air purge from the vent-valve, then screw and tighten the vent-valve.
- > Remark: let the water flow for at least 5 minutes before the use.

**WARNING:** at re-start after every maintenance operation and/or refill change, when the filter's bowl is unscrewed from head, change the o-ring with a new one and carefully lubricate before tightening the bowl to the head. Make sure that there are no water leaks from the product and especially control the tightening between the housing head and the housing bowl. Continue checking that the tightening is good and there is no water leakage for 48 hours following the installation and start-up. In case of leakage, open the housing, remove the o-ring from the bowl, place a new o-ring and apply lubricant, then re-tighten the bowl to head and repeat the leakage check as above.  
Ask your vendor for original o-rings, lubricant and other spare parts.

FIGURE A:

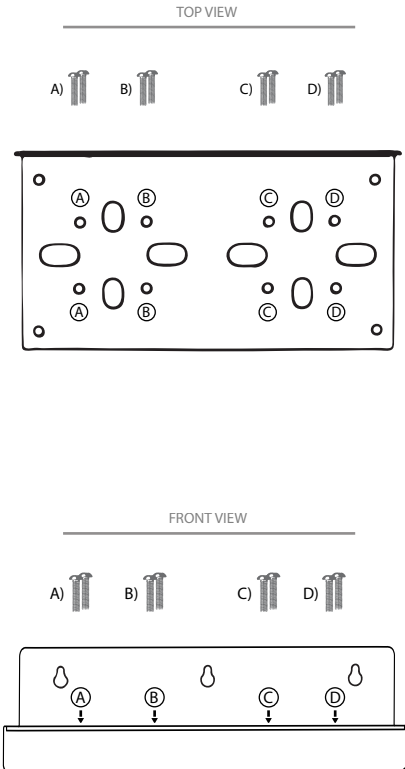

FIGURE B:

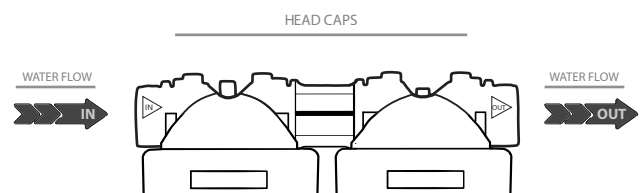

FIGURE C:

## Installation

Mountain bracket:

- Avoid all kind of tensions by using wall brackets as a support.

- 1 Hold the spirit level against the wall in the desired location. Use a pencil to mark a line for the position of the mounting bracket on the wall.

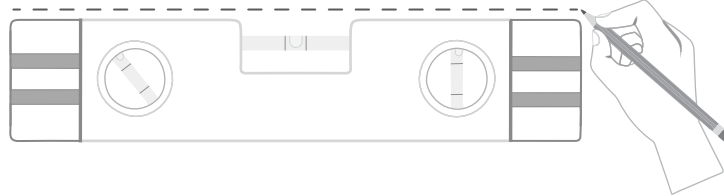

- Make sure to counter the distance for the housing system above the ground.

- 2 Hold the bracket against the wall on the marked line. Use a pencil to mark the positions of the mounting holes on the wall. Make sure the bracket is level.

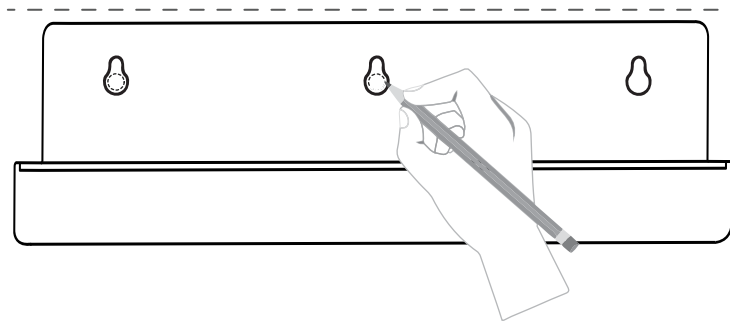

- 3 Using the marked points, drill pilot holes into the wall. If wall anchors are needed, insert them into the pilot holes.



- 4 Line up the bracket with the pilot holes and secure it to the wall using screws.

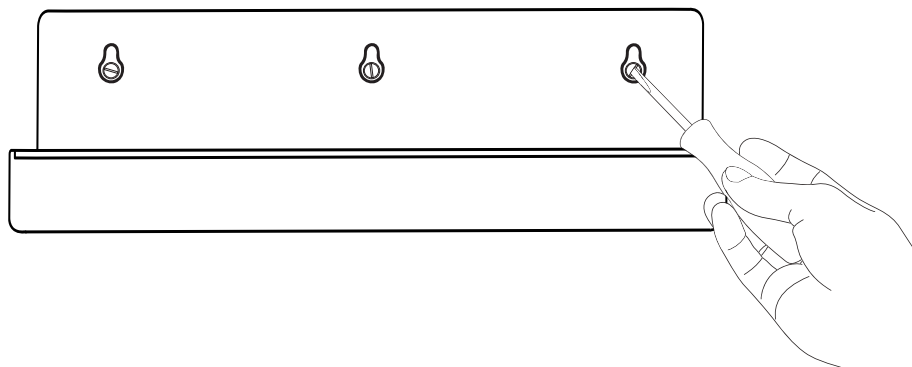

- Attaching the head caps to the mounted bracket using screws.

TOP VIEW

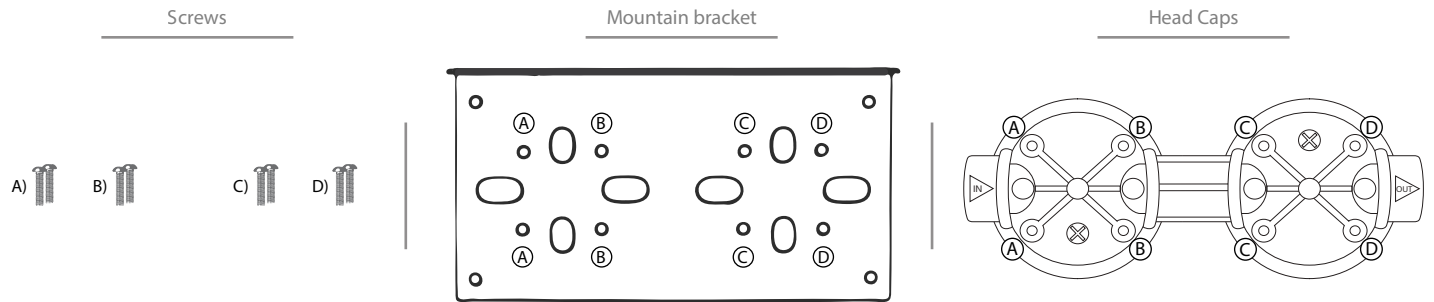

FRONT VIEW

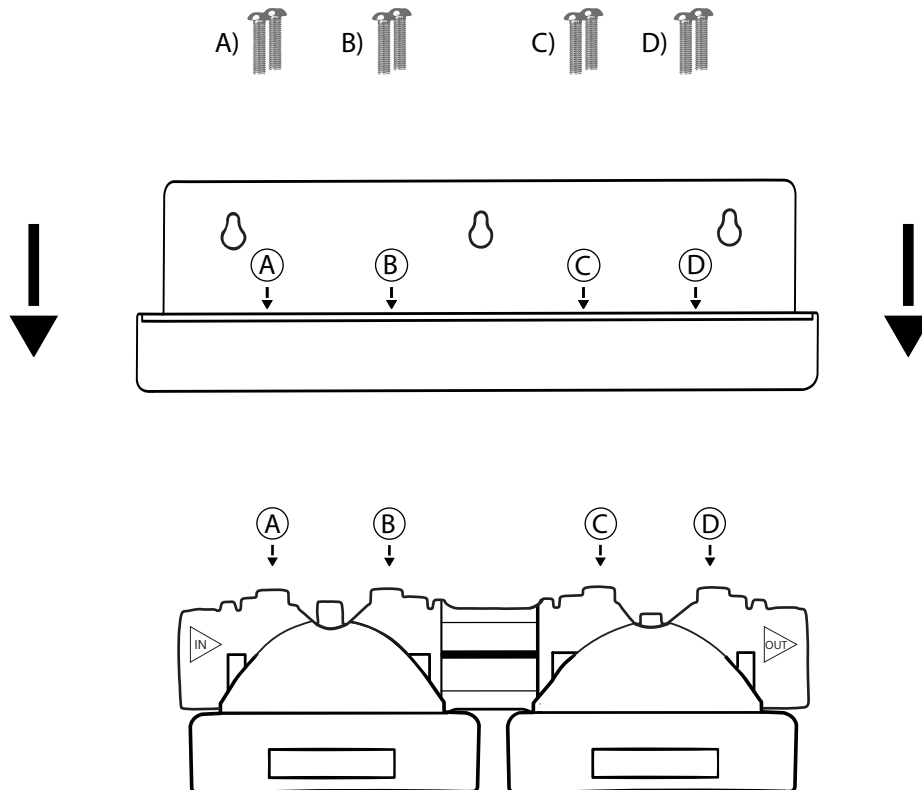
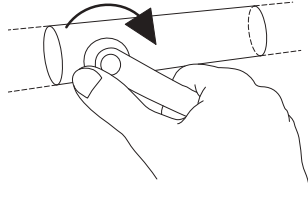

FIGURE C:

## Installation

MWH-2

- 1 Turn-off the water mains.



- 2 Connect the inlet to the product's side with the indication IN and the outlet to the side with the indication OUT.

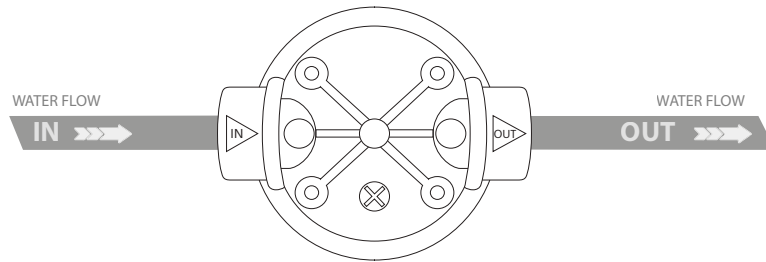

- 3 1" NPT (PVC) fittings should be threaded inside each end of the head caps.

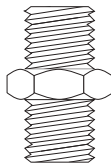

1" NPT Fittings.

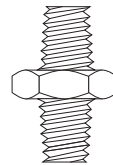

1" NPT Fittings.

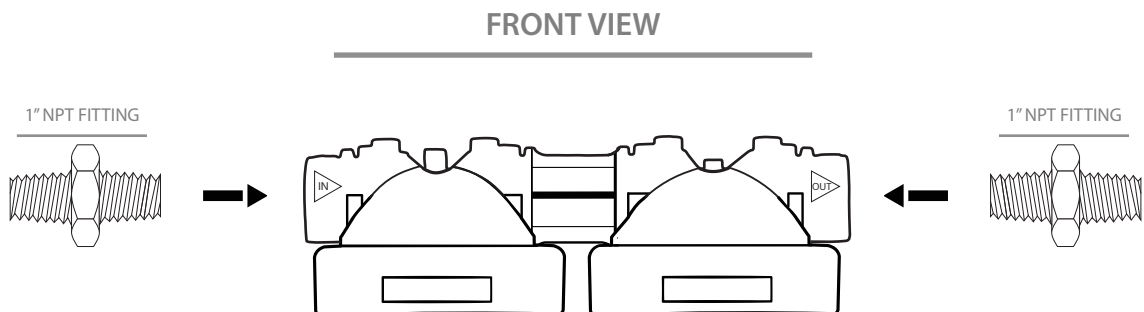

## ANGLE VIEW

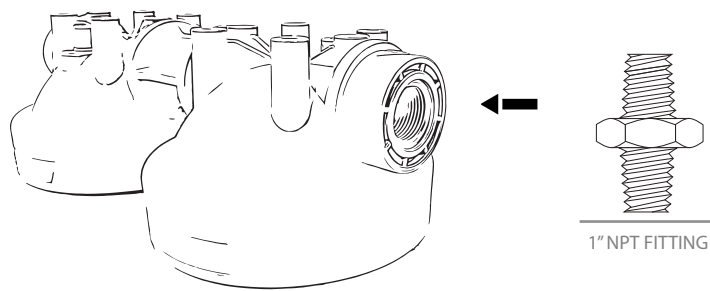

- 4 Use only sealing tape as a sealant for the connections.
- 5 The installation of a by-pass is recommended.
  - Note: by-pass installation kit isn't available, Please visit your local hardware store.

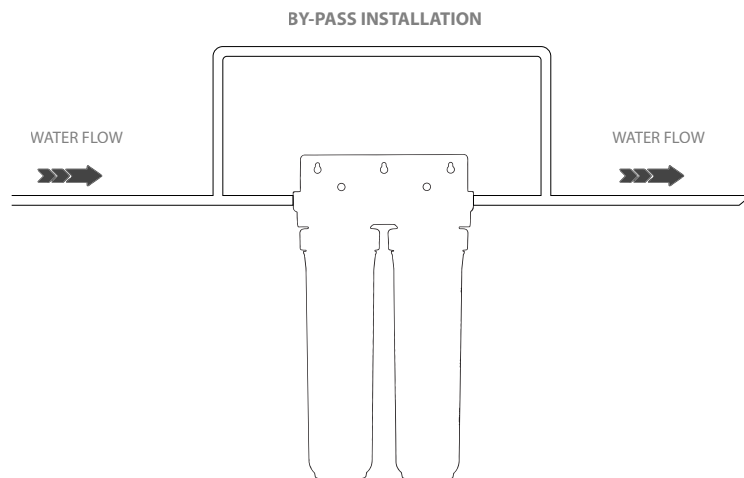

- 6 Install Filter Cartridge with lubricant /o-ring & tighten housing.
  - Carefully lubricate the housing o-ring which is located at the top bowl.

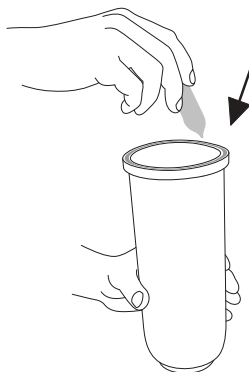

- Put every filter cartridge in it's specified housing.

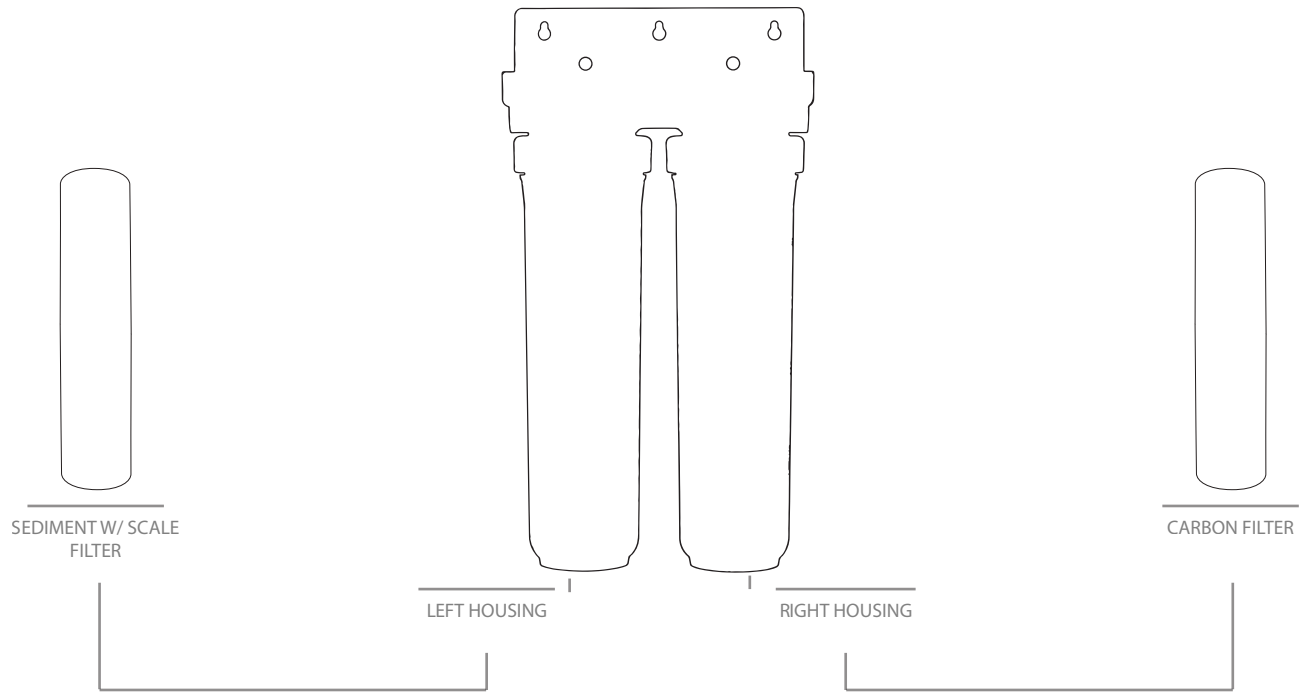

- 9 Turn-on the water mains.

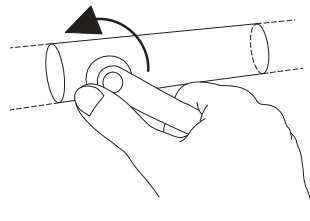

- 10 Vent the filter by unscrewing the breather valve, then retighten it.

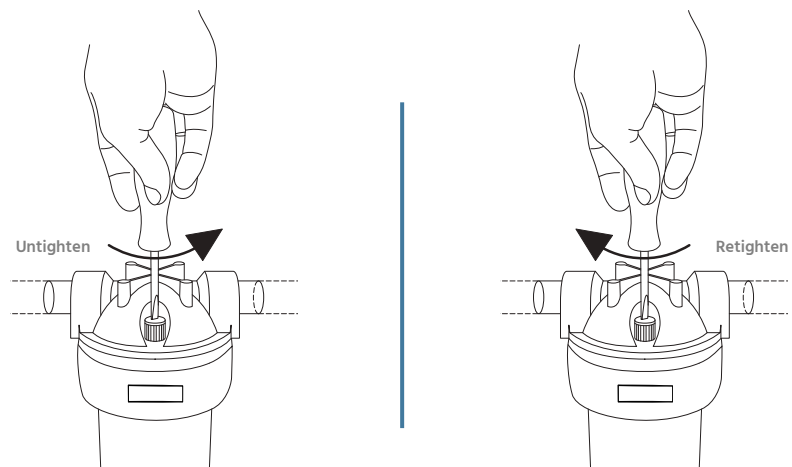

# Package Content

FIGURE C:

## PARTS LIST INDEX



A) Mounting bracket.

1X



B) Head caps.

1X



C) O-Rings & lubricant.

2X

D) Stainless steel button head screws.

\*Only use for mounting bracket.



8X

E) Stainless steel tapcon screws.

\*Only use for drywall, concrete, or brick walls.



3X

F) Stainless steel lag bolts screws.

\*Only use for wooden surface



3X



I) Sediment w/ Scale filter.

1X



J) Carbon Filter.

1X



G) Wrench.

1X



H) Housing.

3X