



GRP
ROOFING
SOLUTION

5 STEP GUIDE



A 5 step reference guide for installers.

The Metrodeck Roofing System is a wet laid roofing system consisting of a GRP laminate which is finished around the perimeter with pre-formed GRP edge trims and coated with a roofing topcoat.

image courtesy of Pro-fibre

CHOOSING THE RIGHT MATERIALS

Which Mat to Use?

The minimum specification is based on a reinforcement of 1 layer of 450g chopped strand matting, and this is adequate for most flat roofs providing the correct amount of resin is used and sufficient consolidation of fibreglass is obtained. We recommend a minimum specification of 1 layer of 600g matting, as well as being stronger, the extra fibreglass and resin will reduce the chance of installation errors.

If you are constructing a roof that is going to be regularly walked on such as a balcony, two layers of 450g mat would be recommended as it will provide more strength.

WHAT TOOLS WILL YOU NEED?

Mixing Buckets

Paint Brushes

Medium pile rollers

Short pile rollers

Paddle Roller

Extension Handle

Mixing sticks

Measuring cup

Catalyst Dispenser

(optional)

Acetone

Gloves

Goggles

Overalls



LAMINATING / TOPCOATING PROBLEMS

Wet weather

Should it rain while the resins or topcoats are liquid this is a difficult position to be in, stop work and cover what you have done immediately. Water will contaminate the resin and prevent it from curing.

If it rains at any point after the resins or topcoats have started to change from a liquid to a solid, although not ideal, it should be OK. Any rain falling will settle on top and not mix so the resins should still complete their cure. However it is very likely that gas (styrene) given off while the resin is curing will still react with the water. This will manifest itself as a white coating that appears on the surface of your fibreglass or topcoat layer. If this happens at the fibreglass stage, dry the surface and wipe down with acetone as this should remove most of the white coating, check all areas have cured, sand down with heavy grit paper, clean and apply the topcoat as normal.

Weather conditions

It is very important to check weather conditions and temperatures before starting GRP application. It is advisable to avoid working in the rain. A check on the average temperatures forecast is also important to ensure that the correct amount of catalyst is mixed into the resins and topcoats.

Catalyst mixing

If the resin or topcoat is not mixed with the correct amount of catalyst, it can have several detrimental effects.

Too little catalyst can lead to uncured resin or topcoat which can mean that the resin or topcoat will remain soft and will not provide a totally hard and waterproof surface.

Too much catalyst can cause the resin to cure too fast which can lead to exotherm and damage to laminate. Too much catalyst in topcoat can also mean that it cures too quickly, which prevents the wax additive to come to the surface of the topcoat which can then leave a tacky, uncured finish.

Streaky Topcoat

This can be caused by poor mixing of the topcoat before adding the catalyst. All topcoats and resins need to be stirred thoroughly before the addition of catalyst, to ensure all additives, i.e. pigment, wax, styrene, are thoroughly mixed in to prevent colour streaking and poor curing resins and topcoats.

Wetting out

It is vitally important to ensure that every part of the fibreglass mat is completely wetted out. Dry patches can lead to problems. Laminate that has not had the resin completely infused into the fabric can have areas that will leak. The fibres of the dry area can force upwards through the applied topcoat and water can then run down the fibre and cause a leak. When topcoat is applied to the area and cures, it can shrink back to create a patchy area of topcoat, which again can lead to leaks and cosmetic discrepancies.

Topcoat cracks

If topcoat is applied too thickly it is liable to crack. The area would need to be sanded down and cleaned well with acetone. A new topcoat will need to be applied at a thickness of 0.5mm.

Pinholes

Pinholes occur where there are gaps in the fibreglass mat. This can be due to incomplete wetting out of the fabric. They will appear in the topcoat as tiny pinholes, which can be seen in the topcoat. They can be rectified by sanding the area of topcoat and reapplying a new layer to seal the pinholes and prevent the leak.

Topcoating timeframe

If you are unable to complete the roof in one hit, there is an ideal time frame for applying the topcoat to ensure a full chemical bond. This time frame is 48 hours from when the laminate is stable enough to walk on, i.e. cured. If you apply the topcoat after this time, you will have to give the laminate a good key before applying topcoat. It is recommended that you wipe the surface with acetone to remove any debris. Allow the acetone to evaporate away, and then you are ready to apply the topcoat.

APPLICATION/CONSTRUCTION

Step 1. Deck.

We recommend only 18mm OSB3 decking 2400mm x 600mm tongue and groove, its surface is particularly good for maximum adhesion of resin, the slotted joints increase roof strength and are much quicker and easier to fit than 2400mm x 1200mm cut edge boards. Do not use any chipboard based decking.

The first step to start your fibreglass roof is to lay the OSB boards onto the joists. The tongue and groove boards should be laid at 90° to the roof joists. It is important to have the boards laid with the gap side of the tongue and groove facing upwards. This will allow the resin to flow between the boards and glue them together. The OSB boards should be staggered to allow a strong deck to be built. When all the boards are aligned in rows the joints become weak and can move over time. Boards are attached to joists using a nail gun or screws at 200mm centres and fixings must penetrate the joist a minimum of 40mm. For a warm roof, the top deck is attached with sufficiently long screws to penetrate the lower deck. Ensure extra fixings are used here to prevent deck movement.

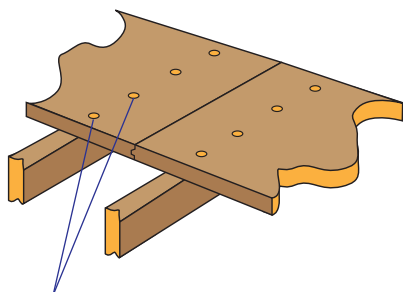

Boards should be fixed at 200mm centres

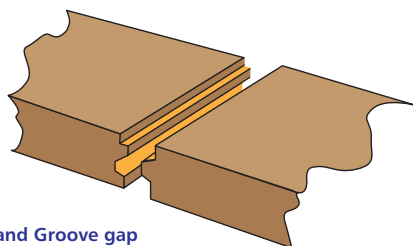

Tongue and Groove gap should always face up

Step 2. Trims.

Trims need to be fixed to the deck and can be done by using galvanized clout nails or staples. PU adhesive is used to secure the trims to a supporting batten at the front. Where trims need to be joined, this should be done by using a bead of PU Adhesive and the joint is finished using a strip of matting or fibreglass tape and resin.

TRIM TYPES

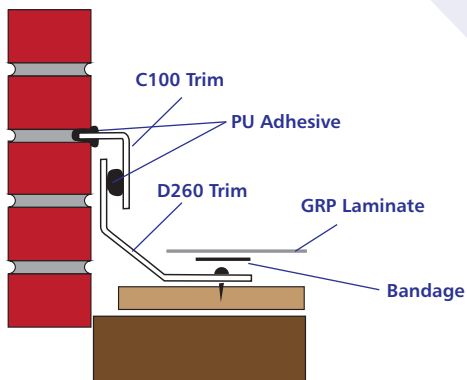
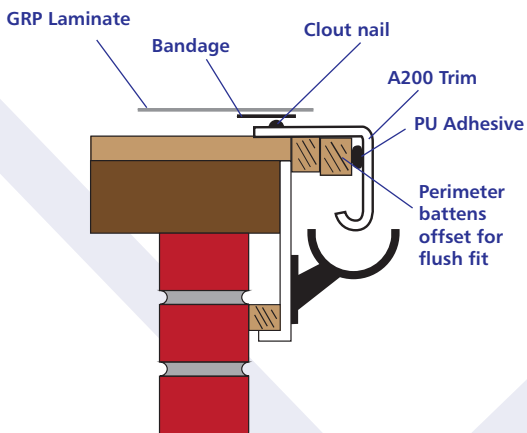
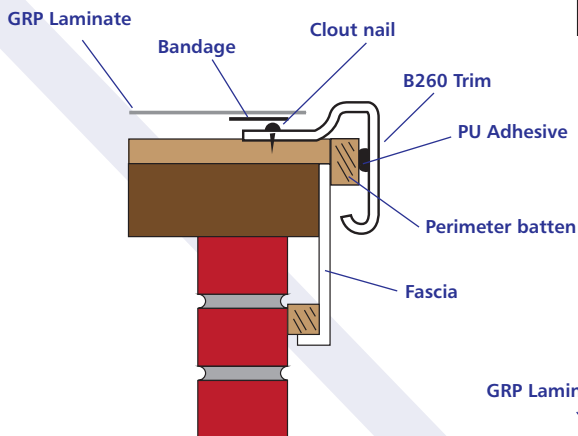
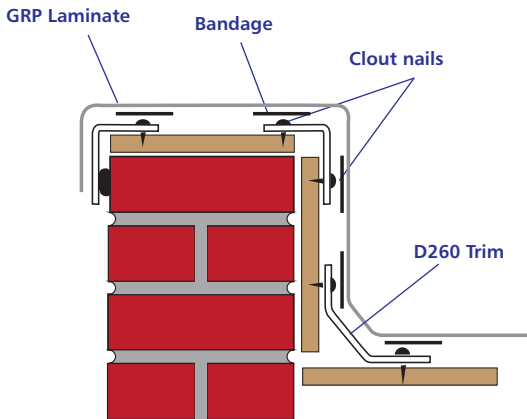

Step 3. Bandaging

Before laying the fibreglass mat, cover the edges of trim that meet the deck with a strip of fibreglass tape or fibreglass mat bandage. This will help to seal the edge of the trim to the deck. To do this, roller a thin layer of resin over the deck and trim edge and then apply the tape. Wet out the tape and roller with a paddle roller, until the resin is well absorbed into the glass.

Step 4. Laminating - Prepare the matting.

Ideally you should orientate your matting parallel to the drip edge, with the first 'run' starting at that side, but this is for cosmetic reasons, matting is random stranded so structurally it is not essential to worry about roll direction. Roll out the matt across roof and cut to length (this will be 50mm onto the edge of the trim). Matting will have one cut edge and one 'feathered' edge, the feathered edge should always overlap cut edges by 50mm. Repeat until you have enough prepared rolls to start work. For 2 layer roofs the matting can be butt jointed providing the top layer joint is not directly on top of the bottom layers. This method will improve the look of the roof as there will be no ridges from overlapping.

Application

Stir the resin in its original container to ensure that any additives in the resin are thoroughly mixed in. Decant enough resin, into a separate container, to 'wet out' the fibreglass mat.

450g matting will require a minimum of 1.2kg resin per metre run.

600g matting will require a minimum of 1.5kg resin per metre run.

Mix the resin thoroughly with correct amount of catalyst. To start the process of laying up, firstly cover the area of board being fibreglassed with a coat of resin using a medium pile roller. Lay the fibreglass on the wet board and 'wet out' with the remaining resin, being careful to avoid leaving any dry patches in the fibreglass mat. Now use a consolidating roller to roller the area to remove any air bubbles and work the resin into the fibreglass mat until it is transparent.

If you are using a 2 layer system, lay the second layer of fibreglass mat onto the first original layer immediately after applying resin ('wet on wet') and before consolidating. Add more resin to ensure no dry patches and then consolidate.

Inspect the laminate, it should appear clear, ensure there are no dry patches (where matting appears white) or pin holes. If any are found add more resin to affected area and reconsolidate.

Step 5. Topcoating

Once the roof area has cured and is touch dry, the area can now be topcoated to create the final waterproof layer. Inspect fibreglass layer for signs of any defect such as loose strand spikes which should be sanded and then cleaned of dust. If fibreglass layer is older than 48 hrs the whole roof needs to be sanded with 40 grit paper and wiped down with acetone to ensure a suitable bond between topcoat and fibreglass.

Thoroughly mix the tin of topcoat to ensure that the wax additive and pigment are evenly distributed. Decant the topcoat into a separate container, into an amount that is manageable and mix thoroughly with the correct amount of catalyst.

Coverage of topcoat is approx 500g per m2 minimum.

Once catalysed, the top coat can be applied to the roof using a short pile roller. Ensure coverage is even and ensure the topcoat is completely covering the fibreglass with nothing exposed. Trims should also be topcoated. Cover the entire roof with the topcoat and allow to cure. If you are adding slate chippings, they can be now sprinkled on the wet topcoat. Always ensure that the area is kept dry whilst curing, as water can affect the appearance and strength of the uncured laminate.

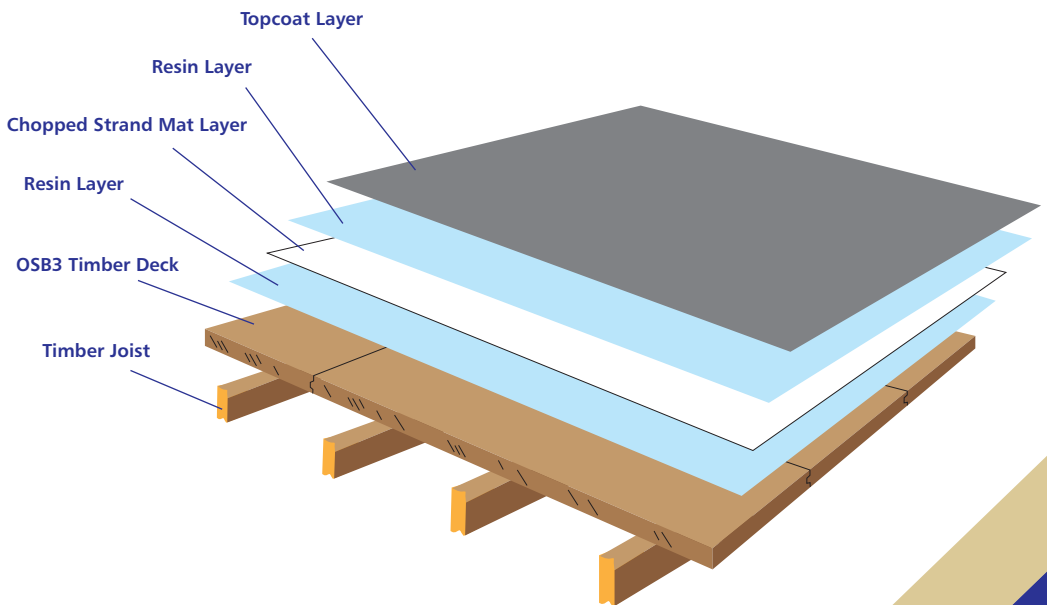

Working in hot conditions

Unfortunately at very high temperatures, especially under direct sunlight, the wax in the topcoat becomes more soluble and does not rise to the surface leading to an inhibited and poorly cured surface.

This under-cured area can remain tacky to the touch and when exposed to water leads to a white bloom.

If possible, use a temperature sensor to measure the surface temperature of the laminate before applying the topcoat. It is not recommended to apply topcoat on surfaces above 35°C.

Apply the topcoat out of direct sunlight or wait until the laminate and working conditions have cooled. To gain a good bond to the laminate the topcoat should be applied within 24 hours. If this is not possible the surface should be abraded with 100 grit sand paper then wiped with acetone before application.

Always use low activity catalyst in hot conditions. Stir topcoat well before use to ensure good mixing of topcoat, wax and styrene.

Using Cut Boards

Cut deck boards must have 3-5mm expansion gap between sheets. The joints need to be sealed with a strip of fibreglass tape or bandage. This would be done at step 3 part of the lay up process. (see inside).

Roofing over Bitumen

Unfortunately resin is prevented from curing by Bitumen. The Bitumen will have to be removed before lay up can begin. If it cannot be removed the deck will have to be replaced completely, or 6mm ply applied to cover the Bitumen. If this is not possible, the best alternative would be felt.

Health and Safety

The products can be harmful if ingested or in contact with skin. Take care when using these substances.

