

ELECTRAMATE 2000

DESIGN, INSTALLATION AND SERVICING INSTRUCTIONS

Gas Council Approved Reference Numbers

ElectraMate 270 97-317-36

ElectraMate 170 97-317-37



*The code of practice for the installation,
commissioning & servicing of central heating systems*

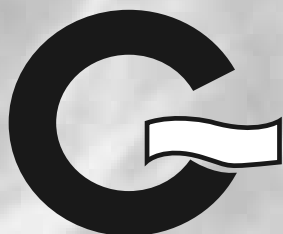

**A COMBINED PRIMARY STORAGE UNIT (CPSU) FOR
DOMESTIC HOT WATER SUPPLY AND CENTRAL
HEATING UTILISING OFF-PEAK ELECTRICITY**

**ALL MODELS COMPLY WITH THE
WATER HEATER MANUFACTURERS SPECIFICATION
FOR INTEGRATED THERMAL STORES**

CONTENTS

ISSUE 6 : 06-08

Section	Page
1.0 DESIGN	
1.1 Introduction	3
1.2 Technical Data	6
1.3 System Details	10
2.0 INSTALLATION	
2.1 Site Requirements	17
2.2 Installation	18
2.3 Commissioning	23
3.0 SERVICING	
3.1 Annual Servicing	27
3.2 Changing Components	27
3.3 Short Parts List	28
3.4 Fault Finding	30
Appendix A	33
Appendix B	34
Appendix C	37
Appendix D	38
Terms & Conditions	39



*The code of practice for the installation,
commissioning & servicing of central heating systems*

As part of the industry wide "Benchmark" Initiative all Gledhill ElectraMates now include a Benchmark Installation, Commissioning and Service Record Log Book. Please read carefully and complete all sections relevant to the appliance installation. The details of the Log Book will be required in the event of any warranty work being required. There is also a section to be completed after each regular service visit. **The completed Log Book and these instructions should be left in the pocket provided on the back of the front panel.**

WARNING : There are no user serviceable parts inside the appliance cover. All annual inspections and/or servicing must be carried out by suitably qualified and competent persons.

The Gledhill ElectraMate range is a WBS listed product and complies with the WMA Specification for integrated thermal storage products. The principle was developed in conjunction with British Gas. This product is manufactured under an ISO 9001:2000 Quality System audited by BSI.

Patents Pending

The Gledhill Group's first priority is to give a high quality service to our customers.

Quality is built into every Gledhill product and we hope you get satisfactory service from Gledhill.

If not please let us know.

1.0 DESIGN

1.1 INTRODUCTION

Any water distribution and central heating installation must comply with the relevant recommendations of the current version of the Regulations and British Standards listed below:-

Building Regulations
I.E.E. Requirements for Electrical Installations
- BS 7671 : 1992
Water Regulations

British Standards
BS6798, BS5449, BS5546, BS5440:1, BS5440:2,
CP331:3, BS6700, BS5258, BS7593 and BS7671.

Although the domestic water supply to the ElectraMate 2000 is at mains pressure, it is not necessary to fit an expansion vessel, pressure or temperature relief valve.

The ElectraMate 2000 is available for use with sealed primary central heating systems.

The manufacturers notes must not be taken as overriding statutory obligations.

The ElectraMate 2000 is not covered by section G3 of the current Building Regulations and is therefore not notifiable to Building Control.

The information in this manual is provided to assist generally in the selection of equipment. The responsibility for the selection and specification of the equipment must however remain that of the customer and any Designers or Consultants concerned with the design and installation.

Please Note: We do not therefore accept any responsibility for matters of design, selection or specification or for the effectiveness of an installation containing one of our products unless we have been specifically requested to do so.

All goods are sold subject to our Conditions of Sale, which are set out at the rear of this manual.

In the interest of continuously improving the ElectraMate range, Gledhill Water Storage Ltd reserve the right to modify the product without notice, and in these circumstances this document, which is accurate at the time of printing, should be disregarded. It will however be updated as soon as possible after the change has occurred.

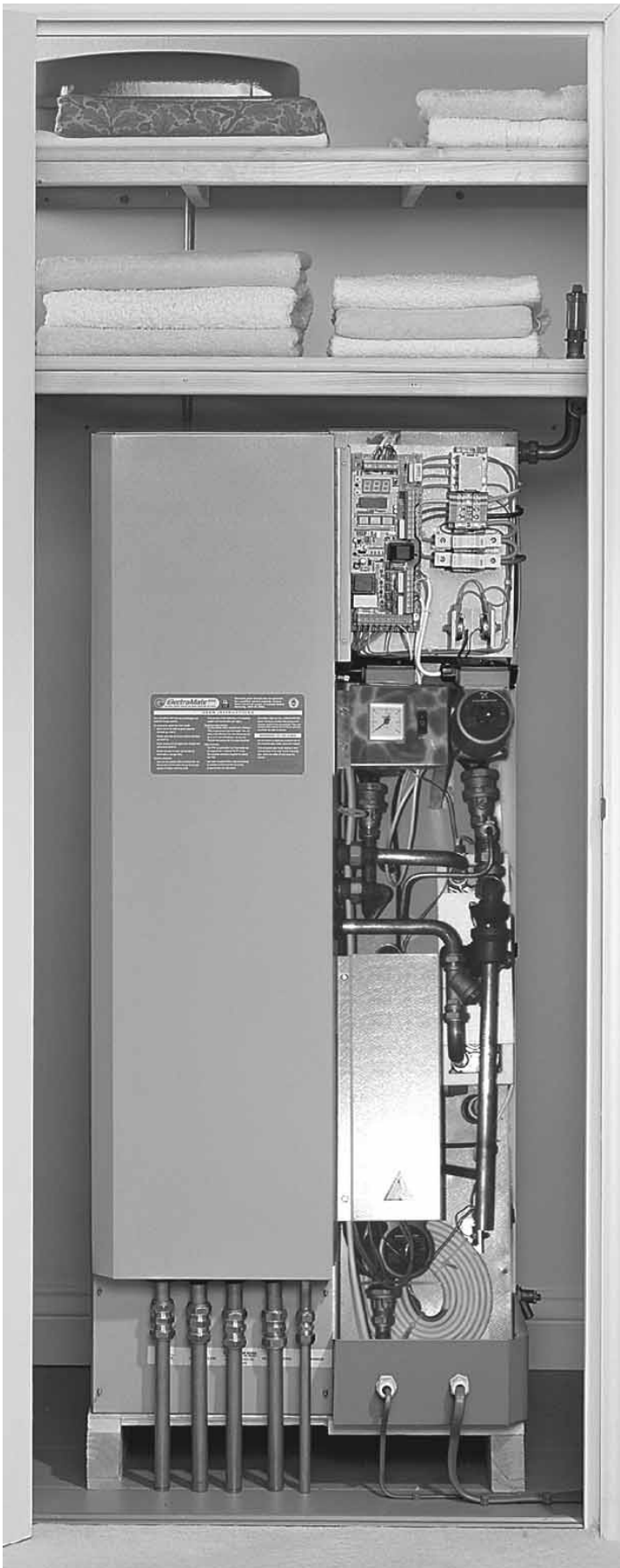

1.0 DESIGN

1.1 INTRODUCTION

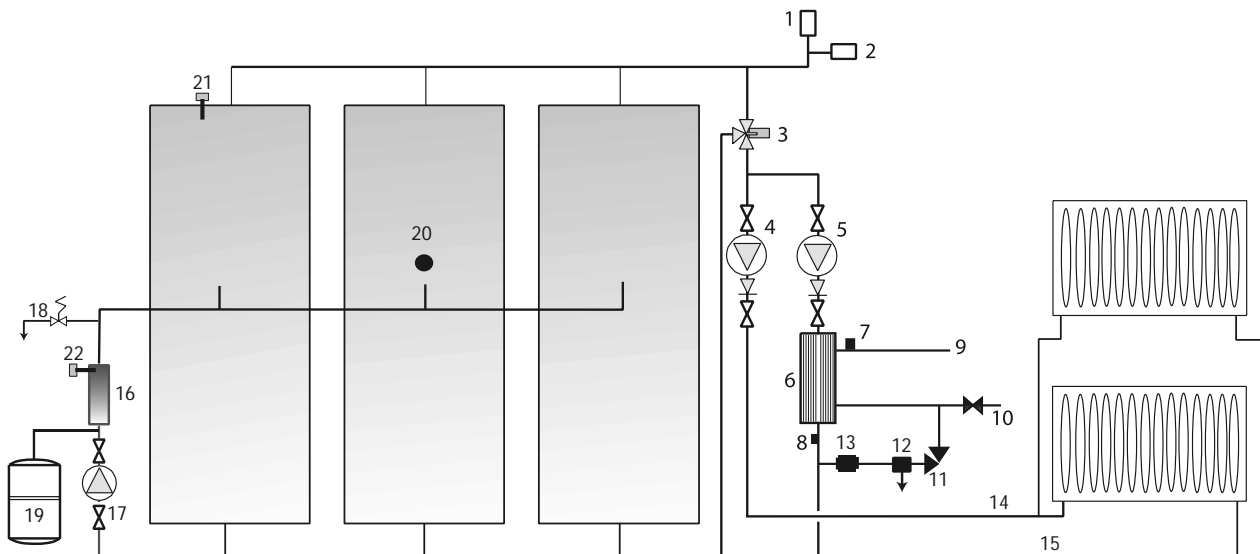

Key to Schematic

1. Automatic air vent
2. Anti-vacuum valve
3. Blending valve
4. Heating pump
5. PHE pump
6. Plate heat exchanger
7. DHW sensor
8. PHE return sensor
9. Hot water outlet
10. Mains cold water inlet
11. 90° angle isolating ballvalve
12. CA type backflow prevention valve - discharging into a tundish
13. Filling pressure regulating valve
14. Heating flow
15. Heating return
16. 9kW electric flow boiler
17. Boiler pump
18. Pressure relief valve - discharging into CA tundish pipe
19. Expansion vessel
20. Store temperature sensor
21. Store overhear thermostat
22. Electric boiler overhear thermostat

1.0 DESIGN

1.1 INTRODUCTION

The ElectraMate 2000 has been designed to utilize the latest technology to provide mains pressure hot water and traditional wet central heating from conventional radiators utilising off-peak electricity. Two sizes are available to suit different property types/sizes.

For optimum efficiency it is important that the best off-peak tariff is available, and a minimum of Economy 10 is recommended (see Model Selection Table below).

Note: The appliance will only operate cost effectively when supplied with an unrestricted 24 hour supply which uses a low current off peak signal synchronised with the off peak tariff periods (such as Economy 10).

The ElectraMate 2000 is controlled by a microprocessor based PCB and operates as follows.

Charging of the thermal stores

The electronic sensor monitors the store temperature and when the store is depleted the controller starts the recharge cycle giving priority to times when off-peak electricity is available. When the controls are enabled to recharge the store pump and heaters are switched on and these continue to run until the store sensor is satisfied i.e. fully charged.

The control system automatically selects the store charge temperature and control thermostat differential to match electricity tariffs. In the summer months there is no requirement for space heating therefore the occupant can lower the store charge temperature by means of the summer/winter switch which will reduce the runnings costs.

MODEL SELECTION TABLE		
Electricity Supply Tariff	Maximum design heat loss of dwelling (kW)	
	Model EM 270	Model EM 170
7h night time off-peak only (Economy 7)	4.0	2.5
10h off-peak (5 hour night time, 3 hour afternoon and 2 hour evening) (Economy 10)	6.0	3.5
18h+ off peak with not more than 2 hour interval between off-peak periods (Economy 18)	7.5	5.0
Property type		
* Number of bedrooms	1 - 3	1 - 2
* Number of bathrooms/shower rooms	1/2	1/1

In large properties with design heat losses greater than the above it is possible to use more than one appliance. However, in these situations the heating and hot water from each appliance **must** serve separate zones/bathrooms in the property which each fall within the above model selection criteria

Space Heating Operation

The operation of the space heating is controlled by user controls, a programmable room thermostat is provided loose for this purpose. When there is a demand for space heating from the programmable room thermostat the ElectraMate 2000 control system starts the space heating pump which circulates the preheated hot water from the stores to the radiators. The space heating pump continues to run as long as the heat demand signal is present from the user controls, other than when hot water is being drawn.

The self-acting 3-port mixing valve controls the space heating flow temperature to increase the utilisation of stored energy.

Domestic Hot Water Operation

An important feature of this concept is that hot water can be supplied directly from the mains at conventional flow rates without the need for temperature and pressure relief safety valves or expansion vessels. This is achieved by passing the mains water through a plate heat exchanger (PHE), which is heated instantaneously by the primary water circulated by the dedicated pump through the PHE.

The outlet temperature of the domestic hot water maintained at a pre-set level (normally about 50 - 55°C) by an electronic controller, which regulates the speed of the pump circulating the primary water from the store through the plate heat exchanger.

To comply with the Benchmark Guidance Note for Water Treatment in heating and hot water systems the installer should check the hardness levels of the water supply and if necessary fit an in-line scale inhibitor/reducer to provide protection to the whole of the domestic water system.

If scale should ever become a problem the plate heat exchanger is easily isolated and quickly replaced with a service exchange unit which can be obtained at a nominal cost from Gledhill. For further details see Section 1.3 Use in hard water areas page 12.

The self-acting 3 port mixing valve controls the flow temperature to the PHE at a pre-set value. This not only limits the maximum flow temperature to the PHE but it also increases the utilisation efficiency of the stored energy.

1.0 DESIGN

1.2 TECHNICAL DATA

MODEL		EM 270	EM 170
Primary store volume	litres	270	170
Weight * Empty * Full	(kg)	95 355	75 245
Maximum permitted static pressure * Thermal store * Heating circuit * Domestic hot water	(bar)	3.0 3.0 5.0	
Working pressure range * Thermal store * Heating circuit * Domestic hot water	(bar)	0.5 - 2.5 0.5 - 2.5 1.5 - 3.0	
Automatic Filling System	(bar)	1.5*	
Pressure relief valve - store and heating circuit		½" - factory set to operate at 3.0 bar	
Expansion vessel * Initial vessel charge pressure * Initial system charge pressure (recommended) * Expansion vessel volume * Expansion vessel size	(bar) (bar) (litres) (mm)	1.0 1.0 40 320 x 550	1.0 1.0 25 290 x 500
System design data * Store charge temperature * Heating circuit - flow * Heating circuit - return * Domestic hot water outlet * Initial heating system charge pressure * Normal heating system operating pressure * Maximum hot water flow rate	(°C) (°C) (°C) (°C) (bar) (bar) (l/min)	55-85 (Automatically selected by control system to match demand and electricity tariff) 82 71 (maximum) 55 (Non user adjustable) 1.0 1.0 - 2.5 35	
* Maximum design heating load (see Model Selection Table for further details)	(kW)	7.5	5.0
* Pumps (All) * Self acting 3-port blending valve * Store overheat thermostat * Electric boiler overheat thermostat * CA valve (part of auto top up device) * Pressure regulator (part of auto top up device) * Heater battery * Main PCB * Off-peak PCB		Grundfos UPS 15-50 Aquamix 61-CM-34H Gledhill GT 064 Gledhill GT 064 CA9C ½" Back flow preventer Alimat SK - AB2043 system fill unit factory set at 1.0 bar Gledhill 9kW inline heater Gledhill GT 155 Gledhill GT 159	
Pipe connections * Heating flow * Heating return * Hot water flow * Cold water mains supply * Discharge pipe (pressure relief) * Drain - store * Drain - heater battery * Discharge from tundish		22mm - copper 22mm - copper 22mm - copper 22mm - copper 15mm - copper into discharge pipe below tundish ½" ½" 22mm - copper	
Electricity Supply * kW Rating @ 230V * Nominal current @ 230V	(kW) (A)	9.5 (9.0kW heaters + 0.50kW auxillary circuit) 41.3	

- The flow rates quoted are based on a 35°C temperature rise and assumes the minimum recommended working pressure and adequate flow are available at the connection to the appliance.
 - The expansion vessel is separate from the appliance complete with a manual air vent/connector. This must be connected on site by the installer.
 - The domestic hot water outlet temperature is automatically regulated to approximately 55°C at the bath flow rate of 18 litres/min recommended by BS6700. The temperature is not user adjustable.
- * Minimum water supply pressure at the connection to the appliance under simultaneous demand conditions. (2.0 bar recommended)

1.0 DESIGN

1.2 TECHNICAL DATA

Standard Equipment

The standard configuration of the ElectraMate 2000 is shown opposite. The Appliance Control Board (A.C.B.), mounted inside the appliance, controls the operation of the complete system. It is supplied with the following factory fitted equipment:-

1. Automatic air vent
2. Anti-vacuum valve
3. Primary mixing valve
4. Heating pump
5. PHE pump
6. PHE
7. DHW sensor
8. PHE return sensor
9. Hot water outlet
10. Mains cold water inlet
11. 90° angle isolating ballvalve (key/screwdriver operated)
12. C A type backflow prevention valve - discharging into a tundish
13. Filling pressure regulating valve
14. Heating flow
15. Heating return
16. 9kW electric flow boiler
17. Boiler pump
18. Pressure relief valve - discharging into C A valve tundish
19. Expansion vessel
20. Store temperature sensor
21. Store overheat thermostat
22. Summer/winter switch
23. System pressure gauge
24. 3m x 10mm² electricity supply cable
25. Connection to expansion vessel
26. Danfoss TP5E Programmable Room Stat.
27. Boiler overheat thermostat
28. 100mm high installation pallet

Optional Equipment

- * Flexible connectors for quick connection to first fix pipe installation.
- * 2 x 20 litre expansion vessels

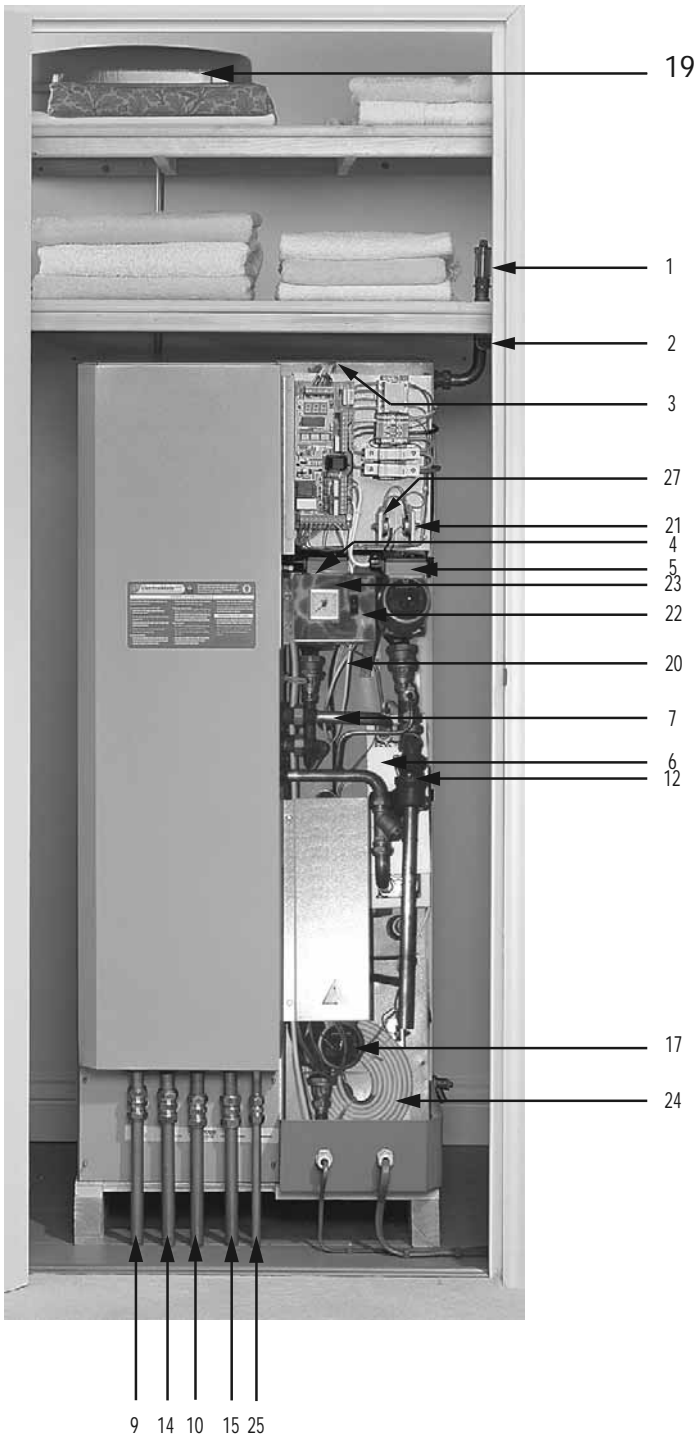

Illustration above is the model EM 170



27

1.0 DESIGN

1.2 TECHNICAL DATA

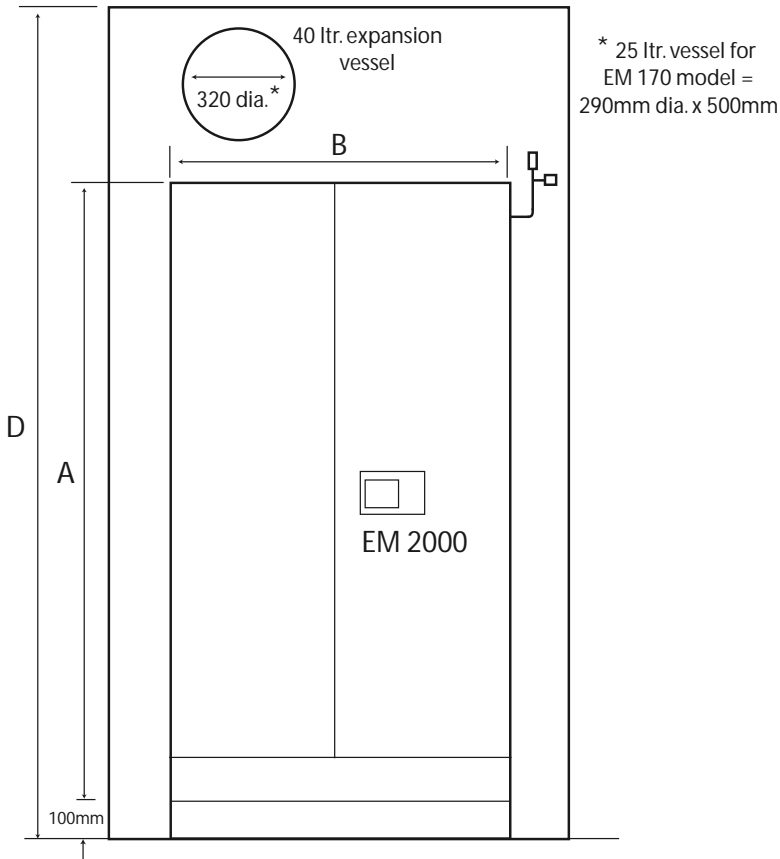

APPLIANCE DIMENSIONS			
Model	Height	Width	Depth
	A	B	C
EM 170	1350mm	595mm	595mm
EM 270	1910mm	595mm	595mm

The following table of minimum cupboard dimensions only allow the minimum space required for the appliance (including the expansion vessel) and any extra space required for shelving etc in the case of airing cupboards etc must be added.

If the expansion vessel is being fitted above the appliance it will need to be fitted first and access arrangements made for maintenance etc if the minimum cupboard dimensions are used.

MINIMUM CUPBOARD DIMENSIONS			
Model	Height	Width	Depth
	D	E	F
EM 170	1800mm	750mm	600mm
EM 270	2400mm	750mm	600mm

Note: The above cupboard height assumes the use of the installation pallet and the 40 litre expansion vessel.

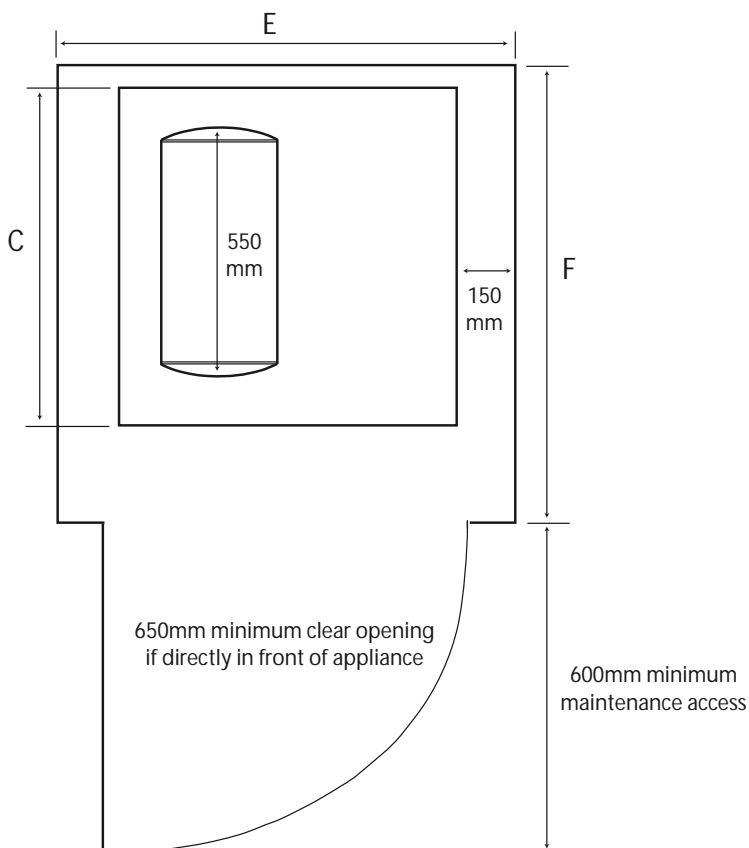

1.0 DESIGN

1.2 TECHNICAL DATA

It is easier if all pipes terminate vertically in the positions shown opposite. Compression or push fit connections can be used and we do offer a set of flexible connectors as an option. All pipe positions are approximate and subject to a tolerance of $\pm 10\text{mm}$ in any direction.

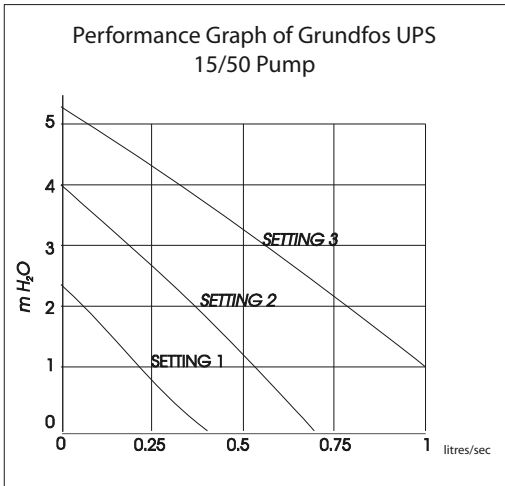
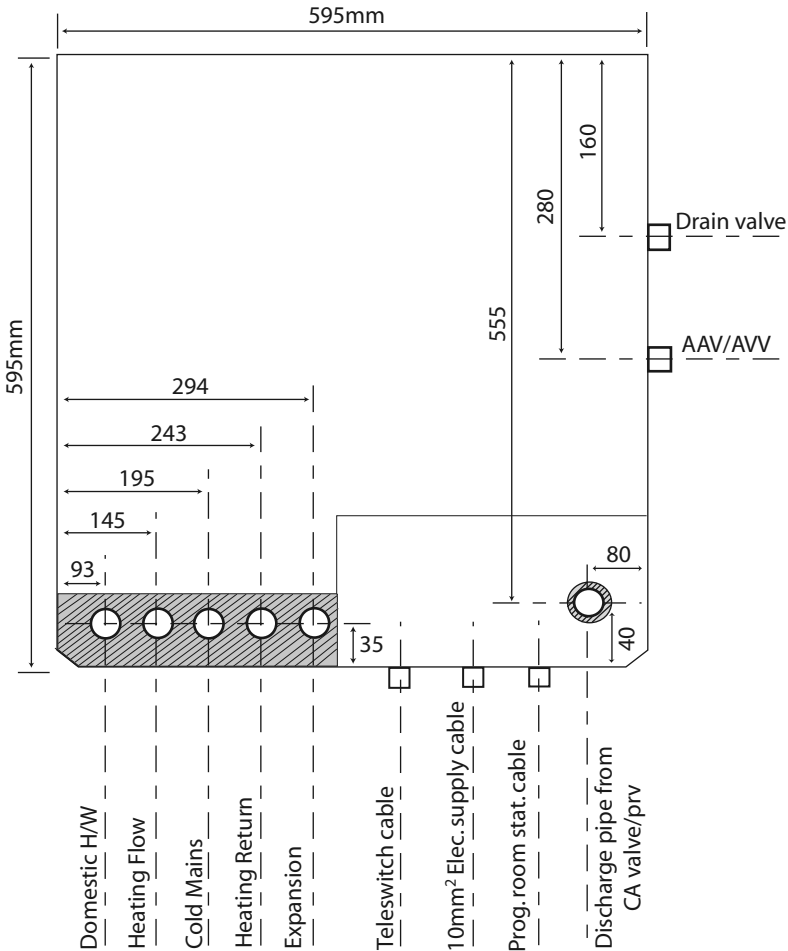

1.0 DESIGN

1.3 SYSTEM DETAILS

A schematic arrangement of the wiring in the ElectraMate is shown below.

To ensure efficient operation of the appliance it is important that discussions take place with the Electrical Supply Authority to ensure that the best off peak supply/tariff is utilized.

When designing the electrical system reference should be made to the latest issue of the IEE Requirements for Electrical Installations and the table on the next page to ensure that the electrical supplies are adequate and that the correct fusing/cable sizes are chosen.

This is particularly important in existing properties, especially if these are blocks of flats/apartments.

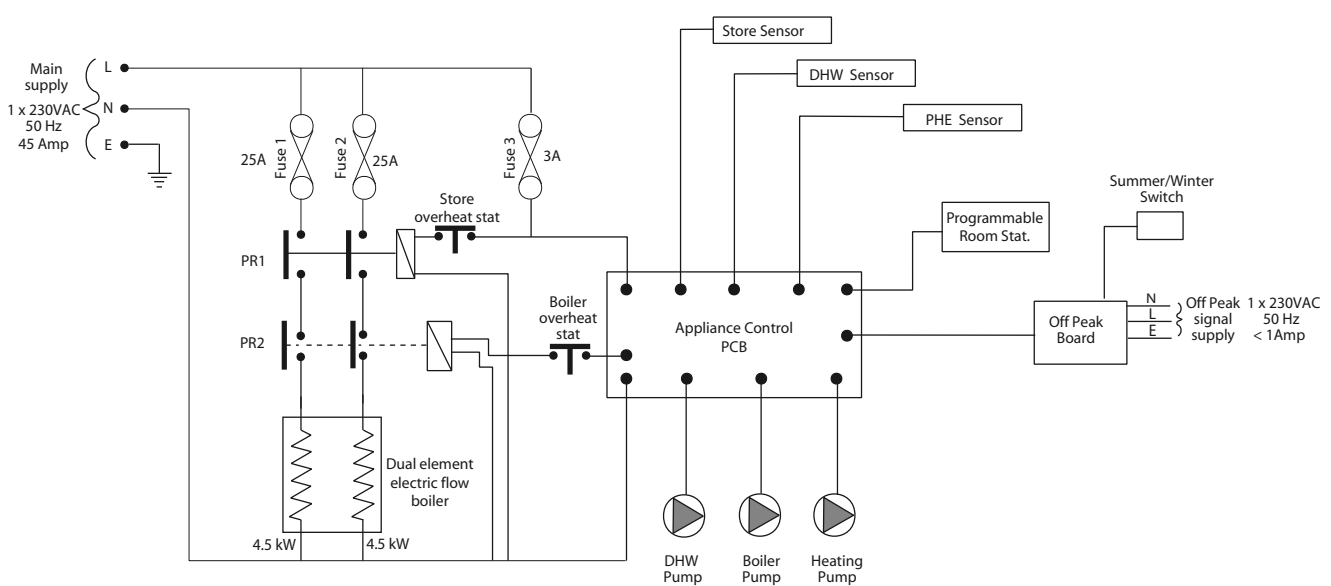

1.0 DESIGN

1.3 SYSTEM DETAILS

ElectraMate 2000 Wiring Guide

1. Appliance requires an unrestricted 24hr 45amp supply.
2. This Unit also requires a low current off peak signal synchronised with the low tariff (off peak) periods.
3. The diagram below showing the radio telemeter has two switched Live outputs.
4. The Domestic supply is fed via the permanent Live which is logged on tariff 1 on-peak and tariff 2 between off-peak periods.
5. The Tariff we recommend as a minimum is a new "Economy 10 Tariff E10" which has been approved by the Office of Gas and Electricity Markets (Ofgem) available October 2000.
The low rate will apply for a total of ten hours from:
 - 5 Hours - 00.00 to 05.00 GMT
 - 3 Hours - 13.00 to 16.00 GMT
 - 2 Hours - 20.00 to 22.00 GMT

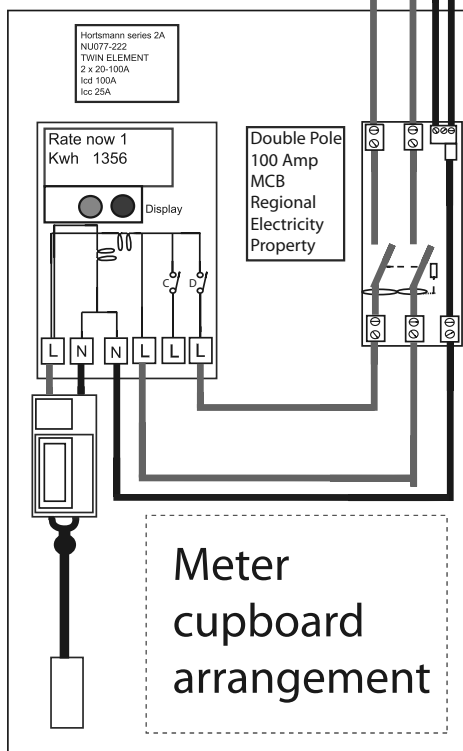
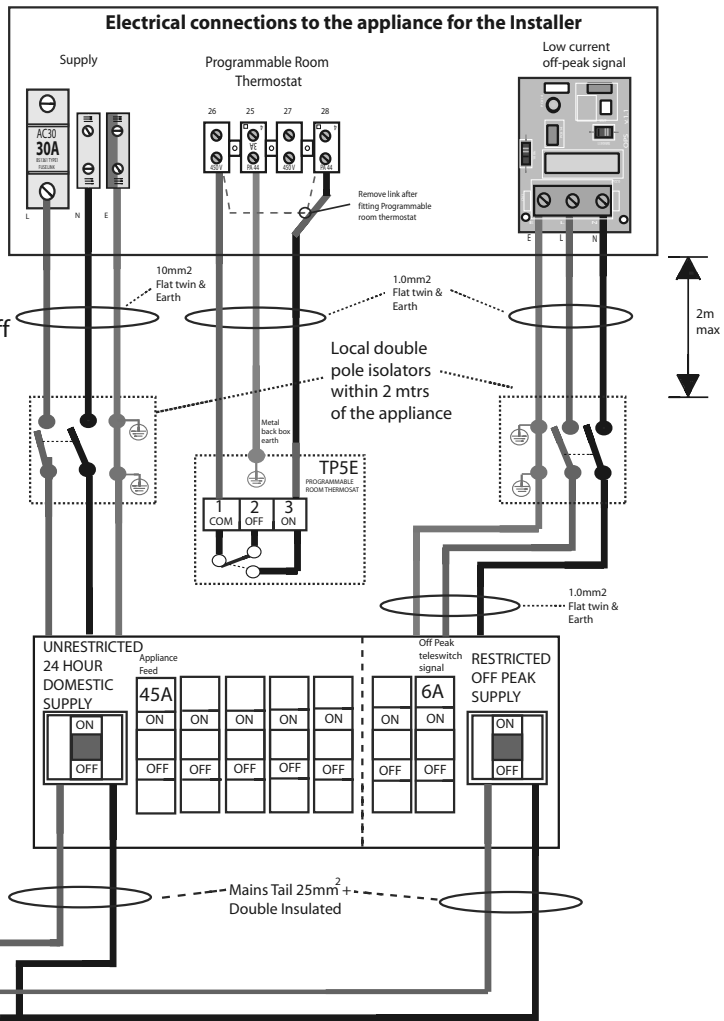

All Electrical work must comply with the IEE Requirements for Electrical Installations (BS 7671). It is the responsibility of the competent Electrical Installer to use the details below in conjunction with the latest British Standards

KW Rating @ 230V + 10% / -6%	Nominal current @ 230V (amps)	Min. Rating of Isolating switch @ 230 V (amps)	Max. Cable run based on a 9.2/Volt drop & earth fault loop impedance for 0.4s disconnection time. Also using type 1 or B Protection devices
9.0 KW Heating Load 500W Auxillary Load Pumps control circuit etc.	41.30 Amps	45 Amp	10mm ² 49 mtrs max
Low current signal supply	0.1 < Amp	2 Amp	1.0mm ² flat twin & earth 150 mts max
9.5 KW Thermal Storage Appliance recommended C.P.D (circuit protection device) to ensure a 0.4sec disconnection time under fault conditions.	45A type 1 mcb to 45A type B circuit breaker to 50 A mcb to 50A type B circuit breaker to	BS 3871 BS EN 60898 *** Provides best protection BS 3871 BS EN 60898	

Note : Before carrying out any work on the appliance ensure that BOTH independant electrical supplies are isolated.

1.0 DESIGN

1.3 SYSTEM DETAILS

Hot and Cold Water System

General

A schematic layout of the hot and cold water services in a typical small dwelling is shown below. ElectraMate 2000 will operate at mains pressures as low as 1.5 bar and as high as 5 bar although the recommended range is 2-3 bar. All pressures must be achievable when the local demand is at its maximum and be measured at the connection to the appliance. It is also important to check that all other equipment and components in the hot and cold water system are capable of accepting the mains pressure available to the property. If the mains pressure can rise above 5 bar or the maximum working pressure of any item of equipment or component to be fitted in the system, a pressure limiting (reducing) valve set to 3 bar will be required.

No check valve or similar device should be fitted on the cold water supply branch to the ElectraMate 2000.

The hot water flow rate from the ElectraMate 2000 is directly related to the adequacy of the cold water supply to the dwelling. This must be capable of providing for those services, which could be required to be supplied simultaneously, and this maximum demand should be calculated using procedures defined in BS 6700.

If a water meter is fitted in the service pipe, it should have a nominal rating to match the maximum hot and cold water peak demands calculated above in accordance with BS 6700. This could be up to 50ltr/min in some properties.

Use in Hard Water Areas

The patented control system offers a sophisticated level of pump speed control and will help prevent the formation of scale. This prevents domestic hot water from exceeding 55°C for most of the operational times of the appliance.

The pre-set temperature of approximately 55°C is not adjustable.

To comply with the Benchmark Guidance Note for Water Treatment in Heating and Hot Water Systems the installer should check the hardness level of the water supply and if necessary fit an in-line scale inhibitor/reducer to provide protection to the whole of the domestic water system. See Appendix C for a copy of the relevant part of the Benchmark Guidance Note.

When specifying this appliance we would recommend that for hardness levels above 280ppm (mg/l) advice is obtained on the type of in-line scale inhibitor/reducer to be used from one of the Water Treatment companies listed in the Benchmark Guidance Note (see Appendix C).

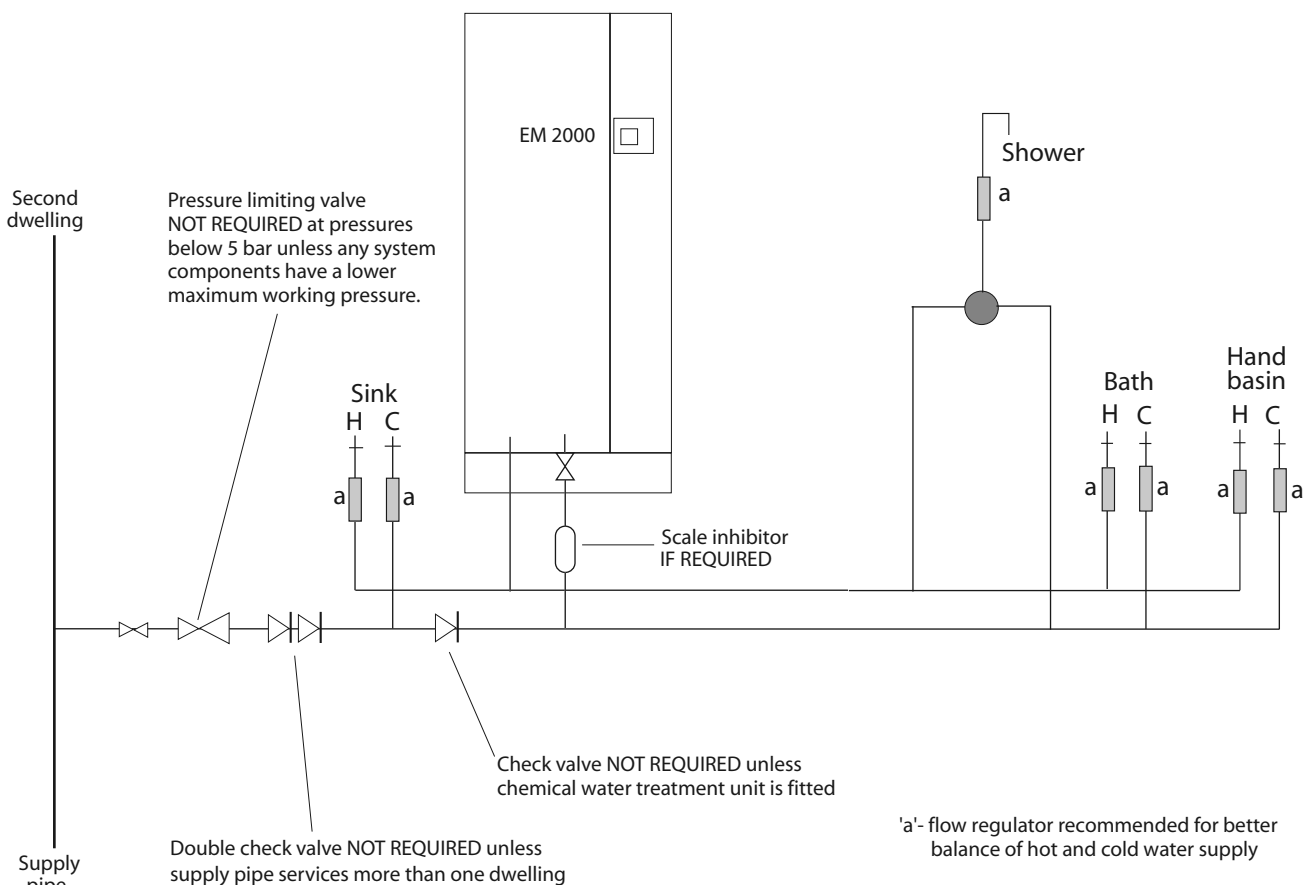

Typical hot and cold water distribution

1.3 SYSTEM DETAILS

Hot and Cold Water System

Pipe Sizing / Materials

To achieve even distribution of the available supply of hot and cold water, it is important in any mains pressure system, that the piping in a dwelling should be sized in accordance with BS 6700.

However, the following rule of thumb guide lines should be adequate for most smaller property types as long as water pressures are within the recommended range of 2-3 bar.

1. A 15mm copper or equivalent external service may be sufficient for a small 1bathroom dwelling (depending upon the flow rate available), but the minimum recommended size for new dwellings is 22mm (25mm MDPE).
2. The internal cold feed from the main incoming stop tap to the ElectraMate should be run in 22mm pipe. The cold main and hot draw-off should also be run in 22mm as far as the branch to the bath tap.
3. The final branches to the hand basins and sinks should be in 10mm and to the baths and showers in 15mm. (1 metre minimum)
4. **We would recommend that best results for a balanced system are achieved by fitting appropriate flow regulators to each hot and cold outlet. This is particularly relevant where the water pressures are above the recommended water pressure range of 2-3 bar. (See Appendix 1 for further details.**

Note: If manifolds (available as an optional extra) are being used suitable flow regulators are automatically provided in the manifold and do not need to be provided at each outlet - See Appendix B for further details.

All the recommendations with regard to pipework systems in this manual are generally based on the use of BS/EN Standard copper pipework and fittings.

However, we are happy that plastic pipework systems can be used in place of copper internally as long as the chosen system is recommended for use on domestic hot and cold water systems by the manufacturer and is installed fully in accordance with their recommendations.

This is particularly important in relation to use of push fit connections when using the optional flexible hose kits - see 2.2 Installation, Pipework connections.

It is also essential that if an alternative pipework material/system is chosen the manufacturer confirms that the design criteria of the new system is at least equivalent to the use of BS/EN Standard copper pipework and fittings.

Taps/Shower Fittings

Aerated taps are recommended to prevent splashing.

Any type of shower mixing valve can be used as long as both the hot and cold supplies are mains fed. However, all mains pressure systems are subject to dynamic changes particularly when other hot and cold taps/showers are opened and closed, which will cause changes in the water temperature at mixed water outlets such as showers. For this reason and because these are now no more expensive than a manual shower we only recommend the use of thermostatic showers with this appliance, even if these are the over the bath/telephone handset type.

The shower head provided must also be suitable for mains pressure supplies.

The hot water supply to a shower-mixing valve should be fed wherever practical directly from the ElectraMate 2000 or be the first draw-off point on the hot circuit. The cold supply to a shower-mixing valve should wherever practical be fed directly from the rising mains via an independent branch. The shower must incorporate or be fitted with the necessary check valves to provide back-siphonage protection in accordance with the Water Regulations.

The supply of hot and cold mains water directly to a bidet is permitted provided that it is of the over-rim flushing type and that a type 'A' air gap is incorporated.

Hot and Cold Water System

If the length of the hot water draw off pipework is excessive and the delivery time will be more than 30 seconds before hot water is available at the tap, you may wish to consider using trace heating to the hot water pipework such as the Raychem HWAT system. Please consult Gledhill Technical Department for further details.

Please note that the ElectraMate 2000 is NOT suitable for use with a secondary domestic hot water circulation system.

It is important that the cold water pipework is adequately separated/protected from any heating/hot water pipework to ensure that the water remains cold and of drinking water quality.

1.0 DESIGN

1.3 SYSTEM DETAILS

Heating System

General

A schematic layout of the heating system in a typical small dwelling is shown opposite.

The heating circuit is taken from the ElectraMate 2000 and is piped in the conventional manner.

The ElectraMate 2000 is only suitable for a **sealed heating** system. Therefore heating circuit pipework can run at a higher level than the appliance if required as long as suitable air vents are provided.

If any radiators are located above the level of the ElectraMate 2000 the system should be designed so that gravity circulation does not occur when the heating pump is not running. To be certain of preventing this it is recommended that a check valve, or valves, are fitted on the vertical flow pipes.

The heating circuit operates on the normal primary boiler temperatures i.e. 82°C flow and 71°C return. Therefore any traditional hot water radiators or convectors can be used with this system and it is recommended that they are sized in accordance with BS EN 442.

The Grundfos 15/50 pump characteristics are shown in 1.2 Technical Data. Approximately all the head can be used when sizing the heating circuit pipework.

All the recommendations with regard to pipework systems in this manual are generally based on the use of BS/EN Standard copper pipework and fittings.

However, we are happy that plastic pipework systems can be used in place of copper internally as long as the chosen system is recommended for use on domestic heating systems by the manufacturer and is installed fully in accordance with their recommendations. We always recommend the use of barrier pipe for these systems.

It is also essential that if an alternative pipework material/system is chosen the manufacturer confirms that the design criteria of the new system is at least equivalent to the use of BS/EN Standard copper pipework and fittings.

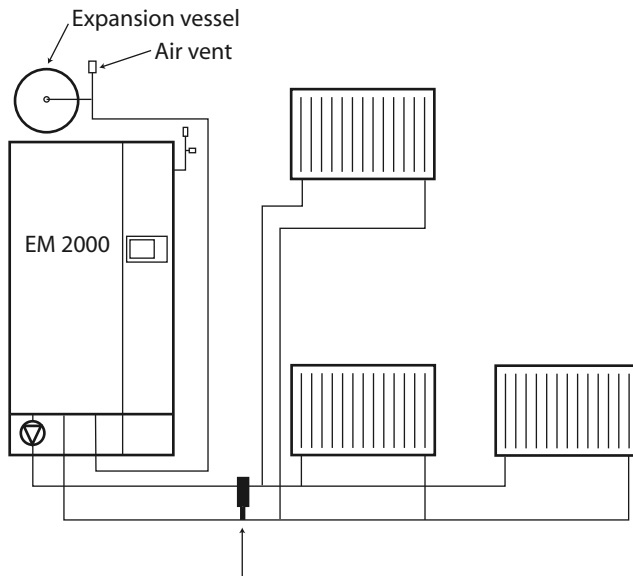

Full bore auto bypass valve NOT REQUIRED unless the heating system incorporates mechanical thermostatic control valves e.g. T.R.V's to all radiators or 2 port zone valves. As an alternative one of the radiators can be fitted with lockshield valves which are left fully open, permanently.

1.0 DESIGN

1.3 SYSTEM DETAILS

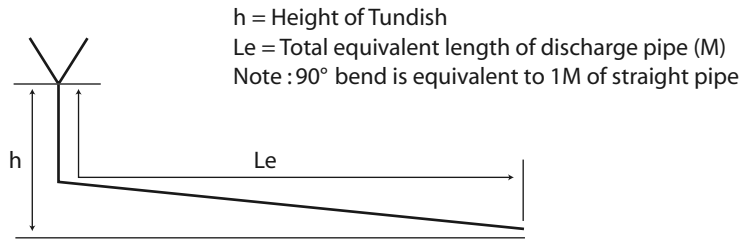

DISCHARGE PIPE DIAMETERS

Height - h (M)	Pipe Size	Maximum Le (M)
0.2	15mm	1
	22mm	9
	28mm	30
0.3	15mm	2
	22mm	13
	28mm	45
0.4	15mm	3
	22mm	19
	28mm	63
0.6	15mm	4
	22mm	27
	28mm	94
0.8	22mm	5
	22mm	37
	28mm	127
1	15mm	7
	22mm	46
	28mm	157

Filling the Heating System

The ElectraMate 2000 appliance comes complete with a CA type backflow prevention valve and pressure regulating valve to provide automatic filling of the appliance/sealed heating system from the mains cold water connection to the appliance.

This is now allowed by the Water Regulations to stop any possible contamination of the mains cold water supply by the water in the heating system.

This replaces the temporary filling loop arrangement historically required by the Water Byelaws and means the connection to the mains cold water supply can be permanent. This will allow any loss of water from the heating system to be automatically replenished as with an open vented system fitted with a feed and expansion cistern.

Details of the valve and the discharge requirements are shown opposite. A 22mm minimum diameter discharge pipe is required.

The construction of the valve is such that the mains cold water cannot discharge through the tundish even when the mains side check valve is faulty. This is because the sliding piston, which opens the main port also closes the vent (i.e. tundish) port. The valve will therefore only discharge if the check valve on the appliance/system side is faulty and the mains pressure is less than the pressure in the appliance/system.

The valve requires a pressure differential to operate correctly and a minimum dynamic pressure of 1.5 bar is required at the connection to the appliance under maximum domestic water simultaneous demand conditions, 2.0 bar is recommended.

The pressure regulating valve is set to 1.0 bar. This is usually sufficient for the heating systems in most domestic properties - see the next page for further details.

Note: Do not open the 90° angle isolating ballvalve to fill the appliance/heating system until the heating system is complete - see the labels on the appliance for further details.

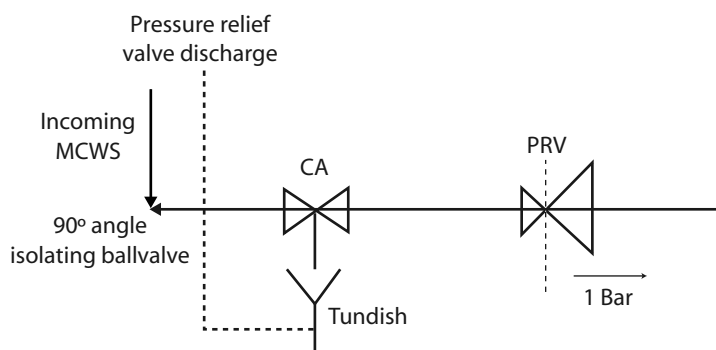

1.0 DESIGN

1.3 SYSTEM DETAILS

Expansion vessel requirements

The ElectraMate 2000 Model EM270 is supplied with a 40 litre expansion vessel and the model EM170 is supplied with a 25 litre expansion vessel. Both are supplied pre-charged to 1.0 bar to accommodate the expansion of total water content of the system including thermal store. The size of the expansion vessel provided with each model is considered adequate for a typical installation. However it is the designers/installers responsibility to check this and provide an additional expansion vessel if necessary.

The values presented in the table opposite are based on a maximum store charge temperature of 85°C. The expansion vessel must be suitable to accommodate the change in volume of the water in the primary system from 10°C to 110°C as specified in BS 5449 : 1990 clause 16.2.

In normal circumstances an initial system charge pressure of 1.0 bar is suitable for most domestic installations.

The minimum system pressure (when cold) should not be less than the static head plus 0.5 bar i.e. the height of the highest point in the system above the expansion vessel plus a safety margin of 0.5 bar. If a different system pressure is required than 1.0 bar the initial vessel charge pressure must be adjusted to the same value.

If an additional expansion vessel is required, this must comply with BS 4814 and must be suitable for heating circuit temperatures up to 110°C.

The expansion vessel's must be sized to accommodate the expansion of the total water content of the system i.e. heating circuit plus ElectraMate 2000 unit. Total expansion vessel volume required for different operating pressures and radiator circuit volumes is shown in the table opposite. The sizing procedure is outlined in BS 5449 : 1990.

Note : There must be no isolating valve between the expansion vessel(s) and the appliance or any other such device.

Expansion vessel volume required for different operating conditions				
Safety valve setting (bar)		3.0		
Vessel charge pressure (bar)		0.5	1.0	
Initial system pressure (bar)		0.5	1.0	1.0
Radiator circuit volumes (litres)	Total system volume (litres)	Expansion vessel volume (litres)		
15	285/185	23.7	39.9	31.1
20	290/190	24.2	40.6	31.6
25	295/195	24.6	41.3	32.2
30	300/200	25.0	42.0	32.7
35	305/205	25.4	42.7	33.2

2.0 INSTALLATION

2.1 SITE REQUIREMENTS

The appliance is designed to be installed in an airing/cylinder cupboard and the relevant minimum dimensions are provided in section 1.2 Technical Data.

Because of the ease of installation we recommend that the cupboard construction is completed and painted before installation of the appliance. The cupboard door can be fitted after installation.

If the unit needs to be stored prior to installation it should be stored upright in a dry environment and on a level base/floor.

Installation and maintenance access is needed to the front of the appliance and the separate expansion vessel. See Technical Data section for further details.

The minimum dimensions contained in section 1.2 Technical Data allow for the passage/connection of pipes to the appliance from any direction as long as the appliance is installed on the installation base provided. If the installation base is not used extra space may be needed to allow connection to the pipework and the whole of the base area should be continuously supported on a material which will not easily deteriorate if exposed to moisture.

The floor of the cupboard needs to be level and even and capable of supporting the weight of the appliance when full. If the ElectraMate 2000 is located on a platform above the floor this must provide continuous support to the whole back area and be made of a material which will not deteriorate if exposed to moisture. Details of the weight when full is provided in section 1.2 Technical Data.

The appliance is designed to operate as quietly as practicable. However, some noise (from pumps etc) is inevitable in any heating system. This will be most noticeable in cupboards formed on bulkheads, or at the mid span of a suspended floor. In these cases the situation can be improved by placing the appliance on a suitable sound deadening material (i.e. carpet underlay or similar).

Cupboard temperatures will normally be higher than in a conventional system and the design of the cupboard and door will need to take this into account. No ventilation is normally required to the cupboard.

A suitable location will be needed for the separate expansion vessel. This will often be at high level in the cupboard housing the ElectraMate 2000 but can be at a remote position if required. The dimensions and clearances are provided in section 1.2 Technical Data. The location will need to provide a suitable route for the expansion pipe from the vessel to the appliance.

An electrical supply must be available which is correctly earthed, polarized and in accordance with the latest edition of the IEE requirements for electrical Installations BS 7671.

The electrical mains supply needs to be 230V/50Hz.

Connections must be made using suitable double-pole linked isolator switches which are located within 2m of the appliance. The supplies must only serve the appliance.

The minimum breaking capacity of the main isolation switch and cable sizes/lengths at 230V shall follow the recommendations in the table below.

The low current signal supply cable should be 1.0mm² flat twin and earth terminating in a suitable isolator switch fused at 2 amps.

The location of the appliance will need to provide a suitable route and termination point for the discharge pipe from the CA Valve/PRV.

All Electrical work must comply with the IEE Requirements for Electrical Installations (BS 7671). It is the responsibility of the competent Electrical Installer to use the details below in conjunction with the latest British Standards			
kW Rating @ 230V + 10% / -6%	Nominal current @ 230V (amps)	Min. Rating of Isolating switch @ 230 V (amps)	Max. Cable run based on a 9.2Volt drop & earth fault loop impedance for 0.4s disconnection time, Also using type 1 or B Protection devices
9.0 kW Heating Load 500W Auxiliary Load Pumps control circuit etc.	41.30 Amps	45 Amp	10mm ²
			49M max
Low current signal supply	0.1 < Amp	2 Amp	1.0mm ² flat twin & earth 150M max
9.5 KW Thermal Storage Appliance recommended C.P.D (circuit protection device) to ensure a 0.4sec disconnection time under fault conditions.	45A type 1 mcb to 45A type B circuit breaker to 50 A mcb to 50A type B circuit breaker to	BS 3871 BS EN 60898 *** Provides best protection BS 3871 BS EN 60898	

2.2 INSTALLATION

Preparation/placing the appliance in position.

Details of the recommended positions for termination of the first fix pipework are provided in section 1.2 Technical Data. The pipework can be located or its position checked using the template provided with each appliance. If these have been followed installation is very simple and much quicker than any other system.

The appliance is supplied shrink wrapped and carrying handles are provided in the back of the casing.

The expansion vessel complete with inlet pipe and air vent are provided in a separate box. If flexible connections have been ordered these will be supplied in the same box as the expansion vessel.

The appliance should be handled carefully to avoid damage and the recommended method for the EM170 model is shown opposite.

Whenever it is possible it is recommended that the EM270 is moved using a suitable sack type truck on the rear face.

Before installation the site requirements should be checked and confirmed as acceptable. The bottom part of the plastic cover /protective wrapping should be removed and the appliance placed in position.

Remove the front panel by loosening the retaining screws 3-4 turns and lifting the panel up and out using the keyholes provided. Pull the pipe cover off (see opposite) ready for connection of the pipework and electrical supplies. Ensure both panels are replaced on completion and the retaining screws are tightened to secure the main panel back in position.

The expansion vessel shall be installed using the supports provided. Ensure access is provided for maintenance.

Note: Although the above guidance is provided any manual handling/lifting operations will need to comply with the requirements of the Manual Handling Operations Regulations issued by the H.S.E.

The appliance can be moved using a sack truck on the rear face although care should be taken and the route should be even.

In apartment buildings containing a number of storeys we would recommend that the appliances are moved vertically in a mechanical lift.

If it is proposed to use a crane expert advice should be obtained regarding the need for slings, lifting beams etc.

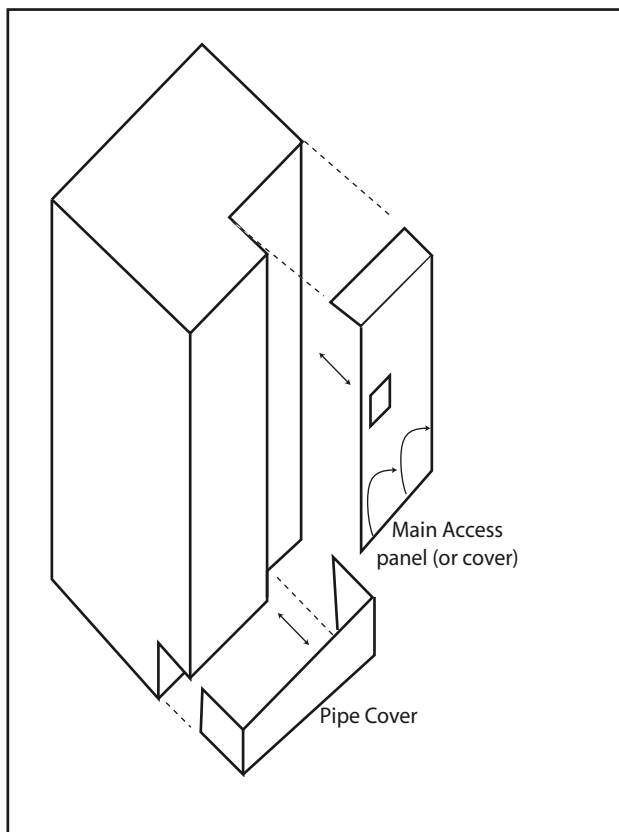
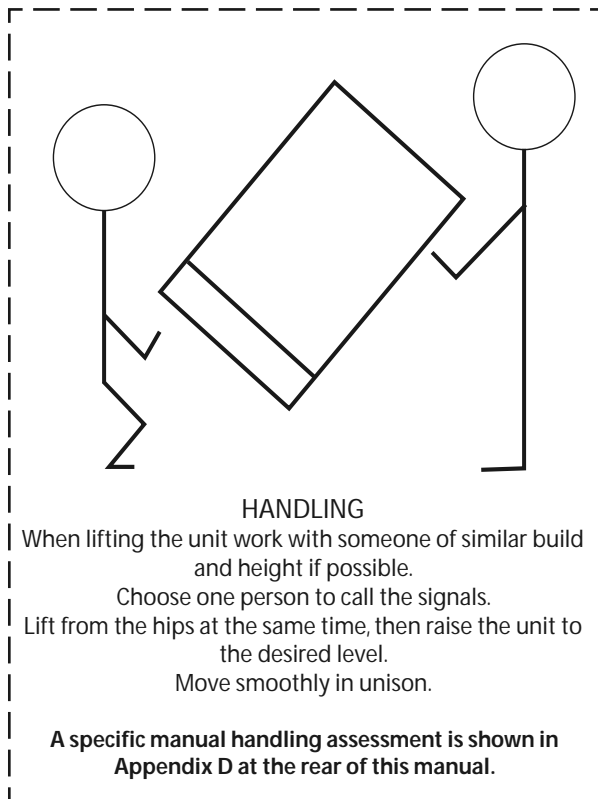

2.2 INSTALLATION

Pipework connections

The position of the pipework connections is shown opposite. The connection sizes and dimensions are listed in Section 1.2 Technical Data.

All the connections are also labelled on the appliance. It is essential that the pipework is connected to the correct connection.

The connections can be hard piped but we recommend the use of flexible connections (available as an optional extra).

Connections A, B, C, D, E and F are plain ended copper pipe.

Connection G is a compression fitting.

Connection H is RC $\frac{1}{2}$ ($\frac{1}{2}$ in BSPT internal).

- A - Domestic Hot Water
- B - Central Heating Flow
- C - Incoming Mains Cold Water
- D - Central Heating Return
- E - Expansion Pipe
- F - CA Valve/PRV Discharge Pipe
- G - AAV/AVV Assembly
- H - Drain Valve **NOT provided with the appliance).**

All factory made joints should be checked after installation in case they have been loosened during transit.

The expansion pipe should be run from the appliance and connected to the inlet pipe/air vent provided with the expansion vessel.

There must be no isolating valve between the expansion vessel(s) and the appliance.

Run the discharge pipe from the CA Valve/PRV to a position where the termination is visible and will not cause danger to persons or damage to materials - see 1.3 System Details for further information.

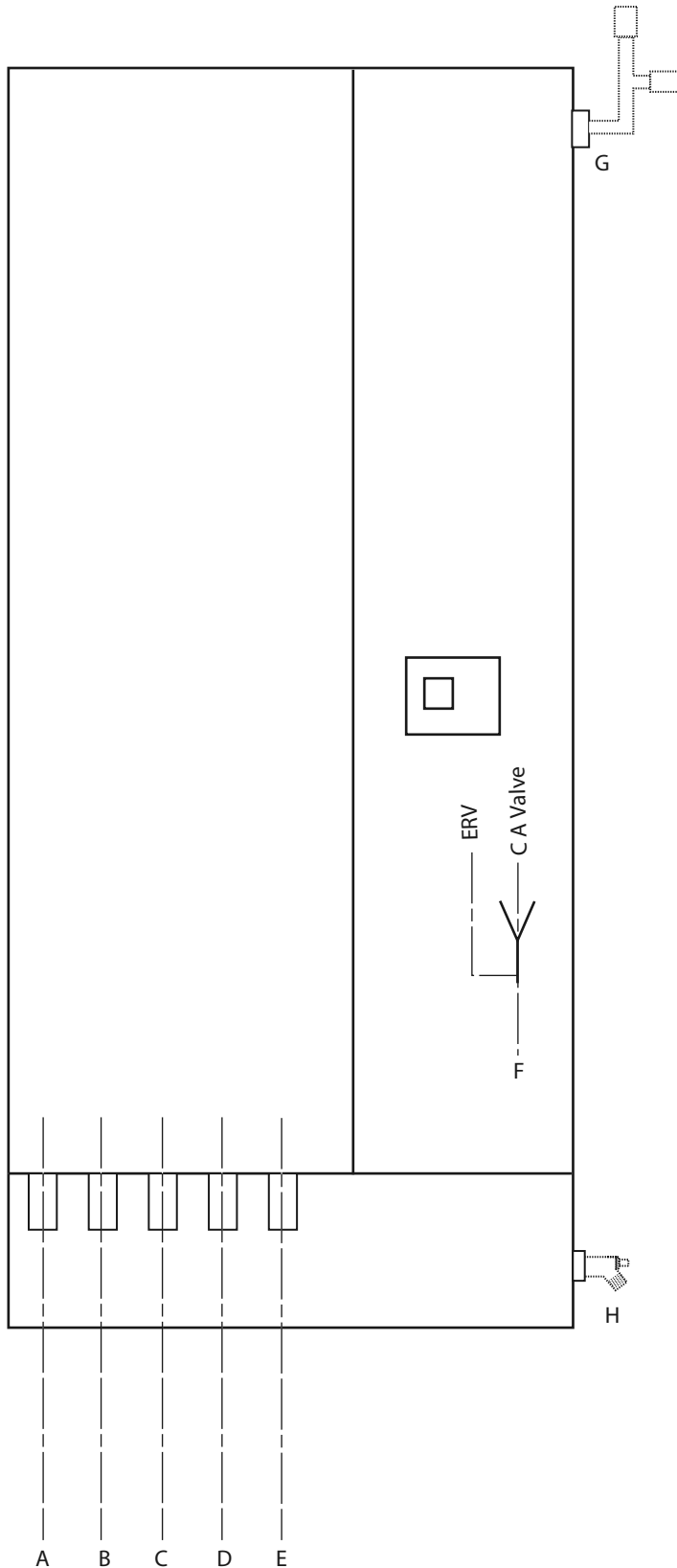

2.0 INSTALLATION

2.2 INSTALLATION

ElectraMate²⁰⁰⁰ Wiring Diagram

Wiring Key

R	Red
BR	Brown
BL	Blue
GY	Green/Yellow
BLK	Black

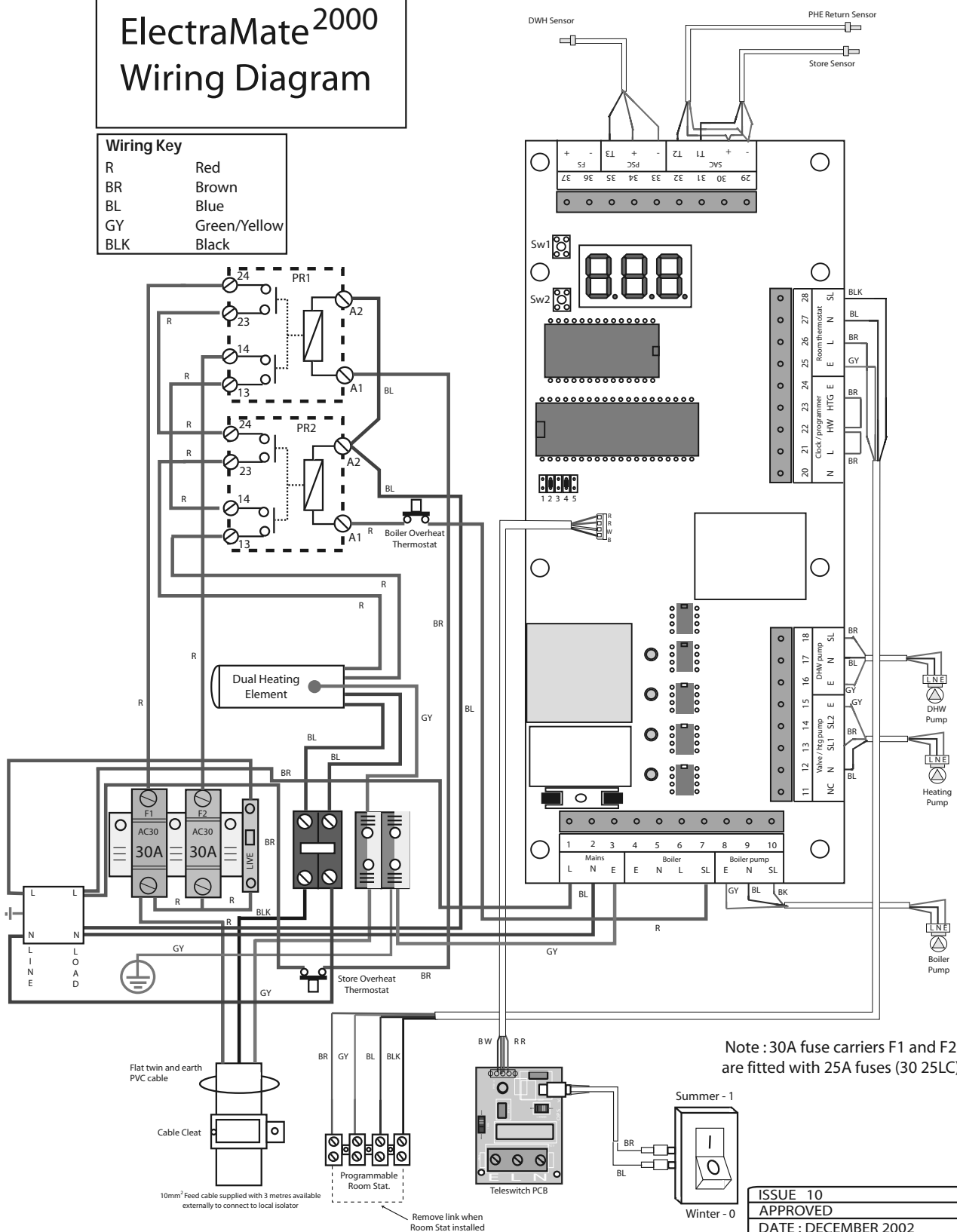

ISSUE 10
APPROVED
DATE : DECEMBER 2002

2.2 INSTALLATION

Wiring the System

A printed circuit board (ACB) controls the complete system and all the internal components are prewired to this board, as shown on the Appliance Wiring Diagram on the previous page.

The details of the arrangement and requirements for the external wiring are shown on the Wiring Guide Diagram in Section 1.3 System Details and Section 2.1 Site Requirements. Check the supplies comply with their requirements.

As shown opposite, a heavy duty electricity supply is required for the ElectraMate 2000 and therefore a **qualified electrician** must carry out this work. The electrical installation must comply with the IEE requirements for electrical installations (BS7671) and the requirements of the Local Electricity Supply Company.

All the terminals are suitably labelled.

Note : Do not attempt the electrical work unless you are competent to carry it out to the above standards.

Connections to the electrical supplies must allow complete electrical isolation by installing double pole isolators.

The isolators must only serve the ElectraMate 2000 space heating and hot water system together with its controls.

The use of Type 'B' circuit breakers to BS EN 60898 is recommended.

Before commencing the wiring, ensure that the power source to which the ElectraMate 2000 is to be connected is isolated and checked with approved and certified test equipment.

Remove the front panel.

The appliance is supplied with a 3 metre x 10mm² mains supply cable and a 3 metre x 1.0mm² low current off-peak signal cable which should be connected via the slot/grommets provided at low level on the appliance to the relevant local isolators provided as shown opposite.

To wire the **Programmable room thermostat :**

Remove the link between terminals 26 and 28 on the terminal block (see opposite)

From terminal 26 take a 'live' to the 'live common' on the programmable room t/stat. From the programmable room t/stat '3 N/O' connection take a 'switched live' to terminal 28. Connect one end of your earth cable to terminal 25 at the appliance and connect the other end of your earth cable to the earth terminal on the programmable room t/stat metal back box.

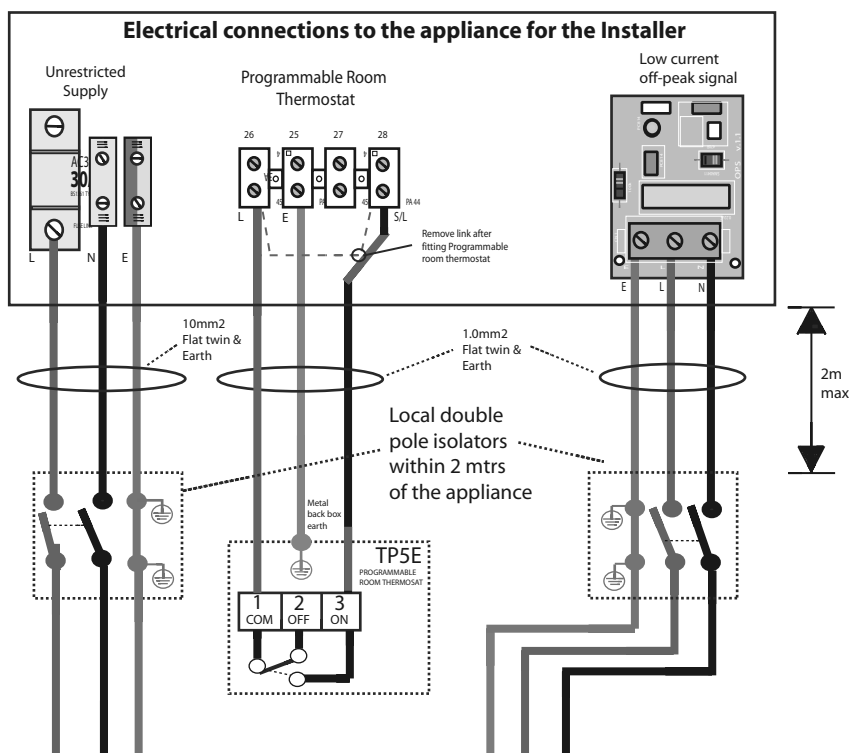

1. Appliance requires an unrestricted 24hr 45amp supply.
2. This unit also requires a low current off peak signal synchronised with the low tariff (off-peak) periods.
3. The diagram above shows the radio telemeter with two switched live outputs.
4. The domestic supply is fed via the permanent live which is logged on tariff 1 on-peak and tariff 2 off-peak periods.

2.0 INSTALLATION

2.2 INSTALLATION

Wiring the system (contd.)

Before switching on the electrical supply check all the factory made terminal connections to ensure they have not become loose during transit.

Note : The appliance is provided with a 4.0mm earth cable from an earthing strap on the primary return (to boiler) pipe to the earth stud on the wiring panel.

WARNING - When the wiring is complete but before switching on the appliance electrically ensure the unit is full of water by checking the air vent on the side of the appliance and ensuring the pressure gauge reads between 0.5 - 1.0 bar. Switch the unit ON and test the operation and then replace the front panel.

2.3 COMMISSIONING

It is essential that all systems function properly for optimum performance. To achieve this, the primary system should be commissioned in accordance with good practice and generally in accordance with the requirements of BS 6798, BS 5449 and BS 7593. Full details of the requirements are given in PAS 33:1999 under section 10 Commissioning.

Cleansing the Primary System

When using either cleansing or corrosion inhibitor chemical, the manufacturers instructions must be followed.

When determining the quantity of cleanser required, be sure to allow for the increased volume of water in the primary circuit due to the thermal store. See section 1.2 Technical Data for volumes.

Primary Water System Treatment

Although the ElectraMate 2000 has no special water treatment requirements, the radiators and other parts of the circuit will benefit from the application of a scale and corrosion inhibitor such as Sentinel X100 or a protector such as Fernox MB1. When determining the quantity of inhibitor required, be sure to allow for the increased volume of water in the primary circuit due to the thermal store - see Section 1.2 Technical Data for volumes.

The following procedures should be used during the final fill/before commissioning the appliance.

1. Isolate the heating element temporarily by removing the two 30 amp fuses and put them in a safe place.
2. Check the air pressure in the expansion vessel is set to the correct pressure and adjust if necessary.
3. Open the automatic air vent which is positioned at the top of the appliance.
4. Open the incoming stop valve and fill the domestic mains cold and hot water systems.
5. Open the 90° angle isolating valve provided immediately upstream of the C.A Valve to fill the appliance/sealed heating system. The whole of the primary sealed heating system will automatically be filled to 1.0 bar with potable water through the pressure regulating and CA type backflow prevention valves provided as part of the ElectraMate 2000. Add inhibitor to the system in the normal way whilst the system is filling. Once full check the whole of the primary heating and domestic hot and cold distribution systems for leaks.
6. Once the system has been filled the electrical connection and system controls should be checked in line with page 25. Once this has been done the system should be operated for a few minutes without the heating elements being switched on which will allow any air trapped in the system to be vented. The appliance should be switched on and the heating pump should be activated by operating the programmable room thermostat in line with the instructions on page 25. The automatic air vent should remain open until all air has been removed from the system.

NOTE : Pump speeds should be set as follows:

The space heating pump should be set at a speed at which the temperature difference across the heating circuit close to the unit boiler is at least 11°C or as specified by the system designers. The pump characteristics are shown in Section 1.2 Technical Data. The domestic hot water plate heat exchanger pump should always be set at maximum speed (i.e. speed III)

The boiler flow pump should always be set at speed III.

Once all the air has been vented from the system the two 30 amp fuses should be replaced and the heating element should be checked for its correct operation which will be indicated by a current draw of approximately 45 amps on the incoming supply.

Check the operation of the appliance in line with the instructions on page 26.

After all the air in the system has been vented, which could be several days, the automatic air vent should be closed to prevent any possibility of a leak in the event that any system debris finds its way into the valve.

ONCE THE COMMISSIONING PROCESS IS COMPLETE DO NOT SWITCH THIS APPLIANCE OFF AT THE ISOLATOR SWITCH EVEN WHEN THE PROPERTY IS EMPTY. THE PUMPS ARE TURNED AUTOMATICALLY EVERY 24 HOURS TO PREVENT THEM STICKING AND THIS WILL NOT HAPPEN IF THE APPLIANCE IS ISOLATED. THE ROOM THERMOSTAT CAN BE TURNED DOWN SO THAT THE HEATING WILL NOT OPERATE. THE RUNNING COSTS WILL THEN ONLY BE ENOUGH TO KEEP THE APPLIANCE ON STANDBY.

Powerflushing/Cleaning of the Heating System

If it is proposed to 'powerflush' the heating system we would recommend that the ElectraMate appliance is isolated from the heating system being cleaned. Failure to do this could seriously damage the appliance.

When carrying out the work always comply fully with the manufacturers instructions for the powerflushing equipment being used - See Section 10.

If in any doubt please consult our Technical Helpline.

2.0 INSTALLATION

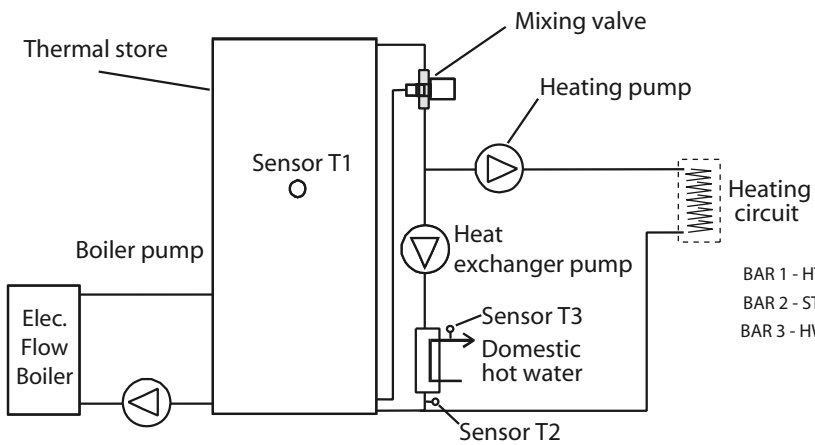

2.3 COMMISSIONING

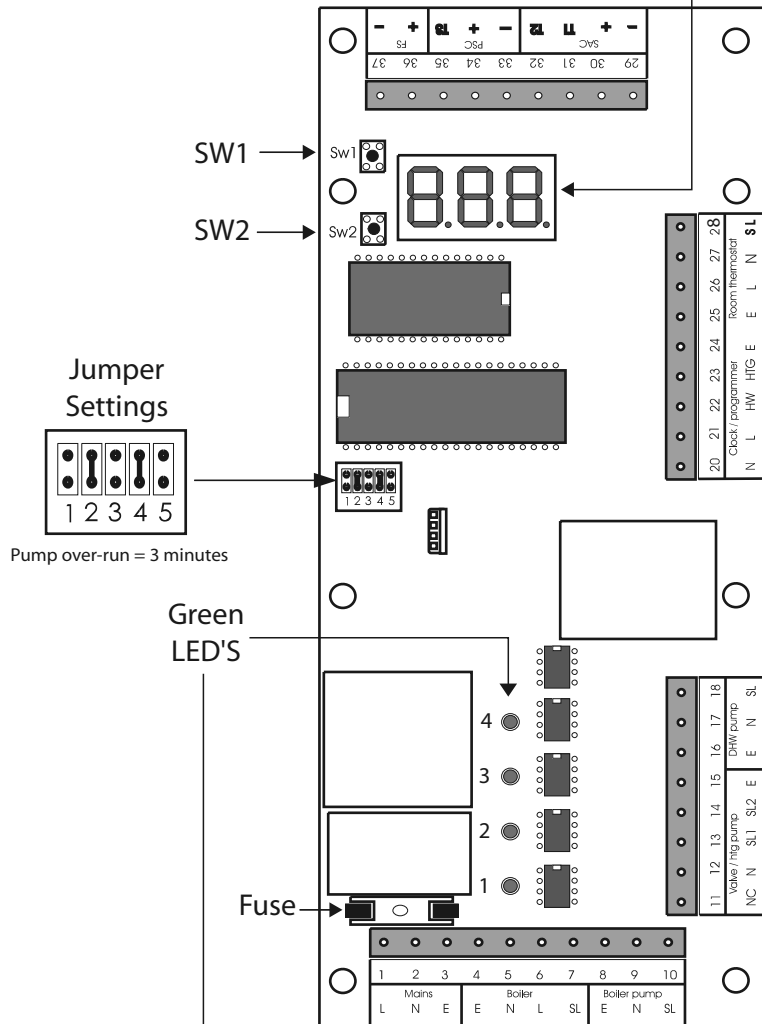
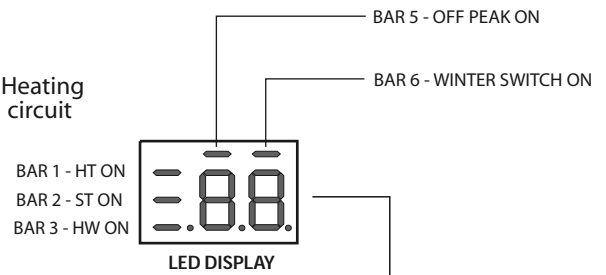

APPLIANCE CONTROL BOARD (A.C.B)

- 4 = PERMANENTLY ON
- 3 = HEATING PUMP ON
- 2 = BOILER PUMP ON
- 1 = ELEC. BOILER ON

2.3 COMMISSIONING

Powering the system/appliance

The appliance will automatically commission when it is switched on. However it is essential that the following steps are carried out to check the correct functioning of all the controls.

Before switching ON the mains supply to the appliance check that :

1. 45A mains electricity supply to terminals 'L' 'N' 'E' are correctly connected and the protection device is of the correct rating.
2. Programmable Room Thermostat is correctly wired to terminals 25, 26, 27 and 28.
3. Off peak signal (230V 50Hz) is connected to the terminals 'L' 'N' on the small tele-switch PCB.
4. Two jumpers are present across 2 & 4 on the ACB as shown opposite.

The control system/ACB has been initialised at the factory and will operate automatically. However, the operation of the control system should be checked as follows on the ACB (shown opposite).

Programmable Room Thermostat

To test space heating first check the programmable room thermostat (TP5E). Slide the battery cover to the left to reveal the programming buttons (PROG, +, -). Press the + and - buttons together until the display shows the actual room temperature. In the middle of the right hand side of the LCD display the current set point temp. value will be displayed, this is the temperature that the ElectraMate is controlling to. The programmed control temperature may be changed temporarily using the ▲ and ▼ buttons until the required temperature is shown.

A ▼ or ▲ arrow will appear in the display as a reminder that the programmed setting has been over-ridden. This over-ride is cancelled at the next programmed switching.

The large display in this mode is indicating the current actual temperature of the room.

Press the ▲ button once for each degree increase until a flame symbol is displayed and a click is heard.

Horizontal bar 'HT' will light on the LCD display and green LED-3 will switch on and the water from the store will be circulated to the radiators by the heating pump.



Danfoss TP5E Programmable Room Thermostat

2.3 COMMISSIONING

Switch off space heating from the programmer or room thermostat. Horizontal bar on the LCD screen 'HT' will switch off and green LED-3 will switch off. The heating pump will stop circulating water to the radiator circuit.

1. Move the Summer/Winter switch.
Horizontal bar '2' (above the 'n') will light on the LCD display when the switch is in the winter position.
2. Check operation of 'on-peak/off-peak' detection by switching the main signal to PCB.
When 'off-peak' signal is present, the horizontal bar '1' (above the '0') on the LCD display will light.
3. Turn the hot water tap on and off. When the hot water tap is opened the horizontal bar 'DHW' will light when the hot water is running.

Note : The heating pump will automatically be switched off when hot water is being drawn.

4. When the store is charging the green LED's 1 and 2 on the pcb will be lit.
When the store has finished charging, the green LED 1 will switch off and after 3 minutes the green LED 2 will switch off.

The ElectraMate 2000 has a **SUMMER/WINTER** switch.

During the months when heating is not required, switch to summer mode. This is an energy saving function and the unit will continue to provide hot water on demand.

To keep the cupboard temperature to a minimum in summer it is recommended that any exposed hot water/heating pipework in the cupboard is insulated.

A link is fitted between terminals 21 & 22 on the appliance control board. This allows the appliance to be charged automatically at any time under control of the store thermostat.

The internal controls automatically select the store charge temperature and control thermostat differential to suit the electricity tariff. The temperature settings established during commissioning can be checked using push button switches sw1 and sw2 on the PCB as described in Section 3.4 Fault Finding.

This product is covered by the 'Benchmark' scheme and a separate commissioning/ service log book is included with this product. This must be completed during commissioning and left with the product to meet the warranty conditions offered by Gledhill.

On completion :

1. Do ensure that the electrical connections (e.g. mains supply, room thermostat) to the unit are correct and tight.
2. Do ensure that the functioning and control of the system including the programmable room thermostat is explained to the occupant.
3. **DON'T** place any clothing or other combustible materials against or on top of this appliance.

These Instructions should be placed along with the component manufacturers instructions in the pocket provided on the rear of the front panel. The front panel should then be refitted.

When the system has been commissioned and all the air released from the initial fill close the AAV cap.

Use as necessary in the future when carrying out any repairs/modifications to the system/appliance to ensure the appliance vessel is not damaged during draining down and then close again as the above.

3.0 SERVICING

3.1 ANNUAL SERVICING

No annual servicing of the ElectraMate 2000 is necessary.

However, we would recommend that checks on the appliance controls and a hot water performance test are carried out annually to prove the appliance is working satisfactorily and within its specification.

3.2 CHANGING/ COMPONENTS

This appliance has two independent electrical supplies. Ensure that both supplies are isolated before removing the front panel to undertake any work.

Free of charge replacements for any faulty components are available from Gledhill during the in-warranty period (normally 12 months).

After this, spares can be obtained direct from Gledhill using the 'Speed Spares' service, or through any of the larger plumbers merchants/ specialist heating spares suppliers.

Help and advice is also available from the Technical Helpline on 08449 310000.

However, all components are readily accessible and can be changed quickly and easily by the installer using common plumbing practice.

If it is necessary to replace any of the pumps fitted to the appliance the pump head (motor pack) only should be removed as recommended by Grundfos. Assuming it is within warranty this will be accepted by a merchant as being covered by the Grundfos national service exchange agreement, as long as it is a complete pump i.e. alleged faulty motor pack and new base is left with the merchant. It is important when a pump has been replaced to ensure that any air is adequately vented.

If the heater bottles are being replaced it is important that the appliance is run without the elements being live to ensure any air is removed from the bottles and the elements are not dry fired. To ensure this occurs the heater bottle fuses should be removed and only replaced once you are sure any air has been removed.

WARNING : There are no user serviceable parts inside the appliance cover. All annual inspections and/or servicing must be carried out by suitably qualified and competent persons.

3.0 SERVICING

3.3 SHORT PARTS LIST

Key No.	Description	Manufacturer	Stock Code No.	Gas Council Part No.
1	Plate heat exchanger	Swep	GT017	E05 664
2	3 Port mixing valve		XC006	E82-593
3	1/2" Relief valve		GT195	E37 478
4	Non return valve	Detail Plastic Co.	GT048	E37-479
5	Anti vacuum valve		GT056	E05 679
6	1/2" Automatic air vent		GT015	E02 759
7	SWITCH 9kW electric flow boiler	Wardtec	XB342	
8	Grundfos 15-50 pump	Grundfos	XB004	384 288
9	22mm Ball type pump valve	Vemco	XB121	E26 010
10	22mm Ball 'O' fix valve		GT024	E25 995
11	40 litre Expansion vessel	Reliance	XB304	E39 157
12	25 litre Expansion vessel	Reliance	XG165	
13	Appliance control board	Elok	GT155	E39 158
14	PHE return sensor	Elok	GT153 (Extended)	
15	Store sensor	Elok	GT149	E26 022
16	DHW sensor	Elok	GT153	E26 024
17	Danfoss TP5E Programmable Room T/Stat	Danfoss	XB365	
18	Summer/Winter switch		GT034	E05 678
19	Boiler/Store Overheat Thermostat(manual reset)		GT064	397 978
20	AC30 fuse base	Proteus	XB388	
21	25 Amp fuse		XB364	
22	20mm high break fuse 5 Amp		XB382	E39 162
23	Power relay		XB298	E39 163
24	CA Backflow prevention valve	Watts Industries	XB391/2	
25	Pressure reducing valve	Watts Industries	XB390	
26	Primary system pressure gauge		GT179	
27	90° Angle Ballvalve	Gascon	XB398	

3.0 SERVICING

3.3 SHORT PARTS LIST

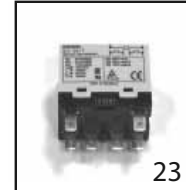
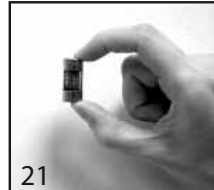
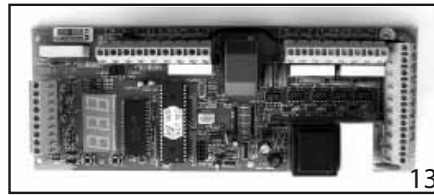

FAULTS AND THEIR CAUSES

Any fault in the system design or malfunction of system components will generate customer complaints. These can be grouped into the following three main categories:-

- The system is noisy
- Hot water service is unsatisfactory
- Space heating service is unsatisfactory

CAUSES OF A 'NOISY' SYSTEM

Noisy heating pump operation:-

- Check the pressure in the system, which should not be less than 1.0 bar when cold and vent if necessary.
- Check the pump speed setting of the heating system pump - reduce if necessary but ensure that the temperature difference is about 11°C.
- If the system is noisy when in heating mode only - check and adjust if necessary the system bypass (if fitted).

Noisy electric flow boiler operation:-

- Check the flow rate through the integral electric boiler when switched on by measuring the temperature rise across the boiler. If the temperature rise is greater than 11°C, then increase the pump speed.
- Check the pressure in the system which should not be less than 1.0 bar when cold and vent if necessary.

Noise when hot water is opened:-

- If the pump is noisy when the hot water tap is opened, then check the system pressure which should not be less than 1.0 bar and vent the pump if necessary.
- Water hammer - loose pipework and/or tap washers.

CAUSES OF 'UNSATISFACTORY HOT WATER SERVICE'

1. Check the pressure in the system which should not be less than 1.0 bar.
2. Check that the electric flow boiler is working normally.
3. Check that the 3 port mixing valve is set to maximum i.e. setting '4'.
4. Check that the store is being charged to the correct set point temperatures for the summer/winter switch position and the on/off peak supply as shown on page 32.
5. Check that the hot water plate heat exchanger pump starts when the hot water tap is opened and stops shortly after the tap is closed.
6. Check that the plate heat exchanger pump is set at maximum speed.
7. Check that the hot water outlet temperature does not change significantly when the hot water flow rate is increased from say 5 litres/min to 15 litres/min.
8. Check that the space heating load is not greater than specified for the unit and that the occupant knows how to use the programmable room thermostat.

3.4 FAULT FINDING

9. If 1 to 8 are correct then it is likely that the performance of the heat exchanger is impaired by scale. In this case the hot water flow rate will be noticeably less than the cold. Replace it with a factory exchange unit and re-check hot water performance.

CAUSES OF 'UNSATISFACTORY SPACE HEATING'

1. Check the pressure in the system which should not be less than 1.0 bar.
2. Check that the switch on the front panel is in the winter position.
3. Check that the 3 port mixing valve is set to maximum i.e. setting '4'.
4. Check that the electric flow boiler is working.
5. Check that the store is being charged to the correct set point temperature in winter.
6. Check that the space heating load is not greater than specified for the unit.
7. Check that the flow temperature is at least 70°C. If not check functioning of the 3 port mixing valve - adjust or replace if necessary.
8. Check the operation and the settings of the programmable room thermostat.
9. If some rooms are not being heated properly, then increase the pump speed to establish a temperature difference of 11°C and if necessary balance the system/ check the operation of any TRV's.

POWERFLUSHING/ CLEANING OF THE HEATING SYSTEM

If it is proposed to 'powerflush' the heating system we would recommend that the ElectraMate appliance is isolated from the heating system being cleaned. Failure to do this could seriously damage the appliance.

When carrying out the work always comply fully with the manufacturers instructions for the powerflushing equipment being used.

If in any doubt please consult our Technical Helpline.

3.0 SERVICING

3.4 FAULT FINDING

The operation of the ACB itself can be checked as follows :

- Switch off mains.
- Check/insert correct jumpers i.e. across 2 and 4.
- Insert jumper 5.
- Switch on mains.
- The PCB will carry out functional tests and then stop. LED's 1-4 will be switched ON then OFF at 5 second intervals and the output number will be indicated on the LED display. When complete the LED display will be as follows : 
- Switch off mains.
- Remove jumper 5.
- Switch on mains to put into normal mode.

If there is any discharge from the Pressure Relief Safety Valve.

- Check that the system is not over-pressurised when cold - nominal charge pressure should be about 1.0 bar.
- Check that the air pressure inside the expansion vessel is correct - refill with air if necessary to nominal value of 1.0 bar when the system is **de-pressurised**.
- Check that the expansion vessel is correctly sized for the system volume.
- Check the pressure relief valve seat - replace if necessary.

The boiler overheat thermostat will trip (pop-out) if :

- The Boiler pump is faulty.
- The control thermostat on PCB is faulty.
- The System is air locked i.e poor circulation through electric boiler circuit.

Check and replace faulty parts and manually push the reset button on the boiler overheat thermostat.

If the store overheat thermostat has activated or failed, it is important to check the boiler pump and store temperature sensor are working correctly. Remove the cap on the **STORE** o/heat t/stat, if this has popped out you must replace the **BOILER** o/heat t/stat. Press the reset button and replace the cap on the **STORE** o/heat t/stat. Check that the boiler pump is operating and that the pump switches off when the store temperature sensor is up to its operating temperatures - see page 32 for details.

If the **BOILER** o/heat t/stat or the **STORE** o/heat t/stat continue to activate then please contact the manufacturers for advice.

WARNING : UNDER NO CIRCUMSTANCES SHOULD THESE TWO SAFETY CONTROLS BE MANUALLY HELD DOWN OR TAKEN OUT OF CIRCUIT.

3.0 SERVICING

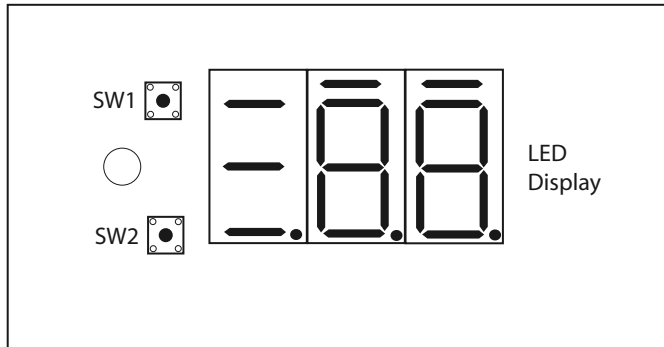

The ACB can be used to establish/check the operating and set temperatures of the appliance as well as identify faults on any of the 3 sensors. This is done by operating switches SW1 and SW2 as shown opposite and reading the LED display.

Store T1, PHE T2, and DHW T3 indicate the current value being read by the store, PHE and DHW sensors respectively. The location of the sensors is shown in Section 2.3 Commissioning.

SUMMER/WINTER SWITCH	WINTER
T1_OFF : 65/70*	(ON PEAK PERIOD)
T1_ON : 55/60*	(ON PEAK PERIOD)
T1_OFF : 85	(OFF PEAK PERIOD)
T1_ON : 80	(OFF PEAK PERIOD)
SUMMER/WINTER SWITCH	SUMMER
T1_OFF : 65	(ON PEAK PERIOD)
T1_ON : 55	(ON PEAK PERIOD)
T1_OFF : 75	(OFF PEAK PERIOD)
T1_ON : 70	(OFF PEAK PERIOD)

T1 ON and T1 OFF show the store temperature set points. T1 ON shows the temperature at which the store will call for heat, i.e signal the boiler to fire. T2 OFF shows the temperature at which the store will be satisfied, i.e signal the boiler to switch off.

These set point temperatures will vary dependant on the position of the summer/winter switch and whether the appliance is sensing an 'on' or 'off' peak electrical supply. The set point temperatures are shown in the table opposite.

In addition to the main LED display the ACB has four green LED'S which can be used to check a supply is being provided when required to the Boiler (LED 1), Boiler pump (LED 2) and Heating pump (LED 3). LED 4 is not used on this appliance. For further details refer to Section 2.3 Commissioning.

Note : If the ACB is replaced it will automatically initialize itself when the electricity supply is switched on.

The operation of the system controls/operation should then be checked.

The same appliance control board is used on a number of appliances and the jumpers **MUST** be in the correct position for the appliance to work satisfactorily, see Section 2.3 Commissioning for details.

When requesting a visit from the manufacturer the installer must have the completed 'Benchmark' commissioning/service record sheet to hand to enable help to be provided.

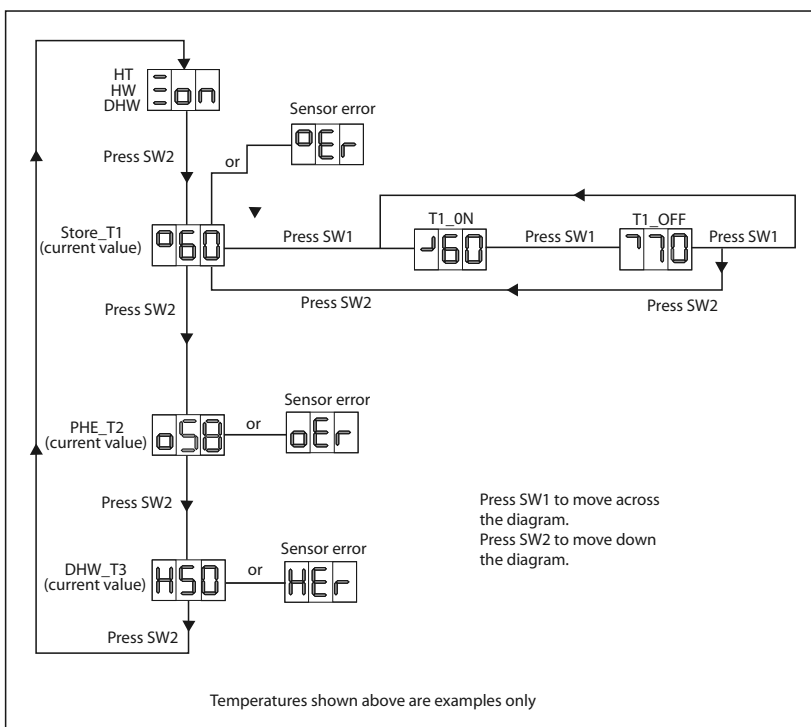

WATER SAVINGS

WATER RELATED COSTS CAN BE REDUCED BY GOOD PLUMBING PRACTICE.

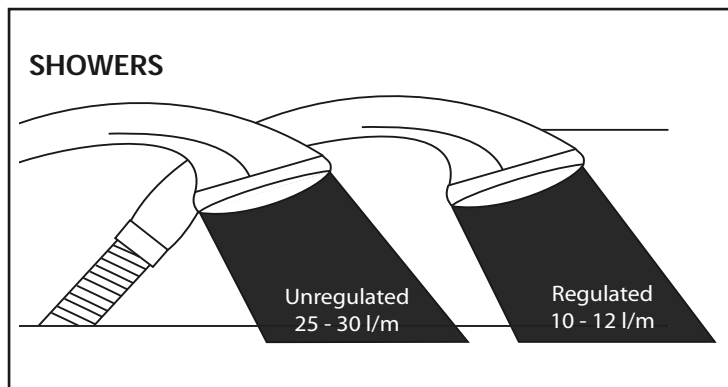
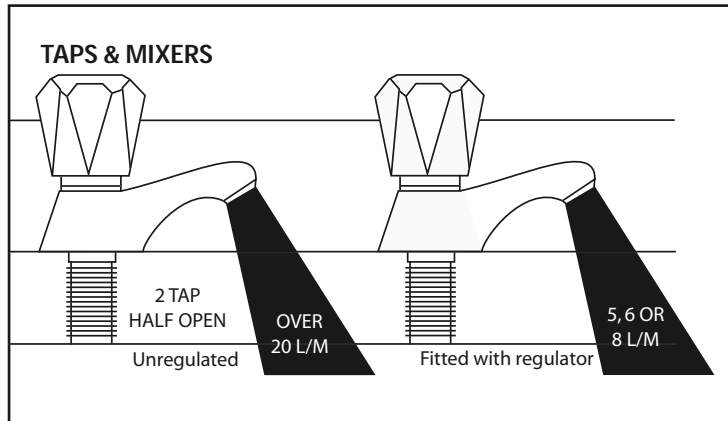

Vast quantities of water are needlessly run off to waste due to Taps, Mixers and Showers discharging flow rates far in excess of the rates required for them to perform their duties.

The contrasting flow rates shown on this leaflet clearly illustrate the savings that can be made whilst still providing a good performance.

British made Aquaflow Regulators provide constant flow rates by automatically compensating for supply pressure changes between 1 bar & 10 bars.

To facilitate installation into the wide range of plumbing equipment which is encountered in the U.K, Four Fixing Options are available:-

OPTIONS FOR SHOWERS

1. MXF "DW" Range - For fitting behind Fixed Shower Heads or onto Flexible Hoses for Handshowers (preferably onto the inlet end when lightweight hoses are used).
2. Compression Fitting Range. "In Line" regulators as in Option 4 for Taps & Mixers.

Information by courtesy of

AQUAFLOW REGULATORS LTD

Haywood House, 40 New Road, Stourbridge, West Midlands DY8 1PA
TELEPHONE (01384) 442611 FAX: (01384) 442612

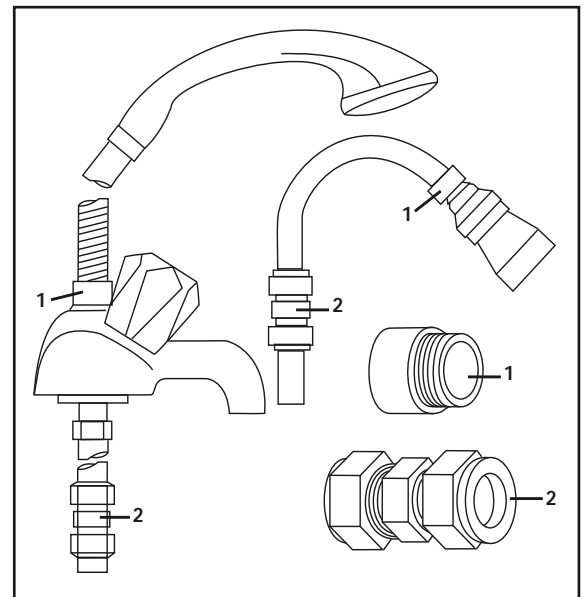

4 FIXING OPTIONS FOR TAPS & MIXERS

1. MK Range - Combined Regulators & Aerators for screwing onto Taps & Mixers with internal or external threads on their noses. Anti Vandal models also available.
2. MR05-T Range - Internal Regulators. Push-fit into Tap or Mixer seats. Produced in three sizes - 12.5mm (BS1010), 12mm & 10mm, Flangeless models also available for Taps with Low Lift washers.
3. MXF Standard Range - Screw on tail models for Taps & Mixers. Fix onto the tails before fitting the tap connectors. Available in 3/8", 1/2", 3/4" and 1" BSP.
4. Compression Fitting Range - "In Line" regulators housed in 15mm & 22mm CXC Couplers & Isolating Valves. "UK WFB" listed by the Water Research Centre. Isolation valves available for slotted screwdriver operation or with coloured plastic handles. Now available also in plastic bodied push-fit couplers & valves.

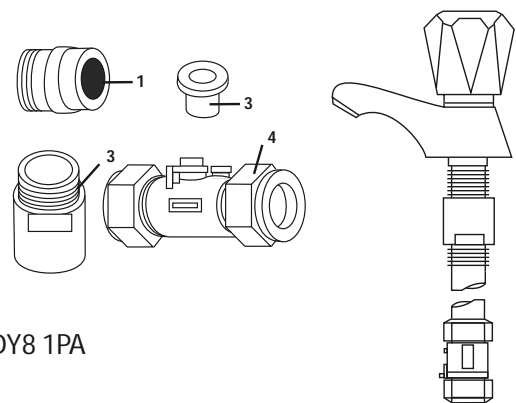

APPENDIX B

MANIFOLDS

Manifold type: 1 - Stock Code MIP 050 (one bathroom, one en suite shower room, one cloakroom, one kitchen)			
Flow regulator (litres/minutes)	Terminal fitting	Hot water manifold outlets Quantity	Cold water manifold outlets Quantity
18	Bath tap	1	1
9	Hand basin	3	3
12	Kitchen sink	1	1
9	Toilet cistern	None	3
9	Shower	1	1
12	Washing machine	1	1
9	Dishwasher	None	1
	Total	7	11

Two sets of manifolds are available as an optional extra. Each set comprises a separate hot and cold water manifold. Both are provided with a 22mm inlet connection located centrally. All outlet connections are 15mm compression. The centre to centre dimension of each branch is 55mm.

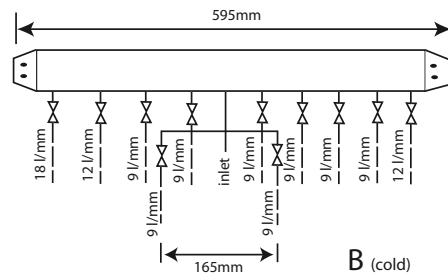
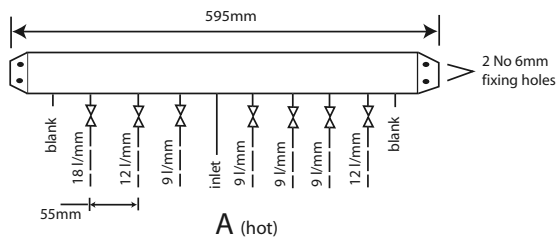

Manifold type: 2 - Stock Code MIP 060 (two bathrooms, one en suite shower room, one cloakroom, one kitchen, one utility room)			
Flow regulator (litres/minutes)	Terminal fitting	Hot water manifold outlets Quantity	Cold water manifold outlets Quantity
18	Bath tap	2	2
9	Hand basin	4	4
12	Kitchen sink	2	2
9	Toilet cistern	None	4
9	Shower	1	1
12	Washing machine	1	1
9	Dishwasher	None	1
	Total	10	15

The arrangement of each manifold is supplied as shown. This provides the best balance of flows but the flow regulators/duty of each branch can be changed if required as long as a reasonable balance is maintained. If it is necessary to change or clean the flow regulator this can be done without needing to drain the system by closing the valve and removing the screwed cover below the white plastic cover.

The manifolds are designed to be used with plastic pipework and are supplied complete with isolation valves and flow regulators on each branch. They would normally be installed in the same cupboard as the thermal storage appliance (on page 36) but can be installed in another cupboard close to the appliance if required.

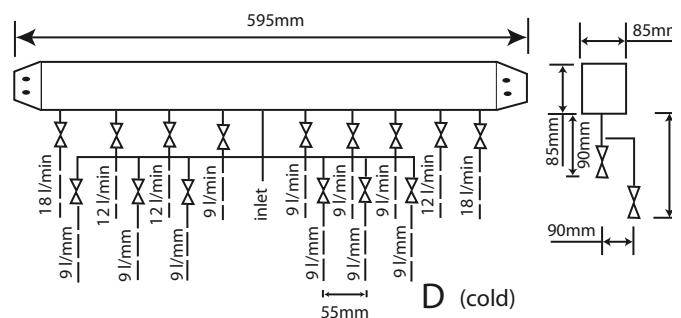
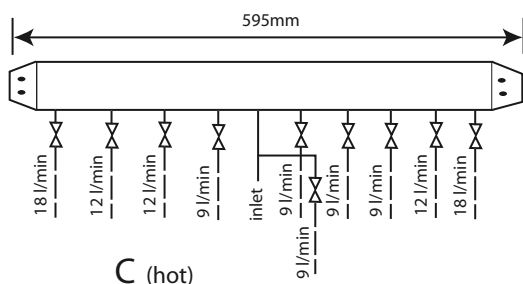

APPENDIX B

An optional location where cupboard space is tight



The pressure loss through a flow regulator at the designated flow rate is about 1.8 bar. Therefore for the flow regulator to control the flow rate at pre-set level, the inlet pressure must be greater than 1.8 bar. If the inlet pressure is lower, the flow rate will be correspondingly less than the pre-set values.

The maximum equivalent pipe lengths from the manifold to the terminal fittings can be estimated from the above information and the resistance characteristics of the pipes. The examples presented below are for 15mm copper pipe in table 1 and for plastic pipework in table 2.



The preferred solution where space will allow

Table 1: Maximum equivalent pipe length in 15mm copper			
Inlet pressure (bar)	Maximum equivalent length of pipe (m)		
	@ 9 l/m	@ 12 l/m	@ 18 l/m
2.0	25	10	5
2.5	75	30	15
3.0	150	60	30

Table 2: Maximum equivalent pipe length in plastic pipe			
Inlet pressure (bar)	Maximum equivalent length of pipe (m)		
	@ 9 l/m	@ 12 l/m	@ 18 l/m
2.0	1.5	15mm : 10	15mm : 4.5 22mm : 40
2.5	3.0	15mm : 20	15mm : 9.0 22mm : 80.0
3.0	4.5	15mm : 30	15mm : 13.5 22mm : 120

APPENDIX B

The size of the distribution pipes supplying the manifold should be calculated using the method set out in BS 6700. A typical diagrammatic arrangement of a system using Manifold Type 1 is shown below. This is only meant to show the principles involved and the actual connection of fittings to the manifold will need to suit the arrangements shown on page 35.

Note 1 - If it is proposed to fit chemical water treatment such as a water softener this should be fitted in this location and the cold water branch in the sink should be branched off the cold water main prior to the treatment device instead of the cold water manifold.

Any other isolating/control valves and backflow protection devices should be provided as necessary to comply with the Water Regulations.

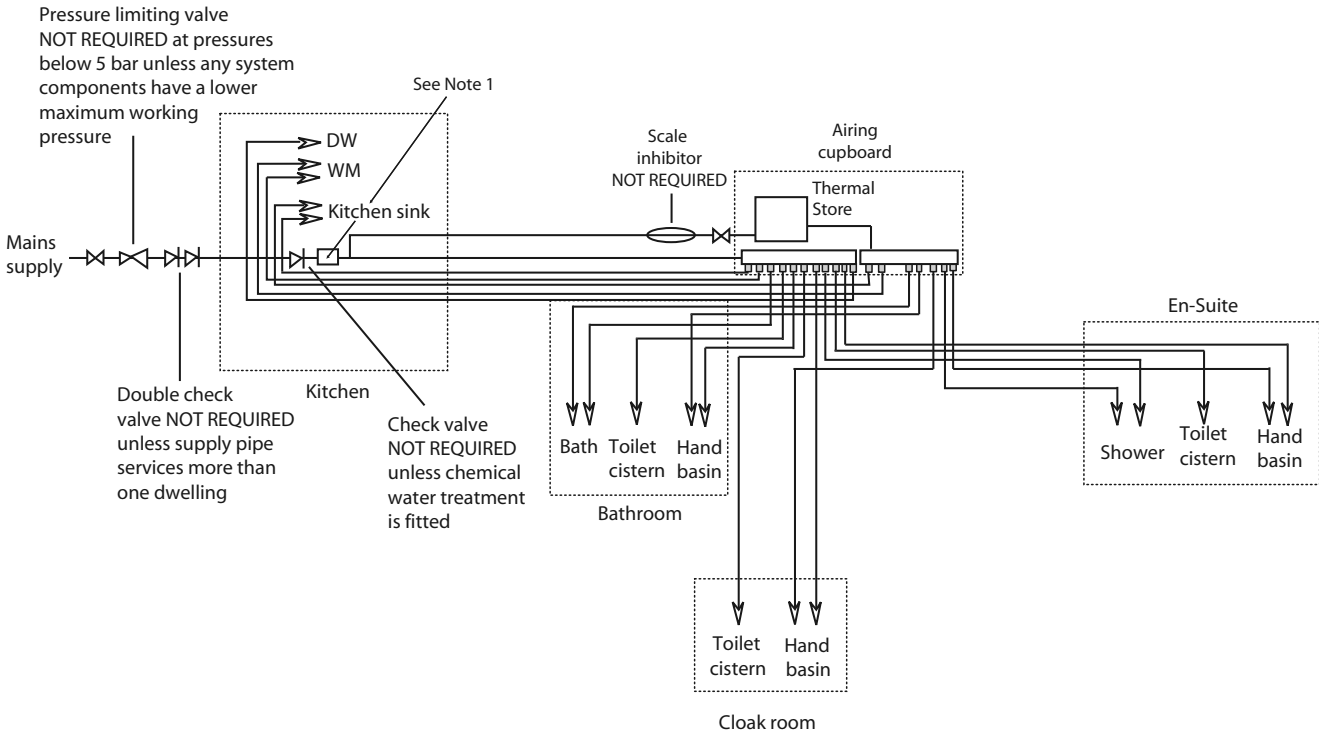



2 Inhibitor (Corrosion & scale protection of primary heating circuit)

On filling the heating system and before the boiler is fired up, it is important to ensure the system water is treated with a suitable corrosion inhibitor, in accordance with the boiler manufacturer's instructions.

Since the concentration of inhibitor present in a system can become diluted, for a number of different reasons, the system should be checked annually and re-treated as required, or after every full or partial drain-down. A water treatment manufacturer's test kit may be used to check the correct concentration of inhibitor in the system.

Where recommended by a boiler manufacturer, a 'physical corrosion protection device' may be fitted in the primary pipework in accordance with the boiler manufacturer's instructions.

The Benchmark log book should be completed indicating the date and details of any of the above products added and a permanent label should be fixed to the system in a prominent location.



3 Scale protection (Domestic hot water service)

Where a combi boiler and/or a hot water storage vessel is installed in areas where the mains water can exceed 200ppm Total Hardness (as defined by BS 7593: 1993 Table 2) a scale reduction device should be installed, in accordance with the boiler manufacturer's instructions.

The levels of water hardness may be measured using a water hardness test kit.

BUILDING REGULATIONS

Completion of the BENCHMARK log book requires that the 'competent person' undertaking the installation and commissioning provide information relating to Cleaning, Inhibitor and Scale Protection. This will demonstrate that the work complies with the requirements of the appropriate Building Regulations.

This Guidance Note is produced on behalf of its members by the Central Heating Information Council. For a full list of members visit www.centralheating.co.uk and for further advice on water treatment contact the following members:

Culligan Sentinel Ferno Salamander Engineering Scalemaster

Heating & Hotwater Information Council, 36 Holly Walk, Leamington Spa, Warwickshire CV32 4LY Tel: 0845 600 2200 Fax: 01926 423284

www.centralheating.co.uk



Benchmark is managed by The Heating & Hotwater Information Council

MANUAL HANDLING OF APPLIANCE PRODUCTS

Description

Manual handling means any transporting or supporting of a load (including lifting, putting down, pushing, pulling, carrying or moving) by hand or bodily force.

Scope

This assessment will cover the largest Appliances, namely ElectroMats, GulfStream, BoilerMats, SynteMats, PulseCoil, Accolade and Stainless Lite manufactured by Gledhill.

The maximum weight of the largest product in each range is 90kg and the size is 595 x 595 x 2020 mm high.

Main Hazards

Vision may not be clear due to the size of the products. Adopting an incorrect method of lifting may cause injury, attempting to lift these products will require help from others. (Team lifts)

Control Measures

Manual lifting procedure

The lift, key factors in safe lifting are:

- a. Balance
- b. Position of back
- c. Positioning of the arms and body
- d. The hold
- e. Taking the lead for team lifts

a. **Balance** - Since balance depends essentially upon the position of the feet, they should be apart about hip breadth with one foot advanced giving full balance sideways and forward without tension. In taking up this position, lifting is done by bending at the knees instead of the hips and the muscles that are brought into use are those of the thigh and not the back.

b. **Position of back** - Straight - not necessary vertical. The spine must be kept rigid, this coupled with a bent knee position, allows the centre line of gravity of the body to be over the weight so reducing strain.

c. **Positioning of arms and body** - The further arms are away from the side, the greater the strain on the shoulder, chest and back. Keep elbows close to the body arms should be straight.

d. **The hold** - Before lifting ensure you have a good hold. Two handles are provided on Appliance products at the top rear side, these allow one or two persons to have a purposely-designed hold at the top of the appliance to ensure easy lifting at the top of the product. Each appliance is supplied with a pallet, which has been attached to the unit via the packaging. The pallet will also allow for one or two persons to get a good hold.

e. **Taking the lead for team lifts** - As more than one person is required for these products ensure that one person is taking the lead. This may be you so ensure that each person that is helping is made aware of the weight and of the items listed within this assessment. Make sure you and any others helping know the route you intend to take that it is clear of any obstructions. Never jerk the lead as this will add a little extra force and can cause severe strain to the arms, back and shoulders. If there are steps involved decide on where you will stop and take a rest period. Move smoothly and in unison taking care to look and listen to others helping with the lift. Where possible use a sack truck to move the product over long flat distances, only lift the products when necessary. If in doubt stop and get more help. The unit handles and packaging with the pallet have been designed to ensure that two-four people can assist when lifting up stairs or over longer distance.

Individual capability

Individual capability plays an important part in handling these products. Persons above average build and strength will find it easier and should be in good health. Persons below average build and strength may require more rest periods during the handling process.

Pregnant women should not carry out this operation.

Persons who are not in good health should seek medical advice prior to commencing any lifting or manual handling operation.

Residual risk

Following the guidelines given above will reduce any risk to injury.

All persons carrying out this operation must be fully trained and copies of the specific risk assessment made available for inspection and use in their training process.

Further guidance on Manual Handling can be obtained from the Health and Safety Executive. Manual Handling Operations Regulations 1992.

Gledhill (Water Storage) Ltd

AMD, JUNE 2008

CONDITIONS OF SALE & GUARANTEE TERMS

1. Gledhill (Water Storage) Ltd ("We" or "Gledhill") only do business upon the Conditions which appear below and no other. Unless we so agree in writing these Conditions shall apply in full to any supply of goods by us to the execution of any Conditions or terms sought to be imposed by any purchaser. These Conditions of Sale and Warranty Terms override those which are contained on the Invoice Form and all Sales as are subject to these Conditions of Sale and Warranty terms only.

2. PRICE

Once an order or call off has been accepted the price will be held for three months but if delivery is estimated beyond that period at the customer's request, then we reserve the right to amend the price when necessary. The company reserves its pricing normally to adjust for changes in material costs. We reserve the right to alter prices at any time for various movements in raw materials (copper and steel). If there is to be a change you will give customers at least four weeks notice but anything delivered after that date will be at the revised price. An order may not be cancelled or varied after acceptance without the written consent of the company. Such cancellation or variation shall be subject to such necessary changes as may be appropriate.

3. SPECIFICATIONS

The goods are supplied in accordance with the Specifications (if any) submitted to the Purchaser and any additional and alterations shall be the subject of an extra charge. Any goods not as specified shall be in accordance with our printed literature or the literature of any of our component suppliers (subject to any modifications made since publication). If we accept any changes in construction or design of the goods, or in the specifications printed in our literature, the Purchaser shall accept the goods as designed in fulfillment of the order.

4. PAYMENT

The invoice price of goods shall be payable within 30 days of dispatch by us or of invoice for the goods or such longer time as may be stated by our quotation or invoice. Even where payment is deferred or instalments are made we will allow an appropriate discount (amount) unless you have quoted a special net price. If payment is not received in full over the due date we shall be entitled in addition to the invoice price to:

- (i) payment of a sum equal to any increase in the copper price supplement applicable to the particular goods sold between the date of receipt of order and the date of receipt of payment in full; and
- (ii) interest on any part of the invoice price unpaid after the due date at the rate of 3% per annum over the base rate for the time being of THE Bank plc.

5. TITLE

We give estimates of delivery dates in good faith and time of delivery is not or shall be made of the essence of any contract nor shall we be liable for any loss or damage occasioned by delay in delivery.

6. DELIVERY

We deliver normally by our own vehicles within 25 miles of any of our manufacturing depots. Delivery to any place more than 25 miles from one of our manufacturing depots may be subject to our special delivery charges. We reserve the right to make delivery of goods contained in one order by more than one consignment and at different times. Where a parcel is signed for delivery and such parcel is not obtained by our Agent, the Purchaser shall take delivery within that period. If the Purchaser fails to take delivery, we shall be entitled at the Purchaser's risk and expense to store the goods at the Purchaser's premises or elsewhere and to demand payment as if they had been dispatched. Off loading at point of delivery shall be the responsibility of and to undertake by the Purchaser.

7. SIGNATURE OR DELIVERY

Goods need be inspected before signature of delivery note and any damage, shortage or discrepancy noted on the delivery note and the goods released on the same vehicle. The buyer must also give us immediate written notice of the damage, shortage or discrepancy so that we may prompt investigation.

8. RETURN OF GOODS

Goods may not be returned to the Company except by prior written permission of an authorized officer of the Company and such return shall be subject to payment by the Purchaser of freighting and re-stocking charges, transport and all other costs incurred by the Company.

9. COMPANY LIABILITY AND GUARANTEE

9.1. Subject to the terms of these Conditions of Sale and General Terms Gledhill provides Guarantee of specific products as set out in this clause.

9.2. Each Guarantee is strictly conditional upon the following:-

- 9.2.1. Complaints must be given to us immediately, before any action is taken, as responsibility cannot be accepted if repairs or measures are attempted on site without our written approval.
- 9.2.2. The unit has been installed in accordance with our installation and service instructions and all relevant codes of practice and regulations in force at the time of installation.
- 9.2.3. All necessary inlet controls and safety valves have been fitted correctly.
- 9.2.4. The unit has only been used for the design of potable water supplied from the public mains.
- 9.2.5. Where appropriate the unit has been regularly maintained as detailed in the installation and service instructions.
- 9.2.6. Defects caused by corrosion or scale deposits are not covered by any Guarantee.
- 9.2.7. Where we agree to modify any defect we reserve the right to undertake the work on our own premises.

9.3. Guarantees are provided in respect of specified goods supplied by Gledhill as follows:-

(i) Domestic and Commercial Open Vented Cylinders and Tanks.

The copper storage vessel is guaranteed for ten years and if it proves to be defective either in materials or workmanship, we will either repair or supply replacement at our option with the closest substitute in the case of any obsolete product to any address in Great Britain.

(ii) Free of all charge during the first year after delivery by us.

(iii) Thereafter at a charge of one-tenth of the then current list price and any copper price supplement and delivery charge during the second year after delivery by us and increasing by a further one-tenth on the second and subsequent anniversary of delivery by us.

(iv) Domestic Hot Water Pumps (Primary/Secondary)

The copper storage vessel is guaranteed for ten years and if it or any integral pipework as part of the storage vessel assembly proves to be defective either in materials or workmanship, we reserve the right to either repair or supply replacements or the closest possible substitute in the case of any obsolete product and will collect and deliver to any address in England, Wales and Scotland (excluding all Scottish islands).

(i) Free of all charge during the first year after delivery by us.

(ii) Thereafter at a charge of one-tenth of the then current list price or any copper price supplement and delivery charge during the second year after delivery by us increasing by a further one-tenth on the second and subsequent anniversary of delivery by us.

(iii) Integrated Boiler and Storage Tank Products and Stand Alone Boilers

In the case of the full range of products and the Gledhill boiler range of products, Gledhill guarantees as the best exchange (either for material and construction faults for two years. THE RESPONSIBILITY FOR THE EXECUTION OF THIS GUARANTEE LIES WITH THE INSTALLER.

The guarantee becomes null and void if the appliance is used incorrectly, or in the event of proven negligence or incorrectly implemented repairs OR FAILURE TO CHECK GUY WIRE RECOMMENDED MAINTENANCE/BLINDING. The guarantee also becomes null and void if changes are made to the appliance without our knowledge, or if the serial number on the appliance is untraceable under the legislation.

The annual service must be carried out by a competent installer in accordance with the advice given by Gledhill and using Gledhill approved parts.

(iv) Washers, Heat Unvented Cylinders

Gledhill guarantees the compressor including controls, valves and electrical parts for two years from the date of purchase. IT SHOULD BE NOTED THAT THE FACTORY FITTED TEMPERATURE AND PRESSURE RELIEF VALVE MUST NOT BE REMOVED OR ALTERED IN ANY WAY OR THE GUARANTEE WILL NOT BE VALID. GLEDHILL WILL NOT BE RESPONSIBLE FOR ANY CONSEQUENTIAL LOSS OR DAMAGE HOWEVER IT IS CAUSED.

The guarantee for the stainless steel vessel is for twenty five years if the original unit is returned to us AND PROVIDED THAT:

- (i) It has been installed as per the Design, Installation & Servicing Instructions, relevant standards, regulations and codes of practice.
- (ii) It has not been modified, other than by Gledhill.
- (iii) It has not been subjected to misuse or improper use or full annual test.
- (iv) It has not been used for the storage of potable water.
- (v) It has not been subjected to fire damage.
- (vi) The benchmark log book is completed after each annual service.
- (vii) The unit has been serviced annually.

It should be noted that the guarantee does not cover:-

- the effects of a scale build up
- any labour charges associated with replacing the unit or parts.

If the stainless steel vessel proves to be defective either in materials or workmanship we reserve the right to either repair or supply replacements or the closest possible substitute in the case of any obsolete product and will collect and deliver to any address in England, Scotland and Wales (excluding all islands).

(i) Free of charge during the first year after delivery by us.

(ii) Thereafter at a charge of one-tenth of the then current list price during the second year after delivery by us and increasing by a further one-tenth fifth on the second and subsequent anniversary of delivery by us.

ACCORDING TO THE EVENT OF FAILURE.

If the stainless steel cylinder develops a leak we will either a) repair or replace the supply of a new one. This will be subject to the failure is within the terms of the warranty when it has been accepted by us.

(b) Water Pumps and auxiliary equipment

Gledhill provides a five year warranty for defects in the collection (except broken glass and collector accessories as noted elsewhere). If the collector demonstrably fails to meet one of the requirements of the standard BS147 part 3 we will replace it free of charge based on the date of invoice. We can not be responsible for damage caused by mechanical stress and/or damage caused by weather related influences. The warranty includes minor surface damage that does not affect performance or collection due to improper assembly or installation.

Please note

- Installation must have been carried out by a licensed specialist company (plumbing contractor or plumber) following the written of installation instructions in force.

- Gledhill or its representative can claim the opportunity to check compliance on site immediately after any defect occurred.

- Construction states that the system was constructed properly and that the system was checked and maintained on performance annually by a specialist company licensed for this purpose.

(c) Components of our products other than Storage Vessels and Integral Pipework.

We will either extend to the purchaser the same terms of warranty as we are given by the manufacturer of the component or if the manufacturer does not give any warranty, replace free of charge any component which becomes defective within ten years after the date of the delivery by us and is returned to us at the purchaser's expense but we shall not meet the cost of removal or shipping or return of the component or any other cost charges or damage incurred by the purchaser.

If the appliance manufactured by Gledhill incurs a factory fitted scale inhibitor then during the period

of these years from the date of delivery Glanville will replace, free of charge, any plastic fuel exchange fitted in the appliance to which equipment in which recall installation occurred, provided the effectiveness of the plastic fuel exchange. This guarantee does not extend to any other component installed within the Glanville appliance or elsewhere in the Purchaser's domestic water system.

6.8.

6.8.1. In respect of goods supplied by us and in respect of any installation work carried out by us or our staff, our entire liability and the purchaser's sole recourse (subject to the Escrowed £) shall be as follows:-

- (a) We accept liability for death or personal injury to the extent that it results from our negligence or that of our employees
- (b) Subject to the other provisions of this clause 6 we accept liability for direct physical damage to tangible property to the extent that such damage is caused by our negligence or that of our employees, agents or subcontractors.
- (c) Our total liability to the purchaser over and above any liability to replace under the Guarantee (whether in contract or in tort including negligence) in respect of any one claim or loss or damage claimed to result from any breach of our obligations hereunder, shall be limited to actual monetary damages which shall not exceed £25,000 provided that such monetary limit shall not apply to any liability on the part of ourselves referred to in paragraph (a) above
- (d) Except as provided in paragraph (c) above but otherwise not withstanding any provision herein contained in no event shall we be liable for the following loss or damage to ourselves caused and over if these shall be by us or in our contemplation:-
 - (i) economic loss which shall include loss of profits, business revenues, goodwill or anticipated savings
 - (ii) damage in respect of special interest or consequential loss or damage (other than death, personal injury and damage to tangible property)
 - (iii) any claim made against the purchaser by any other party (save as expressly provided in paragraph (b) above)
- (e) Except in respect of our liability referred to in paragraph (a) above we shall not be made or claim brought (whether in contract or in tort including negligence) by the purchaser in respect of any goods supplied by us more than one year after the date of the breach for the relevant goods.
- (f) Without prejudice to any other term we shall not be liable for any water damage caused directly or indirectly as a result of any leak or other defect in the goods. We cannot control the conditions of use of the goods or the time or manner or location in which they will be installed and the purchaser agrees to be fully responsible for testing and checking all vessels which include the goods at all relevant times prior to, including and after commissioning, and for taking all necessary steps to identify any leaks and prevent any damage being caused thereby.
- (g) Nothing in these Conditions shall confer on the purchaser any rights or remedies in which the purchaser would not otherwise be lawfully entitled

7. LOSS OF EARNINGS

Notwithstanding any other provision contained herein the purchaser hereby agrees to fully indemnify us against any damages losses costs claims or expenses incurred by us in respect of any claim brought against us by any third party:-

- (a) any loss injury or damage wholly or partly caused by any goods supplied by us or their use.
- (b) any loss injury or damage wholly or partly caused by the defective installation or substantial workmanship or materials used in the installation of any goods supplied by us.
- (c) any loss injury or damage in any way connected with the performance of this contract.
- (d) any loss resulting from any failure by the purchaser to comply with its obligations under these terms to to install and/or check vessels correctly.

PROVIDED that this paragraph will not require the purchaser to indemnify us against any liability for our own acts of negligence or those of our employees or agents or our subcontractors.

FURTHER in the case of goods supplied by us which are re-sold and certified by a third party by the purchaser it will be the sole responsibility of the purchaser to test the goods immediately after their installation to ensure that later also they are correctly installed and in proper working order free from leaks and are not likely to cause any loss injury or damage to any person or property.

11. VARIATION OF WARRANTY AND EXCLUSION

Should our warranty and exclusion be unacceptable you are prepared to negotiate for variation in their terms but only on the basis of an increase in the price to allow for any additional liability or risk which may result from the variation.

Purchasers are advised to insure against any risk or liability which they may incur and which is not covered by our warranty.

12. RISK AND RETENTION OF TITLE

- (a) Goods supplied by us shall be at the Purchaser's risk immediately upon delivery to the Purchaser or into custody of the Purchaser's staff or in the Purchaser's Debt. The Purchaser shall effect adequate insurance of the goods against all risks in the full market value of the goods, such insurance to be effective from the time of delivery until property in the goods shall pass to the Purchaser as hereinafter provided.
- (b) Property in the goods supplied hereunder will pass to the Purchaser when full payment has been made by the Purchaser to us for:-
 - (i) the goods of the subject of this contract.
 - (ii) all other goods the subject to of any other contract between the Purchaser and us which, at the time of payment of the full price of the goods sold under this contract, have been delivered to the Purchaser but not paid for in full.
- (c) until property in the goods supplied hereunder passes to the Purchaser in accordance with paragraph (b) above.
 - (i) The Purchaser shall hold the goods in a fiduciary capacity for us and shall store the same separately from any other goods in the Purchaser's possession and in a manner which enables them to be identified as our goods.
 - (ii) The Purchaser shall immediately return the goods to us should our staff make representation on request. All the necessary incidents are attached with a fiduciary relationship shall apply.
- (d) the Purchaser's right to possess the goods shall cease forthwith upon the happening of any of the following events, namely:-
 - (i) if the Purchaser fails to make payment in full for the goods within the time stipulated in clause 4 hereof.
 - (ii) if the Purchaser, not being a company, commits any act of bankruptcy, makes a proposal to his or her creditors for a composition or does anything which would entitle a petition for a Bankruptcy Order to be presented.
 - (iii) if the Purchaser, being a company, does anything or fails to do anything which would entitle an administrator or an administrative receiver or a receiver to take possession of any assets or which would entitle any person to present a petition for winding up or to apply for an administration order.
- (e) the Purchaser hereby grants to us an irrevocable licence to enter at any time any vehicle or premises owned or occupied by the Purchaser or in the possession of the Purchaser for the purpose of representing and

recovering any such goods the property in which has remained in us under paragraph (2) above. We shall not be responsible for and the Purchaser will indemnify us against liability in respect of damage caused to any vehicle or premises to such representation and removal being damaged which it was not reasonably practicable to avoid.

- (f) notwithstanding paragraph (b) hereof and subject to paragraph (7) hereof, the Purchaser shall be permitted to sell the goods to third parties in the normal course of business. In this regard the Purchaser shall act in the capacity of our commission agent and the proceeds of such sale:-
 - (i) shall be held in trust for us in a manner which enables such proceeds to be identified as such, and;
 - (ii) shall not be mixed with other monies nor paid into an overdrawn bank account.

We, as principal, shall nominate the Purchaser as commission agent a commission depending upon the supplier which the Purchaser can obtain over and above the sum stipulated in this contract of supply which shall satisfy us.

- (g) In the event that the Purchaser shall sell any of the goods pursuant to clause (f) hereof, the Purchaser shall forthwith inform us in writing of such sale and of the identity and address of the third party to whom the goods have been sold.
- (h) If, in tort property in the goods passes to the Purchaser under paragraph (2) above the goods are or become attached to any land or building owned by the Purchaser it is hereby agreed and declared that such attachment shall not have the effect of passing property in the goods to the Purchaser. Furthermore if, before property in the goods shall pass to the Purchaser under paragraph (2) hereof, the goods are or become attached to any land or building (whether or not owned by the Purchaser), the Purchaser shall:-
 - (i) insure the goods as capital of being attached without material injury to such land or building.
 - (ii) take all necessary steps to prevent title to the goods from passing to the tenant of such land or building.
 - (iii) forthwith inform us in writing of such attachment and of the address of the land or building concerned.

The Purchaser warrants to repair and make good any damage caused by the alteration of the goods or their removal from any land or building and to indemnify us against all loss damage or liability we may incur or sustain as a result of alteration or removal.

- (i) In the event that, before property in the goods has passed to the Purchaser under paragraph (2) hereof, the goods or any of them are lost, stolen, damaged or destroyed:-
 - (ii) the Purchaser shall forthwith inform us in writing of the fact and circumstances of such loss, theft, damage or destruction.
 - (iii) the Purchaser shall assign to us the benefit of any insurance claim in respect of the goods so lost, stolen, damaged or destroyed.

13. NON-PAYMENT

If the Purchaser shall fail to make full payment for the goods supplied hereunder within the time stipulated in clause 4 hereof or in the event of payment for any other reason then, without prejudice to any of our other rights hereunder, we shall be entitled to stop all deliveries of goods and materials to the Purchaser, including deliveries or further deliveries of goods under this contract. In addition we shall be entitled to terminate all outstanding orders.

14. VALUE ADDED TAX

All prices quoted are exclusive of Value Added Tax which will be charged at the rate ruling at the date of dispatch of goods.

15. WHOLE SALES ONLY

We are only prepared to deal with those who are not connected with the terms of the Unfair Contract Terms Act 1977, the Sale of Goods Act 1979 and the Supply of Goods and Services Act 1982. Accordingly any person who purchases from us shall be deemed to have represented that he is not a consumer by so purchasing.

16. JURISDICTION

The agreement is subject to English law for contracts delivered in England and Scottish law for contracts delivered in Scotland and any dispute hereunder shall be settled in accordance with the law of the country in which the location.

17. WHOLE SALES ONLY

We are only prepared to deal with those who are not connected with the terms of the Unfair Contract Terms Act 1977, the Sale of Goods Act 1979 and the Supply of Goods and Services Act 1982. Accordingly any person who purchases from us shall be deemed to have represented that he is not a consumer by so purchasing.

16. JURISDICTION

The agreement is subject to English law for contracts delivered in England and Scottish law for contracts delivered in Scotland and any dispute hereunder shall be settled in accordance with the law of the country in which the location.

