

# **Camec Keyless Entry System Operating Instructions**

# Congratulations on your purchase of a Camec Keyless Entry System.

## Overview

Your Keyless Entry System has three modes of operation;

1. Online Mode (12V supply from the caravan)
2. Battery Mode (Internal battery supply)
3. Traditional key operation.

The Camec Keyless Entry System can be activated by either:

- a. Traditional keys (2 keys are provided)
- b. Electronic fobs - 1 x red (Master) and 2 x blue (user) fobs are provided.
- c. Optional bracelet or adjustable wrist band available from your Camec RV dealer. (Up to 3 additional fobs can be programmed. Total number of fobs is 6, 5 fobs plus master).

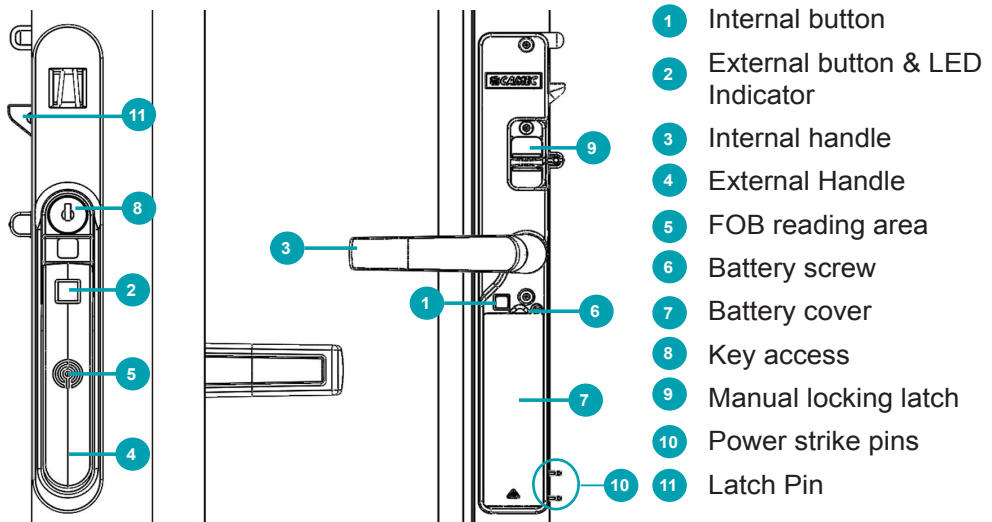

## Master (Red) Fob

The Camec Keyless Entry system is encrypted with 128bit security and cannot be programmed unless one of the original fobs is used to initiate the programming sequence. Therefore we recommend that the red master fob be stored separately (for example hidden in the tow vehicle) so if the other fobs are lost, new fobs can be programmed.

## Operating your Keyless Entry - Online Mode

Power (+12V) from your caravan's battery system is supplied to the Keyless Entry via the powered striker unit mounted on the door frame of your Camec entry door.

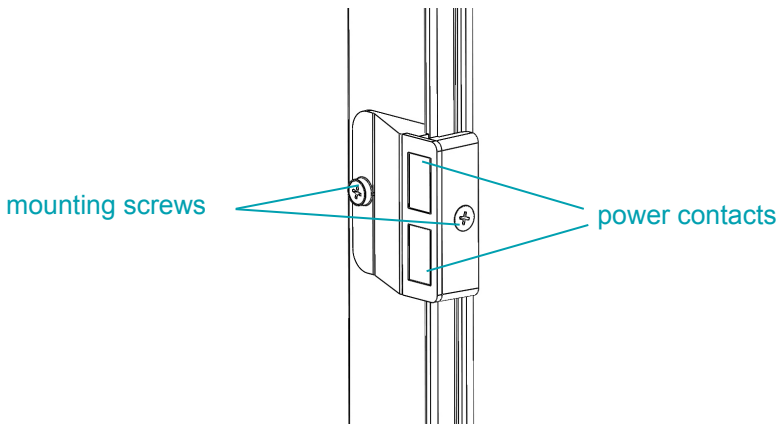

When the door is closed, and the caravan battery is switched on, the button located on the outer handle will glow green. This indicates a permanent +12V supply is active to the lock.

When the door is open, the lock will automatically switch to battery mode (when batteries have been fitted)

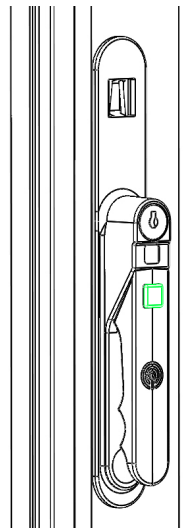

## To Unlock:

Place the tag or wrist band in close proximity (max 2cm) to the reader, which is identified by the  sign on the outer handle.

- The lock will sound 2 short beeps for a successful read
- The handle will extend to unlock the door
- The lock will sound 3 short beeps for an unsuccessful read and button will flash red 3 times.

If the read is unsuccessful, try holding the fob near the reader for a longer period, otherwise fob may require reprogramming. See programming instructions.

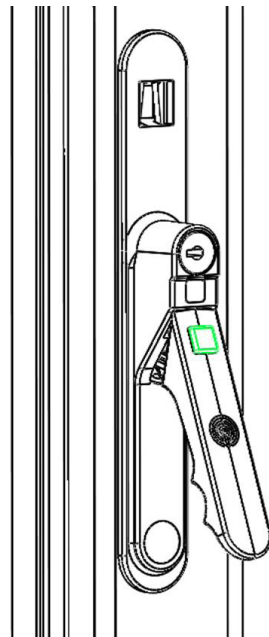
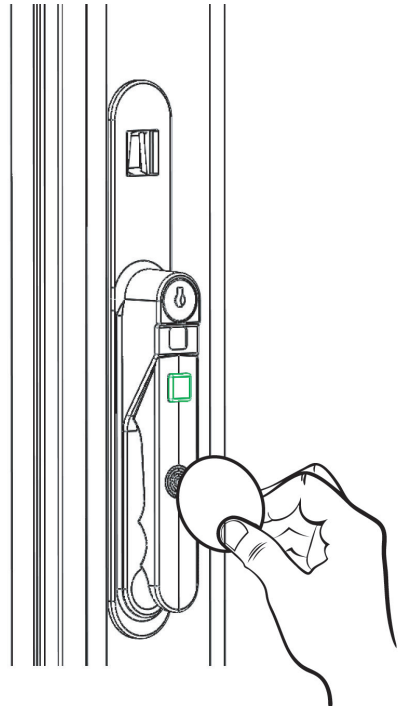

## To Lock:

- Close the door to the caravan.
- Place the tag or wrist band in close proximity (max 2cm) to the reader
- The lock will sound 2 short beeps for a successful read
- The handle will retract and lock the door.
- The lock will sound 3 short beeps for an unsuccessful read and button will flash red 3 times.

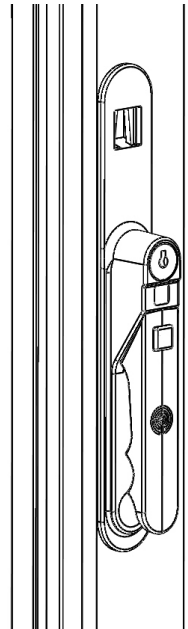
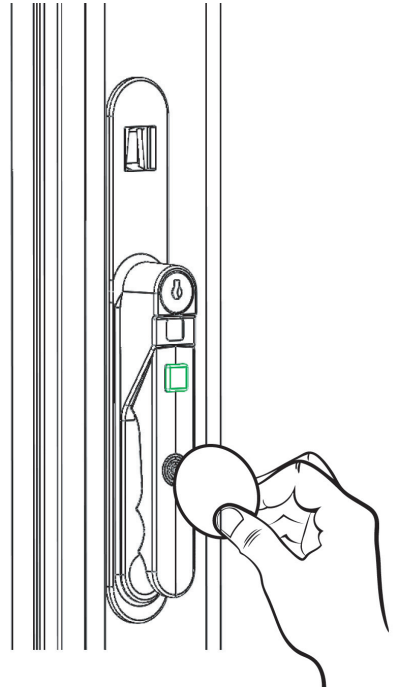

# Operating your Keyless Entry - Battery Mode

Your Keyless Entry unit can operate on 4x Camec AA Alkaline batteries.

Internal battery mode is activated on the Keyless Entry system in a number of situations. If your RV does not have a 12V battery fitted, or if it becomes flat, the Camec Keyless Entry System will operate on it's internal batteries. Also when the door is open, the Keyless Entry System will operate on the internal batteries as the unit will not receive power from the power striker in this position. The system can operate for up to 12 months per set of Camec Alkaline Batteries or similar high quality alkaline battery.

## Installing the AA batteries

- Remove the battery cover from the inner lock housing using a PH0 point screw driver, to remove fixing screw and lift off cover plate
- Insert 4x Camec Alkaline AA batteries (supplied) into battery tray as per the markings (confirm battery orientation in the holder)
- Replace battery cover and fasten the screw

Once batteries are installed, the button located on the outer handle will flash green once every 5 seconds to indicate battery mode.

If batteries are low, external button will flash red 2 times every 5 seconds.

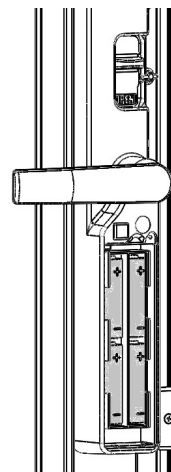
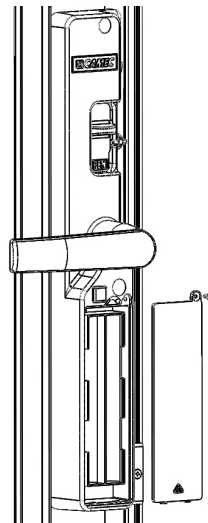

## To Unlock:

- Press the button on located on the outer handle to initiate fob read request
- The lock will sound 1 long beep and the button will illuminate green while searching for the fob
- Place the fob or wrist band in close proximity (max 2cm) to the reader
- The lock will sound 2 short beeps for a successful read
- The handle will extend to unlock the door.
- The lock will sound 3 short beeps for an unsuccessful read and button will flash red 3 times.

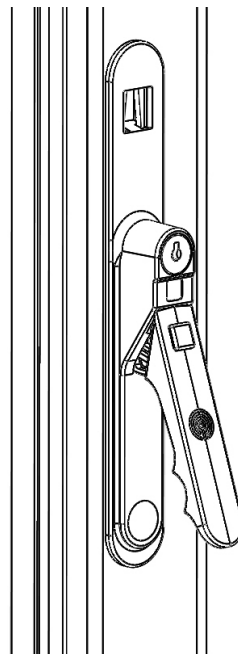
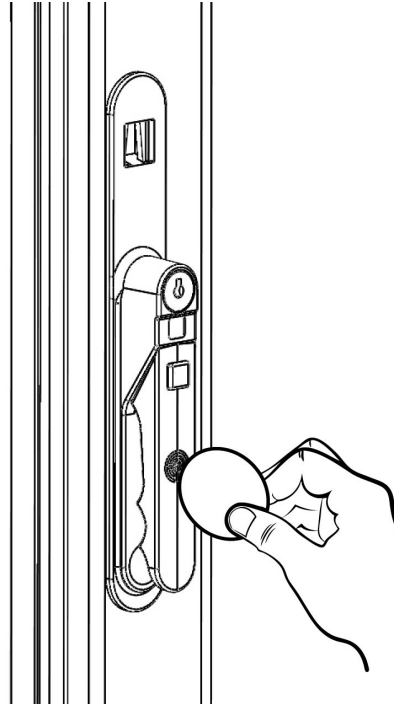

## To Lock:

- Close the door to the caravan.
- Press the button located on the outer handle to initiate fob read request
- Place the fob or wrist band in close proximity (max 2cm) to the reader
- The lock will sound 2 short beeps for a successful read
- The handle will retract and lock the door
- The lock will sound 3 short beeps for an unsuccessful read and button will flash red 3 times.

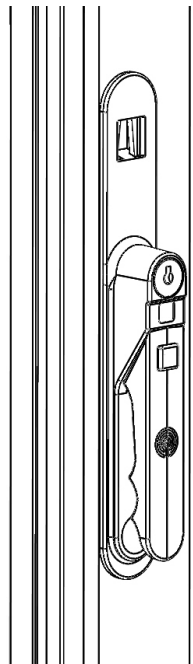
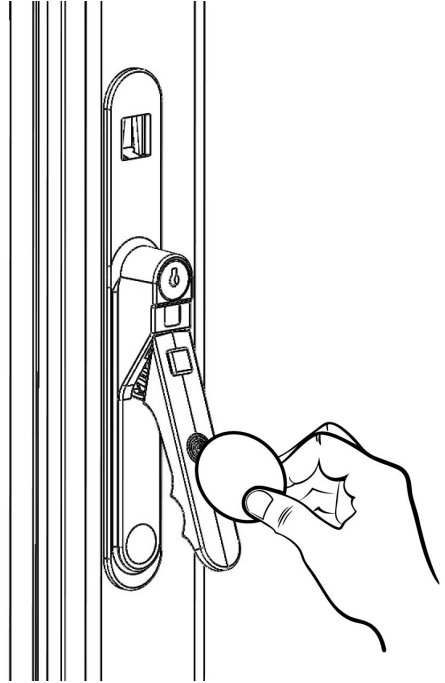



# Operating your Keyless Entry - Traditional Key

Your Keyless Entry system can also be operated using a traditional key system.

## To Unlock:

- Insert the key provided into the keyhole
- Turn key anticlockwise
- The handle will extend to unlock the door.

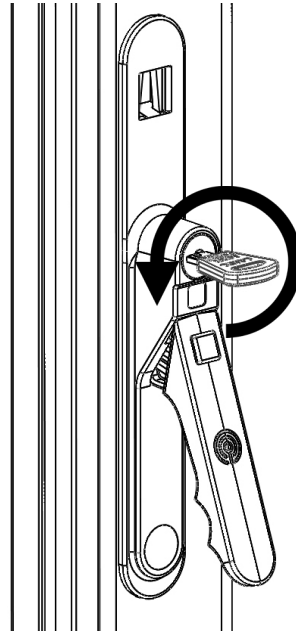

## To Lock:

- Insert the key provided into the keyhole
- Turn key clockwise
- The handle will retract and lock the door.

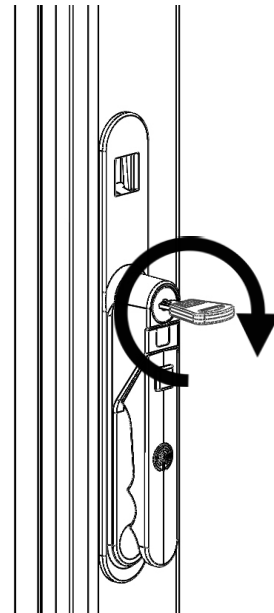

## Operating your Keyless Entry - Internal Button

Your Keyless Entry system can be operated using the internal button, when in either Online Mode or Battery Mode.

### To Unlock:

- Press the internal button once
- The lock will sound 2 short beeps
- The internal lock snib will slide up, unlocking the door, and the word 'Open' on the snib will become visible
- The external handle will also extend out.

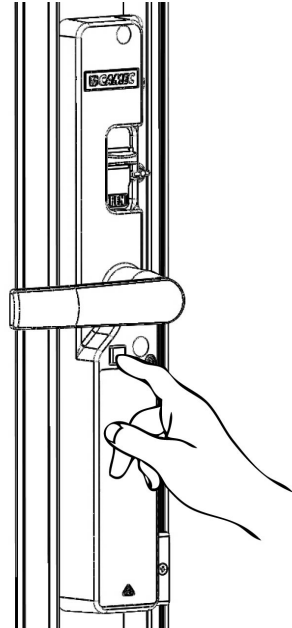

### To Lock:

- Press the internal button once
- The lock will sound 2 short beeps
- The internal lock snib will slide down, locking the door, and the word 'Open' on the snib will no longer be visible
- The external handle will also retract becoming flush with outer door.

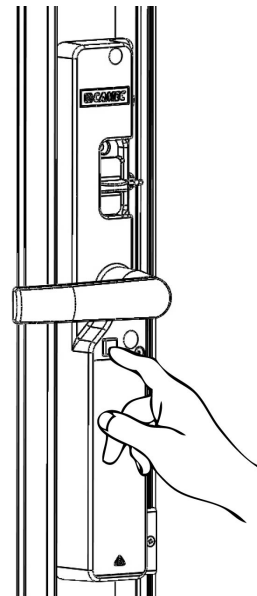

## Warnings

- Do not short out the contacts on the powered strike, for risk of electrical damage to the system
- Do not directly spray water onto the internal components of the lock, or under the handle when door is unlocked.
- It is recommended that the lock be locked (external handle retracted) while cleaning
- Fuse for the powered striker is recommended to be max 2A
- We recommend replacing the 4x AA batteries every 12 months, with Camec AA Alkaline units.
- We recommend to clean the powered strike and power pins, every two months using a clean, dry, lint free cloth
- Always lock door when travelling.

## Troubleshooting

1. Fob will not lock/unlock the door
  - 1.1 Confirm that the fob has been programmed to the Keyless Entry unit – See programming instructions
  - 1.2 Fob may be damaged – See your nearest Camec retailer
  - 1.3 Confirm Keyless Entry is either in Online or Battery modes by observing the outer button LED.
2. My lock will not switch to Online Mode
  - 2.1 Confirm there is 12V at the powered striker
    - 2.1.1 Confirm that fuse is not blown – consult your dealer for fuse location
  - 2.2 Clean the power striker and the lock power pins, and confirm good contact between the two when door is closed
3. I have lost all my fobs
  - 3.1 You can continue to use your traditional key to lock and unlock your door
  - 3.2 Contact your nearest Camec retailer for advice

# Programming Instructions

## Programming New Fobs

- Please ensure that batteries in good condition are installed in the keyless entry system before programming or Fob deletion.
- Open the RV's door so the inside button and outside fob reader are accessible.
- Press and hold the inside button for 5 seconds until multiple high beeps are heard
- Release button then Swipe the Master (Red) Fob over the reader
- Confirmation that the lock is in programming mode after the Fob Swipe will be with 2 x long high tones
- Now swipe the new fob to be programmed.
- A correct swipe of the new Fob will be verified with 2 x short high tones
- An incorrect swipe of the new Fob will result in 3 x long low tones. If this happens, try swiping the Fob again. If the Fob still cannot be programmed, you may have a faulty Fob or all 6 Fob memory locations may be used. Please consult "Deleting a Fob" to clear space for additional Fob programming.
- Once programming mode is completed, this will be signified with 2 x long low tones

## Deleting fobs

- Open the RV's door so the inside button and outside fob reader are accessible
- Press and hold inside AND outside buttons simultaneously for 5 seconds until multiple low tones are heard
- Confirmation of all fob deletion (excluding master(s)) after releasing the buttons is verified with 2 x long high beeps

## Replacement & Spare Parts

- Keyless Entry System Left Hand – 044435
- Keyless Entry System Right Hand – 044436
- Blue Fob – 044438
- Red Fob – 044439
- Teal Bracelet Small – 044440
- Teal Bracelet Large – 044441
- Keyless Entry Powered Strike - 044443

V1.00 © Camec 2017

Camec Pty Ltd, 47-63 Remington Drive, Dandenong South Vic 3175

[www.camec.com](http://www.camec.com)