



# ELITE PRO<sup>®</sup> 2 Caravan Mover

## User Manual

Model: CAMEC ELITE PRO<sup>®</sup> 2 EM305

Part No: 043322

For Professional Installation Only



\*Not suitable for rear shackle type suspensions  
Updated Jan 2017

## TABLE OF CONTENTS

Package contents (parts list)	Page 3
Introduction	Page 4
Intended use	Page 4
Specifications	Page 4
Installation - safety guidelines	Page 5
Installation - mechanical components	Page 6
Installation - electrical/electronic components	Page 8
installation - twin axle	Page 10
Operation - safety guidelines	Page 12
Operation - motor units	Page 13
Operation - remote control handset	Page 14
Operation - electronic control unit	Page 16
Operation - getting started	Page 17
Operation - hitching and unhitching	Page 18
Maintenance	Page 18
Troubleshooting	Page 18

## PACKAGE CONTENTS

Ref	Qty	Description
1	1	Motor unit (A)
2	1	Motor unit (B)
3	1	Main cross bar
4	1	Electronic control unit
5	1	Remote control handset with lanyard
6	1	Emergency key
7	2	Aluminium chassis clamp plates (set)
8	4	Bolt - M10x60
9	2	Chassis U plate
10	1	Instruction manual
11	2	Convuluted cable trunking
14	1	Positive (+) red battery cable 1.8m including fuse holder & 80A fuse
15	1	Negative (-) black battery cable 1.6m
16	8	Bolt - M10x50
17	12	Nylon nut M10
18	24	Washer 10mmØ
19	20	Screw - M4x15
20	10	Cable trunking P-clips 19.2mm
21	10	Cable P-clips 10.4mm
22	4	Battery terminal connector 8mmØ
23	2	Battery terminal connector 6mmØ
24	4	Spade fork connector (large)
25	3	Cable number markers (1,2,3,4)
26	3	Cable polarity markers (+,-)
27	4	Spade fork connector (small)
28	10	Cable ties 2x70
29	1	Battery isolation switch, cover & key
30	2	Roller distance spacers 20x20
31	2	Rubber isolation shell for battery isolation switch
32	1	Remote control handset wall holder
33	2	Screw – M5x40
34	2	Chassis clamp plates (pair)
35	6	Bolt - M8x70
36	6	Nylon nut M8
37	12	Washer 8mmØ
38	6	Spring washer 8mmØ

**Package Contents**

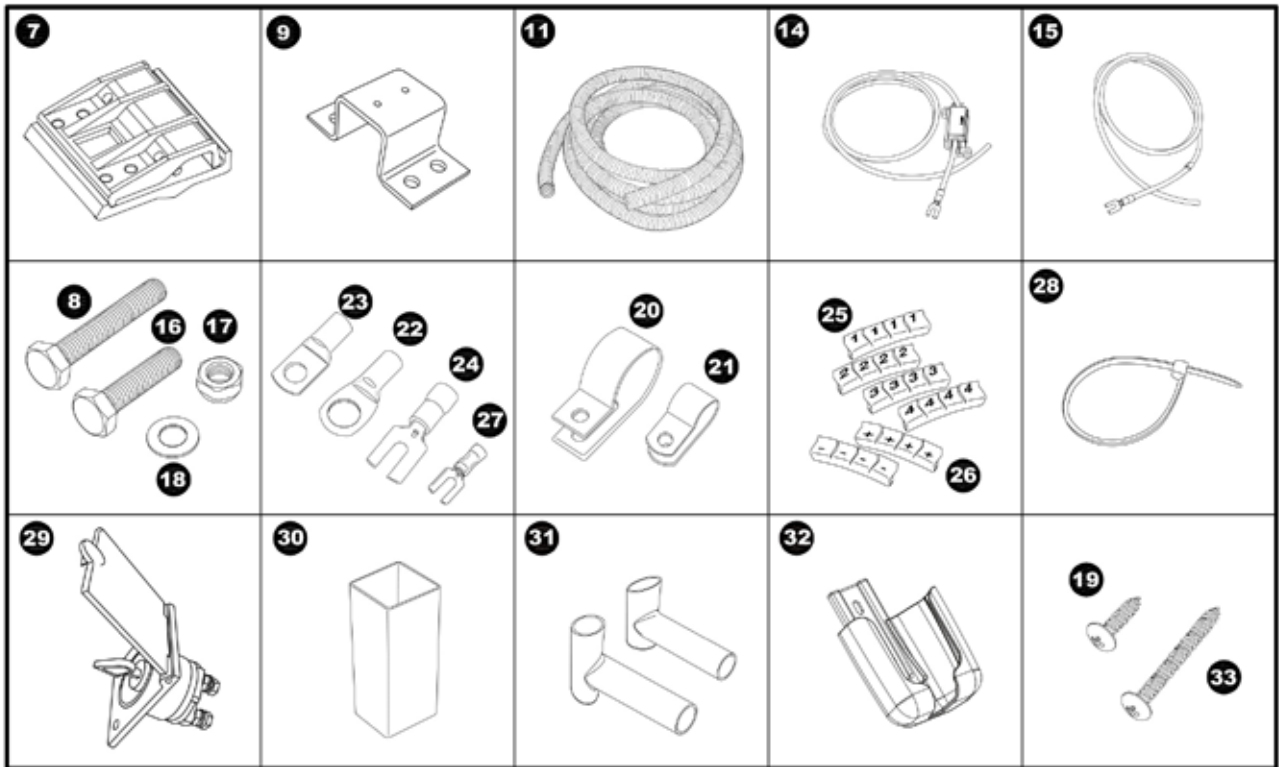
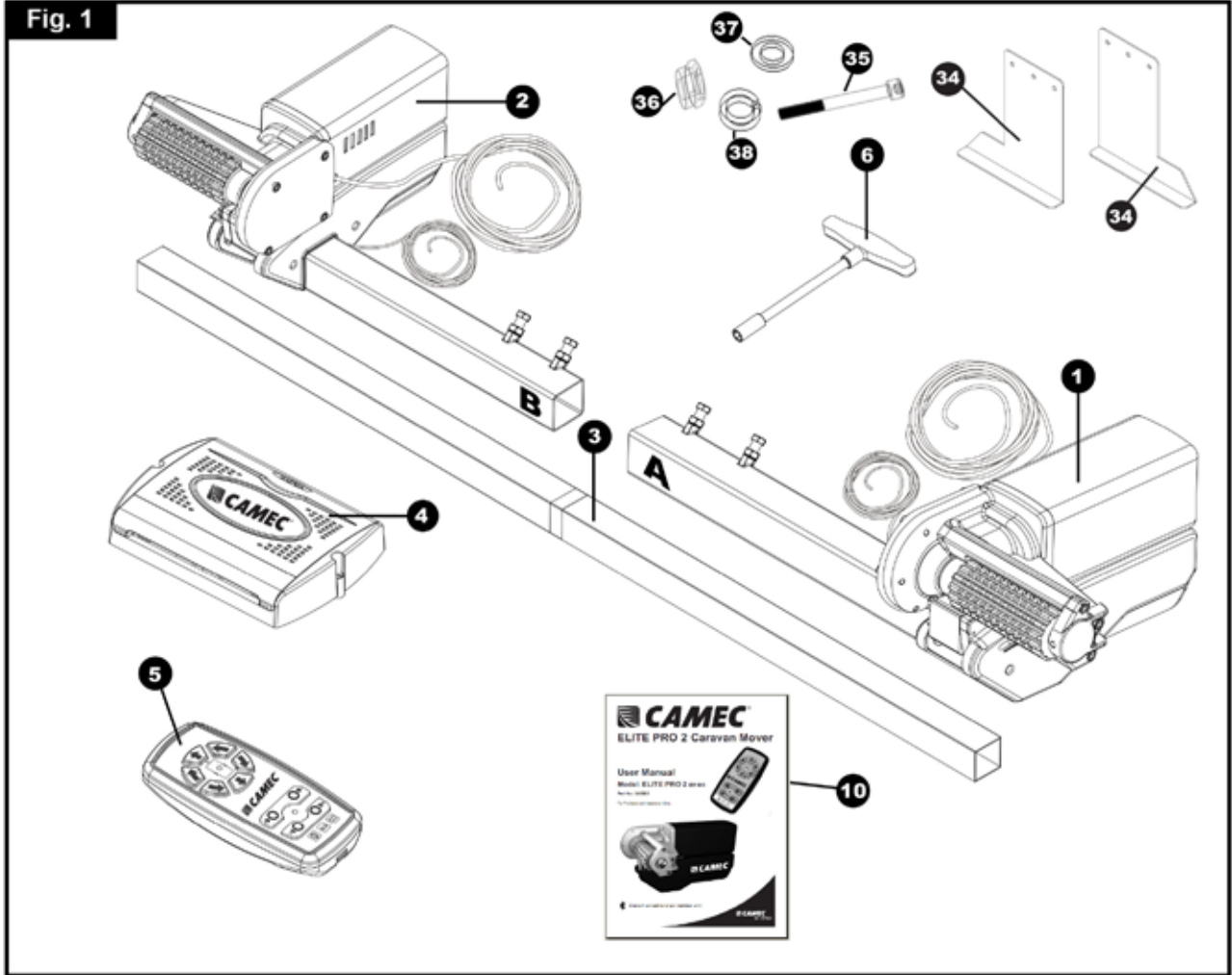

## INTRODUCTION

Congratulations on choosing the **Camec Elite Pro® 2 EM305** caravan manoeuvring system. This has been produced according to very high standards and has undergone careful quality control procedures.

By simply using the remote control handset you can move your caravan effortlessly into any position required within operating guidelines. Soft start and soft stop technology allows you to manoeuvre your caravan accurately without any shocks.

The caravan manoeuvring system consists of two 12V motor-power rollers, a 12V electronic control unit and a remote control handset. To function, the motor-powered rollers must be engaged against the tyres of your caravan. The **Camec Elite Pro® 2 EM305** Caravan manoeuvring system is provided with an automatic engaging system. By pushing two buttons on the remote control, both motor-powered rollers will make contact with the tyre. Once this is done, the manoeuvring system is ready for operation. The remote control will allow you to move your caravan in any direction. You can even rotate the caravan on its own axis, (function not compatible with double axle caravans) without moving forwards or backwards.



**Before proceeding with installation and starting to use the manoeuvring system, please read this manual very carefully and be aware of all the safety instructions! The owner of the caravan will always be responsible for correct use. Keep this manual inside your caravan for future reference.**

## INTENDED USE

The **Camec Elite Pro® 2 EM305** caravan manoeuvring system is suitable for single axle and double axle caravans.

Suitable only for L-profiled and U-profiled chassis with a chassis thickness between min. 2.8mm and max. 3.5mm.

Depending on the weight of the caravan, the manoeuvring system cannot overcome obstructions that are more than about 2cm in height without assistance (please use wedges as a ramp).

The standard installation kit only provides parts for installing the caravan manoeuvring system within the measurements given in Fig. 2.

## SPECIFICATIONS

Designation	<b>Camec Elite Pro® 2 EM305</b>
Operational voltage	12 Volt DC
Average current consumption	30 Ampere
Maximum current consumption	120 Ampere
Speed	approx. 11cm per sec.
Weight (2 motor set)	approx. 33kg (exclusive battery)
Permissible overall Weight single axle (2 motors)	2000kg (1750kg on 18% gradient)
Permissible overall Weight double axle (2 motors)	2000kg (1750kg on 18% gradient)
Permissible overall Weight double axle (4 motors)	3000kg (2350kg on 18% gradient)
Minimum width (caravan/trailer)	1800mm
Maximum width (caravan/trailer)	2500mm
Maximum tyre width	205mm
Power source (battery)	LiFePO <sub>4</sub> : 12V, 20Ah (recommended <b>Camec Elite Pro® 2 EM305</b> ) Lead acid: 12V, 80Ah (min.)

## INSTALLATION - SAFETY GUIDELINES



Read this user manual carefully before installation and use. Failure to comply with these rules could result in serious injury or damage to property.



These symbols identify important safety precautions. They mean **CAUTION! WARNING! SAFETY FIRST! IMPORTANT INFORMATION!**

### Before starting installation under the caravan:

- Check the towing load of your vehicle and the gross weight of your caravan in order to establish whether they are designed for the additional weight. The manoeuvring system itself has a weight of about 33kg and a battery has a weight of about 20-25kg.
- Check the minimal installation dimensions of the manoeuvring system based on figure 2.
- Check that the caravan is disconnected from the battery supply and the mains electrical supply.
- Only use adapters and accessories that are supplied or recommended by the manufacturer.
- Check that the tyres are not worn and do have the same size and design (fitting to new or nearly new tyres is the best option).
- Make sure that the tyre-pressures are correct to the manufacturer's recommendation.
- Make sure the chassis is in good condition without any damage and is free from rust, dirt, etc.
- Stop work immediately if you are in doubt about the assembly or any procedures and consult one of our engineers (please refer to contact information on the last page of this manual).
- Locate the battery isolation switch to be accessible at all times when parking and moving the caravan.
- Do not remove, change or alter any parts of the chassis, axle, suspension or brake mechanism. Any drilling of holes in the chassis is not allowed.
- Do not install the unit if you are under the influence of drugs, alcohol or medication that could impair your ability to use the equipment safely.

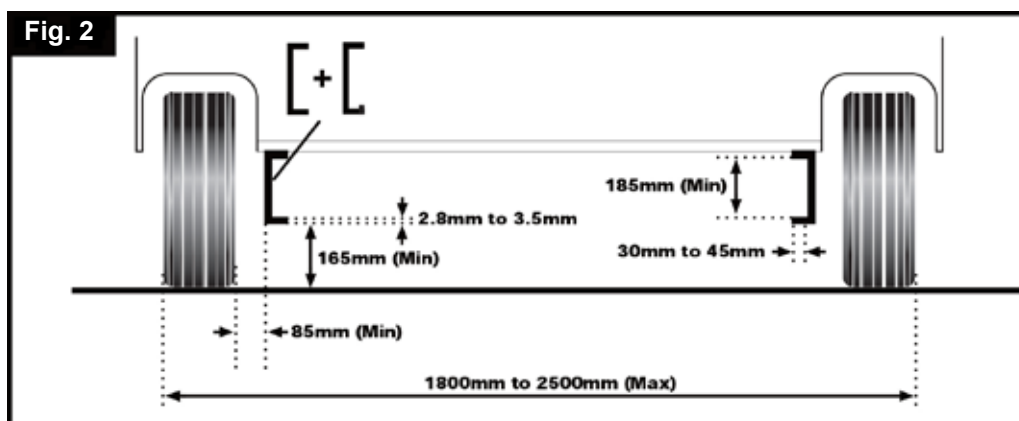

## INSTALLATION - MECHANICAL COMPONENTS



**FOR PROFESSIONAL INSTALLATION ONLY.** These instructions are for general guidance. Installation procedures may vary depending on caravan type.



**Working under a vehicle without appropriate support is extremely dangerous!**

Please refer to Fig. 3 for an overview of the whole assembly fully fitted.

- Place the caravan on a hard, level surface. The use of a lifting ramp or an assembly pit is ideal for access and personal safety.
- Unpack all the components and check for the presence of all parts (see package contents list pg. 2). Write down, on the product warranty registration card, the 10-digit serial number (this is located on an aluminium plate on the side of one of the motor units).
- Clean the area of your chassis where you need to mount all components to ensure a good fitting.
- Make sure the caravan is prepared for installation. Check before installation that important areas, such as drains/spare tyre, etc. do not cause any obstruction to the function of the caravan manoeuvring system.
- Ensure both rollers are in the DISENGAGED position (Fig. 5), as the unit will not fit correctly otherwise (Note: when fully disengaged, the pointer is positioned in the beginning of the yellow area).
- Loosely assemble the left hand motor unit (1), right hand motor unit (2) and main cross bar (3) (Fig. 4). The nuts (Fig. 4A), on the cross bar (3) to secure both motor units, must be no more than finger-tight at this stage.

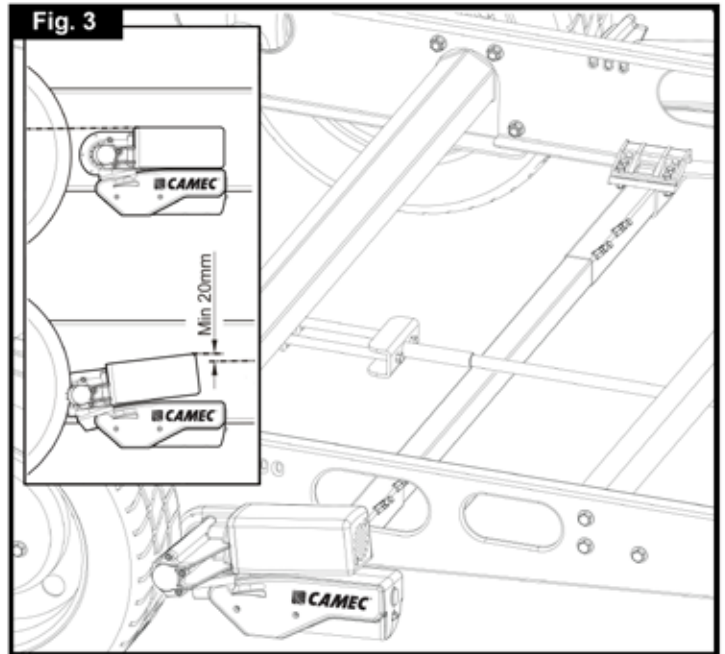

**Note:** In principle, the unit should be fitted in front of the caravan road wheels, but if fitting in this position is not possible because of obstacles or a too high hitch ball weight, it is permissible to fit it to the rear of the wheels by rotating the whole assembly (Fig. 4) by 180° degrees.

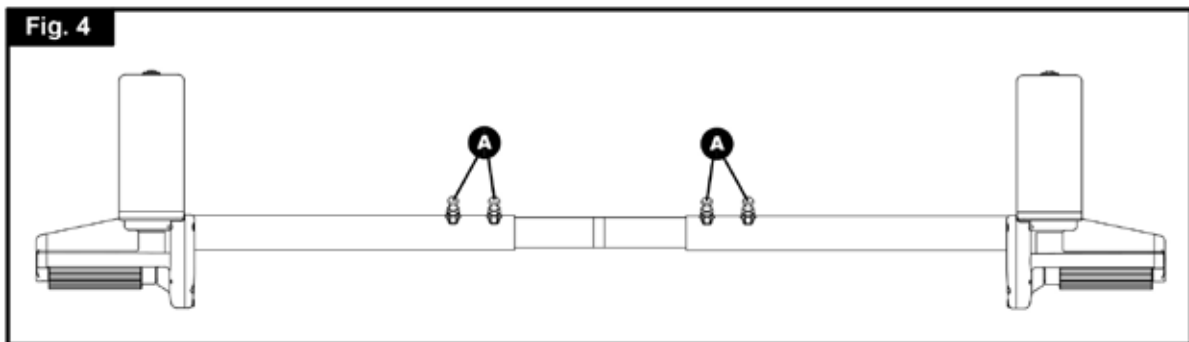

- Fit the Chassis Clamp Plates (34) to the chassis using bolts (35), nuts (36), washers (37) and spring washers (38), then loosely fit the two aluminum clamp plates (7) to the plates (34) (Fig.3 & 6) and attach. Use the bolts M10x60, nuts M10 and washers M10 (8,17,18) and put them in the diagonal positioned holes of the aluminium chassis clamp plates. Nuts must be no more than finger-tight.
- Assemble the pre-mounted manoeuvring system on the aluminium chassis clamp plates by using the two U-shaped brackets (9), bolts M10x50, nuts M10 and washers M10 (16,17,18). Nuts must be no more than finger-tight.
- Make sure that aluminium drive rollers of the motors are approximately on the same altitude as the centre (axle) of the caravan wheel (0mm~40mm, see Fig. 5). As well make sure that between the top of the motor housing and the floor of the caravan is minimal 20mm space to make sure the motors can move freely (see Fig. 3 & 5). To compensate a possible unevenness (and lower the motors), **Camec Elite Pro® 2** has a set of distance plates available. One set can compensate 15mm. In total three sets can be used so that an altitude of 45mm can be compensated.



**Adequate ground clearance:** Please notice that the min. distance between the lowest line of motors and ground is 110mm, no matter what kind of chassis or install situation.

- Make sure that the main cross bar (3) is positioned in the middle of the caravan (the centre of the bar is marked).
- When the main assembly is loosely fitted onto the chassis, slide the whole assembly along the chassis until the rollers are 20mm away from the surface of the centre each tyre (Fig. 5). Two 20mm spacers (30) are provided.

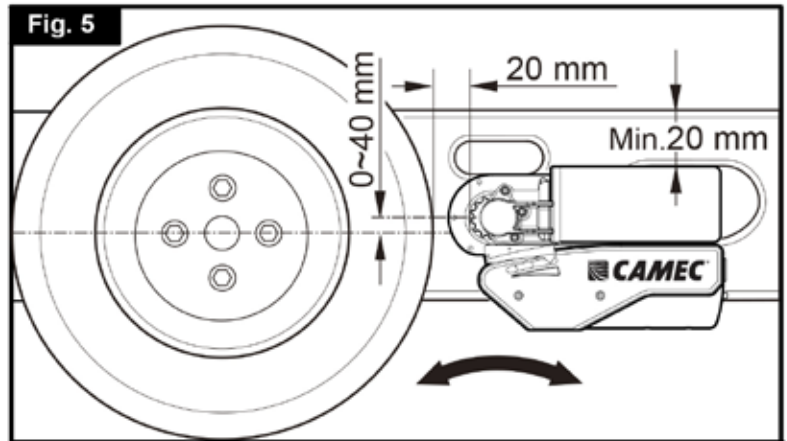

**It is vitally important that each roller is at exactly the same distance away from the tyre. The whole assembly must be parallel to the caravan/trailer axle.**



**Slide the motor units in or out of the cross bar (3) accordingly to ensure the roller will have the maximum possible contact with the tread of the tyre. Ensure that the position of each motor unit does not obstruct shock absorbers (if fitted) and that the gear cover (Fig. 7) is not too close to the surface of the tyre/shock absorber. The minimum clearance when the drive units swivelled in is 10mm.**



**Re-check that there is sufficient space available (minimal 20mm between the top of the motor housing and the floor of the caravan so the motors can move freely (Fig. 3)**

- Fully tighten the four bolts (Fig. 4A) on the main cross bar (3) and lock them by the additional nuts.
- Fully tighten all the nylon nuts on both clamping assemblies (Fig. 6). First tighten the diagonal placed M10x60 bolts with a 20Nm torque, and then M10x50 bolts to a 40Nm torque.
- Re-check the distance of 20mm from the rollers to the tires, the position of the aluminium rollers, the surface of the tyre and finally the distance between the plastic gear cover (Fig. 7) and the tyres & shock absorbers (>10mm). The weight of the caravan must be on the wheels when doing this. If necessary, loosen the bolts and re-adjust the position of the assembly.

The main mechanical components have now been installed.

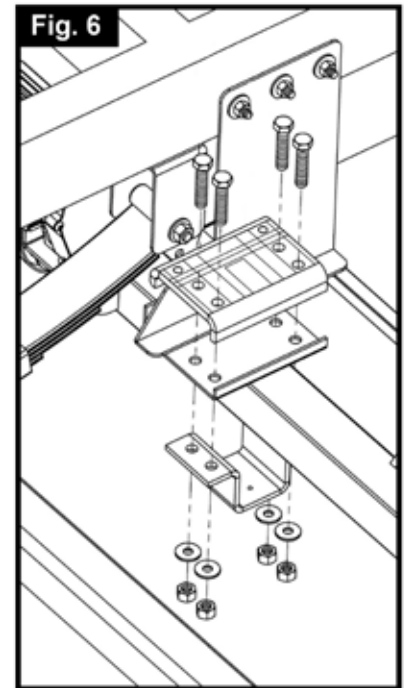
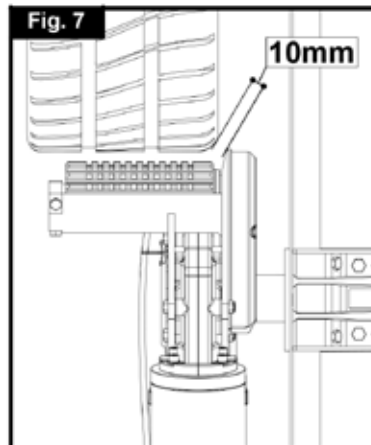

**Re-check that all bolts/nuts have been tightened to the correct torque!**

## INSTALLATION - ELECTRICAL/ELECTRONIC COMPONENTS



**Make sure the 12V supply from the battery and any 240V electricity supply are disconnected.**

- Remove battery cable terminals and disconnect any external electrical power before starting work.
- Find a suitable place for the electronic control unit (4), such as a storage area, under a seat or a bed. Make sure this place is dry and close to the battery (40cm to 60cm). The electronic control unit can be mounted vertically on a side wall or be mounted flat. When mounted vertically, the connections must point downwards to avoid any short-circuits by objects falling into it.
- Fix the electronic control unit securely into position with two screws M5x40 (33). **Note:** if the provided screws are not of suitable length or type for the desired location/material please substitute these as appropriate.
- Drill a 25mm hole through the floor of the caravan approximately 150mm centrally in front of the control unit (4) terminals.



**Caution! Take extra care to avoid any chassis members, gas pipes and electrical wires!**

- Route and connect the motor-cables in accordance with wiring diagram (Fig. 8) (red = positive, black = negative).

The wiring diagram (Fig. 8 + Table. A) below depicts the wiring route when installing the motor units in front of the wheels/axle towards the 'A' frame.

Please refer to Table B (below) for fitment of the motor units to the rear of the axle.

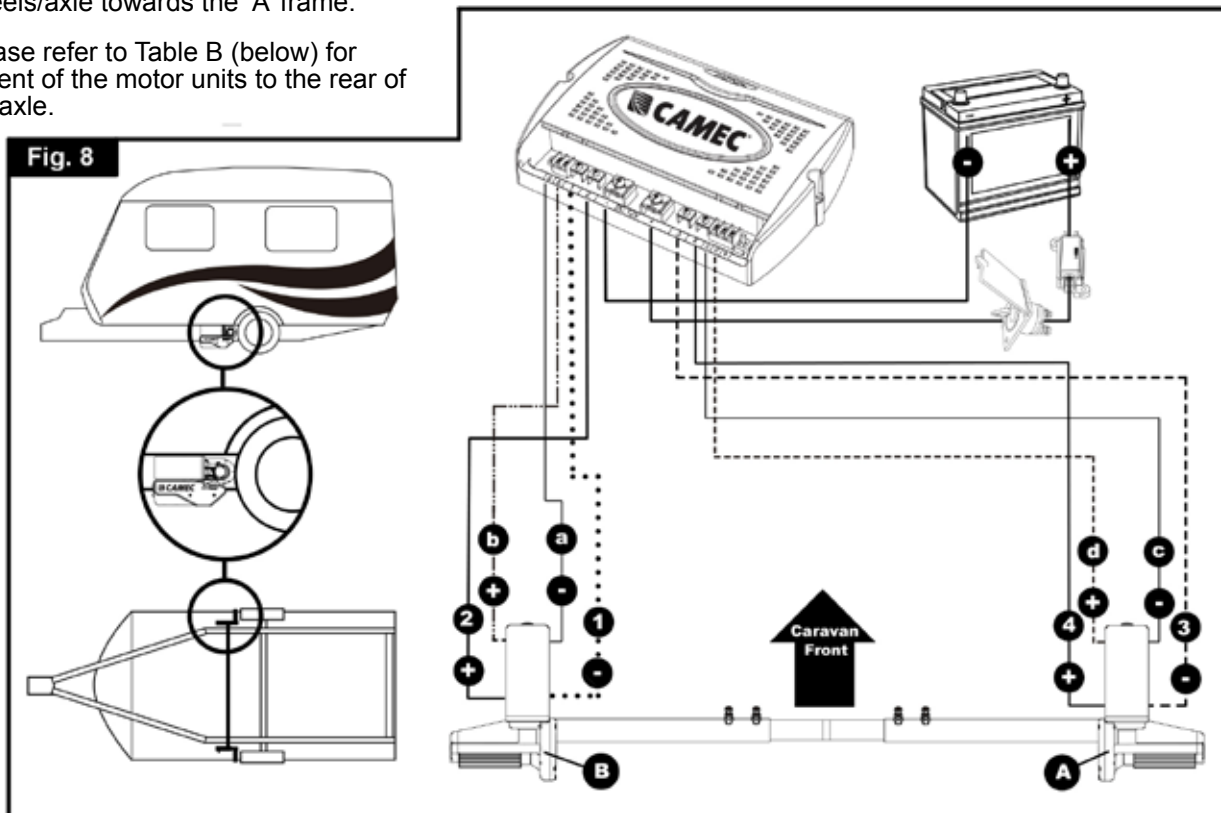

Table A	Table B
<b>FRONT OF AXLE FITTING</b>	<b>REAR OF AXLE FITTING</b>
(4,6mm <sup>2</sup> cables)	(4,6mm <sup>2</sup> cables)
Motor unit A Positive (+) cable to terminal 4	Motor A Positive (+) cable to terminal 1
Motor unit A Negative (-) cable to terminal 3	Motor A Negative (-) cable to terminal 2
Motor unit B Positive (+) cable to terminal 2	Motor B Positive (+) cable to terminal 3
Motor unit B Negative (-) cable to terminal 1	Motor B Negative (-) cable to terminal 4
Automatic engaging system (1,5mm <sup>2</sup> cables):	Automatic engaging system (1,5mm <sup>2</sup> cables):
Motor unit A: Positive (+) cable to terminal d	Motor unit A: Positive (+) cable to terminal b
Motor unit A: Negative (-) cable to terminal c	Motor unit A: Negative (-) cable to terminal a
Motor unit B: Positive (+) cable to terminal b	Motor unit B: Positive (+) cable to terminal d
Motor unit B: Negative (-) cable to terminal a	Motor unit B: Negative (-) cable to terminal c



- Mark the motor cables for both motor units using the cable markers (25). The cables for the left and the right motor should have the same length. Avoid any loops.

Remember to leave a small amount of slack cable near the motors to allow for their movement when the drive rollers are engaged.

- Route all the cables along the underside of the caravan floor, inside the supplied convoluted trunking (11) (this will protect the electrical cables against sharp edges and dirt) and through the drilled hole.
- Secure the cable trunking (11) to the chassis or under body of the caravan by using the P-Clips (20) and screws (19).
- Once the all cables are through the drilled hole next to the control unit (4), cut the cables, ensuring that they are the same length. Remove approx. 5mm of the insulation from the ends. Fix the big spade fork connectors (24) to the motor cables and the small spade fork connectors (27) to the automatic-engaging-cables by using crimping pliers. A secure and good quality connection on each cable is essential.
- Attach the spade fork connectors to the terminals on the control unit (see wiring diagram Fig. 8) and fix them tightly by the screws. A safe and good quality connection on each cable is again essential.
- Find a suitable place for the battery power isolation switch (29) which includes an external holder with hinged cover. **Important: The switch must be mounted onto the exterior body of the caravan and be easily accessible from the outside of the caravan in case of any emergency.** The switch must be mounted close to the location of the battery in order to keep the length of the battery cables to a minimum.
- Use the cardboard template to position the hole positions and the drill holes. Mount the switch and the housing with the bolts, washers and nuts, and finally mount it on the caravan with stainless steel screws (19).
- Route the positive (+) power cable (including fuse) from the battery to the battery power isolation switch (29) and than further to the control unit (4).

The electronic connections of the battery power isolation switch (29) must be covered by the supplied rubber isolation shells (31).

- Route the negative (-) power cable directly to the control unit (4).



**No cables may be routed over the control unit!**

Again it is recommended to use the supplied trunking (11) to protect the cables against sharp edges.

- Attach the trunking with P-clips (20) and P-clip screws (19).
- Cut the cables to an appropriate length and remove approx. 5mm of the insulation from the ends. Fix the battery terminal connectors by using crimping pliers. Two types of battery terminal connector (22 & 23) are provided for use as appropriate. A secure and good quality connection on each cable is essential.
- Connect the battery cables (14 & 15) to the control unit (4): Attach the spade fork connectors to the positive (+) and negative (-) terminal of the control box and fix them tightly by the screws.
- Connect the battery cables to the existing battery terminals (red = positive, black = negative).



**Caution! Make sure that you do not reverse the Positive (+) and Negative (-) connections. Incorrect connection (reverse polarity) will result in damage to the control unit.**

- Seal the 25mm hole in vehicle under body using plastic body sealant.
- Finally find a suitable place for the remote control handset wall holder (32) and fix this by the supplied screws (out of reach of children or other unauthorised people).

Installation of the caravan manoeuvring system is now complete.

## INSTALLATION - TWIN AXLE

When you use the manoeuvring system for a twin axle caravan, please check the following:

Permissible overall weight twin axle (2 motors) 2000kg (1750kg on 18% gradient)  
 Permissible overall weight twin axle (4 motors) 3000kg (2350kg on 18% gradient)

### 2 motors:

The procedure for installing a 2 motors manoeuvring system on a twin axle caravan is the same as for a single axle caravan. The electronic control unit (4) only must be prepared for twin axle use. Turn off the battery power isolation switch and move the single/twin axle function switch (Fig 9S/T) on the control unit to the twin axle position (Fig. 9T), so that the manoeuvring system can be used for a twin axle caravan. In the twin axle function when making curves, all wheels will drive, but at a different speed.

### 4 motors:

The procedure for installing a 4 motors manoeuvring system on a twin axle caravan is similar than for a single axle caravan, but then with two sets of manoeuvring systems.

Follow the procedure **INSTALLATION - MECHANICAL COMPONENTS** twice: one time for the manoeuvring set mounted in front of the twin axle and one time for the manoeuvring set mounted behind the twin axle.

Follow the procedure **INSTALLATION - ELECTRICAL/ELECTRONIC COMPONENTS** twice: one time for the manoeuvring set mounted in front of the twin axle and one time for the manoeuvring set mounted behind the twin axle (see wiring diagram pg. 11).

**Note:** When installing the four motors it will be necessary to use **one** higher capacity battery to supply both sets of manoeuvring systems (including two electronic control units and two battery power isolation switches). Do not use two separate batteries for a 4 motors manoeuvring system on a twin axle caravan.

Now **both** electronic control units (4) must be prepared for twin axle use:

- Turn off the battery power isolation switch and move the single/twin axle function switch (Fig 9S/T) on the control unit to the twin axle position (Fig. 9T), so that the manoeuvring system can be used for a twin axle caravan. In the twin axle function when making curves, all wheels will drive, but at a different speed.

Finally both electronic control units (4) must be prepared for the use of only one remote handset (32). The remote handset needs to be synchronised with both electronic control units using the following procedure:

- Check the installation in accordance with the installation instructions and ensure that the drive rollers are not applied. Check that the battery is properly connected, check the condition of the battery and that a voltage of 12V is present at the control unit.
- Please ensure that both battery isolation switches are on.
- Activate the remote control handset by sliding the slide switch to "On"-I (Fig. 10A). The green LED on the remote control handset (Fig. 10H) will start to flash slowly.
- Press the reset button (Fig. 9A) on the control unit. All three LED's on the control unit (Fig. 9B, 9C & 9D) will flash slowly.
- Press both forwards (Fig. 10B) and reverse (Fig. 10C) button on the remote control handset for about 3 seconds. The handset buzzer will give a short beep to confirm that the synchronisation is complete.
- After successful synchronisation, the green LED on the control unit (Fig. 9B) and on the remote control handset (Fig. 10H) will illuminate continuously.
- Repeat this procedure with the second electronic control unit.
- Turn the remote handset "Off" and then "On" again so both control units will be activated.

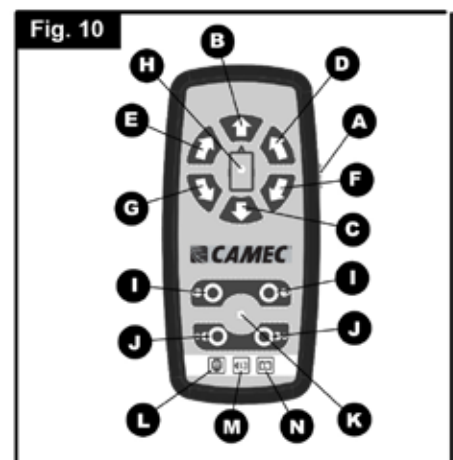
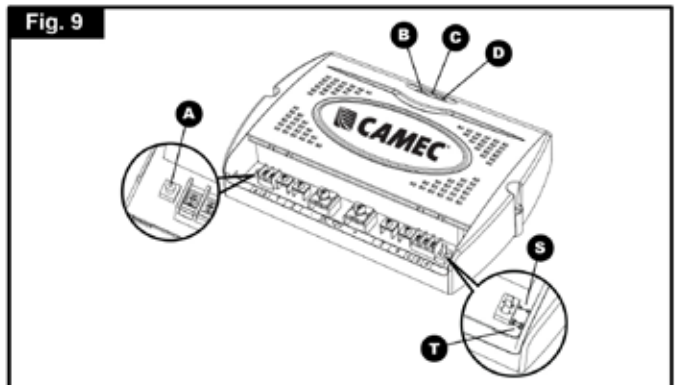

The installation of the caravan manoeuvring system for twin axle use is now complete. For details of the operation, use and all the LED and button functions, please refer to the table of contents.

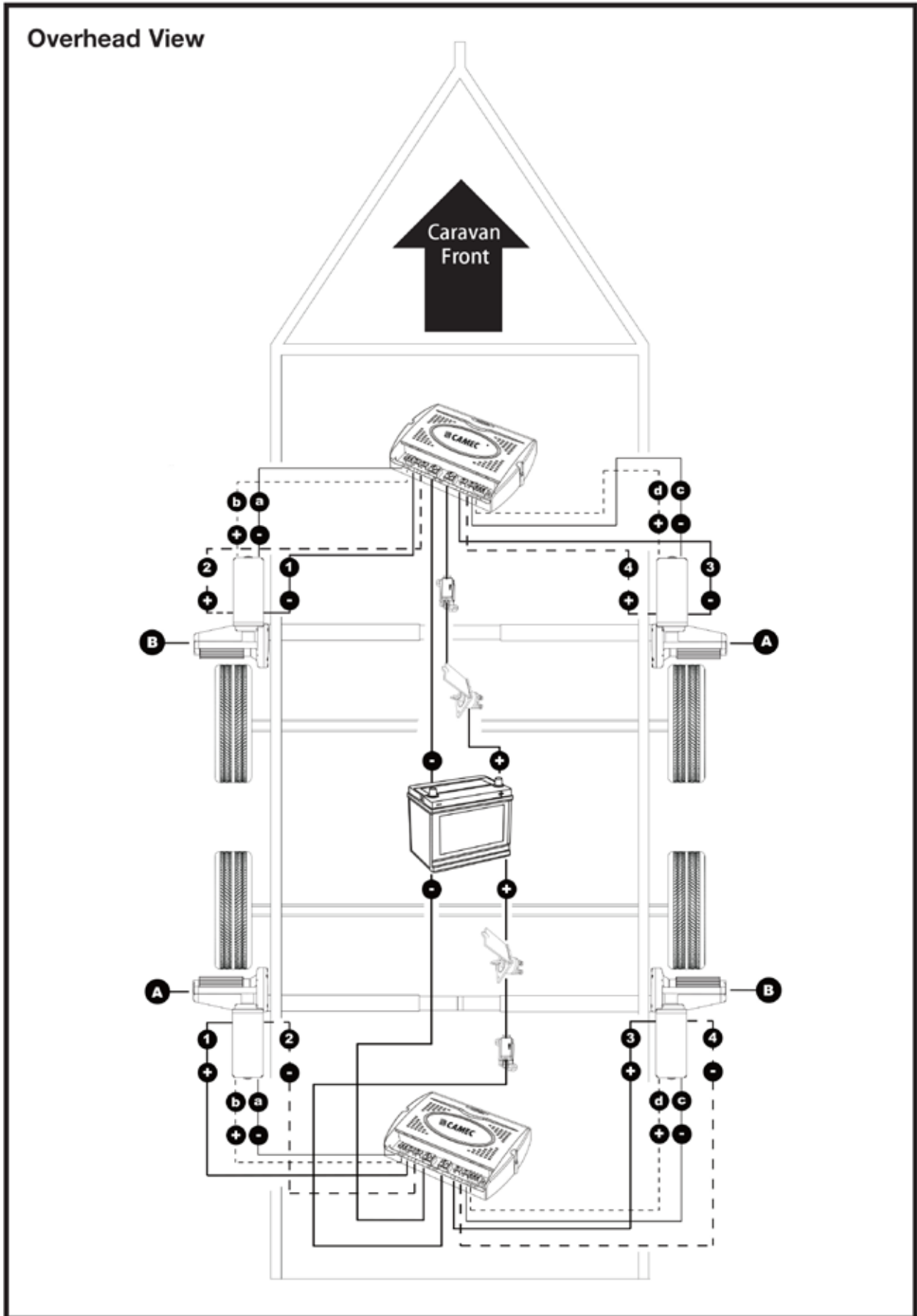

## OPERATION - SAFETY GUIDELINES

Practice operating the manoeuvring system in an open area before using for the first time to fully familiarise yourself with the handset and manoeuvring system operation.



Before use, always check the caravan manoeuvring system for any damage.



When towing or moving the caravan please be aware, at all times, that ground clearance is reduced when the manoeuvring system has been fitted.



Always ensure that children and pets are kept well out of the way during operation.



When operating the system, ensure that no hair, fingers or other body parts, clothing or any other objects carried on the body can become trapped by moving or rotating parts (e.g. drive rollers).



In the event of malfunctions, pull on the handbrake immediately and turn off the main isolation power switch.



To maintain signal strength, always make sure that, during manoeuvring, the distance between the remote control and the caravan does not exceed 5 metres.



Due to the nature of a radio signal, it can get corrupted by external terrain or objects. So there may be small areas around the caravan where the quality of reception reduces, hence the manoeuvring system may stop momentarily.



Always be aware that the manoeuvring system increases the weight of your caravan or trailer. So this reduces the payload of the caravan.



Do not exceed the total safe working load of 2000kg laden weight (caravan including load) when 2 motors are used and 3000kg laden weight (caravan including load) when 4 motors (twin axle) are used.



Always make sure that the rollers are fully disengaged from the tyres when the manoeuvring system is not in use. This is better for the tyres and for the system.



Always make sure that the rollers are fully disengaged before towing/moving the caravan by vehicle or manpower. This can damage the tyres, manoeuvring system and the towing vehicle.



Always make sure that after you have finished using the manoeuvring system, the battery power isolation switch (29) is switched off and the key is removed and stored in a safe place (out of reach of children or other unauthorised people). If you don't switch off, the battery will be discharged by the small "standby" current.



Always make sure that the remote control handset is switched off and stored (in the wall holder) in a safe place (out of reach of children or other unauthorised people). If you don't switch off, the battery will be discharged by the small "standby" current.



Do not rely on the manoeuvring system to act as a brake.



Always apply the handbrake after manoeuvring, before disengaging the drive rollers from the tyres.



Do not use the manoeuvring system as a support when jacking up the caravan, since this can damage the drive unit.



Depending on the weight of the caravan, the manoeuvring system cannot overcome all obstructions without assistance. Please use wedges as a ramp.



All wheels and tyres on the caravan must be of the same size and design. If tyres are worn or new tyres are fitted, the distance between the drive rollers and the tyres may need readjusting (see "Installation - Mechanical Components").



Sensitive objects such as cameras, DVD-Players etc. must not be kept in the stowage box near the control unit or the motor cable. They can be damaged by the electromagnetic fields.



Do not make any modifications on the caravan manoeuvring system (mechanical or electronically). This can be very dangerous! No warranty claim will be accepted and we cannot guarantee the function of the system if any modifications are made. We will not be liable for any damage whatsoever caused as a result of incorrect installation, operation or modification.

## OPERATION - MOTOR UNITS

The manoeuvring system has two motor units (1 & 2). In general they are mounted in front of the axle of the caravan. Both units are identical but cannot be switched.

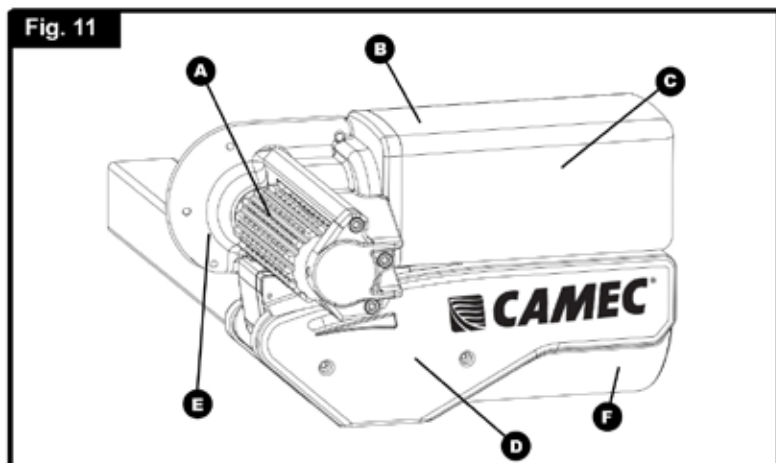

A.	Aluminium drive roller
B.	Drive unit, including 12V motor
C.	Plastic motor cover
D.	Base unit
E.	Gear cover
F.	Motor for automatic engaging system

### Traction indicator label:

The yellow-green-red traction indicator label (Fig. 12A), on the side of each motor unit indicates if the roller is depressing the tyre sufficiently to provide adequate traction.

If the pointer is in the <b>YELLOW</b> area	Rollers are not touching or depressing the tyre sufficiently
If the pointer is in the <b>GREEN</b> area	Rollers should be connecting correctly to the tyre (margin of 15mm)
If the pointer is in the <b>RED</b> area	Rollers are connected to the tyre but in an extreme position. It could be that the tyre of the caravan has insufficient air pressure or the drive unit has been knocked out of position and a visit to a workshop is required to reposition the assembly

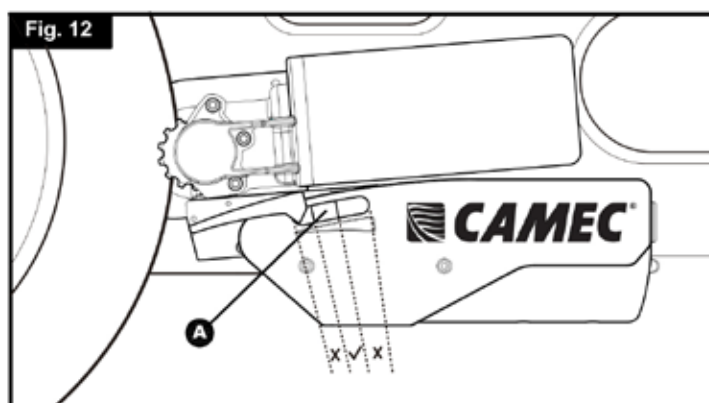

### Disconnect the motor powered rollers in case of emergency:

In the case that the caravan battery is discharged too far to automatically take the motor powered rollers off the tyre, or there is a defect, you can also do this manually. See figures 13 & 13.1.

- Take the plastic cap (Fig. 13B) at the rear side of the housing off the motor for the automatic engaging system. If necessary use a screwdriver.
- Place the emergency key (6) on the emergency socket in the motor unit (Fig. 13A & 13.1C) and turn it until the motor unit including motor powered rollers are in the beginning position.
- Repeat this also on the motor unit on the other side.
- Put the plastic caps back on the motor housing.

As soon as the battery is charged again, or the problem is solved, the motor powered rollers will automatically work again.

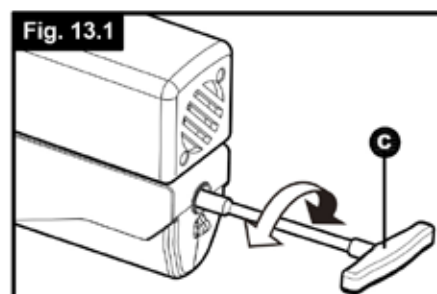
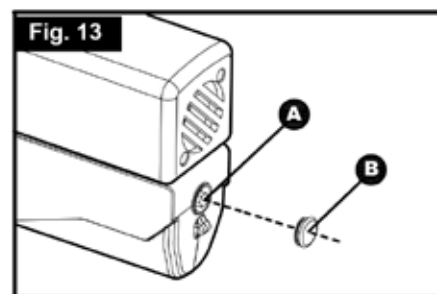

## OPERATION - REMOTE CONTROL HANDSET

The remote control handset (5) is powered by one PP3 9 Volt battery, and is activated by moving the slide switch to “On”-I (Fig. 14A). Once activated, the green LED (Fig. 14H) will illuminate and the directional controls can now be used.

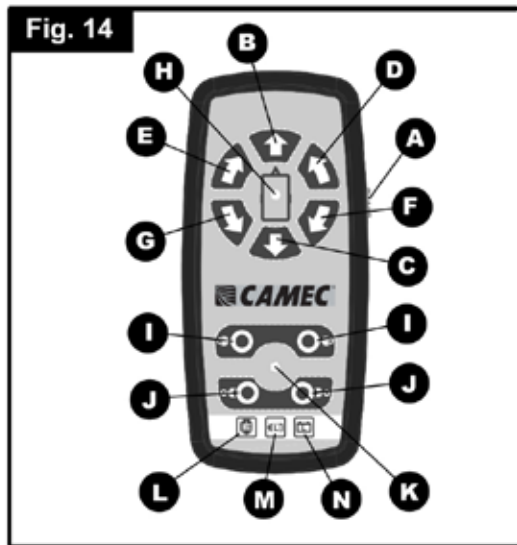

A.	Slide switch (“Off” –O and “On”-I)
B.	Caravan forwards (both wheels rotate in forwards direction)
C.	Caravan reverse (both wheels rotate in reverse direction)
D.	Caravan left forwards (right wheel rotates in forwards direction)
E.	Caravan right forwards (left wheel rotates in forwards direction)
F.	Caravan left reverse (right wheel rotates in reverse direction)
G.	Caravan right reverse (left wheel rotates in reverse direction)
H.	Green LED: reflects status of the remote control and caravan manoeuvring system
I.	Two handed service for automatic engaging of the motor powered rollers to the tyre
J.	Two handed service for automatic disengaging of the motor powered rollers from the tyre
K.	Blue LED: reflects status of the automatic engaging system
L.	Red overload LED: Amp overload protection is activated. Wait about 60 seconds and try again
M.	Blue 9V battery LED: The internal 9V battery of handset is near empty and needs to be replaced
N.	Blue battery voltage LED: Caravan battery voltage too low or too high

When you drive straight forwards or reverse (press button B or C), it is also possible to adjust the direction by additionally pressing button D or E (when driving forwards), or button F or G (when driving reverse).

In addition, the ‘right forward’ (E) and ‘left reverse’ (F) buttons or ‘left forward’ (D) and ‘right reverse’ (G) buttons may be pressed at the same time to turn the caravan around on its own axis without moving forward or backward.

When you switch within 2 seconds from forward driving to reverse driving (and the other way around), a small delay of 1 second will occur to protect the electronics and the motors.



**The slide switch (Fig. 14A) also acts as an “Emergency stop”.**

### The automatic engaging system:

To activate the automatic engaging system of the motor powered rollers on the tyre, press the two buttons for engaging (Fig. 14I) or disengaging (Fig. 14J) for at least three seconds. The blue LED (Fig. 14K) will blink fast during these three seconds and every second there will be a beep. This warns you that the system will be activated!

**Engaging:** After these three seconds, the motor powered rollers will be pressed against the tyre and the blue LED will illuminate constantly. Now you can release the two buttons. When the motor powered rollers are pressed on the tyre strongly enough, you will hear a short beep. The blue LED will switch off and the system is ready to use.

**Disengaging:** After these three seconds, the motor powered rollers will be released from the tyre and the blue LED will illuminate constantly. Now you can release the two buttons. When the motor powered rollers are completely disengaged, you hear a short beep. The blue LED will switch off and the caravan is ready for transport or use.

### The remote hand set switches off:

- After 3 minutes, if no button is pressed: After 2 minutes the buzzer will beep 5 times with a repetition after 3 minutes. Then the system switches to “stand-by” mode.
- After 6 minutes, if one of the movement buttons is permanently held down: After 5 minutes the buzzer will beep 5 times with a repetition after 6 minutes. Then the system switches to “stand-by” mode.

When the remote handset is in “stand-by” mode, it may still draw some current. Be sure to slide the switch to “Off” –O to preserve the battery. To reactivate the remote control, move the slide switch to “Off” –O and then back to “On” –I after approximately 1 second.

#### Error messages via the remote control handset:

Error messages of the **Camec Elite Pro® 2 EM305** will be communicated via the remote control handset by the green LED (Fig. 14H), the error message LED's (Fig. 14L, 14M & 14N) and a buzzer signal.

Green LED (Fig. 14H) off, no buzzer:	Remote control handset is turned off and also system is not activated.
Green LED (Fig. 14H) continue on, no buzzer:	Remote control handset is turned on and system is active and ready to use.
Green LED (Fig. 14H) is blinking, no buzzer:	No communication between handset and control unit. This could be because of too much distance between remote control handset and control unit, the battery isolation switch for manoeuvring system is not turned on, or that there is a distortion signal disturbing the communication. As soon as connection is good again the green LED will be continue on and the system is ready to use.
Blue battery voltage LED (Fig. 14N) is blinking in combination with buzzer (2 times blinking, break, 2 times blinking, break etc.):	Battery voltage too low (<10V). Battery needs to be recharged.
Blue battery voltage LED (Fig. 14N) is blinking in combination with buzzer (4 times blinking, break, 4 times blinking, break etc.):	Battery voltage too high (over charged). Try to discharge the battery by turning on an appliance (for example a lamp or water-pump).
Red overload LED (Fig. 14L) is blinking in combination with buzzer (6 times blinking, break, 6 times blinking, break etc.):	Amp overload protection is activated. Wait about 60 seconds and try again.
Blue 9V battery LED (Fig. 14M) is blinking, no buzzer:	The internal 9V battery is near empty and needs to be replaced.

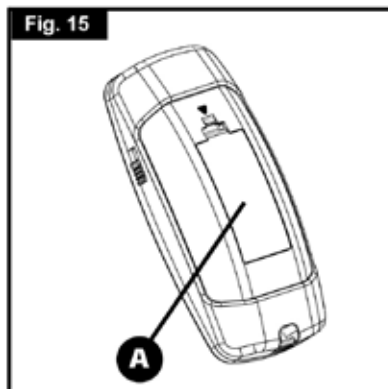

#### Changing batteries in the remote control:

When the battery is empty (blue 9V battery LED (Fig. 14M) is blinking), it needs to be replaced.

- Open the rear cover of the handset (Fig. 15A).
- Take out the dead/old battery and dispose in the appropriate way.
- Install a new replacement battery (Fig. 15.1). Make sure to use a leak proof PP3 (9Volt) battery (No claims under guarantee can be considered for damage caused by leaking batteries).
- Close the rear cover again.



**Dead and used batteries may leak and damage the remote control handset! Remove the batteries if the handset is not going to be used for an extended period.**

## OPERATION - ELECTRONIC CONTROL UNIT

The electronic control unit (4), which is mounted inside your caravan, is responsible for controlling the manoeuvring system.

The control unit has three LED's, one push button and one slide switch (Fig. 16):

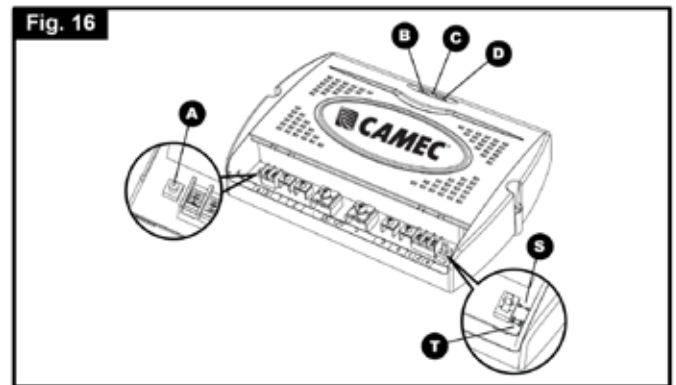

<b>Green LED</b> (Fig. 16B)	Power LED continuously illuminated when system is activated (by moving slide switch to "On"-I).	If the handset is far away from the control unit, beyond the connection distance, this LED will go out.
<b>Blue LED</b> (Fig. 16C) Error message LED concerning caravan battery	Blue LED is blinking (2 times blinking, break, 2 times blinking, break, etc.)	Battery voltage too low (<10V). Battery needs to be recharged.
	Blue LED is blinking (4 times blinking, break, 4 times blinking, break, etc.)	Battery voltage too high (over charged). Try to discharge the battery by turning on an appliance (e.g. a lamp or water-pump).
<b>Red LED</b> (Fig. 16D)	Red LED is blinking (6 times blinking, break, 6 times blinking, break, etc.):	Amp overload protection is activated. Wait about 60 seconds and try again.

In general all error messages will reset automatically after one minute. If this is not the case, reset the electronics of the manoeuvring system by switching off the system via the isolation switch and the remote control handset for at least 15 seconds and then turning it on again.

**The Reset Button** (Fig. 16A): The remote control handset and the control unit are synchronised with each other in the factory. If the control unit or the remote control handset is replaced, they must be re-synchronised as described below:

- Check the installation in accordance with the installation instructions and ensure that the drive rollers are not applied. Check that the battery is properly connected, check the condition of the battery and that a voltage of 12V is present at the control unit.
- Please ensure that the battery isolation switch is on.
- Activate the remote control handset by sliding the slide switch to "On"-I (Fig. 17A). The green LED on the remote control handset (Fig. 4H) will start to flash slowly.
- Press the reset button (Fig. 16A) on the control unit. All three LED's on the control unit (Fig. 16B, 16C & 16D) will flash slowly.
- Press both the forwards (Fig. 17B) and reverse (Fig. 17C) button on the remote control handset for about 3 seconds. The handset buzzer will give a short beep to confirm that the synchronisation is complete.
- After successful synchronisation, the green LED on the control unit (Fig. 16B) and on the remote control handset (Fig. 17H) will illuminate continuously.

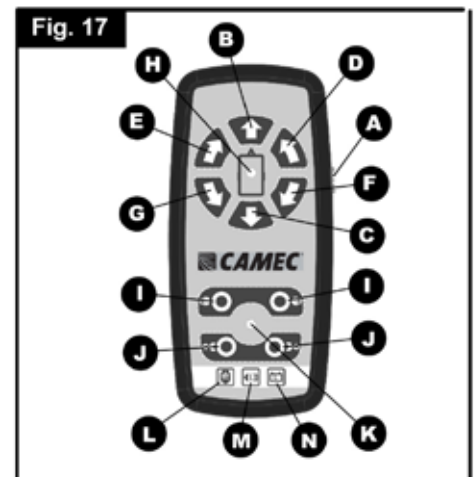

**The single-twin axle function switch** (Fig. 16S/T): The **Camec Elite Pro® 2 EM305** caravan manoeuvring system is suitable for both single axle and twin axle caravans. You just need to move the single-twin axle function switch (Fig. 16S/T) on the control unit, so that the manoeuvring system can be used for a single-axle caravan or a twin-axle caravan (for 2 motor use but also for 4 motor use). In the twin axle function, all wheels will drive, but at a different speed.

**The switch is pre-selected for single axle use** (Fig. 16S): For twin axle use, just move the switch to the twin axle position (Fig. 16T). When moving the single-twin axle function switch, the battery power isolation switch (29) must be turned off.



## OPERATION - GETTING STARTED



Please make sure you read the safety instructions very carefully and follow these guidelines!



Make sure that the battery that supplies the system is fully charged and in good condition.



Make sure that the caravan is free from the vehicle and the handbrake is on. Also make sure that the corner steady feet are fully raised.

- Turn on the battery power isolation switch (29).
- Activate the manoeuvring system by moving the slide switch to “On”-I on the remote control (Fig. 18A). The green LED (Fig. 18H) on the remote control handset will illuminate and you will hear a short beep. The remote control is ready for use.
- To activate the system press the two (Fig. 18I) buttons for three seconds. The blue LED (Fig. 4H) will blink fast during these three seconds and every second there will be a beep. This warns you that the system will be activated!
- After these three seconds the motor powered rollers will be pressed against the tyre and the blue LED will illuminate constantly. Now you can release the two buttons. When the motor powered rollers are pressed on the tyre strongly enough, the blue LED will switch off and the system is ready to manoeuvre. The colour of the traction indicator label (Fig. 19A) should be in the green area.
- Before operating the manoeuvring system, release the handbrake.

Now you can choose the movements according to the symbols shown on the remote control (Fig. 18)

In addition, the left forward (Fig. 18D) and right reverse (Fig. 18G) buttons or right forward (Fig. 18E) and left reverse (Fig. 18F) buttons may be pressed at the same time to turn the caravan around on its own axis without moving forward or backward. When you drive straight forwards or reverse (press button 18B or 18C), it is also possible to adjust the direction by additionally pressing button 18D or 18E (when driving forwards) or button 18F or 18G (when driving reverse).

Because of the “soft start” technology, the caravan will slowly speed up. Because of the “soft stop” technology, the caravan will stop slowly. This allows you to manoeuvre your caravan even more accurately without any shocks.



**WARNING:** When the buttons on the remote control handset are released, the caravan will slowly stop after 0.5 second and continue to move about 6cm (depending on final speed). If the buttons of the remote control handset are released when the system is still in the “soft start” stage (slowly speed up), the caravan will stop immediately.

After the “soft start” stage the caravan moves accordingly one fixed speed. The speed can increase a little when going downhill and decrease a little when going uphill. **TIP:** The manoeuvring system is more efficient when reversing the caravan up an incline.



**When the caravan is in position, you need to secure the handbrake. To deactivate the system, press the two buttons (18J) for three seconds.**

- Press the two disengaging buttons for at least 3 seconds to disengage the motor powered rollers (Fig. 18J). The blue LED (Fig. 18H) will blink fast during these three seconds and every second there will be a beep. This warns you that the system will be activated!
- After these three seconds the motor powered rollers will be released from the tyre and the blue LED will illuminate constantly. Now you can release the two buttons. When the motor powered rollers are completely disengaged the blue LED will switch off and the system is ready for transport.
- After manoeuvring, deactivate the manoeuvring system by moving the slide switch to “Off”-O on the remote control handset (Fig. 18A). The green LED (Fig. 18H) on the remote control handset will turn off. Store the remote control in a safe place (out of reach of children or other unauthorised people).
- Turn off the battery power isolation switch.



**Before you start driving always make sure that the both drive units are fully disengaged!**

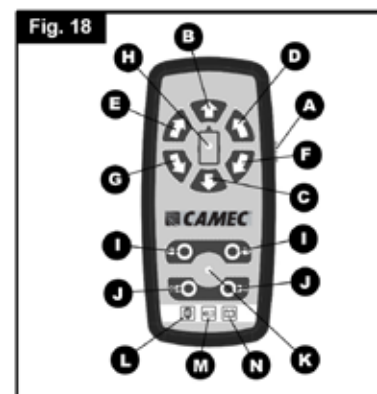

Straight forward (18B)

Straight reverse (18C)

Left forward (18D)

Left reverse (18F)

Right forward (18E)

Right reverse (18G)

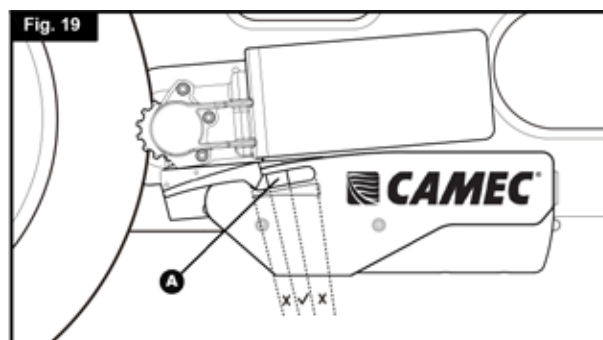

## OPERATION - HITCHING AND UNHITCHING

It is possible to position the caravan's hitch exactly over a stationary car's tow ball using the manoeuvring system. But please be very careful!

Use the button controls on the remote control to bring the hitch of the caravan to the car. The soft start technology allows you to locate the tow-ball of the car by centimetre. It is better reach the tow ball with several short "trips" rather than trying to do it in one "trip".



**WARNING: When the buttons on the remote control handset are released, the caravan will slowly stop after 0.5 second and continue to move about 6cm (depending on final speed). If the buttons of the remote control handset are released when the system is still in the "soft start" stage (slowly speed up), the caravan will stop immediately.**

When the hitch is right above the tow ball of the vehicle, lower the hitch to the ball and engage in the normal way using the jockey wheel.



**Release the rollers from the caravan's tyres. You cannot tow the caravan with the drive units are engaged! Before you start driving always make sure that the both drive units are fully disengaged!**



**Trying to drive away with the drive units still engaged, will damage the manoeuvring system, your caravan tyres and strain your tow vehicle!**

## MAINTENANCE

- To prevent the battery from becoming totally discharged during long periods of inactivity it must be disconnected, fully charged and frost-proof stored.
- Please check regularly that the rollers of the drive units are free of any dirt, or debris that may have been picked up from the road.
- Regularly clean the drive units with a water hose to dissolve mud, etc.
- Please check regularly the distance between the rollers and the tyres. In the neutral (fully disengaged) position, this must be about 20mm.
- Once a year have your caravan manoeuvring system maintained and visually inspected. This inspection must include all the bolt/nut connections, the cables and electrical connections and lubrication of movable parts/joints.



**In case of any failure or problem, please contact your Camec Elite Pro® 2 EM305 supplier.**

## TROUBLESHOOTING

Should your manoeuvring system fail to operate, please check the following:

### Unit fails to operate, does not function at all:

- Make sure that the battery power isolation switch (29) is turned on.
- Check the cable-connection between the caravan battery and the control unit.
- Check the fuse (80A) in the red positive battery cable (Fig. 20). If the fuse is blown, it must be replaced with a fuse of the same value (80A). Never "bridge" the fuse (if needed contact your **Camec Elite Pro® 2 EM305** supplier). To replace the fuse, first disconnect the positive (+) power cable from the battery. Then release the mounting screws that hold the fuse (Fig. 20A), replace the fuse (Fig. 20B), and finally tighten the screws securely. Close the housing of the fuse and connect the positive (+) power cable again to the battery. The system is ready again for use.

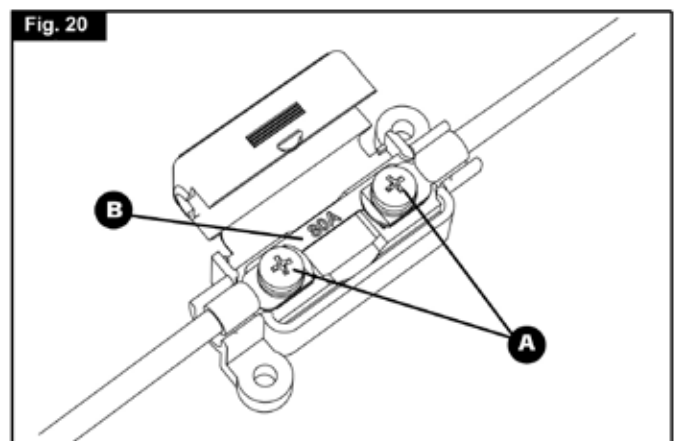

- Check the battery of the remote control handset. If empty, renew the 9V battery.
- Caravan battery could be empty. If empty, recharge completely or renew caravan battery before taking any further action.
- Caravan battery could be overloaded. Check your charging equipment and try to discharge the battery by connecting/using a light or any other load. If this does not give any result, renew caravan battery before taking any further action.
- Check the distance between the remote control and the caravan is not more than 5 metres. If there is no signal between the remote control handset and the control unit, the manoeuvring system will not function at all and the green LED on handset will blink.
- Check if there is any distortion signal (other transmitter, high power cables, Wifi etc.) that disturbs a good communication between remote control handset and control unit. If there is no good communication between the control unit and remote control handset, the manoeuvring system will not function and the green LED on remote control handset will blink.

In general, all error messages will reset automatically after one minute. If this is not the case, reset the electronics of the manoeuvring system by switching off the manoeuvring system via the isolation switch and the remote control handset for at least 15 seconds and then turn them on again.

#### **Unit fails to operate or moves intermittently:**

- Check the battery of the remote control. If empty, renew the 9V battery.
- Caravan battery could be empty. If empty, recharge completely or renew caravan battery before taking any further action.
- Caravan battery could be low - with the rollers engaged. Check the voltage drop on the caravan battery, if this drops well below 10 volts, charge or renew caravan battery
- Caravan battery could be overloaded. Check your charging equipment and try to discharge the battery by connecting/using a light or other load. If this does not give any result, renew caravan battery before taking any further action.
- Check the cable-connection between the caravan battery and the control unit.
- Badly connected or corroded battery terminals can cause intermittent problems, check battery terminals, clean and connect again.
- Check the distance between the remote control and the caravan is not more than 5 metres. If there is no signal between the remote control handset and the control unit, the manoeuvring system will not function at all and the green LED on handset will blink.
- Check if there is any distortion signal (other transmitter, high power cables, Wifi etc.) that disturbs a good communication between remote control handset and control unit. If there is no good communication between the control unit and remote control handset, the manoeuvring system will not function and the green LED on remote control handset will blink.

In general, all error messages will reset automatically after one minute. If this is not the case, reset the electronics of the manoeuvring system by switching off the manoeuvring system via the isolation switch and the remote control handset for at least 15 seconds and then turn them on again.

#### **Roller will not turn, spindle rotates freely:**

- The motor or gear is broken, please contact your **Camec Elite Pro® 2** EM305 supplier.

**In case of any doubt, please call your Camec Elite Pro® 2 supplier.**

## Contact Information

### Australia

47-63 Remington Drive

Dandenong South 3175

Phone: 1300 4 CAMEC (22632)

[www.camec.com](http://www.camec.com)

### New Zealand

Airport Business Centre

44 Montgomerie Road, Mangere

Phone: 0011 64 9 257 2419



**CAMEC**<sup>®</sup>

***GO FURTHER***