

# AirWerx 65X Dehumidifier

Crawl space & Basement & Commercial



Patented

## Key Features

- ▶ 1. Capacity:
  - 1) 120 Pints/Day.
  - 2) Size for: 1,300 Sq. Ft.
- ▶ 2. HVAC Remote System.
- ▶ 3. Outlet: 6" big diameter air outlet, focused dehumidifying.
- ▶ 4. Draining: Pump, Gravity Drain.
- ▶ 5. Super COP: 2.4 L/KWH.

## Overview

The AirWerx 65X is able to extract over 120 pints of moisture a day. This ensures you are protected from water damage and avoid any health complication caused by excess moisture. Its sheet metal housing guarantees durability by protecting the dehumidifier from damage while being moved.

Equipped with multilayer aluminum filters that help cleanse the air off any dust and impurities, auto defrosting system to avoid frost from forming and lowering the dehumidifier capacity. The AirWerx 65X state of the art design protects it from overheating.

Note: to maintain the effectiveness and efficiency of the AirWerx 65X dehumidifier, it is important to ensure the space the dehumidifier is installed is airtight. This guarantee that the dehumidifier is able to maintain the humidity level low (below 50%). The biggest source of moist indoors is outside humid air.

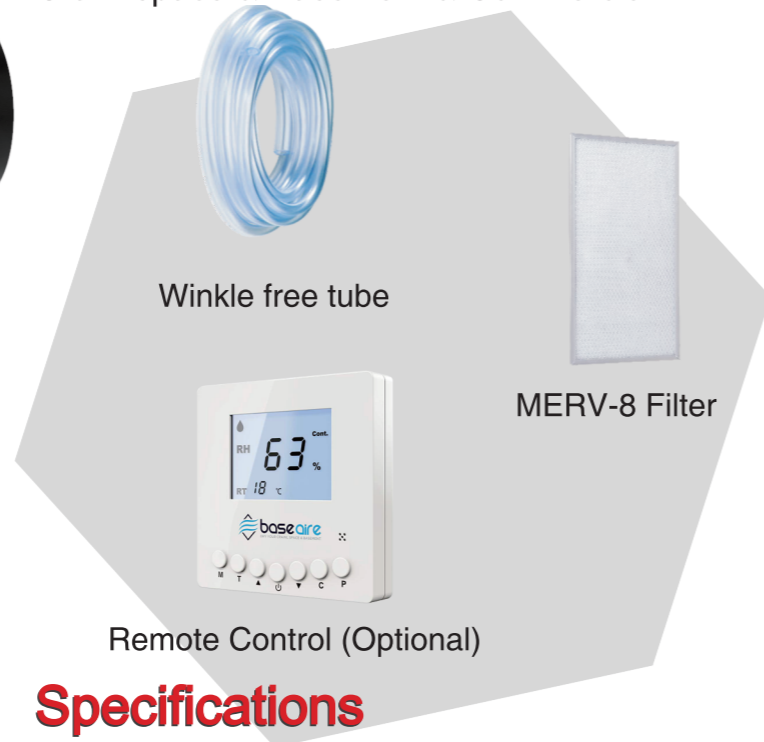

Winkle free tube

MERV-8 Filter

Remote Control (Optional)

## Specifications

Installation type/place	Small spaces – basements, crawl space, kitchen, laundry room.
Power	115V/60Hz
Size limit	Up to 1,300 Sq. Ft.
Air flow	130 CFM, 230 CMH
Installation type	Portable
Remote control	Yes
Display type	Digital.
Sound level	<52 DBA
Draining	Pump, Gravity Drain
Compressor type	Rotary
Defrosting control system	Auto Defrosting
Bypass air sensor	Yes.
Memory starting	All set settings remain the same even after a restart
Automatic humidistat control	Yes.
Easy handling	Plug and play design - easy to operate
Weight	57.3 lbs (26 Kgs)
Dimensions	Depth: 19.2 in. Height: 13.3 in. Width: 12.2 in.

# AirWerx 65X Dehumidifier

## Application

Compact - small - light - high capacity! These are but a few of the words that can be used to describe BaseAire AirWerx 65X. The AirWerx 65X is built for all areas dehumidification, thanks to its small size and high capacity makes it perfect to be deployed in any room in the house. Perfect for basement, crawl spaces or any other tight moist spaces in the house.

## All purpose use

- ▶ AirWerx 65X is equipped with a duct (150mm in diameter) for focused dehumidification.
- ▶ Remote controlled – the AirWerx 65X also you to control the dehumidifier setting remotely. Which saves time-saving and convenient.

## Capacity

This unit is able to extract at least 120 pints of moisture per day, which is very impressive comparing its size and low energy consumption.

## Support

All our customers enjoy effective support, thanks to your technical support team via phone, email or via live support. This ensures that all the issues encountered by our customers while using the AirWerx 65X are resolved promptly.

## Warranty

At BaseAire all over have a 5-year unit warranty. All our products are tested and proven to be fully operational before being released to the market. Our team of world engineers works tirelessly to ensure the AirWerx 65X unit will exceed your expectations.

## Performance

Equipped with a humidistat, the AirWerx 65X is able to sense a change in humidity and regulate the humidity levels accordingly.

Also equipped with durably coated coils with the stainless side plate.

Built to remain fully operational in low temperatures and air flow issues spaces like the crawl space or the basement.

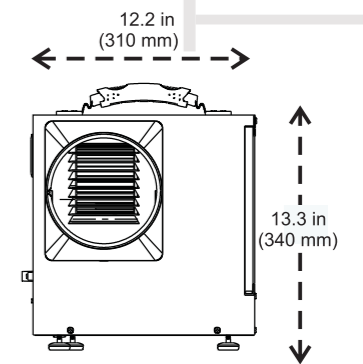

LEFT

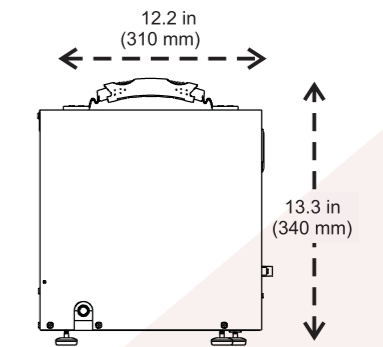

RIGHT

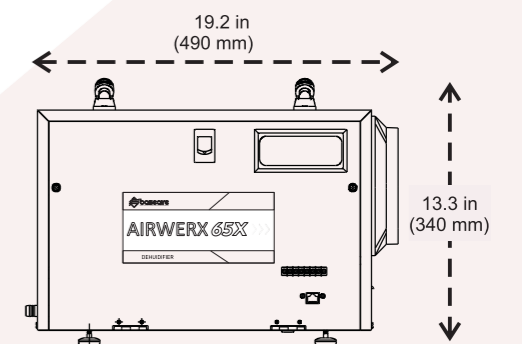

FRONT

Get rid of the mold and odor-buy the **AirWerx 65X** today

Specifications subject to change without notice.