

# AirWerx 35P

## Dehumidifier



Patented

Crawl space & Basement & Commercial

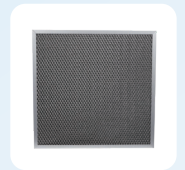

Winkle free tube

MERV-1 Filter



Remote Control (Optional)



Cable(Optional)

## Specifications

Feature	AirWerx 35P
cETL/Energy Star	✓
Compressor type	Rotary
More Thorough, and More Quick	✓
Rare Earth Alloy Tube Evaporator	✓
Auto Defrosting	✓
Easy Handling	✓
Environmental R32 Refrigerant	✓
Optional Remote control	✓
HVAC Remote System	✓
Automatic humidistat control	✓
Memory Starting	✓
Low Temperature	✓
Bypass air sensor	✓

**Note:** To maintain the effectiveness and efficiency of the AirWerx 35P dehumidifier, it is important to ensure the space the dehumidifier is installed is alright. This guarantee that the dehumidifier is able to maintain the humidity level low (below 50%). The biggest source of moist indoors is outside humid air.

## Key Features

- GLGR Technology
- Supper COP:2.0L/KWH
- HVAC Remote System
- Smallest Size
- Quick Access for Service
- Draining: Pump, Gravity Drain
- Rare Earth Alloy Tube Evaporator

Specifications	AirWerx 35P
Installation type/place	Small spaces-basements, crawl space, kitchen, laundry room
Power	115V/60Hz
Current	2.9A
Size limit	Up to 1,000 Sq.Ft.
Filter	MERV-1 Filter
Air flow	115 CFM
Installation type	Portable
Display type	Digital
Sound level	<50 dBA
Refrigerant	R32
Feet	Adjustable Feet
Draining	Pump, Gravity Drain
Defrosting control system	Auto Defrosting
Easy handling	Plug and Play Design -Easy to Operate
Functioning Temperature Range	33-105°F
Weight	39.7 lbs
Dimensions (L x W x H)	15.35×11.2×11.4 inches

## Overview

The AirWerx 35P is also able to extract over 70pints of moisture a day. This ensures you are protected from water damage and avoid any health complication caused by excess moisture. Its sheet metal housing guarantees durability by protecting the dehumidifier from damage while being moved.

Equipped with MERV-1 filters that help cleanse the air off any dust and impurities, auto defrosting system to avoid frost from forming and lowering the dehumidifier capacity. The AirWerx 35P state of the art design protects it from overheating.

## Application

Compact-small-light-high capacity! These are but a few of the words that can be used to describe BaseAire AirWerx 35P. The AirWerx 35P is built for all areas dehumidification, thanks to its small size and high capacity makes it perfect to be deployed in any room in the house. Perfect for basement, crawlspace or any other tight moist spaces in the house.

## All Purpose Use

Remote controlled-The AirWerx 35P also you to control the dehumidifier setting remotely. Which saves time-saving and convenient.

## Capacity

This unit is able to remove 35 pints per day at AHAM condition, 70 pints at saturation, up to 1,000 sq.ft, lowering the humidity to comfortable levels in a short period.

## Support

All our customers enjoy effective support, thanks to your technical support team via phone, email or via live support. This ensures that all the issues encountered by our customers while using the AirWerx 35P are resolved promptly.

## Warranty/Support

At BasAire all over have a **5**-year unit warranty.

ALL our products are tested and proven to be fully operational before being released to the market. Our team of world engineers works tirelessly to ensure the AirWerx 35P unit will exceed your expectations.

## Performance

Equipped with a humidistat, the AirWerx 35P is able to sense a change in humidity and regulate the humidity levels accordingly

Also equipped with durably coated coils with the stainless side plate.

Built to remain fully operational in low temperatures and air flow issues spaces like the crawl space or the basement.

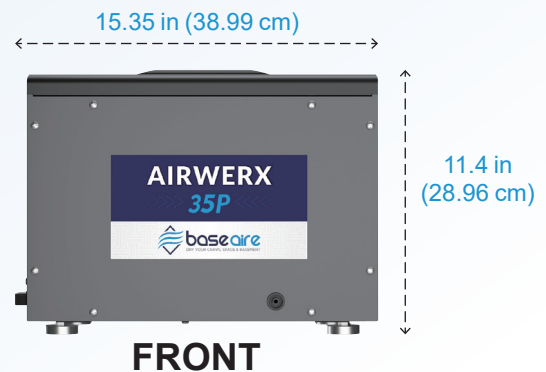
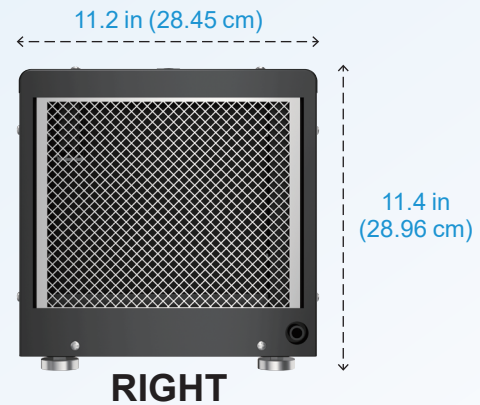
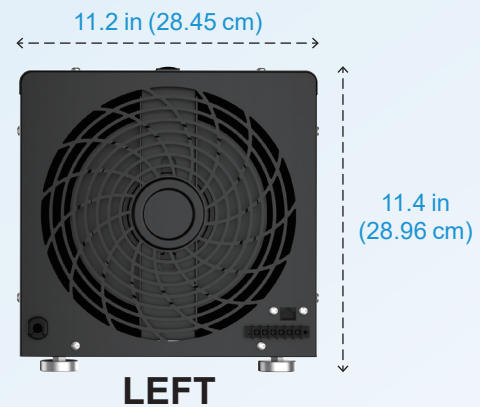

Specifications subject to change without notice.