

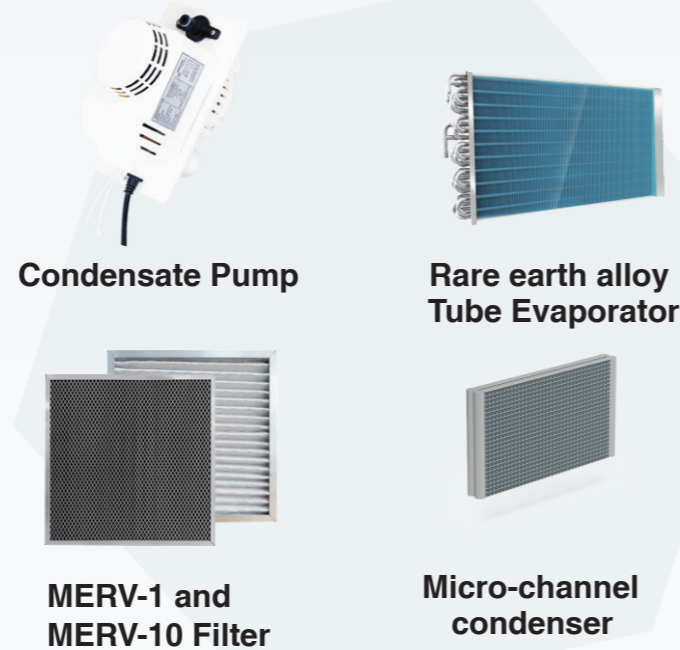

AirWerx 120X

Dehumidifier

Whole House Dehumidifier for Crawl space & Basement



Patent pending

Key Features

- 1. Capacity:
 - 1) 120 Pints/Day, AHAM (80°F, 60%);
 - 2) 235 Pints/Day, Saturation (90°F, 90%).
 - 3) 93 Pints/Day @ (73°F, 60%).
 - 4) Size for: 3,300 Sq. Ft.
- 2. Outlet: 10" big diameter air outlet, focused dehumidifying.
- 3. Draining: Condensate pump.
- 4. Supper COP : 2.7 L/KWH.

Overview

We at BaseAire are have dedicated our lives to helping you combat high humidity levels, the AirWerx 120X unit is one of the best dehumidifiers in the market today. With a power capacity of extracting over 120 pints per day (PPD), you are guaranteed a long-term fix to all your humidity issues.

The AirWerx 120X is the perfect dehumidifier for your crawl space, basement or the whole house, where most humidity issues are experienced. Equipped with a powerful condensate pump and a pipe, all the extracted water is pumped out of the house and poured out away from the house.

Specifications

Installation type/place	Medium size rooms.
Power	115V/60Hz
Approved for commercial use	Yes
Size limit	Up to 3,300 Sq. Ft
Air flow	290 CFM
Installation type	Portable
Remote control	Yes
Display type	Digital.
Sound level	<60 dBA
Draining	Condensate pump
Compressor type	Rotary
Bypass air sensor	Yes.
Memory starting	All set settings remain the same even after a restart
Automatic humidistat control	Yes.
Easy handing	Plug and play design - easy to operate
Weight	88 lbs(40kg)
Dimensions	Depth: 23.8 in. Height: 17.9 in. Width: 14.7 in.



AirWerx 120X

Dehumidifier

Features

- Fully operational at Low temperatures.
- Easy access to the main board for easy maintenance.
- Design to stimulate airflow in spaces with airflow issues.
- Pipe drainage for the extracted water pumps out by the condensate pump.
- Filter for air purification.
- Full water protection.
- Rare earth alloy Tube Evaporator.

Functionalities

The AirWerx 120X is equipped with a duct for precise dehumidification. Has an automatic fault judge, easy access to the mainboard for easy maintenance. Remote control for convenience and to save time.

Capacity

The AirWerx 120X has a capacity of 120 pints per day (PPD) of moisture.

Performance

The AirWerx 120X is specially designed to remain fully operational at low temperature. The unit advanced design to allow it to use the air already processed to stimulate air circulation when installing in a space (like the crawl space, basement, or whole house) with airflow issues.

Customer Support

At BaseAire we have a dedicated technical support team that is available for our customers. We ensure that all our customers are able to receive the help they need promptly. For any queries with the AirWerx 120X unit send us an email or call us now!

Warranty

We at BaseAire ensure that all our units are thoroughly checked and tested, to ensure they are 100% operational to meet and exceed our customer's needs and expectations.

Application

Increased moisture in the house can cause increased growth of mold, mildew and dust mites; Which has been proven to cause serious respiratory problems and skin allergies. Increased moisture level provides fungi the best environment to grow cause wood and item to the house to decay.

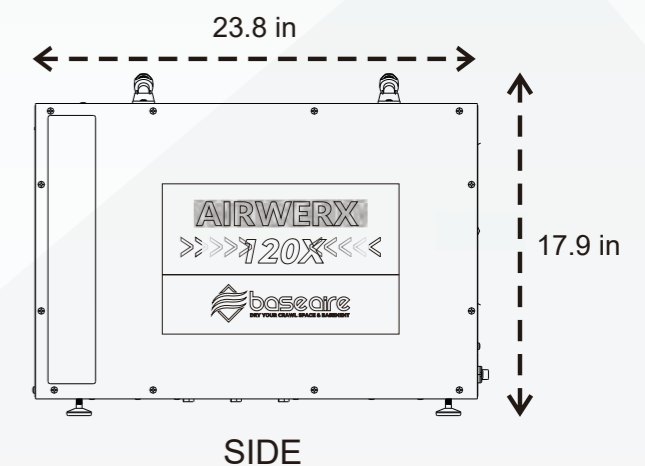
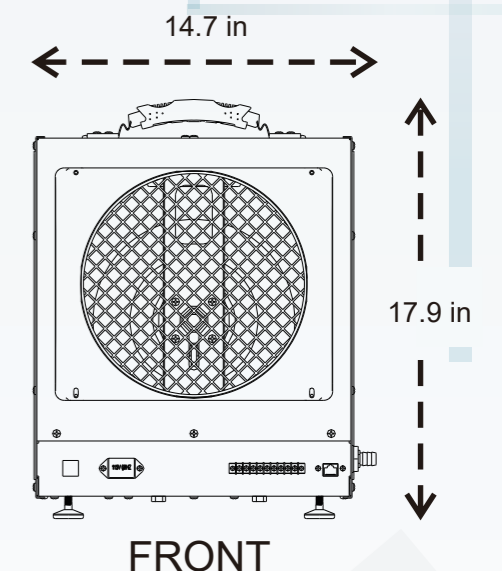

The AirWerx 120X has a 5 years warranty.

Specifications subject to change without notice.

EFFICIENT • LARGE CAPACITY • POWERFUL
INDUSTRY • RESIDENTIAL HOMES
STORES • RESTORATION

Web: www.baseaire.com
E-mail: sales@baseaire.com
Tel: 1-888-641-8862