

## Assembly Information

Product Code: 144-962 (MO-0009-A)  
 Description: 5hp 3500 RPM Custom Water Cooled Induction Motor Wire Assembly Diagram

Revision: 1  
 Date Drawn: 9/21/2018  
 Drawn By: RWC  
 Date Last Saved: 9/25/2018

739-215  
 mount in re-purposed  
 capacitor can, mounted  
 to top of motor

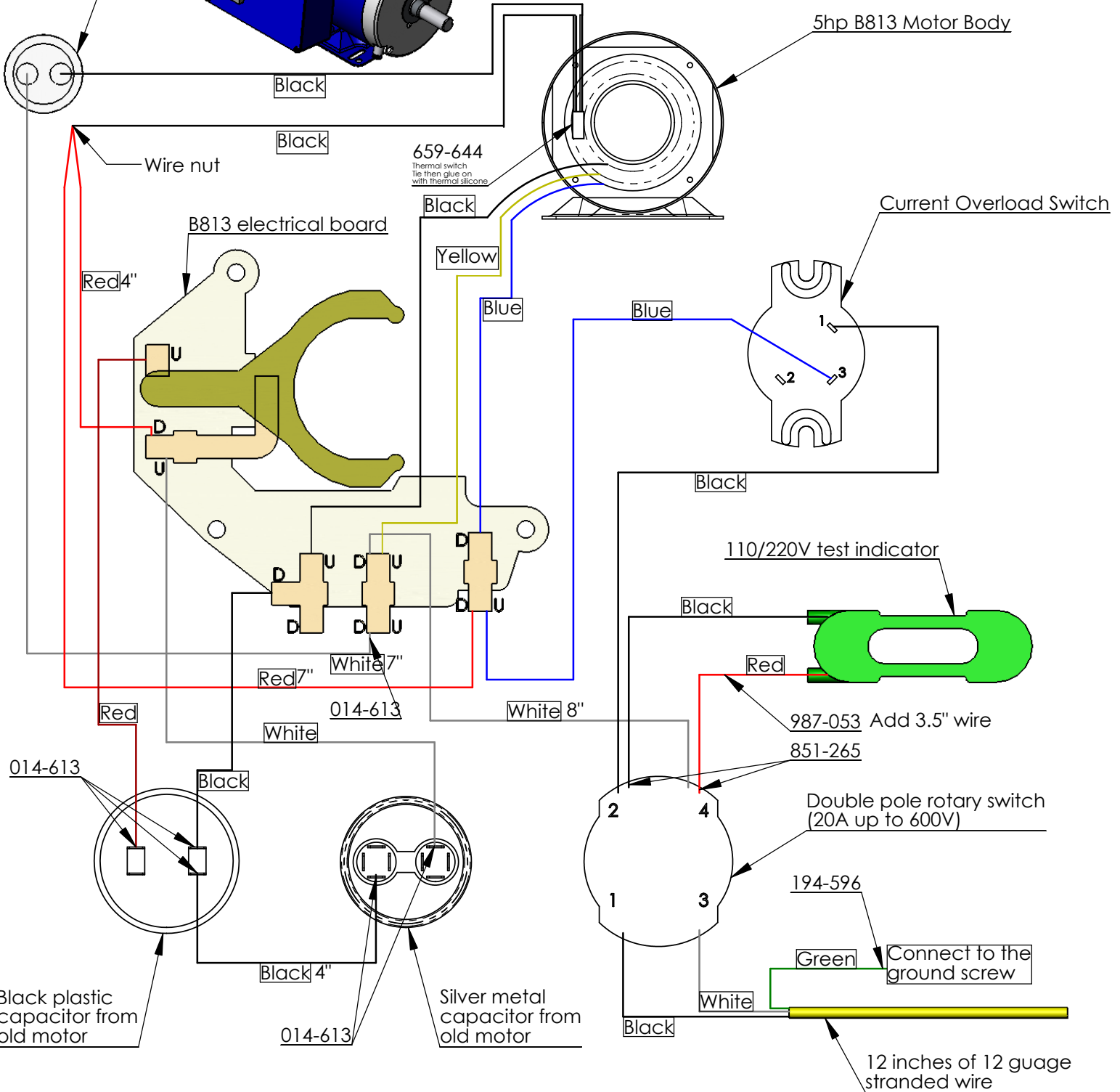
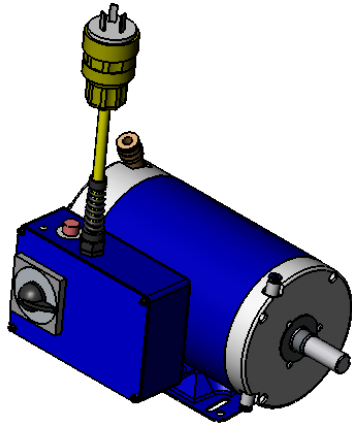

Reference	Quantity	Description
014-613	6	16-14 AWG 0.250 tab female bare flag electrical terminal
194-596	1	12-10 wire #10 ring electrical terminal
851-265	2	16-14 AWG #4-6 fork electrical terminal (Blue)
987-053	1	16-14 AWG butt splice electrical connector (Blue)
	1	Red wire nut

**D** means the connector is on the back of the board.  
**U** means the connector is on the front of the board.