



**PTW-Series**  
Pneumatic Torque Wrenches

**ETW-Series**  
Electric Torque Wrenches

Smart, Simple and  
Productive Solutions  
for Controlled Bolting



▼ Shown: PTW1000



## Continuous Rotation Controlled Torque



### Typical Pneumatic Torque Wrench Applications

#### Mining

- Track maintenance
- Undercarriage maintenance
- Wheel maintenance
- Shovel maintenance

#### Power Generation

- Turbine bolts
- Tower segments
- Turbine casings

#### Oil and Gas

- Pipe flanges
- Valves
- Manway covers
- Pressure vessels

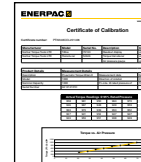

### Calibration Certificate

All PTW tools are CE declared and are shipped complete with a calibration certificate.



### Productivity

- High speed continuous rotation for constant torque output
- Low friction planetary gearbox design minimizes wear and extends uptime

### Safety

- Ergonomic, low vibration design reduces fatigue and the risk of vibration related injuries for the operator
- Low noise air motor provides quiet, consistent performance for indoor and outdoor applications

### Convenience

- Provided with standard reaction arm; wide assortment of custom arms and accessories are available
- Available with or without Filter-Regulator-Lubricator (FRL)
- Unique calibration certificate provided with each tool

▼ PTW-Series Pneumatic Torque Wrenches are ideal for applications where speed and precision are critical, such as track maintenance.



◀ The PTW1000 makes quick work of this flange maintenance job.



# Pneumatic Torque Wrenches



## PTW-Series Pneumatic Torque Wrenches

Enerpac PTW-Series Pneumatic Torque

Wrenches are designed for applications that require speed and control. The standard package includes a Torque Wrench with a calibration certificate, an FRL (Filter/Regulator/Lubricator), and a 10 ft. (3 m) long, 1/2" (13 mm) diameter air hose, which connects the FRL to the wrench.

Once the air hoses are connected, the operator simply adjusts the air pressure on the FRL to achieve the desired torque using the calibration certificate. After this, the tool is ready to go to work!\*

The air source used with the PTW system must be regulated and/or limited to 120 psi (8.3 bar), and must be capable of providing a volume of at least 50 CFM (85 CMH) at 100 psi (6.9 bar). A separate 1/2" (13 mm) hose (not included) must be used to connect the FRL to the air supply.

\*See instruction manual for comprehensive instructions

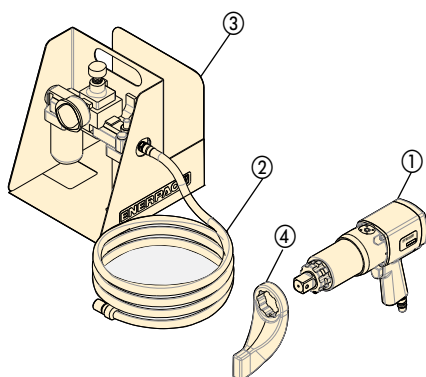

- ① PTW Torque Wrench
- ② Hose
- ③ Filter-Regulator-Lubricator
- ④ Reaction Arm

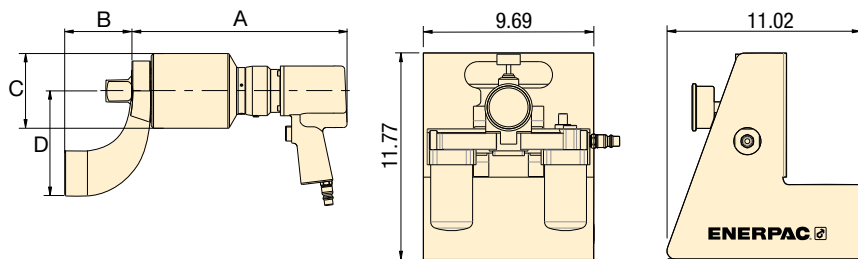

All tools are shipped complete with standard reaction arm and FRL\*.

### ▼ SELECTION CHART

Minimum Torque		Maximum Torque		Square Drive (in)	Model Number*	RPM	Dimensions (in)				Weight** (lbs)
(Ft.lbs)	(Nm)	(Ft.lbs)	(Nm)				A	B	C	D	
300	407	1000	1356	1	PTW1000C	12.6	10.70	3.27	2.83	5.12	18
500	678	2000	2712	1	PTW2000C	8.0	11.26	3.27	3.11	5.24	19.5
900	1220	3000	4067	1	PTW3000C	3.1	13.50	3.27	3.74	5.24	23
1300	1763	6000	8135	1 1/2	PTW6000C	2.5	14.40	4.49	5.00	7.00	39

\* To order without FRL and hose, remove "C" Suffix (e.g. PTW3000).

\*\* Weight of wrench only without reaction arm. Reaction arm weight for PTW1000, PTW2000, PTW3000 is 2.9 lbs. and for the PTW6000 is 7.75 lbs.

## PTW Series



Maximum Output Torque:

**6000 Ft.lbs**

Square Drive Range:

**1 - 1 1/2 inch**



### Pneumatic Torque Wrench Accessories

Enerpac offers a full line of accessories including a range of reaction arms and drives.

Page: 7



### Filter-Regulator-Lubricator

Recommended for use with all PTW pneumatic torque wrenches.

Provides clean, lubricated air and allows for air pressure adjustment.

Order model number\*

**FRL120C**



### BSH-Series Sockets

Heavy-Duty Impact Sockets for power driven torquing equipment.

6



### Hydraulic Torque Wrenches

Enerpac offers a complete range of square drive and hexagon cassette torque wrenches. Details on [www.enerpac.com](http://www.enerpac.com).

▼ Shown: ETW1000



## Your Simple Solution for Smart Bolting



### Touchscreen Control Box

ETW tools feature an easy to use, interactive touch-screen control box, which helps make even the most complex jobs simple to complete.



### Easy Access to Controls

Controls on back of wrench with LED display allow user to directly input desired torque, change direction of rotation, and monitor the fastening process.

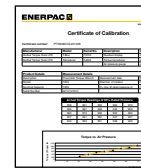

### Certifications, Declarations

All ETW tools:

- Are shipped complete with a calibration certificate
- Are certified for North American Electrical Safety by CSA International
- Carry a CSA US and Canada mark
- Are CE declared



▼ *ETW-Series Electric Torque Wrenches are ideal for high volume fastening applications that require precision and traceability, such as this wind tower job.*



### Performance

- High speed continuous rotation gets the job done faster
- Torque and angle functionality allows input of nominal torque value followed by a specific angle of rotation
- Pass/Fail LED indicator on back of tool verifies fastening has been completed according to specified input

### Simplicity

- Control box with large seven-inch touchscreen simplifies tool operation
- Controls on back of wrench enable operator to monitor and manage the fastening process without returning to the control box
- Brightly lit three line LED display on wrench is easy to read in any environment, even in bright sunlight

### Traceability

- Fastening record can be viewed on-screen and transferred through standard USB connection on the control box
- Each tool is performance tested and shipped complete with a factory calibration certificate

### Safety

- Lift points on wrench enable use with positioning handle or lifting device for greater handling safety
- Ground fault detector protects operator in the event of insufficient grounding





## ETW-Series Electric Torque Wrenches

### Enerpac ETW-Series Electric Torque Wrenches

are particularly well suited to complex jobs which demand precision and traceability. The tools feature an automatic mode, which helps simplify and automate complex jobs, including those with torque and angle specifications, through the creation of presets.

Using the touchscreen, simply input the number of fasteners and desired torque value for each fastening step, followed by the required angle of turn. This sequence may then be saved as an automatic preset for future use.

For simpler jobs, torque values may be input with a digital slider on the touchscreen, or directly into the rear control panel of the wrench.

Once the input torque is achieved, the tool stalls, and a pass/fail indicator verifies that it is ready to move on to the next fastener.

When the job is completed, the fastening record can be viewed on the touch screen, or exported to a computer via a USB connection on the control box.

## ETW Series



Maximum Output Torque:

**6000 Ft.lbs**

Square Drive Range:

**1 - 1½ inch**



### Torque Wrench Accessories

Enerpac offers a full line of accessories including a wide range of reaction arms and drives.

Page: **7**



### BSH-Series Sockets

Heavy-Duty Impact Sockets for power driven torquing equipment.

**6**

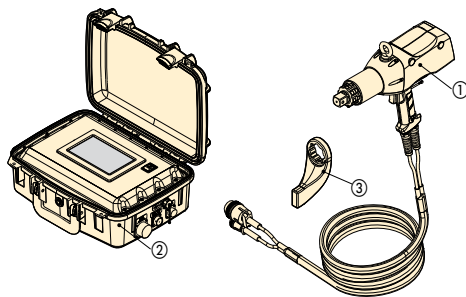

- ① ETW Torque Wrench
- ② Control Box
- ③ Reaction Arm

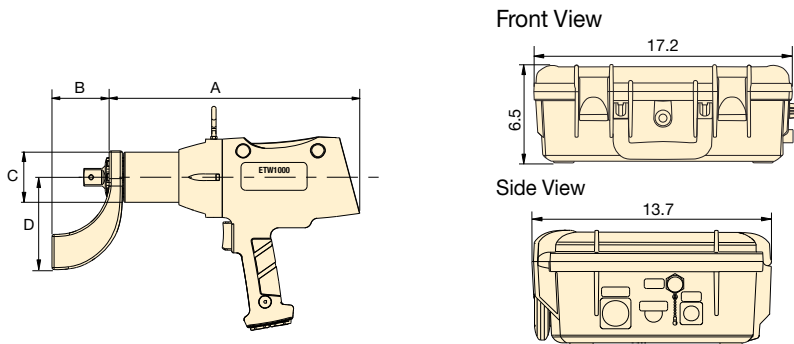

### Voltage: (Model No. ending with suffix)

**B** = 115V, 60 Hz

**I** = 230V, 60 Hz (with NEMA 6-15 plug)

**E** = 230V, 50 Hz (with commonly used European (SCHUKO) plug)

Minimum Torque		Maximum Torque		Square Drive (in)	Model Number	Voltage	RPMs	Dimensions (in)				Wrench Weight* (lbs)
(Ft.lbs)	(Nm)	(Ft.lbs)	(Nm)					A	B	C	D	
200	270	1000	1355	1.0	ETW1000B	115V 60 Hz	9.8	14.4	3.3	2.8	5.2	18.1
200	270	1000	1355	1.0	ETW1000I	230V 60 Hz	15.2	14.4	3.3	2.8	5.2	18.1
200	270	1000	1355	1.0	ETW1000E	230V 50 Hz	15.2	14.4	3.3	2.8	5.2	18.1
400	540	2000	2710	1.0	ETW2000B	115V 60 Hz	5.8	15.0	3.3	3.1	5.2	19.7
400	540	2000	2710	1.0	ETW2000I	230V 60 Hz	9.0	15.0	3.3	3.1	5.2	19.7
400	540	2000	2710	1.0	ETW2000E	230V 50 Hz	9.0	15.0	3.3	3.1	5.2	19.7
600	810	3000	4065	1.0	ETW3000B	115V 60 Hz	2.8	17.1	3.3	3.7	5.2	26.3
600	810	3000	4065	1.0	ETW3000I	230V 60 Hz	4.3	17.1	3.3	3.7	5.2	26.3
600	810	3000	4065	1.0	ETW3000E	230V 50 Hz	4.3	17.1	3.3	3.7	5.2	26.3
1200	1625	6000	8135	1.5	ETW6000B	115V 60 Hz	1.9	17.8	4.5	5.0	7.0	42.1
1200	1625	6000	8135	1.5	ETW6000I	230V 60 Hz	2.9	17.8	4.5	5.0	7.0	42.1
1200	1625	6000	8135	1.5	ETW6000E	230V 50 Hz	2.9	17.8	4.5	5.0	7.0	42.1

\* Weight of wrench only without reaction arm. Reaction arm weight for ETW1000, ETW2000, ETW3000 is 2.9 lbs. and for the ETW6000 is 7.75 lbs. Weight of control box is 20 lbs.

# BSH-Series, Heavy-Duty Sockets

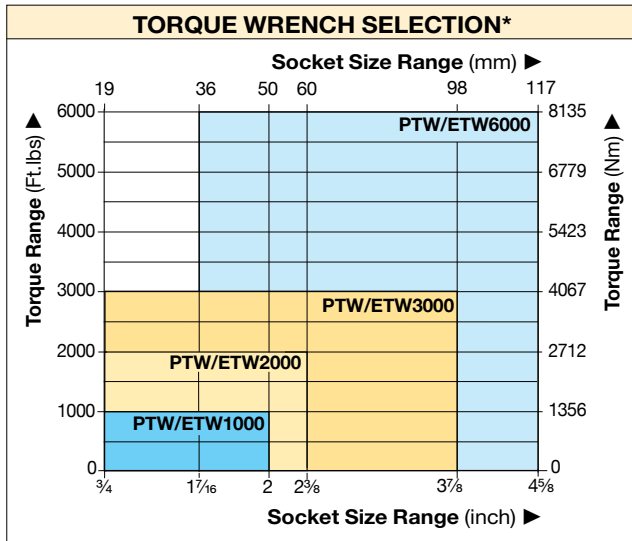

## BSH Series



Hexagon Sizes:

**3/4 - 4 5/8 in | 19 - 115 mm**



### Pin and Ring

All sockets are supplied with a "Pin and Ring" to hold the socket in place on the square drive of the tool.



### Select the Right Torque

Choose your Enerpac Torque Wrench using the untightening rule of thumb: Loosening torque equals about 250% of tightening torque.

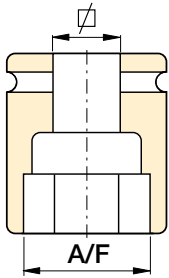

IMPERIAL SOCKETS*							
1" Square Drive				1 1/2" Square Drive			
Model Number	A/F (in)	Model Number	A/F (in)	Model Number	A/F (in)	Model Number	A/F (in)
BSH1019	3/4"	BSH10231	2 5/16"	BSH15144	1 7/16"	BSH15281	2 13/16"
BSH10088	7/8"	BSH10238	2 3/8"	BSH1538	1 1/2"	BSH15288	2 7/8"
BSH10094	15/16"	BSH10244	2 7/16"	BSH15156	1 9/16"	BSH1575	2 15/16"
BSH1027	1 1/16"	BSH10250	2 1/2"	BSH15163	1 5/8"	BSH15300	3"
BSH1030	1 3/16"	BSH1065	2 9/16"	BSH1543	1 11/16"	BSH15306	3 1/16"
BSH10125	1 1/4"	BSH10263	2 5/8"	BSH15175	1 3/4"	BSH15313	3 1/8"
BSH10131	1 5/16"	BSH10269	2 11/16"	BSH1546	1 13/16"	BSH15319	3 3/16"
BSH1035	1 3/8"	BSH1070	2 3/4"	BSH15188	1 7/8"	BSH15325	3 1/4"
BSH10144	1 7/16"	BSH10281	2 13/16"	BSH15194	1 15/16"	BSH15338	3 3/8"
BSH1038	1 1/2"	BSH10288	2 7/8"	BSH15200	2"	BSH15350	3 1/2"
BSH10156	1 9/16"	BSH1075	2 15/16"	BSH15206	2 1/16"	BSH15363	3 5/8"
BSH10163	1 5/8"	BSH10300	3"	BSH15213	2 1/8"	BSH1595	3 3/4"
BSH1043	1 11/16"	BSH10306	3 1/16"	BSH15219	2 3/16"	BSH15388	3 7/8"
BSH10175	1 3/4"	BSH10313	3 1/8"	BSH15225	2 1/4"	BSH15100	3 15/16"
BSH1046	1 13/16"	BSH10319	3 3/16"	BSH15231	2 5/16"	BSH15400	4"
BSH10188	1 7/8"	BSH10325	3 1/4"	BSH15238	2 3/8"	BSH15105	4 1/8"
BSH10194	1 15/16"	BSH10338	3 3/8"	BSH15244	2 7/16"	BSH15419	4 3/16"
BSH10200	2"	BSH10350	3 1/2"	BSH15250	2 1/2"	BSH15425	4 1/4"
BSH10206	2 1/16"	BSH10363	3 5/8"	BSH1565	2 9/16"	BSH15110	4 5/16"
BSH10213	2 1/8"	BSH1095	3 3/4"	BSH15263	2 5/8"	BSH15438	4 3/8"
BSH10219	2 3/16"	BSH10388	3 7/8"	BSH15269	2 11/16"	BSH15450	4 1/2"
BSH10225	2 1/4"			BSH1570	2 3/4"	BSH15463	4 5/8"

METRIC SOCKETS*			
1" Square Drive		1 1/2" Square Drive	
Model Number	A/F (mm)	Model Number	A/F (mm)
BSH1019	19	BSH1536	36
BSH1024	24	BSH15163	41
BSH1027	27	BSH1546	46
BSH1030	30	BSH1550	50
BSH1032	32	BSH1555	55
BSH1036	36	BSH1560	60
BSH10163	41	BSH1565	65
BSH1046	46	BSH1570	70
BSH1050	50	BSH1575	75
BSH1055	55	BSH1580	80
BSH1060	60	BSH1585	85
BSH1065	65	BSH1590	90
BSH1070	70	BSH1595	95
BSH1075	75	BSH15100	100
BSH1080	80	BSH15105	105
BSH1085	85	BSH15110	110
BSH1090	90	BSH15115	115
BSH1095	95		
BSH10100	100		

\* Socket size recommendations are based on torque output of tool and socket size range. Additional socket sizes available on request.

# PTW, ETW-Series, Torque Wrench Accessories

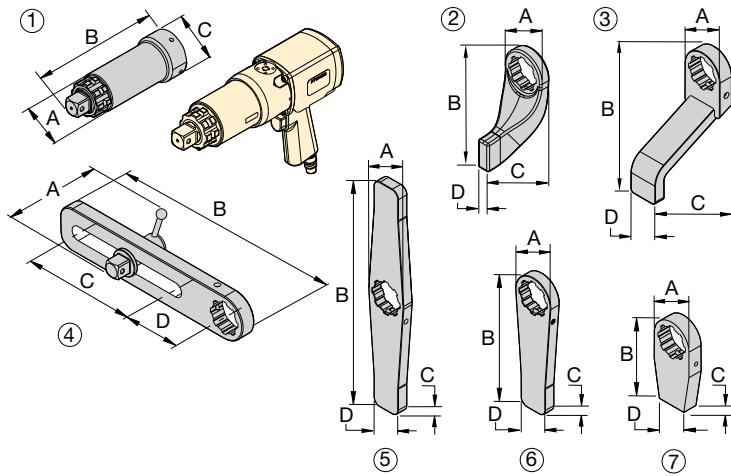

**PTW,  
ETW  
Series**



Maximum Output Torque:

**6000 Ft.lbs**

Square Drive Range:

**1 - 1½ inches**

▼ Optional accessories for use with PTW1000, ETW1000, PTW2000, ETW2000, PTW3000, ETW3000 models							
No.	Description	Model No.	Application	Dimensions in inches			
				A	B	C	D
1	Extended Drive, 6 inch (152 mm)	ED6TWS	Nose extension, primarily for truck wheel bolts	2.44	8.11	2.87	—
1	Extended Drive, 12 inch (305 mm)	ED12TWS		2.44	15.12	2.87	—
1	Extended Drive, 18 inch (457 mm)	ED18TWS		2.44	20.12	2.87	—
2	Standard Reaction Arm	RATWS	Standard arm included with PTW/ETW model	2.99	6.77	4.02	0.83
3	Extended Reaction Arm	ERATWS	Long plate for use with deep well sockets	2.87	5.91	7.95	2.01
4	Sliding Reaction Arm	SLRATWS	For widely spaced and uneven bolt centers	4.41	15.00	7.99	4.02
5	Double Straight Reaction Arm	DSATWS	Reduces time to reposition arm *	2.87	15.98	0.75	4.02
6	Straight Reaction Arm	SRATWS	Long plate for wide spaced reaction points	2.87	9.45	0.75	2.01
7	Blank Reaction Arm **	BLTWS	Weldable blank for custom applications **	2.83	5.94	0.98	2.01
▼ For use with PTW6000, ETW6000 models							
1	Extended Drive 6 inch (152 mm)	ED6TWL	Nose extension, primarily for truck wheel bolts	3.31	9.13	4.02	—
1	Extended Drive 12 inch (305 mm)	ED12TWL		3.31	15.12	4.02	—
2	Standard Reaction Arm	RATWL	Standard arm included with PTW/ETW model	4.02	9.02	5.75	1.26
3	Extended Reaction Arm	ERATWL	Long plate for use with deep well sockets	4.02	10.00	7.24	2.52
4	Sliding Reaction Arm	SLRATWL	For widely spaced and uneven bolt centers	5.98	16.50	7.48	4.49
5	Double Straight Arm	DSATWL	Reduces time to reposition arm *	4.02	20.00	1.26	2.24
6	Straight Reaction Arm	SRATWL	Long plate for wide spaced reaction points	4.02	12.01	1.26	2.24
7	Blank Reaction Arm **	BLTWL	Weldable blank for custom applications **	4.02	5.98	1.26	2.24

\* Time to reposition arm when repeatedly moving from tightening to loosening.

\*\* ⚠ WARNING: Blank reaction arms must be heat treated to HRc 38-42 prior to use.

## Typical PTW, ETW-Series Torque Wrench Applications



### Mining

- Track maintenance
- Undercarriage maintenance
- Wheel maintenance
- Shovel maintenance



### Power Generation

- Turbine bolts
- Tower segments
- Turbine casings



### Oil & Gas

- Pipe flanges
- Valves
- Manway covers
- Pressure vessels

# PTW, ETW-Series Torque Wrenches

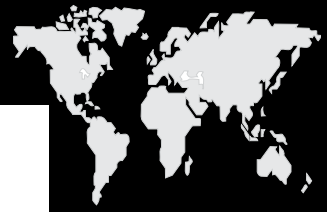

## The Industrial Tools Line

### Cylinders and Lifting Products

- General Purpose
- Aluminum: Lock Nut, Solid, and Hollow Plunger
- Pancake, Low Height
- Pull
- Hollow Plunger
- Precision
- Long Stroke
- High Tonnage
- Jacks
- Level Lift System
- Pow'R-RISER® Lifting Jacks
- Pow'R-LOCK™ Lifting Jacks
- Extreme Environment Products

### Pumps

- Manual
- Cordless and Electric Driven
- Compressed Air Driven
- Petrol Driven

### System Components

- Hoses, Couplers, Oil
- Manifolds, Fittings
- Gauges, Adaptors

### Valves

- 3-and 4-Way Directional
- Pressure and Flow Control

### Presses

- H-Frame, Roll Frame
- C-Clamp and Arbor
- Tension Meters, Load Cells

### Pullers

- Master Pullers Sets
- Multi Purpose Puller Sets
- Posi Lock® Pullers

### Tools

- Maintenance Sets
- Punches
- Lifting Wedges
- Machine Lifts
- Load Skates
- Wedgie, Spreaders
- Cutters
- Pipe Benders

### Bolting Tools

- Multipliers
- Torque Wrenches
- Impact Sockets
- Wrench and Tensioner Pumps
- Twin Safety Hoses
- Nut Cutters / Splitters
- Flange/Wedge Spreaders
- Flange Alignment Tools
- Flange Face Tool

### Integrated Solutions

- Synchronized Lifting Systems
- Jack-Up Systems
- Bridge Launching Systems
- Synchronized Hoisting Systems
- Hydraulic Gantries
- Heavy Lifting Strand Jacks
- Skidding Systems
- Self-Erecting Towers
- Self Propelled Modular Transporter
- Chain Pulling Systems

## Enerpac Worldwide Locations

For a complete list of addresses see:  
[www.enerpac.com/en-us/enerpac-locations](http://www.enerpac.com/en-us/enerpac-locations)

## About Enerpac

Enerpac is the leading global provider of high-pressure hydraulic tools and solutions with a broad range of products, local expertise and worldwide distribution network. With a proven track record in a wide range of markets, Enerpac designs and manufactures high-quality tools and solutions for all industrial applications.

Enerpac has gained unique experience in delivering hydraulic solutions for the controlled movement and positioning of heavy objects. Enerpac supports your business by offering the right solutions and service to help you get your work done efficiently and safely.



### [www.enerpac.com](http://www.enerpac.com) for latest Enerpac information

- New products
- Trade shows
- Manuals (instruction and repair sheets)
- Nearest Distributors and Service Centers
- Enerpac products in action



### Enerpac catalogs/brochures to meet your needs:

To obtain your copy just give us a call, or visit our Internet site [www.enerpac.com](http://www.enerpac.com)



### Enerpac Bolting Vans

- Demonstrate Enerpac Bolting Tools on your premises
- Calibrate all Bolting Tool brands
- Training for the safe and efficient use of Bolting Tools



### Enerpac Academy

Enerpac Academy is our in-house training center, set up exclusively for Enerpac business partners, Enerpac users and Enerpac employees: training programs ranging from tool expertise, repairs and maintenance, to safe operation of high-pressure hydraulic tools.

Your Enerpac Distributor:

e-mail: [info@enerpac.com](mailto:info@enerpac.com)  
Internet: [www.enerpac.com](http://www.enerpac.com)

