

▼ Shown: PTW1000



Continuous Rotation Controlled Torque



Typical Pneumatic Torque Wrench Applications

Mining

- Track maintenance
- Undercarriage maintenance
- Wheel maintenance
- Shovel maintenance

Power Generation

- Turbine bolts
- Tower segments
- Turbine casings

Oil and Gas

- Pipe flanges
- Valves
- Manway covers
- Pressure vessels

Productivity

- High speed continuous rotation for constant torque output
- Low friction planetary gearbox design minimizes wear and extends uptime

Safety

- Ergonomic, low vibration design reduces fatigue and the risk of vibration related injuries for the operator
- Low noise air motor provides quiet, consistent performance for indoor and outdoor applications

Convenience

- Provided with standard reaction arm; wide assortment of custom arms and accessories are available
- Available with or without Filter-Regulator-Lubricator (FRL)
- Unique calibration certificate provided with each tool

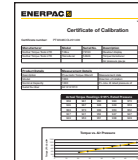

Calibration Certificate

All PTW tools are CE declared and are shipped complete with a calibration certificate.



◀ The PTW1000 makes quick work of this flange maintenance job.

▼ PTW-Series Pneumatic Torque Wrenches are ideal for applications where speed and precision are critical, such as track maintenance.



Pneumatic Torque Wrenches

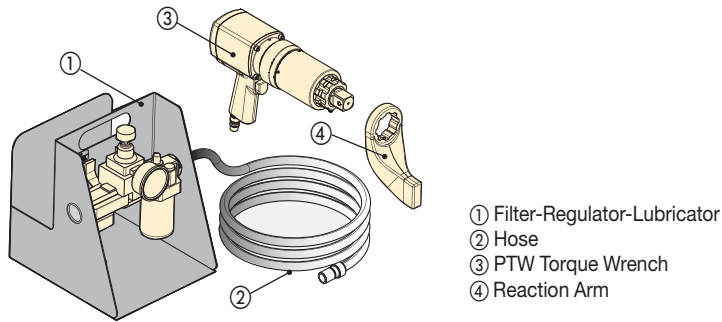

- ① Filter-Regulator-Lubricator
- ② Hose
- ③ PTW Torque Wrench
- ④ Reaction Arm

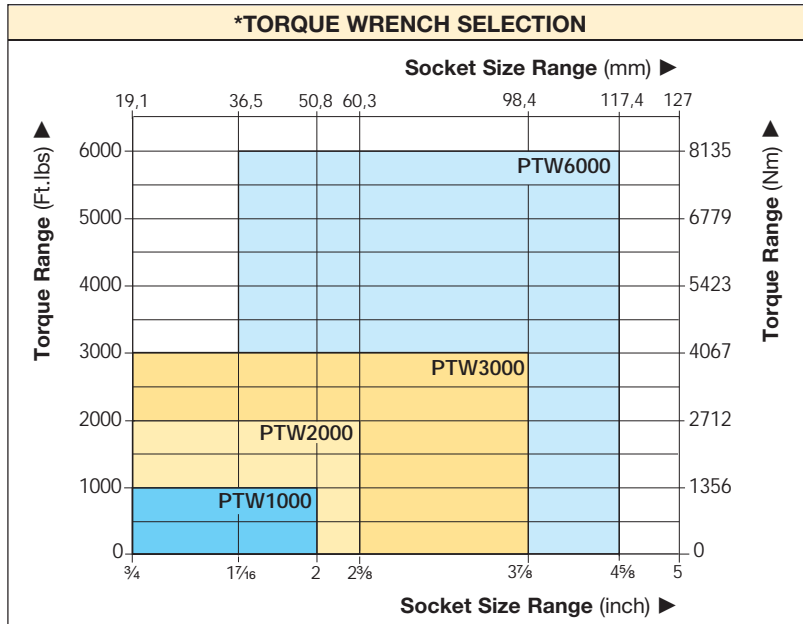

*Socket size recommendations are based on torque output of tool and socket size range. Additional socket sizes available on request.

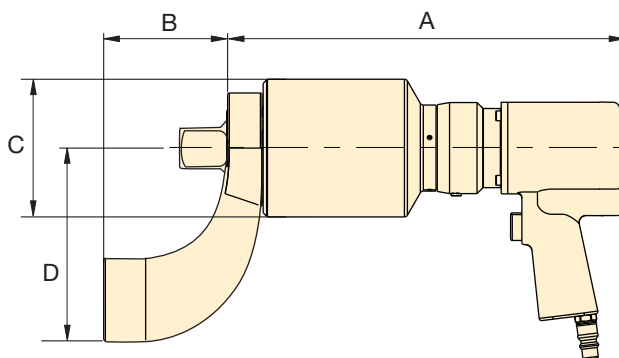

All tools are shipped complete with standard reaction arm and FRL*.

▼ SELECTION CHART

Minimum Torque		Maximum Torque		Square Drive (in)	Model Number*	RPM	Dimensions (in)				Weight** (lbs)
(ft-lbs)	(Nm)	(ft-lbs)	(Nm)				A	B	C	D	
300	407	1000	1356	1	PTW1000C	12.6	10.70	3.27	2.83	5.12	18
500	678	2000	2712	1	PTW2000C	8.0	11.26	3.27	3.11	5.24	19.5
900	1220	3000	4067	1	PTW3000C	3.1	13.50	3.27	3.74	5.24	23
1300	1763	6000	8135	1½	PTW6000C	2.5	14.40	4.49	5.00	7.00	39

* To order without FRL and hose, remove "C" Suffix (e.g. PTW3000).

** Weight does not include reaction arm. Reaction arm weight for PTW1000, PTW2000, PTW3000 is 2.9 lbs. and PTW6000 is 7.75 lbs.

PTW Series



Maximum Output Torque:

6000 Ft.lbs

Square Drive Range:

1 - 1½ inch



Pneumatic Torque Wrench Accessories

Enerpac offers a full line of accessories including a range of reaction arms and drives.

Page: **36**



Filter-Regulator-Lubricator

Recommended for use with all PTW pneumatic torque wrenches. Provides clean, lubricated air and allows for air pressure adjustment.

Order model number

FRL120C



BSH-Series Sockets

Heavy-Duty Impact Sockets for power driven torquing equipment.

Page: **10**



Hydraulic Torque Wrenches

Enerpac offers a complete range of square drive and hexagon cassette torque wrenches.

Page: **6 & 12**



PTW-Series Torque Wrenches

Enerpac offers the following accessories to support a wide variety of applications in industries such as mining, power generation and oil and gas. For additional custom accessories not pictured here, please contact Enerpac.

PTW-Series



Maximum Output Torque:

6000 Ft.lbs

Square Drive Range:

1 - 1½ inch

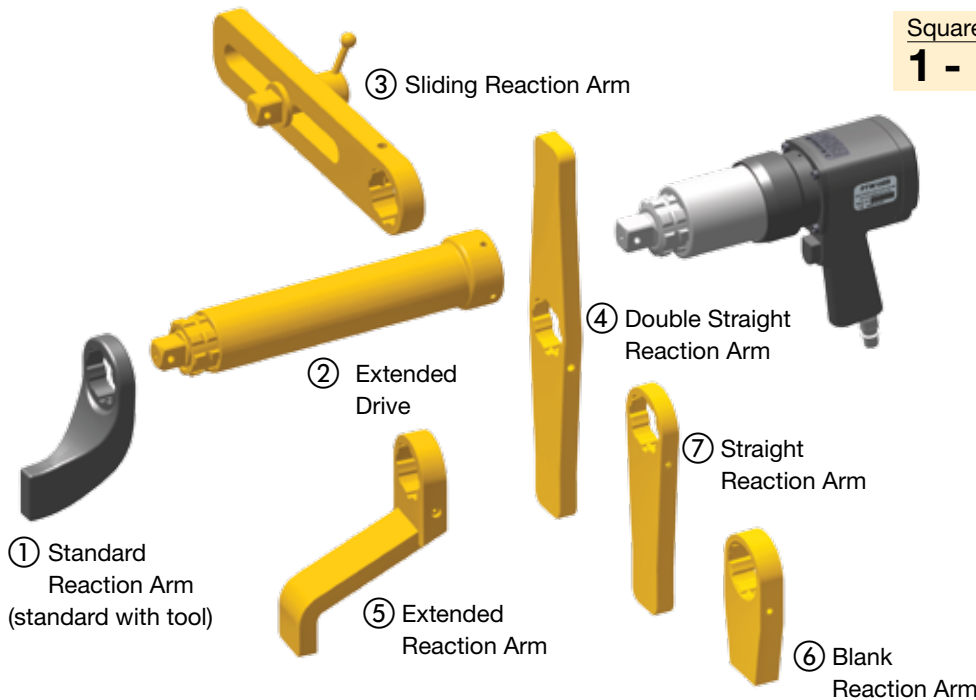

▼ PTW-SERIES OPTIONAL ACCESSORIES

▼ For use with PTW1000, PTW2000, PTW3000 models			
No.	Description	Model No.	Application
1	Standard Reaction Arm	RATWS	Standard arm included with PTW model
2	Extended Drive, 6 inch	ED6TWS	152 mm nose extension, primarily for truck wheel bolts
2	Extended Drive, 12 inch	ED12TWS	305 mm nose extension, primarily for truck wheel bolts
2	Extended Drive, 18 inch	ED18TWS	457 mm nose extension, primarily for truck wheel bolts
3	Sliding Reaction Arm	SLRATWS	For widely spaced and uneven bolt centers
4	Double Straight Reaction Arm	DSATWS	Reduces time to reposition arm *
5	Extended Reaction Arm	ERATWS	Long plate for use with deep well sockets
6	Blank Reaction Arm	BLTWS	Weldable blank for custom applications **
7	Straight Reaction Arm	SRATWS	Long plate for wide spaced reaction points
▼ For use with PTW6000 models			
1	Standard Reaction Arm	RATWL	Standard arm included with PTW model
2	Extended Drive 6 inch	ED6TWL	152 mm nose extension, primarily for truck wheel bolts
2	Extended Drive 12 inch	ED12TWL	305 mm nose extension, primarily for truck wheel bolts
3	Sliding Reaction Arm	SLRATWL	For widely spaced and uneven bolt centers
4	Double Straight Arm	DSATWL	Reduces time to reposition arm *
5	Extended Reaction Arm	ERATWL	Long plate for use with deep well sockets
6	Blank Reaction Arm	BLTWL	Weldable blank for custom applications **
7	Straight Reaction Arm	SRATWL	Long plate for wide spaced reaction points

* Time to reposition arm when repeatedly moving from tightening to loosening.

** Blank reaction arms must be heat treated to HRc 38-42 prior to use.

Typical PTW-Series Torque Wrench Applications

Mining

- Track maintenance
- Undercarriage maintenance
- Wheel maintenance
- Shovel maintenance



Power Generation

- Turbine bolts
- Tower segments
- Turbine casings



Oil & Gas

- Pipe flanges
- Valves
- Manway covers
- Pressure vessels