

OPERATION AND PARTS MANUAL



Mikasa SERIES
MODEL MVH308DZ
REVERSIBLE PLATE COMPACTOR
(HATZ 1B30 DIESEL ENGINE)

Revision #2 (08/03/16)

To find the latest revision of this
publication, visit our website at:
www.multiquip.com



THIS MANUAL MUST ACCOMPANY THE EQUIPMENT AT ALL TIMES.



CALIFORNIA — Proposition 65 Warning

Diesel engine exhaust and some of its constituents are known to the State of California to cause cancer, birth defects and other reproductive harm.

TABLE OF CONTENTS

MVH308DZ Reversible Plate Compactor

Proposition 65 Warning	2
Table Of Contents	4
Parts Ordering Procedures.....	5
Safety Information	6-10
Specifications	11
Dimensions.....	12
General Information.....	13
Components	14-15
Basic Engine.....	16
Inspection	17-19
Startup.....	20-21
Operation.....	22-23
Maintenance	24-30
Troubleshooting (Compactor)	31
Troubleshooting (Engine).....	32-33
Explanation Of Code In Remarks Column.....	34
Suggested Spare Parts	35

Compactor Component Drawings

Vibrating Plate Assembly.....	36-37
Vibrator Assembly	38-39
Base And Engine Assembly	40-41
Electric Device Assembly	42-47
Control Assembly	48-51
Nameplate And Decals Assembly	52-53

Hatz 1B30 Engine Component Drawings

Spare Parts Kit Assembly.....	54-55
Accessories Assembly.....	56-57
Crankcase Assembly.....	58-59
Crankshaft Assembly.....	60-61
Camshaft Assembly.....	62-63
Piston, Connecting Rod, Cylinder Assembly	64-65
Cylinder Head Assembly.....	66-69
Oil Pump, Governor Assembly	70-71
Timing Cover Assembly	72-75
Blower, Flywheel Assembly	76-77
Injection Equipment Assembly	78-81
Recoil Starter Assembly	82-83
Air Ducting Assembly	84-87
Crankcase Breathing System Assembly	88-89
Fuel Assembly	90-93
Air Filter Assembly.....	94-95
Exhaust Silencer Assembly	96-97
Starter, Alternator Assembly.....	98-99
Speed Control Assembly	100-101
Spec. Equipment EPA Assembly	102-103
Electric Equipment, Wiring Assembly.	104-105

Terms And Conditions Of Sale — Parts	106
--	-----

NOTICE

Specifications and part numbers are subject to change without notice.

PARTS ORDERING PROCEDURES

Ordering parts has never been easier! Choose from three easy options:

Effective:
January 1st, 2006

www.multiquip.com



Order via Internet (Dealers Only):

Order parts on-line using Multiquip's SmartEquip website!

- View Parts Diagrams
- Order Parts
- Print Specification Information



If you have an MQ Account, to obtain a Username and Password, E-mail us at: parts@multiquip.com.

To obtain an MQ Account, contact your District Sales Manager for more information.

Goto www.multiquip.com and click on **Order Parts** to log in and save!

Use the **internet** and qualify for a **5% Discount** on *Standard orders* for all orders which include complete part numbers.*

Note: Discounts Are Subject To Change

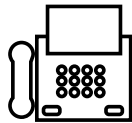

Order via Fax (Dealers Only):

All customers are welcome to order parts via Fax.

Domestic (US) Customers dial:
1-800-6-PARTS-7 (800-672-7877)

Fax your order in and qualify for a **2% Discount** on *Standard orders* for all orders which include complete part numbers.*

Note: Discounts Are Subject To Change



Order via Phone: Domestic (US) Dealers Call:
1-800-427-1244

Non-Dealer Customers:

Contact your local Multiquip Dealer for parts or call 800-427-1244 for help in locating a dealer near you.



International Customers should contact their local Multiquip Representatives for Parts Ordering information.

When ordering parts, please supply:

- | | |
|---|--|
| <input type="checkbox"/> Dealer Account Number | <input type="checkbox"/> Specify Preferred Method of Shipment: |
| <input type="checkbox"/> Dealer Name and Address | <input checked="" type="checkbox"/> UPS/Fed Ex <input checked="" type="checkbox"/> DHL |
| <input type="checkbox"/> Shipping Address (if different than billing address) | <input type="checkbox"/> Priority One <input checked="" type="checkbox"/> Truck |
| <input type="checkbox"/> Return Fax Number | <input type="checkbox"/> Ground |
| <input type="checkbox"/> Applicable Model Number | <input type="checkbox"/> Next Day |
| <input type="checkbox"/> Quantity, Part Number and Description of Each Part | <input type="checkbox"/> Second/Third Day |

NOTICE

All orders are treated as *Standard Orders* and will ship the same day if received prior to 3PM PST.

WE ACCEPT ALL MAJOR CREDIT CARDS!



SAFETY INFORMATION

Do not operate or service the equipment before reading the entire manual. Safety precautions should be followed at all times when operating this equipment. Failure to read and understand the safety messages and operating instructions could result in injury to yourself and others.



SAFETY MESSAGES

The four safety messages shown below will inform you about potential hazards that could injure you or others. The safety messages specifically address the level of exposure to the operator and are preceded by one of four words: **DANGER**, **WARNING**, **CAUTION** or **NOTICE**.

SAFETY SYMBOLS

! DANGER

Indicates a hazardous situation which, if not avoided, **WILL** result in **DEATH** or **SERIOUS INJURY**.

! WARNING

Indicates a hazardous situation which, if not avoided, **COULD** result in **DEATH** or **SERIOUS INJURY**.







! CAUTION

Indicates a hazardous situation which, if not avoided, **COULD** result in **MINOR** or **MODERATE INJURY**.

NOTICE

Addresses practices not related to personal injury.

Potential hazards associated with the operation of this equipment will be referenced with hazard symbols which may appear throughout this manual in conjunction with safety messages.

Symbol	Safety Hazard
	Lethal exhaust gas hazards
	Explosive fuel hazards
	Burn hazards
	Respiratory hazards
	Accidental starting hazards
	Eye and hearing hazards
	Rotating parts hazards

SAFETY INFORMATION

GENERAL SAFETY

⚠ CAUTION

- **NEVER** operate this equipment without proper protective clothing, shatterproof glasses, respiratory protection, hearing protection, steel-toed boots and other protective devices required by the job or city and state regulations.



- **NEVER** operate this equipment when not feeling well due to fatigue, illness or when under medication.



- **NEVER** operate this equipment under the influence of drugs or alcohol.



- **ALWAYS** check the equipment for loosened threads or bolts before starting.
- **DO NOT** use the equipment for any purpose other than its intended purposes or applications.
- **ALWAYS** clear the work area of any debris, tools, etc. that would constitute a hazard while the equipment is in operation.

NOTICE

- This equipment should only be operated by trained and qualified personnel 18 years of age and older.
- Whenever necessary, replace nameplate, operation and safety decals when they become difficult read.
- Manufacturer does not assume responsibility for any accident due to equipment modifications. Unauthorized equipment modification will void all warranties.
- **NEVER** use accessories or attachments that are not recommended by Multiquip for this equipment. Damage to the equipment and/or injury to user may result.
- **ALWAYS** know the location of the nearest **fire extinguisher**.
- **ALWAYS** know the location of the nearest **first aid kit**.
- **ALWAYS** know the location of the nearest phone or **keep a phone on the job site**. Also, know the phone numbers of the nearest **ambulance**, **doctor** and **fire department**. This information will be invaluable in the case of an emergency.

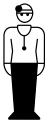

SAFETY INFORMATION

COMPACTOR SAFETY

DANGER

- **NEVER** operate the equipment in an explosive atmosphere or near combustible materials. An explosion or fire could result causing severe **bodily harm or even death.**



WARNING

- **NEVER** disconnect any **emergency or safety devices.** These devices are intended for operator safety. Disconnection of these devices can cause severe injury, bodily harm or even death. Disconnection of any of these devices will void all warranties.

CAUTION

- **NEVER** lubricate components or attempt service on a running machine.

NOTICE

- **ALWAYS** keep the machine in proper running condition.
- Fix damage to machine and replace any broken parts immediately.
- **ALWAYS** store equipment properly when it is not being used. Equipment should be stored in a clean, dry location out of the reach of children and unauthorized personnel.

ENGINE SAFETY

DANGER

- The engine fuel exhaust gases contain poisonous carbon monoxide. This gas is colorless and odorless, and can cause death if inhaled.
- The engine of this equipment requires an adequate free flow of cooling air. **NEVER** operate this equipment in any enclosed or narrow area where free flow of the air is restricted. If the air flow is restricted it will cause injury to people and property and serious damage to the equipment or engine.



WARNING

- **DO NOT** place hands or fingers inside engine compartment when engine is running.
- **NEVER** operate the engine with heat shields or guards removed.
- Keep fingers, hands hair and clothing away from all moving parts to prevent injury.
- **DO NOT** remove the radiator cap while the engine is hot. High pressure boiling water will gush out of the radiator and severely scald any persons in the general area of the compactor.
- **DO NOT** remove the coolant drain plug while the engine is hot. Hot coolant will gush out of the coolant tank and severely scald any persons in the general area of the compactor.
- **DO NOT** remove the engine oil drain plug while the engine is hot. Hot oil will gush out of the oil tank and severely scald any persons in the general area of the compactor.



CAUTION

- **NEVER** touch the hot exhaust manifold, muffler or cylinder. Allow these parts to cool before servicing equipment.



NOTICE

- **NEVER** run engine without an air filter or with a dirty air filter. Severe engine damage may occur. Service air filter frequently to prevent engine malfunction.
- **NEVER** tamper with the factory settings of the engine or engine governor. Damage to the engine or equipment can result if operating in speed ranges above the maximum allowable.
- **NEVER** tip the engine to extreme angles during lifting as it may cause oil to gravitate into the cylinder head, making the engine start difficult.





SAFETY INFORMATION

FUEL SAFETY

DANGER

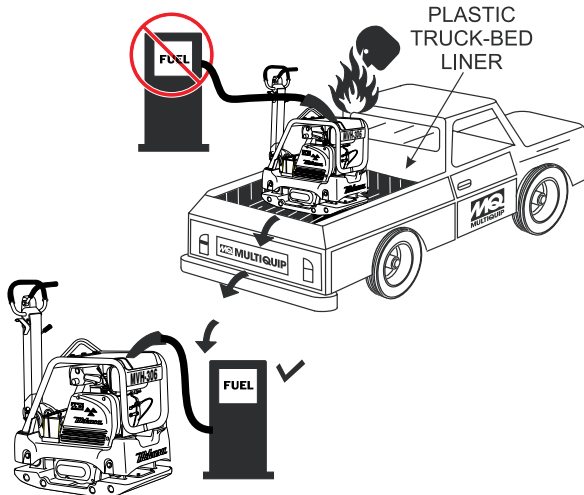
- **DO NOT** add fuel to equipment if it is placed inside truck bed with plastic liner. Possibility exists of explosion or fire due to static electricity.



- **DO NOT** start the engine near spilled fuel or combustible fluids. Diesel fuel is extremely flammable and its vapors can cause an explosion if ignited.
- **ALWAYS** refuel in a well-ventilated area, away from sparks and open flames.
- **ALWAYS** use extreme caution when working with **flammable** liquids.
- **DO NOT** fill the fuel tank while the engine is running or hot.
- **DO NOT** overfill tank, since spilled fuel could ignite if it comes into contact with hot engine parts or sparks from the ignition system.
- Store fuel in appropriate containers, in well-ventilated areas and away from sparks and flames.
- **NEVER** use fuel as a cleaning agent.
- **DO NOT** smoke around or near the equipment. Fire or explosion could result from fuel vapors or if fuel is spilled on a hot engine. 

BATTERY SAFETY (ELECTRIC START ONLY)

DANGER

- **DO NOT** drop the battery. There is a possibility that the battery will explode.
- **DO NOT** expose the battery to open flames, sparks, cigarettes, etc. The battery contains combustible gases and liquids. If these gases and liquids come into contact with a flame or spark, an explosion could occur. 

WARNING

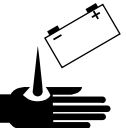
- **ALWAYS** wear safety glasses when handling the battery to avoid eye irritation. The battery contains acids that can cause injury to the eyes and skin. 
- Use well-insulated gloves when picking up the battery.
- **ALWAYS** keep the battery charged. If the battery is not charged, combustible gas will build up.
- **DO NOT** charge battery if frozen. Battery can explode. When frozen, warm the battery to at least 61°F (16°C).
- **ALWAYS** recharge the battery in a well-ventilated environment to avoid the risk of a dangerous concentration of combustible gases.
- If the battery liquid (dilute sulfuric acid) comes into contact with **clothing or skin**, rinse skin or clothing immediately with plenty of water. 
- If the battery liquid (dilute sulfuric acid) comes into contact with **eyes**, rinse eyes immediately with plenty of water and contact the nearest doctor or hospital to seek medical attention.

CAUTION

- **ALWAYS** disconnect the **NEGATIVE battery terminal** before performing service on the equipment.
- **ALWAYS** keep battery cables in good working condition. Repair or replace all worn cables.

SAFETY INFORMATION

TRANSPORTING SAFETY

CAUTION

- NEVER allow any person or animal to stand underneath the equipment while lifting.

NOTICE

- Before lifting, make sure that the equipment parts (hook and vibration insulator) are not damaged and screws are not loose or missing.
- Always make sure crane or lifting device has been properly secured to the lifting bail (hook) of the equipment.
- **ALWAYS** shutdown engine before transporting.
- **NEVER** lift the equipment while the engine is running.
- Tighten fuel tank cap securely and close fuel cock to prevent fuel from spilling.
- Use adequate lifting cable (wire or rope) of sufficient strength.
- Use one point suspension hook and lift straight upwards.
- **DO NOT** lift machine to unnecessary heights.
- **ALWAYS** tie down equipment during transport by securing the equipment with rope.

ENVIRONMENTAL SAFETY/DECOMMISSIONING

NOTICE

Decommissioning is a controlled process used to safely retire a piece of equipment that is no longer serviceable. If the equipment poses an unacceptable and unrepairable safety risk due to wear or damage or is no longer cost effective to maintain (beyond life-cycle reliability) and is to be decommissioned (demolition and dismantlement), be sure to follow rules below:

- **DO NOT** pour waste or oil directly onto the ground, down a drain or into any water source.
- Contact your country's Department of Public Works or recycling agency in your area and arrange for proper disposal of any electrical components, waste or oil associated with this equipment.



- When the life cycle of this equipment is over, remove battery and bring to appropriate facility for lead reclamation. Use safety precautions when handling batteries that contain sulfuric acid.
- When the life cycle of this equipment is over, it is recommended that the trowel frame and all other metal parts be sent to a recycling center.

Metal recycling involves the collection of metal from discarded products and its transformation into raw materials to use in manufacturing a new product.

Recyclers and manufacturers alike promote the process of recycling metal. Using a metal recycling center promotes energy cost savings.

EMISSIONS INFORMATION

NOTICE

The diesel engine used in this equipment has been designed to reduce harmful levels of carbon monoxide (CO), hydrocarbons (HC) and nitrogen oxides (NOx) contained in diesel exhaust emissions.

This engine has been certified to meet US EPA Evaporative emissions requirements in the installed configuration.

Attempting to modify or make adjustments to the engine emission system by unauthorized personnel without proper training could damage the equipment or create an unsafe condition.

Additionally, modifying the fuel system may adversely affect evaporative emissions, resulting in fines or other penalties.

Emission Control Label

The emission control label is an integral part of the emission system and is strictly controlled by regulations.

The label must remain with the engine for its entire life.

If a replacement emission label is needed, please contact your authorized Kohler Engine Distributor.

SPECIFICATIONS

Table 1. MVH308DZ Specifications	
Centrifugal Force	10,116 lbf (45 kN)
Vibration Frequency	4,400 vpm (73 Hz)
Maximum Traveling Speed	79 ft/min (24 m/min)
Plate Size (W x L)	17.52 x 33.86 in (445 x 860 mm)
Plate Size (W x L) with extension plates	23.62 x 33.86 in (600 x 860 mm)
Recommended Battery Types	Centennial 25-75, Interstate MT85, North Star NSB-AGM35, Oddesy PC1400/35
Battery Dimensions (LxWxH)	9.75 x 7 x 9 in. (248 x 178 x 229 mm)
Operating Weight	760.59 lbs. (345 kg.)
Operating Weight with extension plates	793.66 lbs. (360 kg.)

Table 2. Engine Specifications	
Engine Make	HATZ
Engine Model	1B30
Engine Type	Air-cooled, 4 Cycle Diesel Engine
Cylinder Bore X Stroke	3.15 x 2.72 in. (80 x 69 mm)
Displacement	21.18 cu-in (347 cc)
Maximum Output	6.6 BHP (4.9 kW) @ 3300 RPM
Fuel Tank Capacity	Approx. 1.4 U.S. gallons (5.3 liters)
Fuel Type	Diesel
Oil Capacity	1.16 qts (1.1 liters)
Starting Method	Recoil/Electric Start
Dry Net Weight	88.18 lbs (40 Kg.)

DIMENSIONS

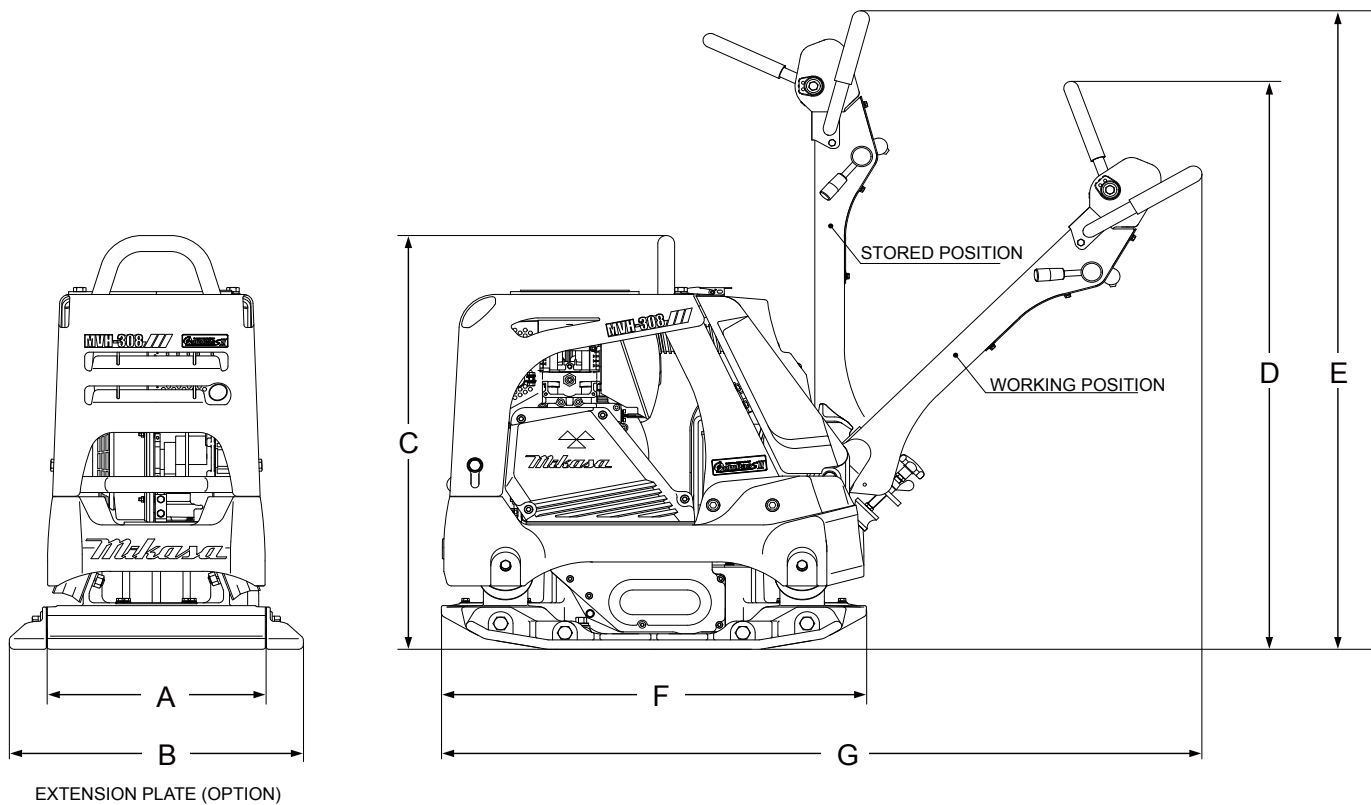

Figure 1. Dimensions

Table 3. Dimensions	
REF. DES	IN. (MM)
A	17.52 (445)
B	23.62 (600)
C	34.65 (880)
D	47.64 (1210)
E	53.54 (1360)
F	33.86 (860)
G	60.63 (1540)

GENERAL INFORMATION

DEFINITION OF PLATE COMPACTOR

The Mikasa MVH308DZ is a reversible plate compactor designed for efficient compaction of sand, gravel and cohesive soils. This plate compactor is a powerful compacting tool capable of applying a tremendous force in consecutive high frequency vibrations to a soil surface. Its applications include compacting for road, embankments and reservoirs as well as backfilling for gas pipelines, water pipelines and cable installation work.

VIBRATORY PLATES

The vibratory plates of the compactor produce low amplitude high frequency vibrations, designed to compact granular soils and asphalt.

The resulting vibrations cause forward motion. The engine and handle are vibration isolated from the vibrating plate.

FREQUENCY/SPEED

The compactor's vibrating plate produces a vibration frequency of 4,400 VPM (vibrations per minute). The travel speed of the compactor is approximately 79 ft/minute (24 meters/minute).

ENGINE

This plate compactor is equipped with a Hatz 1B30 air cooled, 4-cycle diesel engine. The engine drives an eccentric weight at a high speed to develop a compaction force.

NOTICE

The MVH308DZ plate compactor is shipped from the factory **without the battery**. Battery can be purchased locally. Reference Table 1 for battery specifications.

CONTROLS

Before starting the plate compactor identify and understand the function of all the controls and components.

COMPONENTS

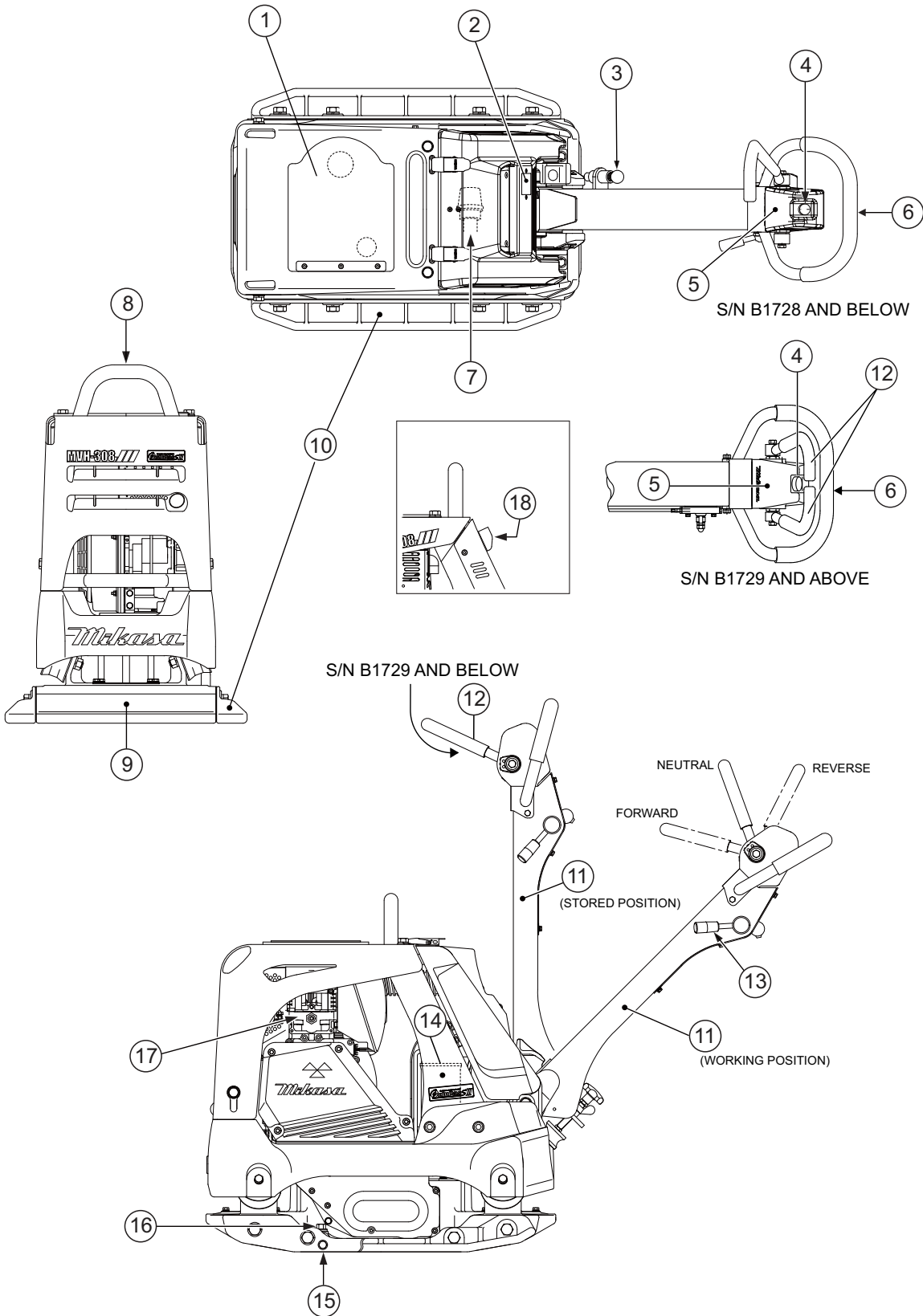

Figure 2. Plate Compactor Components

COMPONENTS

Figure 2 shows the location of the basic controls and components of the MVH308DZ Plate Compactor. The function of each control is described below:

1. **Rubber Cover** — Lift this rubber cover to gain access to the fuel tank.
2. **Hour/Tachometer** — Displays the cumulative time that the machine has been in use. During operation it displays the rpm reading. The tachometer also has a battery checker that lights red when the charge is low.
3. **Handle Bar Height Adjuster** — Adjusts the handle bar to the desired height by loosening the wing nut and turning the grip clockwise to raise the handle bar and counterclockwise to lower the handle bar.
4. **Breather Plug** — Allow pressure to escape to the air in the form of a gas from heat.
5. **Hydraulic Pump (Oil Reservoir)** — Regulates hydraulic oil flow produced by the direction of the control lever.
6. **Hand Grip** — When operating the compactor use this hand grip to maneuver the compactor.
7. **Cyclone Cleaner** — Filters large dust particles to keep air cleaner from getting clogged easily.
8. **Lifting Bale** — When lifting of the compactor is required either by forklift, crane etc., tie rope or chain around this lifting point.
9. **Vibrating Plate** — A flat, open plate made of durable cast iron construction used in the compacting of soil.
10. **Extension Plate** — Provides additional area of vibration to the vibrating plate.
11. **Handle Bar** — When operating the compactor, this handle is to be in the downward position. When the compactor is to be **stored**, move the handle bar to the upright position.
12. **Direction Control Lever** — *Push* the lever forward to move compactor in a forward direction. *Pull* the lever backwards to move compactor in backwards direction. Placing the lever in the middle (midway) will cause the compactor not to move (neutral).
13. **Throttle Lever** — Controls speed of the plate compactor. Place straight vertically to start, **push** fully counterclockwise for full throttle and fully clockwise to stop plate compactor.
14. **Battery** — Provides +12V DC to the electrical system.
15. **Vibrator Oil Drain Plug** — Used to drain vibrator oil from the machine.
16. **Vibration Case Oil Filler** — Used to add oil to the vibration case.
17. **Engine** — This plate compactor uses a Hatz 1B30 diesel engine. Refer to the owner's manual for engine information.
18. **Engine ON/OFF Switch** — Used to turn the engine on or off.

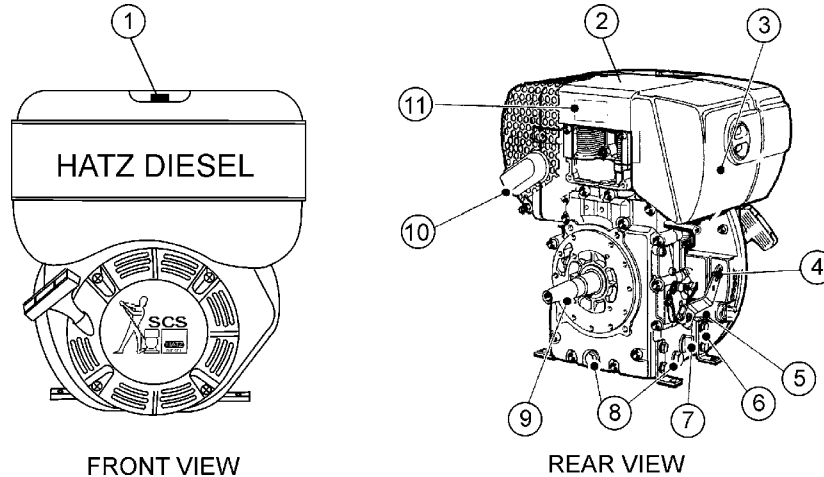

Figure 3. Engine Controls and Components

INITIAL SERVICING

The engine (Figure 3) must be checked for proper lubrication and filled with fuel prior to operation. Refer to the manufacturer's Engine manual for operating and servicing information.

1. **Fuel Filler Cap/Fuel Tank** — Pull this latch to add **diesel** fuel to the tank. After refueling, always make sure the fuel cap is latched properly. **DO NOT** over fill. For additional information refer to engine owner's manual.

DANGER



Adding fuel to the tank should be done only when the engine is stopped and has had an opportunity to cool down. In the event of a fuel spill, **DO NOT** attempt to start the engine until the fuel residue has been completely wiped up, and the area surrounding the engine is dry.

2. **Engine Lifting Straps/Cover** — Remove the air cleaner cover, then lift this cover (the one with decals on it) to gain access to the engine lifting straps.
3. **Air Cleaner/Cover** — Prevents dirt and other debris from entering the fuel system. Remove wing-nut on side of air filter cover to gain access to filter element.
4. **Speed Control Lever** — This lever is connected to the throttle control which is located on the side of the engine compartment cover. Use this lever to control engine speed.
5. **Dipstick** — Remove dipstick to determine if the engine oil level is low. If low, add oil as specified.

6. **Engine Motor Mounts** — Attach these engine mounts to the pump frame. Tighten securely.
7. **Oil Filter** — Remove this bolt to gain access (internal) to the engine oil filter. Service the oil filter as recommended in the maintenance section of this manual.
8. **Oil Drain Plugs** — There are two oil drain plugs, one is underneath the flywheel, the other on the side of the engine. Remove these plugs to drain engine oil from the engine crankcase.
9. **Crankshaft** — Connect this shaft to the input of the transmission.
10. **Muffler** — Used to reduce noise and emissions.
11. **Nameplate** — Contains information about the engine.

NOTICE

Operating the engine without an air filter, with a damaged air filter, or a filter in need of replacement will allow dirt to enter the engine, causing rapid engine wear.

WARNING



Engine components can generate extreme heat. To prevent burns, **DO NOT** touch these areas while the engine is running or immediately after operating. **NEVER** operate the engine with the muffler removed.

BEFORE STARTING

1. Read all safety instructions at the beginning of manual.
2. Clean the compactor, removing dirt and dust, particularly the engine cooling air inlet, carburetor and air cleaner.
3. Check the air filter for dirt and dust. If air filter is dirty, replace air filter with a new one as required.
4. Check carburetor for external dirt and dust. Clean with dry compressed air.
5. Check fastening nuts and bolts for tightness.

ENGINE OIL CHECK

1. To check the engine oil level, place the compactor on secure level ground with the engine stopped. If the oil level is low, add oil (Grade CC or above).
2. Lubrication is done from the top of the engine (Figure 4).

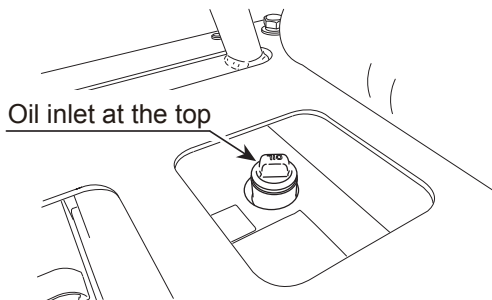

Figure 4. Adding Engine Oil

NOTICE

Pour oil slowly from the top. Oil might overflow if large amount of oil is poured right away.

Table 4. Oil Type

Season	Temperature	Oil Type
Summer	25°C or Higher	SAE 10W-30
Spring/Fall	25°C~10°C	SAE 10W-30/20
Winter	0°C or Lower	SAE 10W-10

DANGER



EXPLOSIVE FUEL!

Motor fuels are highly flammable and can be dangerous if mishandled. **DO NOT** smoke while refueling. **DO NOT** attempt to refuel the compactor if the engine is hot! or running.

FUEL CHECK

1. The fuel tank cap is equipped with a lock lever. Unlock the lever before opening cap (Figure 5).

Lock lever Fuel tank cap

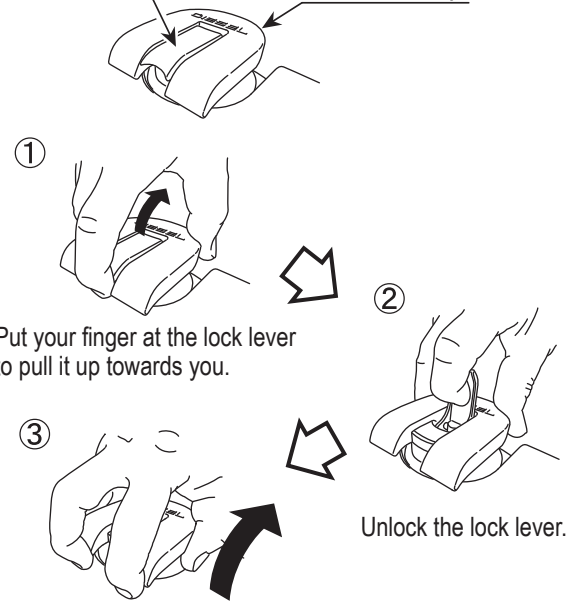

Put your fingers to the tabs at the two locations of the tank cap to pull up towards you.

Figure 5. Unlocking Fuel Cap Lever

1. Visually inspect to see if fuel level is low. If fuel is low, replenish with unleaded fuel. Fuel inlet is located under the rubber cover at the front cover top portion.
2. When refueling, be sure to use a strainer for filtration. **DO NOT** top-off fuel. Wipe up any spilled fuel immediately.

V-BELT COVER REMOVAL

To inspect the V-belt, remove the three bolts that secure the belt cover to the frame as shown in Figure 6.

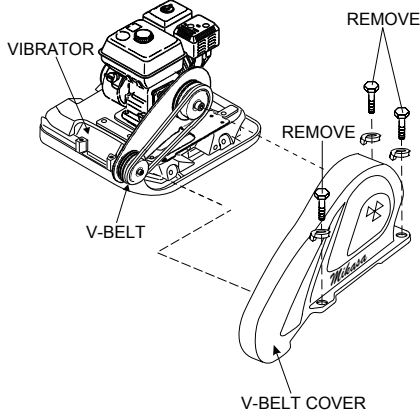

Figure 6. V-Belt Cover Removal

V-BELT INSPECTION

Visually examine the V-belt (Figure 7) and determine if it is full of tiny cracks, frayed, has pieces of rubber missing, is peeling or otherwise damaged.

Also, examine the belt and determine if it is **oil soaked** or **"glazed"** (hard shiny appearance on the sides of the belt). Either of these two conditions can cause the belt to run hot, which can weaken it and increase the danger of it breaking.

If the V-belt exhibits any of the referenced wear conditions replace the V-belt immediately

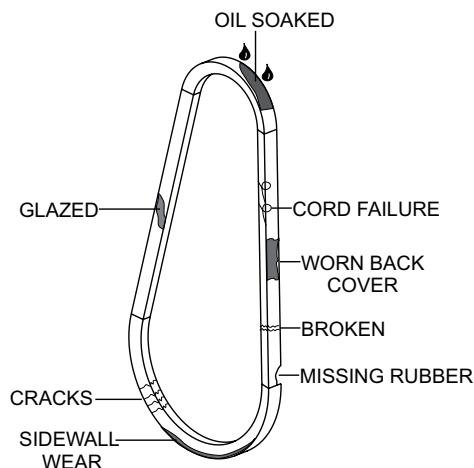

Figure 7. Drive Belt Inspection

V-BELT TENSION

The V-belt tension is proper if the V-belt bends 10 to 15 mm (Figure 8) when depressed with finger at midway between the clutch and vibrator pulleys.

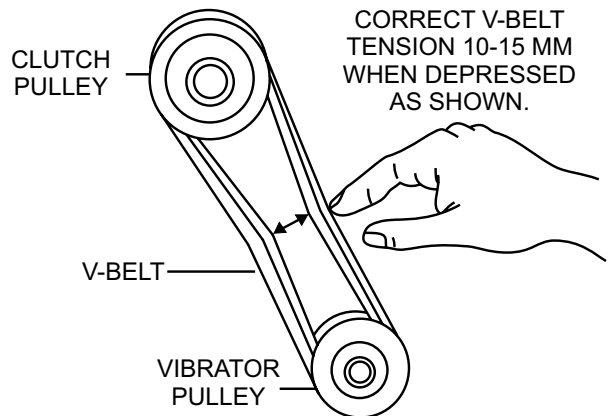

Figure 8. V-Belt Tension

VIBRATOR OIL CHECK

1. Place the plate compactor horizontally on a flat surface. Make sure the compactor is level when checking the oil in the vibrator assembly.
2. Check vibrator oil level by removing the oil plug (vibrator oil gauge) as shown in Figure 9. Clean the oil gauge and re-thread back in. Remove the oil gauge again and confirm oil level does not exceed the cross hash of the oil plug. **DO NOT OVERFILL!**
3. The vibrator holds approximately 20.3 oz. (600 cc). **IMPORTANT**, if oil is required, replace using only SAE 10W-30 motor oil.

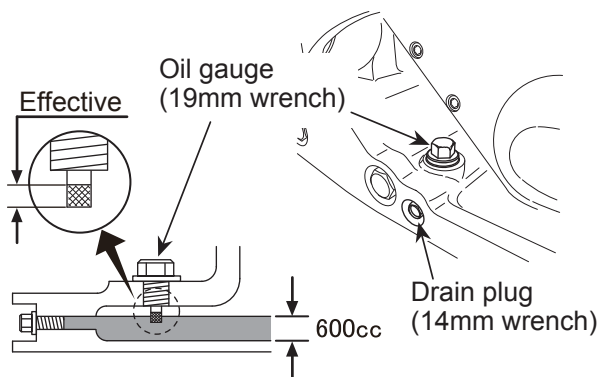

Figure 9. Vibrator Oil Check

HANDLE BAR

The height of the handle bar can be adjusted for ease of use. Adjust the handle height as follows. Refer to Figure 10.

1. Loosen the wing nut.
2. Turn the grip clockwise to raise the handle or counterclockwise to lower the handle.
3. When the handle bar is raised to the desired height, tighten the wing nut.

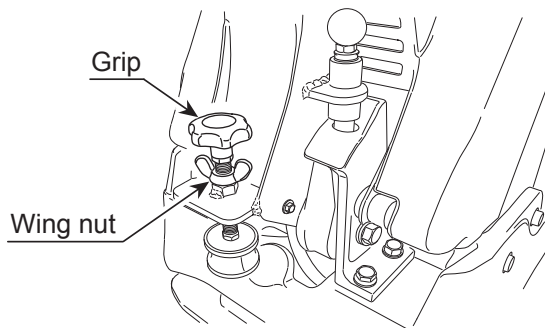



Figure 10. Handle Height Adjustment

CAUTION



DO NOT attempt to operate the compactor until the Safety, General Information and Inspection sections of this manual have been *read and thoroughly understood*.

This section is intended to assist the operator with the initial startup of the compactor. It is extremely important that this section be read carefully before attempting to use the compactor in the field.

STARTING THE ENGINE

Electric Start

1. Insert the key to the key switch.
2. Move the throttle lever (Figure 11) to the **idle** position.

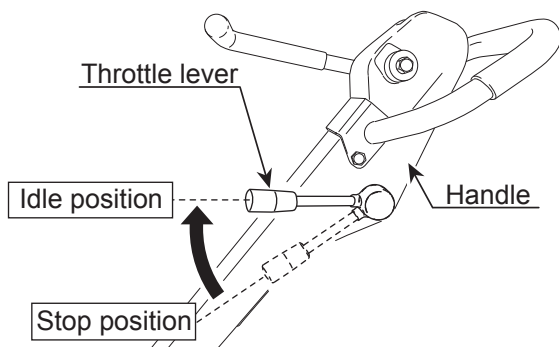

Figure 11. Throttle Lever (Idle Position)

3. Turn the key to the "Run" position (Figure 12). The buzzer sounds.

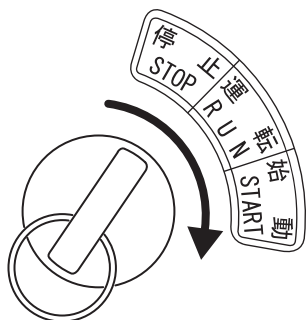
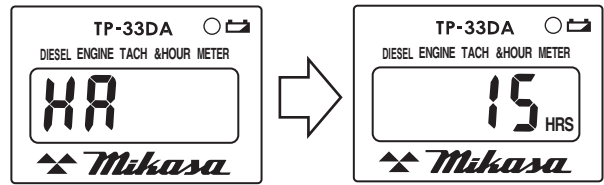

Figure 12. Key Positions

4. After "HA" is displayed on the hour tachometer, the display will change immediately to "cumulative time" (Figure 13).



"HA" is displayed at the operation position, then immediately it will change to "Cumulative time".

Figure 13. Hour Tachometer (Cumulative Time)

5. Turn the key further to the "Start" position to start the engine. When the engine starts, let go of the key. When the engine revolution increases, the buzzer stops.
6. When the engine is in operation, the Hour Tachometer display will show the "rotation number" (Figure 14).

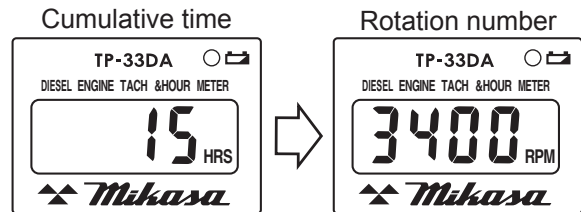

Figure 14. Hour Tachometer (Rotation Number)

7. After the engine has started, warm up the engine at low speed for 2 to 3 minutes, especially in cold weather.

CAUTION

When the engine does not start, do not run the cell motor continuously for more than 5 seconds. Move the key back to the "Run" position then wait about 10 seconds to restart.

While the engine is running, never turn the key switch to the "Start" position.

Recoil Start

1. Insert the key to the key switch.
2. Move the throttle lever (Figure 11) to the *idle* position.
3. Turn the key to the "Run" position (Figure 12). The buzzer sounds.
4. After "HA" is displayed on the hour tachometer, the display will change immediately to "cumulative time"
5. Grasp the starter grip (Figure 15) and slowly pull it out. The resistance becomes the hardest at a certain position, corresponding the compression point. Rewind the rope a little from that point and pull out sharply.

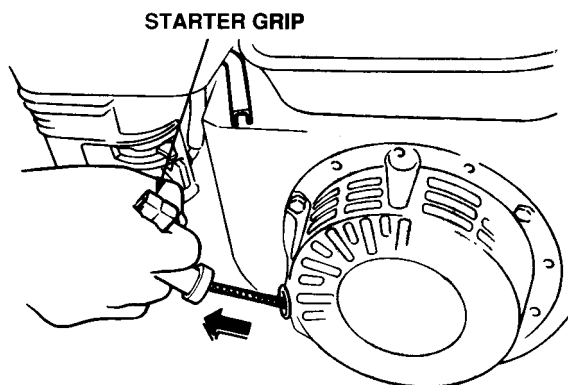

Figure 15. Starter Grip

NOTICE

DO NOT pull the starter rope all the way to the end.

DO NOT release the starter rope after pulling. Allow it to rewind as slow as possible.

6. When engine starts, release the starter grip and allow the rope to recoil.
7. After the engine has started, warm up the engine at low speed for 2 to 3 minutes, especially in cold weather.
8. Before the compactor is placed in to operation, run the engine for several minutes. Check for fuel leaks, and noises that would associate with a lose component.

OPERATION

CAUTION



ALWAYS follow all safety rules in the safety section of this manual before operating compactor. Keep work area clear of debris and other objects that could cause bodily injury or damage to the compactor.

1. Once the engine has started, move the engine throttle lever quickly to the **operation** position (Figure 16).

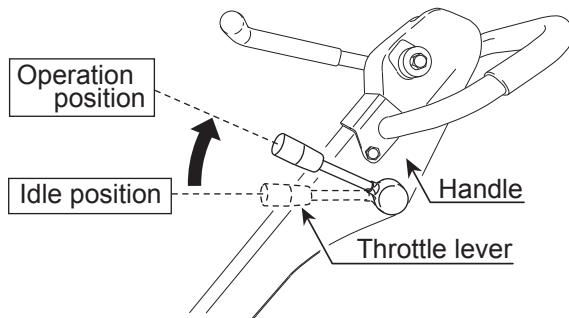

Figure 16. Throttle Lever (Operation Position)

2. With the throttle lever in the run position, the engine speed should be around 2,300 RPM, therefore engaging the centrifugal clutch.

NOTICE

ALWAYS move the throttle lever quickly without hesitation, because increasing the engine speed slowly causes the clutch to slip.

3. The direction control lever allows the machine to be moved either backward or forward (Figure 17). When the direction control lever is pushed forward, the machine moves forward. When pulled backward, the machine moves backward.

NOTICE

Your unit may be equipped with direction control levers on both the right and left side of the handle. Earlier models only have one control lever located on the right side of the handle.

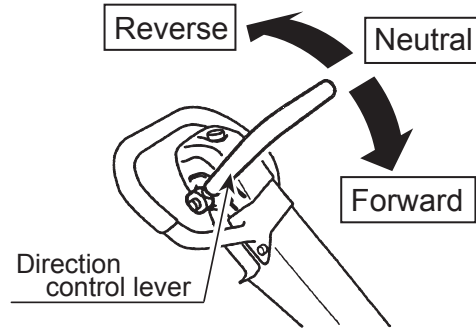

Figure 17. Direction Control Lever

4. When the direction control lever is the neutral position, the machine vibrates staying at the same location

NOTICE

NEVER stop the engine suddenly while working at high speeds.

5. Compactor traveling speed may drop on soils which contain clay, however there may be cases where traveling speed drops because the compaction plate does not leave the ground surface easily due to the composition of the soil. To rectify this problem do the following:
 - Check the bottom plate to see if clay or equivalent material has been lodge in the plate mechanism. If so, wash with water and remove.
 - Remember the compactor does not work as efficiently on clay or soils that have a high moisture content level.
 - If the soil has a high moisture level, dry soil to appropriate moisture content level or carry out compaction twice.

STOPPING THE ENGINE

Normal Shutdown

1. Move the throttle lever to the *idle* position (Figure 18) and run the engine for three minutes at low speed.

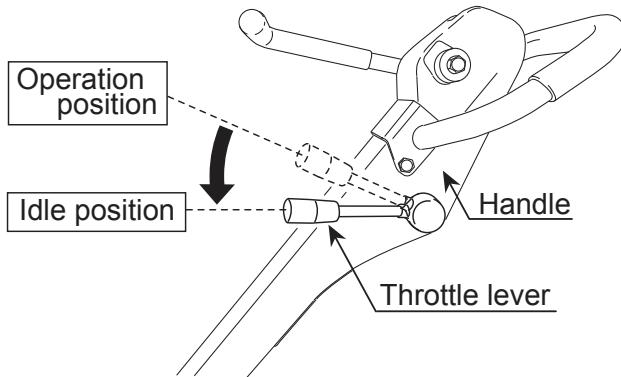

Figure 18. Throttle Lever (Idle)

2. Move the throttle lever (Figure 19) to the "Stop" position to stop the engine. The buzzer will sound.

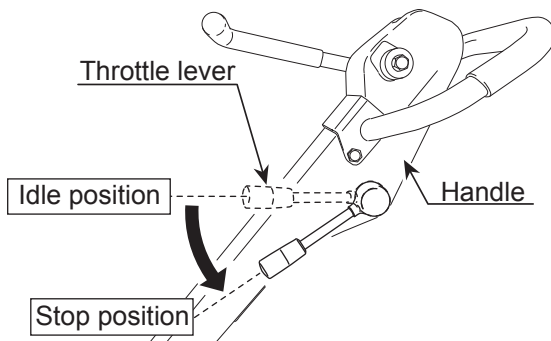

Figure 19. Throttle Lever (Stop Position)

3. Turn the key to the "Stop" position (Figure 20). The buzzer will stop.

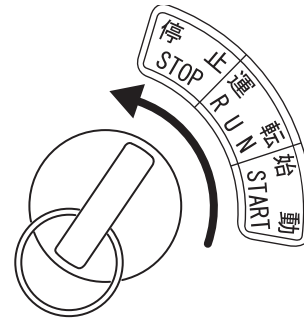

Figure 20. Key Switch (Stop)

Emergency Shutdown

1. Move the throttle lever quickly to the **IDLE** position, and turn the key to the "Stop" position.

GENERAL MAINTENANCE

General maintenance practices are crucial to the performance and longevity of your compactor. This equipment requires routine cleaning, inspection and lubrication. Reference Table 5 and Table 6 for scheduled engine and compactor maintenance.

The following procedures, devoted to maintenance, can prevent serious compactor damage or malfunctioning.

NOTICE

Reference **HATZ** engine manual supplied with your compactor for more detailed engine maintenance and troubleshooting.

CAUTION



ALWAYS allow the engine to cool before servicing. **NEVER** attempt any maintenance work on a hot engine.

WARNING



Some maintenance operations may require the engine to be run. Ensure that the maintenance area is well ventilated. Diesel engine exhaust contains poisonous carbon monoxide gas that can cause unconsciousness and may result in **DEATH**

General Cleanliness

Clean the compactor daily. Remove all dust and debris buildup (mud, clay etc.). If the compactor is steam-cleaned, ensure that lubrication is accomplished **AFTER** steam cleaning.

NOTICE

Inspection and other services should always be carried out on hard and level ground with the engine shutdown.

NOTICE

The inspection intervals listed in the maintenance tables are for operation under normal conditions. Adjust your inspection intervals based on the number hours plate compactor is in use, and particular working conditions.

To make sure your plate compactor is always in good working condition before using, carry out the maintenance inspection in accordance with Table 5 and Table 6.

ENGINE MAINTENANCE

Perform engine maintenance as listed in Table 5.

Table 5. Engine Maintenance Schedule							
Description (3)	Operation	Before	First Month or 10 hrs	Every 3 Months or 25 hrs	Every 6 Months or 50 hrs	Every Year or 100 hrs	Every 2 Years or 200 hrs
Engine Oil	CHECK	X					
	CHANGE		X				
Air Cleaner	CHECK	X					
	CHANGE			X (1)			
All Nuts and Bolts	Re-tighten If Necessary	X					
Cooling Fins	CHECK				X		
Fuel Tank	CLEAN					X	
Fuel Filter	CHECK					X	
Idle Speed	CHECK-ADJUST					X (2)	
Valve Clearance	CHECK-ADJUST						X (2)
Fuel lines	CHECK	Every 2 years (replace if necessary) (2)					

1. Service more frequently when used in **DUSTY** areas.
2. These items should be serviced by your service dealer, unless you have the proper tools and are mechanically proficient. Refer to the **HATZ** Shop Manual for service procedures.
3. For commercial use, log hours of operation to determine proper maintenance intervals.

MACHINE INSPECTION

Perform machine inspection as listed in Table 6.

Interval	Check	Solution
Daily Before Starting	Machine	Clean if necessary.
	Fuel Tank For Leaks	Repair fuel leaks.
	Fuel System for Leaks	Repair fuel leaks.
	Engine Oil	Add oil if necessary.
	Vibrator Oil	Add oil if necessary.
	Air Cleaner Element	Clean/Replace
	Guard Frame	Inspect/deformations
	Shock Absorber	Replace if damaged.
	Hydraulic Pump	Check/Repair Leaks
	Hydraulic Pipe System	Check/Repair leaks, Inspect for wear
	Direction Control Lever	Check bolts/nuts, Inspect for wear
Duct Hose	Check for crack/damage	
Every 20 Hours	Engine Oil/Oil Filter	Replace only after first 20 hrs.
Every 100 Hours	Engine Oil	Change
	Engine Oil Filter	Wash
	Vibrator Oil	Check oil level. Check for leaks/dirt.
	Hydraulic Oil	Check oil level. Check for leaks.
	Battery Terminal	Clean
Every 200 hours	V-Belt	Inspect, replace if damaged or worn.
	Clutch	Inspect, replace if not working properly.
	Engine Bolts	Replace bolts if deformed or elongated.
Every 300 hours	Vibrator Oil	Change
	Fuel Filter	Change
	Hydraulic Oil	Change
	Engine Oil Filter	Change
Every 2 years	Fuel Lines	Replace

TIGHTENING TORQUE

Reference Table 7 below (Tightening Torque), for retightening of nuts and bolts.

Material	6mm	8mm	10mm	12mm	14mm	16mm	18mm	20mm
4T	70	150	300	500	750	1,100	1,400	2,000
6-8T	100	250	500	800	1,300	2,000	2,700	3,800
11T	150	400	800	1,200	2,000	2,900	4,200	5,600
*	100 (6mm) 300 ~ 350 (8mm) 650 ~ 700 (10mm)							
**	In case counter-part is of aluminum							
Bolt threads used with this machine are all right handed								
Material and quality of material is marked on each bolt, and screw.								

ENGINE AIR CLEANER

CAUTION



Wear protective equipment such as approved safety glasses or face shields and dust masks or respirators when cleaning air filters with compressed air.

This engine is equipped with a replaceable, high-density paper air cleaner element. See Figure 21 for air cleaner components.

1. Remove the air cleaner cover and high-density paper air cleaner element (Figure 21).
2. Tap the paper filter element several times on a hard surface to remove dirt, or blow compressed air not exceeding 30 psi (207 kPa, 2.1 kgf/cm²) through the filter element from the inside out. **NEVER** brush off dirt. Brushing will force dirt into the fibers. Replace the paper filter element if it is excessively dirty.

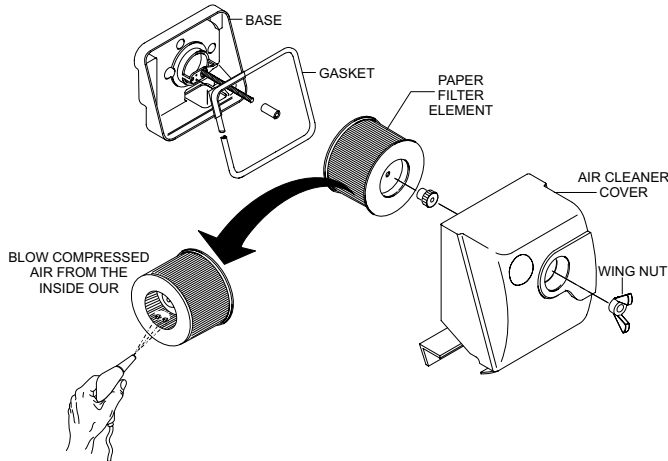

Figure 21. Engine Air Cleaner

NOTICE

Operating the engine with loose or damaged air cleaner components could allow unfiltered air into the engine causing premature wear and failure.

DUST POT

Always clean the dust pot. A clogged dust pot reduces cyclone effect with cleaner element wearing easily.

1. Release locking latch (Figure 22) on dust pot and remove dust pot from air cleaner body.

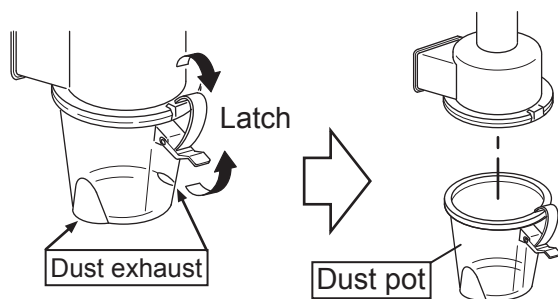

Figure 22. Unlatching Dust Pot

2. Clean dust pot with water and neutral detergent.

3. Reinstall dust pot onto air cleaner body and secure dust pot with locking latches (Figure 23).

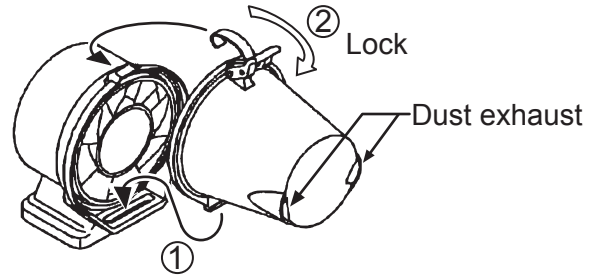

Figure 23. Latching Dust Pot

ENGINE OIL

NOTICE

Drain the engine oil when the oil is warm.

1. Remove the oil drain bolt (Figure 24), and sealing washer and allow the oil to drain into a suitable container.
2. Replace engine oil with recommended type oil as listed in Table 4. For engine oil capacity, see Table 2 (Engine Specifications). **DO NOT** overfill.
3. Reinstall drain bolt with sealing washer and tighten securely.

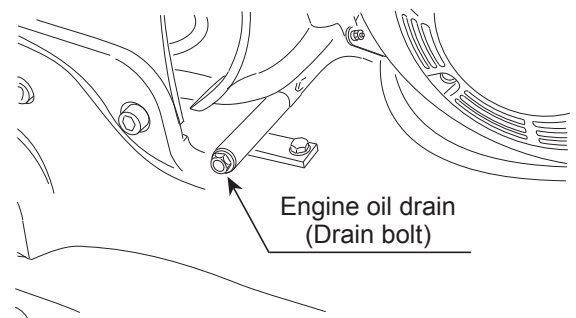

Figure 24. Draining Engine Oil

HYDRAULIC OIL

1. With the handle in vertical position, remove the plug cap from the hydraulic pump (Figure 25).

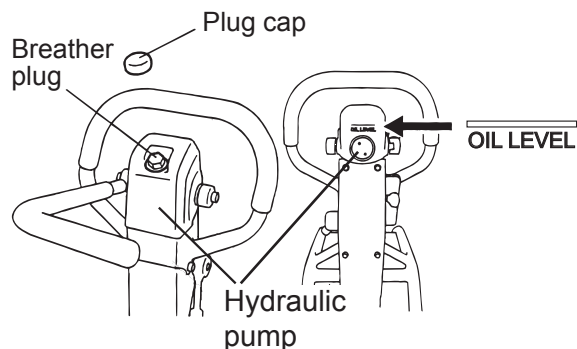

Figure 25. Removing Plug/Breather Cap

2. Remove the breather plug with a 24 mm wrench at the top of the hydraulic pump.
3. Remove the hydraulic hose connected to the cylinder on the vibrator side (Figure 26).

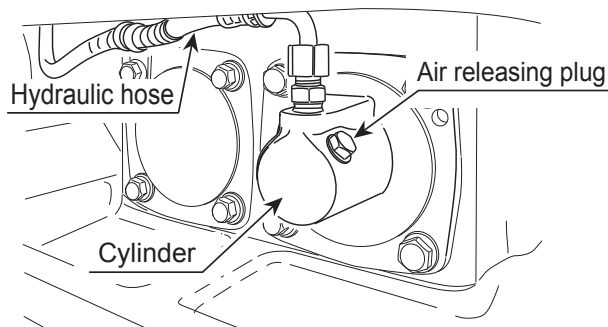

Figure 26. Removing Hydraulic Hose

4. Set the run lever to reverse.
5. Drain the hydraulic oil from the pump.
6. After the oil is drained, attach the hydraulic hose again to the cylinder on the vibrator side.

7. With the direction control lever at the forward-most position, secure the guard frame with a rope to immobilize (Figure 27).

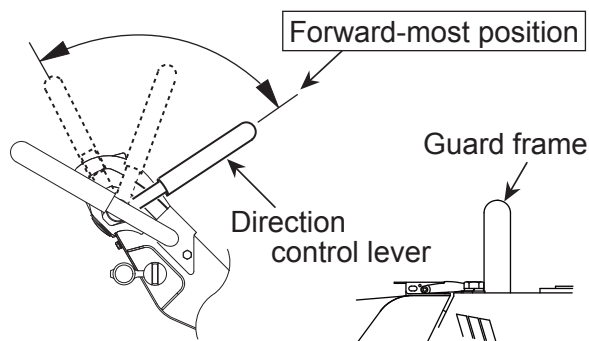

Figure 27. Direction Control Lever (Forward Position)

8. Pour hydraulic oil (550 cc) to the hydraulic pump breather plug attachment hole (Figure 25).
9. Remove the air releasing plug on vibrator cylinder. Oil will then come out from the air releasing plug. After air bubbles stop coming out, reinsert plug. Tighten securely (Figure 26).
10. Release the direction control lever and move the lever forward and reverse several times (until no air bubbles are seen). Keep the lever at the forward position for 10 seconds every time. (Because the check valve is opened at the maximum forward position and air bubble will come out from the oil tank of the hydraulic pump).
11. In case the air bleeding is insufficient, repeat steps 9 and 10.
12. Attach the hydraulic pump breather plug and put on the plug cap. After making sure the hydraulic oil in the pump is at OIL LEVEL, attach the breather plug.

CAUTION

Do not exceed OIL LEVEL of hydraulic oil. If the level is higher, oil will burst out from the breather plug.

V-BELT

Visually examine the V-belt (Figure 28) and determine if it is full of tiny cracks, frayed, has pieces of rubber missing, is peeling or otherwise damaged.

Also, examine the belt and determine if it is **oil soaked** or **"glazed"** (hard shiny appearance on the sides of the belt). Either of these two conditions can cause the belt to run hot, which can weaken it and increase the danger of it breaking.

If the V-belt exhibits any of the above wear conditions replace the V-belt immediately.

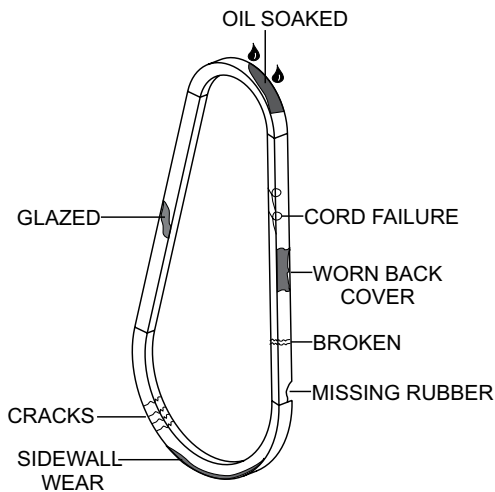

Figure 28. V-Belt Inspection

BATTERY

The standard battery installed is a maintenance-free battery. It is not necessary to supply battery fluid. In case of a sudden voltage drop, the battery cannot be charged quickly, so it has to be replaced with a new one.

Checking Battery Capacity

1. Check the battery checker on the hour tachometer (Figure 29).

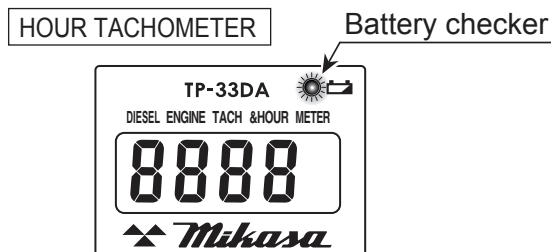

Figure 29. Battery Check

2. When the battery charge gets low, the battery checker lights red.

NOTICE

If an old battery is used, even when the battery checker is not lighted (indicating low charge), the cell starter might not operate because of low charging level. If that happens, change the battery with the new one.

Changing the Battery

1. Unlatch the two stoppers at the top portion of the rear cover to open the rear cover (Figure 30).

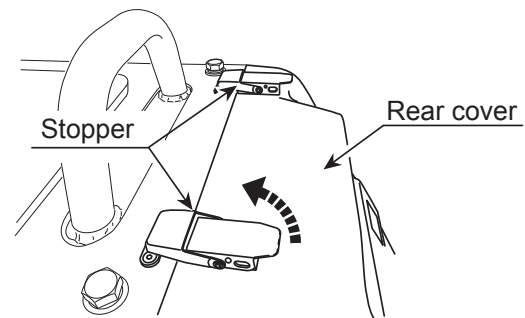

Figure 30. Opening Rear Cover

2. Loosen the two bolts on each side of the bar connecting the battery to the side rails (Figure 31).

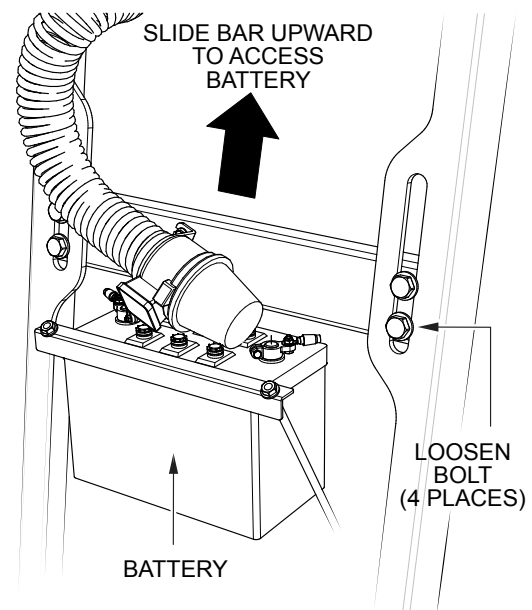

Figure 31. Raising The Battery

3. Slide the bar up the notches for easy access to the battery and tighten the bolts.
4. Take off the nuts and remove the battery holder (Figure 32).
5. After tilting the battery backward, disconnect the battery terminal. Always disconnect the black terminal on the negative side first.
6. Pull up the handle on the top of the battery to remove the battery from the machine (Figure 32). Make sure that the battery terminals do not touch the frame.

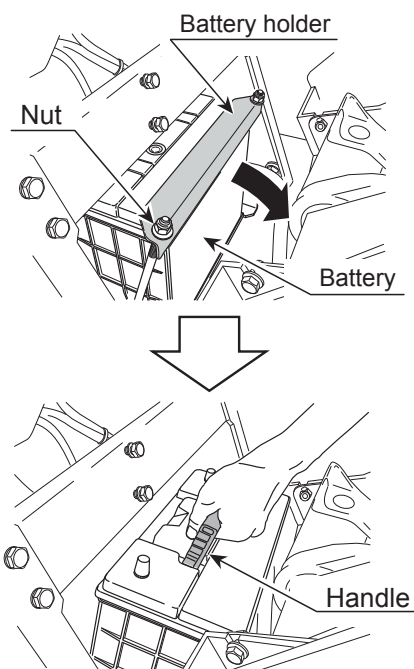

Figure 32. Removing Battery

7. To install new battery, perform the procedure in reverse. Make sure that the red terminal (positive side) is connected first.
8. Loosen the two bolts on each side of the battery bracket and slide the bracket down to lower the battery to its original location.
9. Tighten the four bolts.

STORAGE

1. Wash off dirt and soil from every part with water. While washing, be careful not to let the water splash on the electric components such as the battery and the engine muffler.
2. Cover the machine to prevent dust and dirt buildup.
3. Store the machine in a dry area away from direct sunlight.
4. Do not leave the machine outdoors. Keep it indoors.
5. When not used for a long period of time, drain the fuel from the fuel tank, and either disconnect the battery terminals or remove the battery itself.
6. When the machine is used after a long storage period, check the level of engine oil and battery capacity before using.

TROUBLESHOOTING (COMPACTOR)

Troubleshooting (Compactor)		
Symptom	Possible Problem	Solution
Travel speed low and vibration weak.	Clutch slips?	Adjust or replace clutch.
	V-belt slips?	Adjust or replace V-belt.
	Excessive oil in vibrator?	Fill to correct level.
	Trouble in vibrator internals?	Check vibrator assembly for any worn or defective parts, replace any defective parts.
	Aeration in hydraulic oil for for travel reversing system?	Purge air in hydraulic oil. (Bleed plug)
	Engine speed incorrect?	Set engine speed to correct RPM.
Travels forward or backward but unable to switch direction.	Hydraulic pump problems?	Check hydraulic pump.
	Direction Control Lever installation wrong?	Correct installation of IDirection Control Lever.
	Broken or defective oil hose?	Replace oil hose.
	Aeration in hydraulic oil?	Purge air in hydraulic oil. (Bleed plug)
	Excessive oil in reversing system?	Fill to correct level.
	Hydraulic pump clogged with trash?	Clean valve inside hydraulic pump.
	Cylinder piston bearing failure?	Check piston bearing in cylinder for leakage.
Does not travel in forward or reverse	V-belt disengaged or slips?	Engage V-belt, adjust or replace.
	Clutch slips?	Adjust clutch, replace if necessary.
	Vibrator locks?	Check vibrator and correct problem.
	Cylinder piston bearing failure?	Check piston bearing in cylinder for leakage at USH packing.
Direction Control Lever operating resistance for reverse is high.	Piston inside hydraulic pump not moving smoothly?	Adjust or replace.
	Vibrator cylinder piston does not move smoothly	Adjust or replace.

TROUBLESHOOTING (ENGINE)

Troubleshooting (Engine)		
Symptom	Possible Problem	Solution
Engine will not start or start is delayed, although engine can be turned over.	No Fuel reaching injection pump?	Add fuel. Check entire fuel system.
	Defective fuel pump?	Replace fuel pump.
	Fuel filter clogged?	Replace fuel filter and clean tank.
	Faulty fuel supply line?	Replace or repair fuel line.
	Compression too low?	Check piston, cylinder and valves. Adjust or repair per engine repair manual.
	Fuel pump not working correctly?	Repair or replace fuel pump.
	Oil pressure too low?	Check engine oil pressure.
	Low starting temperature limit exceeded?	Comply with cold starting instructions and proper oil viscosity.
	Defective battery?	Charge or replace battery.
	Air or water mixed in fuel system?	Check carefully for loosened fuel line coupling, loose cap nut, etc.
At low temperatures engine will not start.	Engine oil too thick?	Refill engine crankcase with correct type of oil for winter environment.
	Defective battery?	Replace battery.
Engine fires but stops soon as starter is switched off.	Fuel filter blocked?	Replace fuel filter.
	Fuel supply blocked?	Check the entire fuel system.
	Defective fuel pump?	Replace fuel pump.
Engine stops by itself during normal operation.	Fuel tank empty?	Add fuel.
	Fuel filter blocked?	Replace fuel filter.
	Defective fuel pump?	Replace fuel pump.
	Mechanical oil pressure shutdown sensor stops the engine due to low oil?	Add oil. Replace low oil shutdown sensor if necessary.
Low engine power, output and speed.	Fuel tank empty?	Replace fuel filter.
	Fuel filter clogged?	Replace fuel filter.
	Fuel tank venting is inadequate?	Ensure that tank is adequately vented.
	Leaks at pipe unions?	Check threaded pipe unions tape and tighten unions as required.
	Speed control lever does not remain in selected position?	See engine manual for corrective action.
	Engine oil level too full?	Correct engine oil level.
	Injection pump wear?	Use No. 2-D diesel fuel only. Check the fuel injection pump element and delivery valve assembly and replace as necessary.

TROUBLESHOOTING (ENGINE)

Troubleshooting (Engine) - continued		
Symptom	Possible Problem	Solution
Low engine power output and low speed, black exhaust smoke.	Air filter blocked?	Clean or replace air filter.
	Incorrect valve clearances?	Adjust valves per engine specification.
	Malfunction at injector?	See engine manual.
Engine overheats.	Too much oil in engine crankcase?	Drain off engine oil down to uppermark on dipstick.
	Entire cooling air system contaminated/ blocked?	Clean cooling air system and cooling fin areas.
	Fan belt broken or elongated?	Change belt or adjust belt tension.
	Coolant insufficient?	Replenish coolant.
	Radiator net or radiator fin clogged with dust?	Clean net or fin carefully.
	Fan, radiator, or radiator cap defective?	Replace defective part.
	Thermostat defective?	Check thermostat and replace if necessary.
Head gasket defective or water leakage?	Replace parts.	

EXPLANATION OF CODE IN REMARKS COLUMN

The following section explains the different symbols and remarks used in the Parts section of this manual. Use the help numbers found on the back page of the manual if there are any questions.

NOTICE

The contents and part numbers listed in the parts section are subject to change **without notice**. Multiquip does not guarantee the availability of the parts listed.

SAMPLE PARTS LIST

NO.	PART NO.	PART NAME	QTY.	REMARKS
1	12345	BOLT	1	INCLUDES ITEMS W/%
2%		WASHER, 1/4 IN.		NOT SOLD SEPARATELY
2%	12347	WASHER, 3/8 IN. ...	1	MQ-45T ONLY
3	12348	HOSE	A/R	MAKE LOCALLY
4	12349	BEARING	1	S/N 2345B AND ABOVE

NO. Column

Unique Symbols — All items with same unique symbol (@, #, +, %, or >) in the number column belong to the same assembly or kit, which is indicated by a note in the “Remarks” column.

Duplicate Item Numbers — Duplicate numbers indicate multiple part numbers, which are in effect for the same general item, such as different size saw blade guards in use or a part that has been updated on newer versions of the same machine.

NOTICE

When ordering a part that has more than one item number listed, check the remarks column for help in determining the proper part to order.

PART NO. Column

Numbers Used — Part numbers can be indicated by a number, a blank entry, or TBD.

TBD (To Be Determined) is generally used to show a part that has not been assigned a formal part number at the time of publication.

A blank entry generally indicates that the item is not sold separately or is not sold by Multiquip. Other entries will be clarified in the “Remarks” Column.

QTY. Column

Numbers Used — Item quantity can be indicated by a number, a blank entry, or A/R.

A/R (As Required) is generally used for hoses or other parts that are sold in bulk and cut to length.

A blank entry generally indicates that the item is not sold separately. Other entries will be clarified in the “Remarks” Column.

REMARKS Column

Some of the most common notes found in the “Remarks” Column are listed below. Other additional notes needed to describe the item can also be shown.

Assembly/Kit — All items on the parts list with the same unique symbol will be included when this item is purchased.

Indicated by:

“INCLUDES ITEMS W/(unique symbol)”

Serial Number Break — Used to list an effective serial number range where a particular part is used.

Indicated by:

“S/N XXXXX AND BELOW”

“S/N XXXX AND ABOVE”

“S/N XXXX TO S/N XXX”

Specific Model Number Use — Indicates that the part is used only with the specific model number or model number variant listed. It can also be used to show a part is NOT used on a specific model or model number variant.

Indicated by:

“XXXXX ONLY”

“NOT USED ON XXXX”

“Make/Obtain Locally” — Indicates that the part can be purchased at any hardware shop or made out of available items. Examples include battery cables, shims, and certain washers and nuts.

“Not Sold Separately” — Indicates that an item cannot be purchased as a separate item and is either part of an assembly/kit that can be purchased, or is not available for sale through Multiquip.

SUGGESTED SPARE PARTS

MVH308DZ PLATE COMPACTOR WITH 1B30 DIESEL ENGINE

1 to 3 units

Qty.	P/N	Description
4.....	939010260.....	SHOCK ABSORBER
4.....	939010010.....	SHOCK ABSORBER, STOPPER
2.....	070200433.....	V-BELT HDPF-5460
1.....	50384401.....	IGNITION SWITCH W/KEYS
3.....	50404900.....	KEY, IGNITION SWITCH
3.....	01542704.....	OIL, SUCTION FILTER
3.....	01635210.....	FUEL FILTER
3.....	50426000.....	ELEMENT, AIR CLEANER
1.....	01919702.....	FUEL FILTER, EXTENSION MTG.
1.....	01535302.....	CAP, FUEL TANK

NOTICE

Part numbers on this Suggested Spare Parts list may supersede/replace the part numbers shown in the following parts lists.

VIBRATING PLATE ASSY.

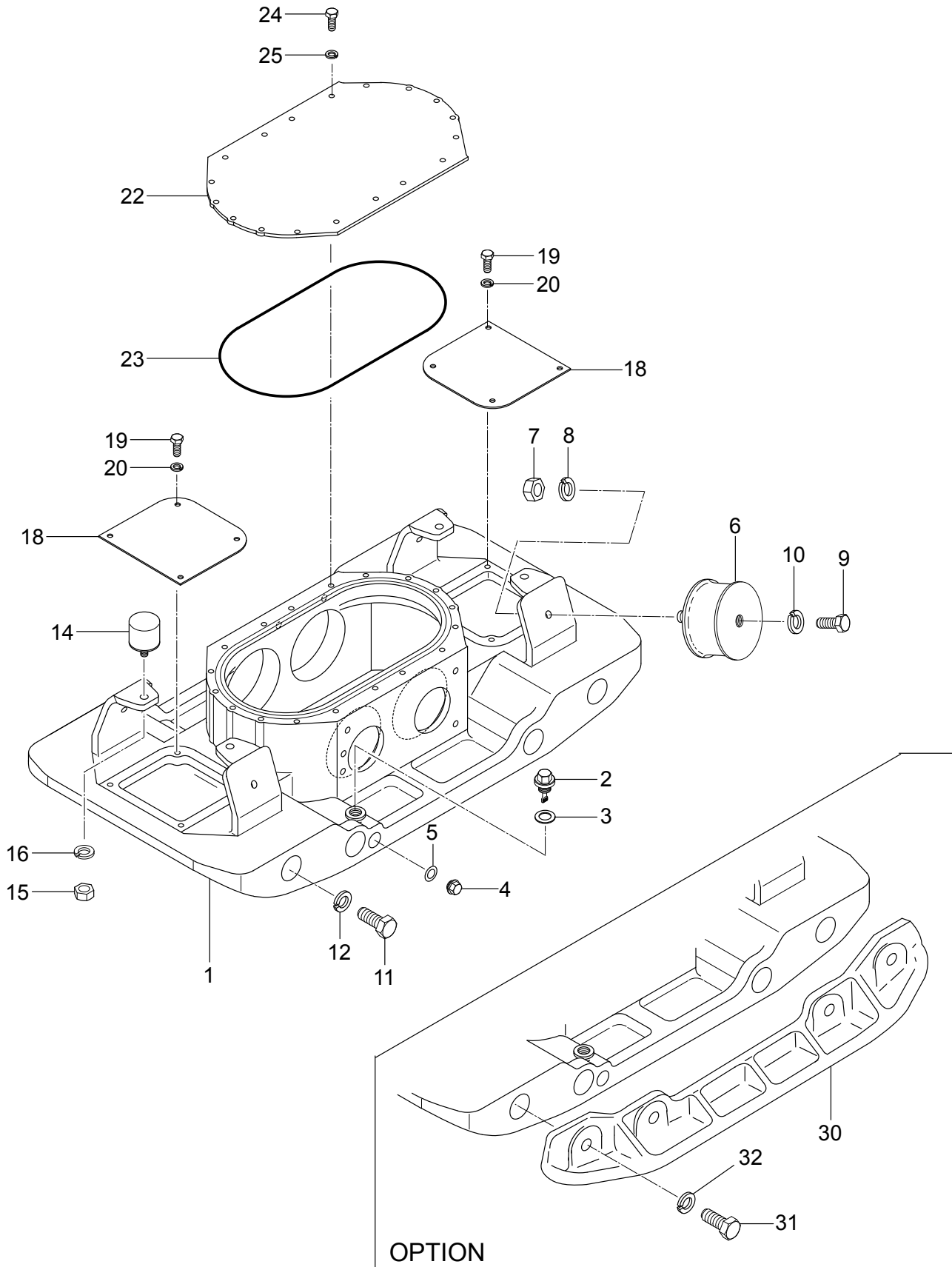

VIBRATING PLATE ASSY.

<u>NO.</u>	<u>PART NO.</u>	<u>PART NAME</u>	<u>QTY.</u>	<u>REMARKS</u>
1	467121090	VIBRATING PLATE	1	
2	465460670	OIL GAUGE	1	
3	953402930	COPPER PACKING	1	
4	953400270	PLUG	1	
5	953405260	PACKING	1	
6	939010260	SHOCK ABSORBER	4	
7	020316130	NUT	4	
8	030216400	WASHER, LOCK	4	
9	001221635	BOLT	4	
10	030216400	WASHER, LOCK	4	
11	001221830	BOLT	8	
12	58407	WASHER, LOCK	8.....	REPLACES P/N 030218460
14	939010010	SHOCK ABSORBER, STOPPER	4	
15	020310080	NUT	4	
16	030210250	WASHER, LOCK	4	
18	467351780	COVER, VIBRATING PLATE	2	
19	014208020	BOLT	8.....	REPLACES P/N 001220820
20	030208200	WASHER, LOCK	8	
22	467351790	COVER, VIBRATOR	1	
23	050103250	O-RING	1	
24	014208020	BOLT	18.....	REPLACES P/N 001220820
25	030208200	WASHER, LOCK	18	
30	467219050	EXTENSION PLATE	2	
31	012218050	BOLT	8.....	REPLACES P/N 001221850
32	58407	WASHER, LOCK	8.....	REPLACES P/N 030218460

VIBRATOR ASSY.

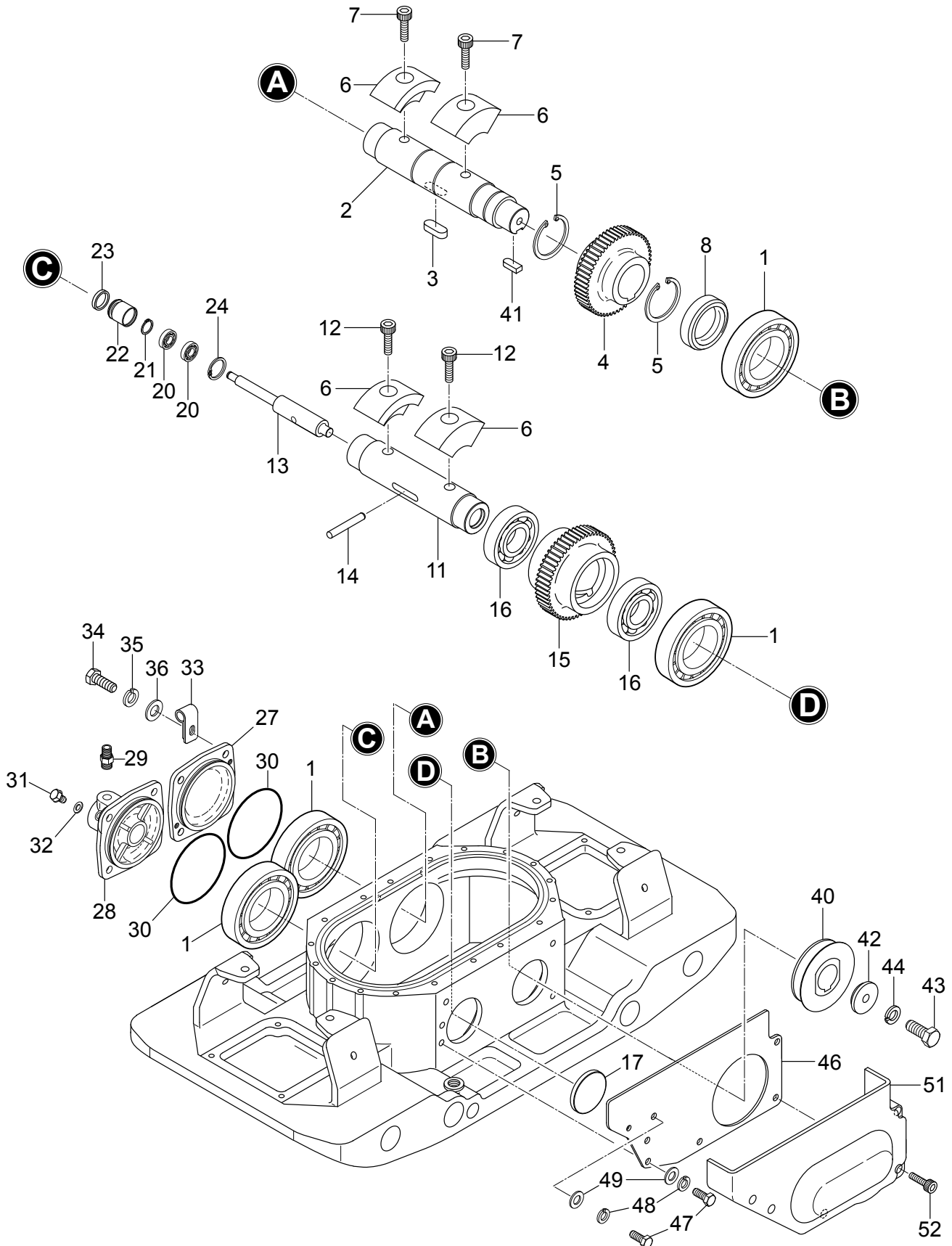

VIBRATOR ASSY.

<u>NO.</u>	<u>PART NO.</u>	<u>PART NAME</u>	<u>QTY.</u>	<u>REMARKS</u>
1	047920120	ROLLER BEARING	4	
2	457212410	ROTARY SHAFT, DRIVE	1	REPLACES P/N 456331060
3	951405370	KEY	1	
4	456327150	GEAR, DRIVE	1	
5	080200550	STOP RING	2	
6	464343700	ECCENTRIC ROTATOR	4	
7	009120301	SOCKET HEAD BOLT	2	
8	060105030	OIL SEAL	1	
11	456337670	ROTARY SHAFT, DRIVEN	1	
12	009120302	SOCKET HEAD BOLT	2	
13	456337380	PISTON ROD	1	
14	456010010	KNOCK PIN	1	
15	467351910	GEAR (DRIVEN)	1	
16	040006911	BEARING	2	
17	953010030	SEAL CAP	1	
20	042506000	BEARING	2	
21	0080000010	STOP RING	1	REPLACES P/N 080200100
22	455435051	PISTON	1	
23	455010070	PACKING	1	
24	080100260	STOP RING	1	
27	467352540	BEARING COVER	1	
28	467219070	CYLINDER (R)	1	
29	954010020	CONNECTOR PT	1	
30	050101050	O-RING	2	
31	001720812	FLANGE BOLT	1	
32	953404600	COPPER PACKING	1	
33	959408880	CLIP 15 (M10)	1	
34	0105091025	BOLT	8	REPLACES P/N 001221025
35	030210250	WASHER, LOCK	8	
36	031110160	WASHER, FLAT	8	
40	467351930	VIBRATING PULLEY	1	
41	951404970	KEY	1	
42	464457370	WASHER	1	
43	012012030	BOLT	1	REPLACES P/N 001221230
44	030212300	WASHER, LOCK	1	
46	467351920	GUIDE, BELT COVER	1	
47	014208020	BOLT	2	REPLACES P/N 001220820
48	030208200	WASHER, LOCK	2	
49	0401450080	WASHER, FLAT	2	REPLACES P/N 031108160
51	467218890	BELT COVER, LOWER	1	
52	001520852	SOCKET HEAD BOLT	5	

BASE AND ENGINE ASSY.

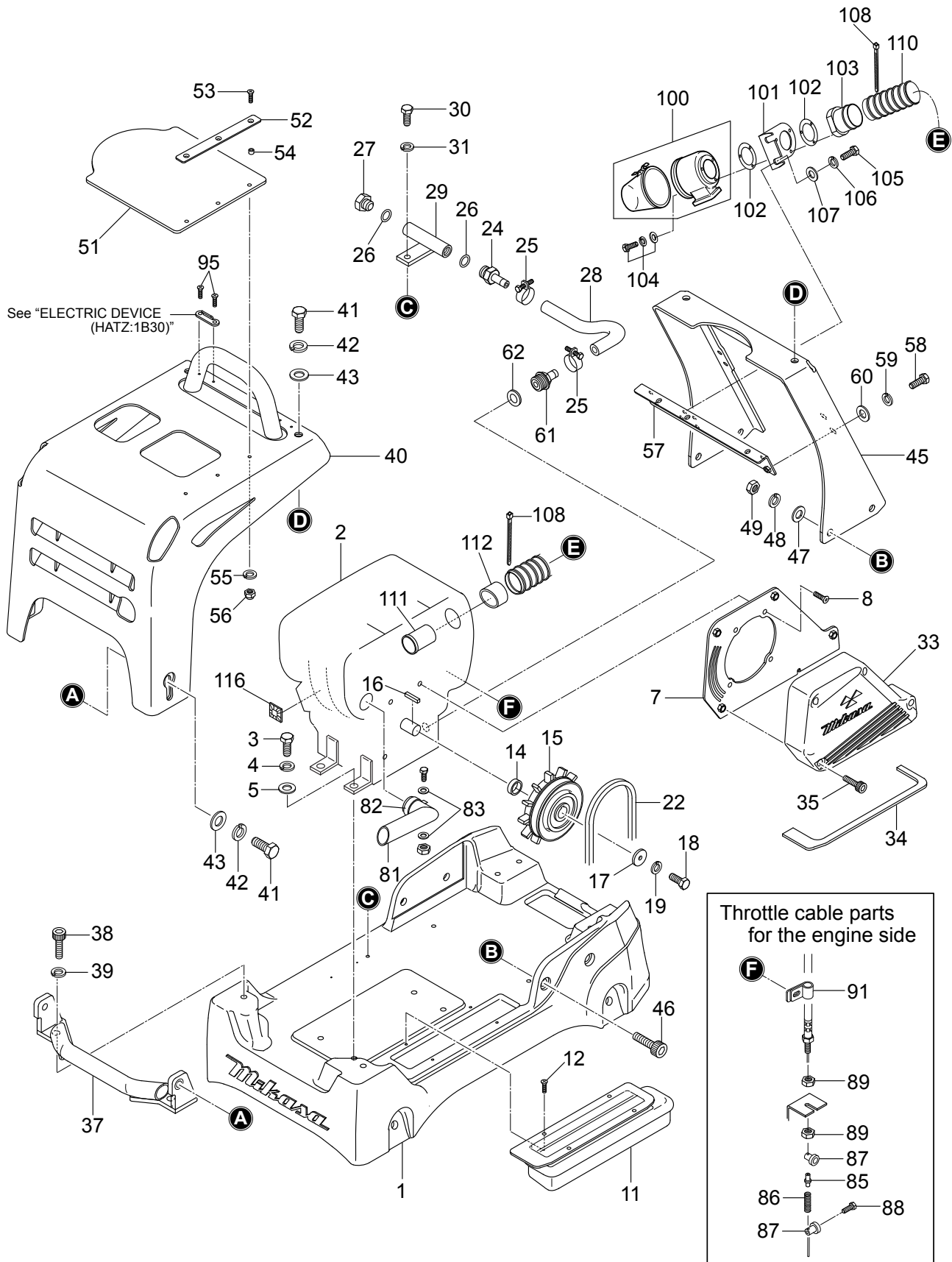

BASE AND ENGINE ASSY.

<u>NO.</u>	<u>PART NO.</u>	<u>PART NAME</u>	<u>QTY.</u>	<u>REMARKS</u>
1	467121150	BASE 1B30	1	
2	918401000	ENGINE ASSY. 1B30	1	
3	011208030	BOLT	4	REPLACES P/N 001220830
4	030208200	WASHER, LOCK	4	
5	040145008	WASHER, FLAT	4	REPLACES P/N 031108160
7	467351830	BELT COVER, IN	1	
8	009120416	SUNK HEAD BOLT	4	
11	467218860	DUST COVER	1	
12	092006010	FLAT HEAD SCREW	4	
14	952408810	SPACER	1	
15	456343340	CLUTCH ASSY.	1	
16	951400110	KEY	1	
17	952403450	WASHER	1	
18	01201003	BOLT	1	REPLACES P/N 001221030
19	030210250	WASHER, LOCK	1	
22	070200433	V-BELT, HDPF-5460	1	
24	954407310	UNION, DRAIN	1	
25	0091720000	HOSE CLAMP	2	
26	0211140020	GASKET	2	
27	0401140030	PLUG	1	
28	465459390	DRAIN HOSE	1	
29	464457380	DRAIN JOINT	1	
30	014208020	BOLT	1	REPLACES P/N 001220820
31	030208200	WASHER, LOCK	1	
33	467121100	BELT COVER (OUT)	1	
34	467351800	DUST SPONGE (OUT)	1	
35	001521053	SOCKET HEAD BOLT	4	
37	467351810	FRONT BUMPER	1	
38	001521435	SOCKET HEAD BOLT	2	
39	030214350	WASHER, LOCK	2	
40	467121110	FRONT COVER	1	
41	001221445	BOLT	4	
42	030214350	WASHER, LOCK	4	
43	031114260	WASHER, FLAT	4	
45	467218870	CENTER COVER	1	
46	001521435	SOCKET HEAD BOLT	4	
47	031114260	WASHER, FLAT	4	
48	030214350	WASHER, LOCK	4	
49	020314110	NUT	4	
51	467466750	RUBBER COVER, UPPER	1	

BASE AND ENGINE ASSY. (CONTINUED)

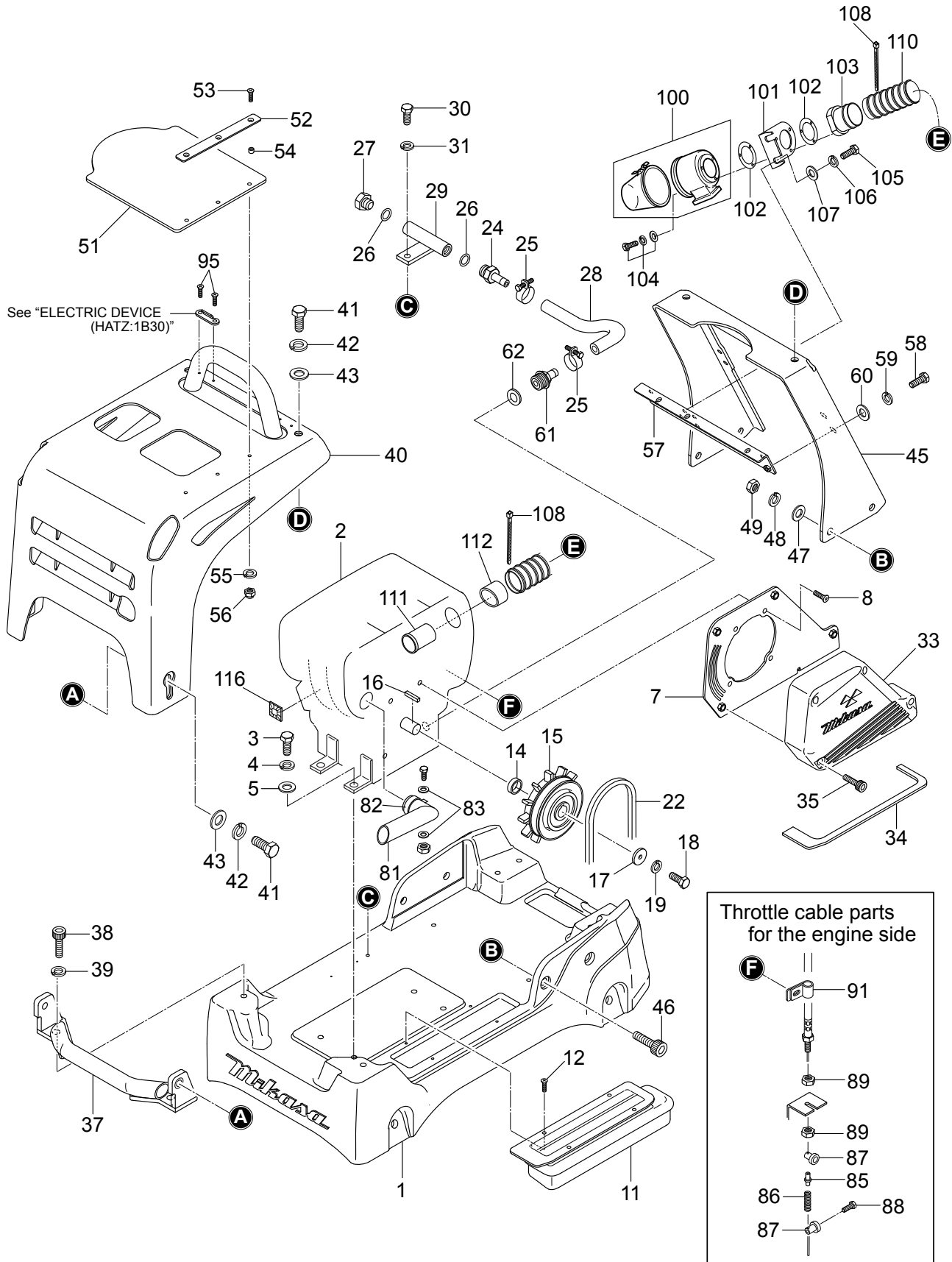

BASE AND ENGINE ASSY. (CONTINUED)

<u>NO.</u>	<u>PART NO.</u>	<u>PART NAME</u>	<u>QTY.</u>	<u>REMARKS</u>
52	467466760	STOPPER, COVER	1	
53	009120424	SOCKET HEAD BOLT	3	
54	617465130	COLLAR	3	
55	030206150	WASHER, LOCK	3	
56	022710607	NYLON NUT	3	
57	467351820	CLEANER STAY	1	
58	014208020	BOLT	4	REPLACES P/N 01220820
59	030208200	WASHER, LOCK	4	
60	040145008	WASHER, FLAT	4	REPLACES P/N 031108160
61	465459670	OIL DRAIN	1	
62	50001600	JOINT A	1	
81	467466780	EX. PIPE	1	
82	506397-00	PIPE CLIP	1	
83	040145008	WASHER, FLAT	2	REPLACES P/N 031108160
85	05165000	GUIDE BUSH	1	
86	50484600	PRESSURE SPRING	1	
87	01647300	CABLE CLAMP	2	
88	50025000	HEX SCREW	1	
89	020106050	NUT.....	2	REPLACES P/N 020306050
91	2067550101	CLAMP COMPL.	1	
95	009120420	SOCKET HEAD BOLT	4	
100	466218080	CLEANER, CYCLONE	1	
101	467351890	CYCLONE STAY	1	
102	466462850	GASKET, AIR INTAKE	2	
103	467466840	JOINT, C-CLEANER	1	
104	009110057	SOCKET HEAD BOLT	3	
105	014208020	BOLT	2	REPLACES P/N 001220820
106	030208200	WASHER, LOCK	2	
107	040145008	WASHER, FLAT	2	REPLACES P/N 031108160
108	506010060	CLAMP TC-350	2	
110	465348910	DUCT HOSE	1	
111	467466850	INTAKE PIPE	1	
112	467466860	GROMMET, CLEANER	1	
116	955407970	WIRING, FIXED BASE	1	

ELECTRIC DEVICE ASSY.

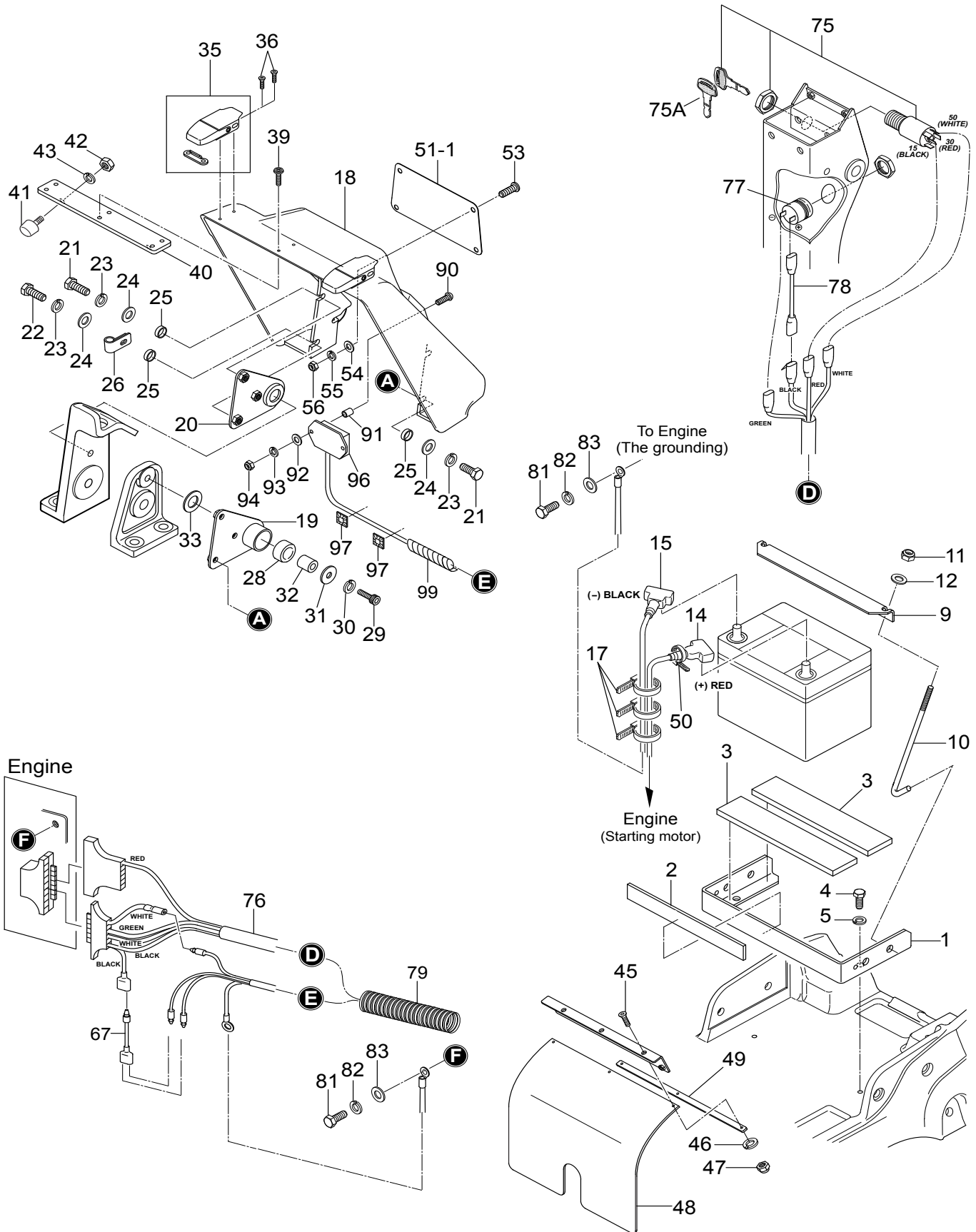

ELECTRIC DEVICE ASSY.

<u>NO.</u>	<u>PART NO.</u>	<u>PART NAME</u>	<u>QTY.</u>	<u>REMARKS</u>
1	467218920	BATTERY HOLDER	1	
2	456447590	RUBBER PLATE (E)	1	
3	456447600	RUBBER PLATE	2	
4	012210020	BOLT.....	2.....	REPLACES P/N 001221020
5	030210250	WASHER, LOCK	2	
9	464343740	HOLDER, BATTERY	1	
10	469467170	BOLT, BATTERY	2	
11	022710809	NYLON NUT	2	
12	0401450080	WASHER, FLAT.....	2.....	REPLACES P/N 031108160
14	955301030	BATTERY CABLE (+) 1050L	1	
15	955301040	BATTERY CABLE (-) 450L	1	
17	506010070	CLAMP	5	
18	467121190	REAR COVER	1	
19	467352020	BRACKET, REAR COVER (L)	1	
20	467352030	BRACKET, REAR COVER (R)	1	
21	014208020	BOLT.....	5.....	REPLACES P/N 001220820
22	011208025	BOLT.....	1.....	REPLACES P/N 001220825
23	030208200	WASHER, LOCK	6	
24	0401450080	WASHER, FLAT.....	6.....	REPLACES P/N 031108160
25	952408780	COLLAR	6	
26	959408920	CLIP 8 (M8)	1	
28	416459340	RUBBER, VAS HANDLE	2	
29	014210040	SOCKET HEAD BOLT.....	2.....	REPLACES P/N 001521040
30	030210250	WASHER, LOCK	2	
31	952408740	WASHER	2	
32	952408790	COLLAR	2	
33	467467250	RUBBER WASHER	2	
35	467467090	CATCH CLIP	2	
36	009120421	SOCKET HEAD BOLT	4	
39	009110073	SOCKET HEAD SCREW	2	
40	467352060	BRACKET, STOPPER	1	
41	939010360	STOPPER RUBBER	2	
42	020108060	NUT.....	2.....	REPLACES P/N 020308060
43	030208200	WASHER, LOCK	2	
45	009120422	SOCKET HEAD BOLT	3	
46	030205130	WASHER, LOCK	3	
47	022710506	NYLON NUT	3	
48	467466930	RUBBER PLATE, BATTERY	1	
49	467466920	STOPPER, RUB-PLATE	1	
50	454010020	CLAMP	9	
51-1	467352050	PANEL, REAR COVER	1	

ELECTRIC DEVICE ASSY. CONTINUED

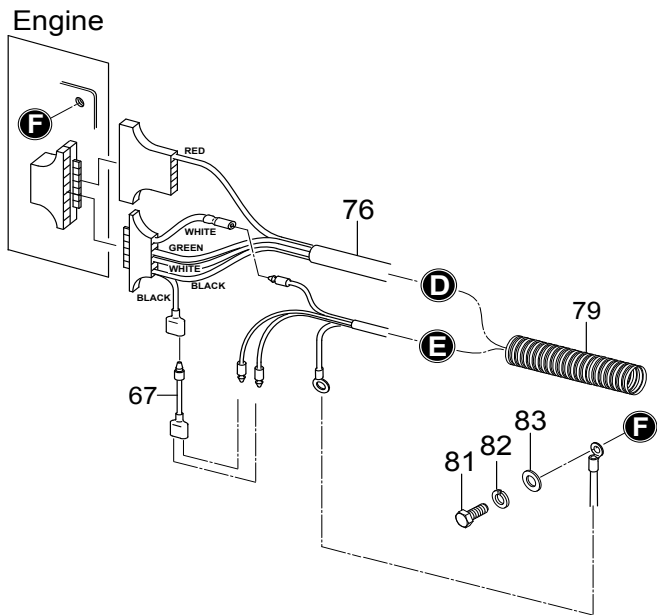
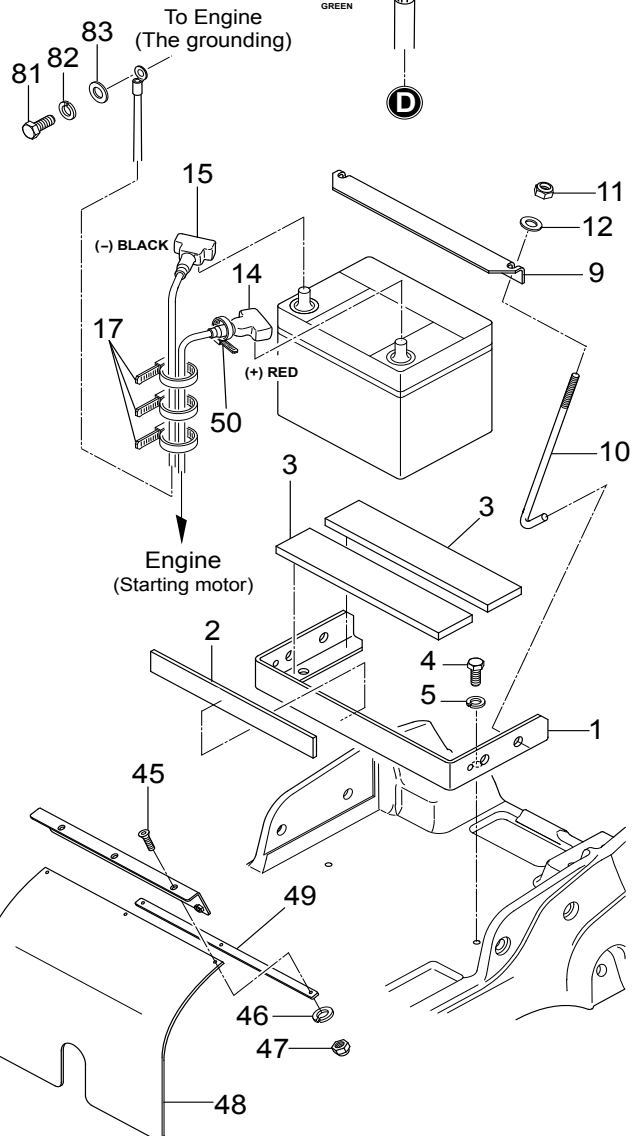
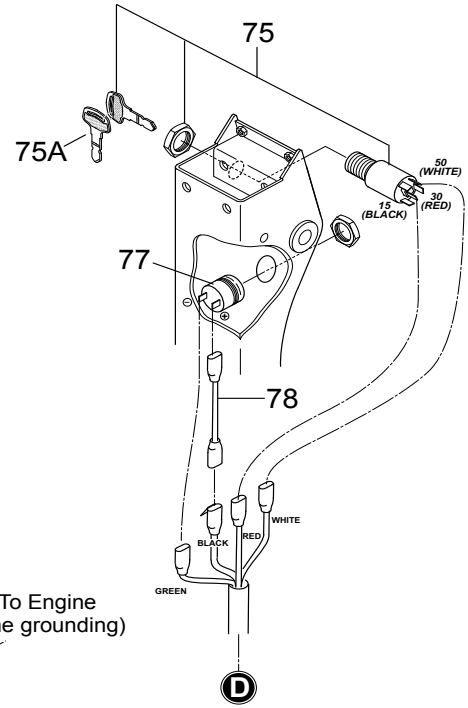
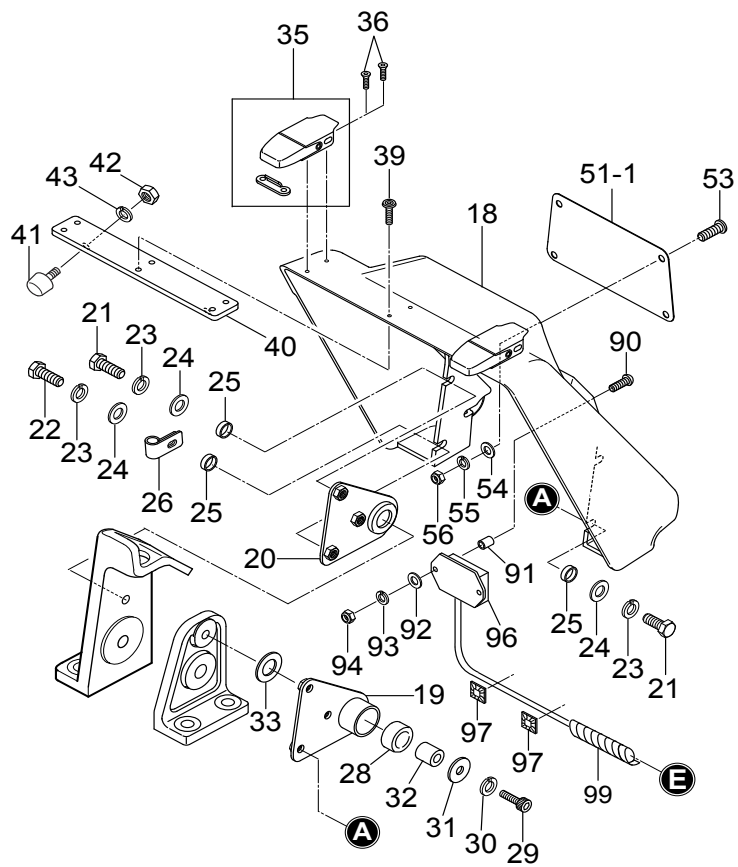

ELECTRIC DEVICE ASSY. CONTINUED

<u>NO.</u>	<u>PART NO.</u>	<u>PART NAME</u>	<u>QTY.</u>	<u>REMARKS</u>
53	009110062	SOCKET HEAD SCREW	4	
54	952404470	WASHER, FLAT	4	REPLACES P/N 031106100
55	030206150	WASHER, LOCK	4	
56	022710607	NYLON NUT	4	
67	515450380	WIRE HARNESS	1	
75	50384401	IGNITION SWITCH W/ KEY	1	INCLUDES ITEM W/\$
75A\$	50404900	KEY, IGNITION SWITCH	1	
76	467352070	WIRE HARNESS	1	
77	50465100	BUZZER	1	
78	465459680	RELAY CABLE/BUZZER	1	
79	959026022	CORRUGATE TUBE	1	
81	001220612	BOLT	2	
82	030206150	WASHER, LOCK	2	
83	952404470	WASHER, FLAT	2	REPLACES P/N 031106100
90	009110072	PAN HEAD SCREW	2	
91	952407930	COLLAR	2	
92	58151	WASHER, FLAT	2	REPLACES P/N 031105080
93	030205130	WASHER, LOCK	2	
94	022710506	NYLON NUT	2	
96	955301020	TACHOMETER/HOUR METER	1	
97	955407970	WIRING, FIXED BASE	2	
99	959021813	SPIRAL TUBE	1	

CONTROL ASSY.

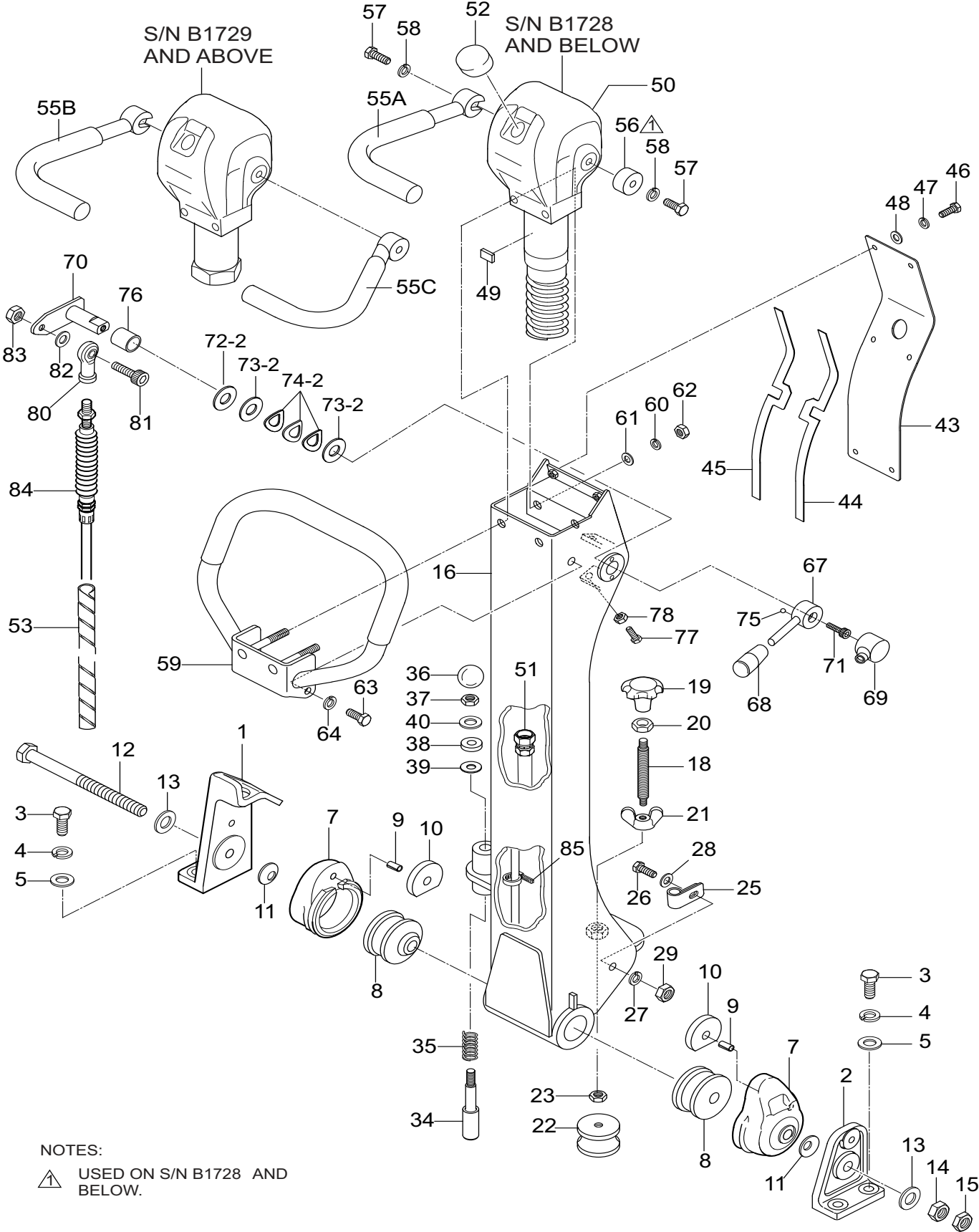

NOTES:
 ▲ USED ON S/N B1728 AND BELOW.

CONTROL ASSY.

<u>NO.</u>	<u>PART NO.</u>	<u>PART NAME</u>	<u>QTY.</u>	<u>REMARKS</u>
1	467351950	HANDLE BRACKET (R)	1	
2	467351960	HANDLE BRACKET (L)	1	
3	012212035	BOLT	4	REPLACES P/N 001221235
4	030212300	WASHER, LOCK	4	
5	031112230	WASHER, FLAT	4	
7	456336400	RUBBER COUPLING	2	
8	456449940	SHOCK ABSORBER	2	
9	025306016	SPRING PIN	2	REPLACES P/N 025406016
10	456449930	RUBBER PLATE	2	
11	032124400	CONICAL WASHER, LOCK	2	
12	001221681	BOLT	1	
13	0401450160	WASHER, FLAT	2	REPLACES P/N 031116260
14	020316130	NUT	1	
15	020416100	NUT	1	
16	467121170	COLUMN, HANDLE BAR	1	
18	455434950	SPINDLE	1	
19	455010030	KNOB	1	
20	020412070	NUT	1	
21	022411635	WING NUT	1	
22	939010060	SHOCK ABSORBER	1	
23	020310080	NUT	1	REPLACES P/N 020410060
25	959408930	CLIP	1	
26	011206020	BOLT	1	REPLACES P/N 001220620
27	030206150	WASHER, LOCK	1	
28	952404470	WASHER, FLAT	1	REPLACES P/N 031106100
29	020106050	NUT	1	REPLACES P/N 020306050
34	501402870	HANDLE STOPPER	1	
35	501402880	SPRING/HANDLE	1	
36	959403460	BALL GRIP	1	
37	020310080	NUT	1	REPLACES P/N 020410060
38	456449980	RUBBER PACKING	1	
39	953405260	PACKING 1/4	1	
40	031110160	WASHER, FLAT	1	
43	467351970	HANDLE COVER	1	
44	467467340	PACKING (L), HANDLE	1	
45	467467350	PACKING (R), HANDLE	1	
46	0105050616	BOLT	6	REPLACES P/N 001220615
47	030206150	WASHER, LOCK	6	
48	952404470	WASHER, FLAT	6	REPLACES P/N 031106100
49	464457930	RUBBER PIECE	1	
50	467219140	HYDRAULIC PUMP	1	

CONTROL ASSY. (CONTINUED)

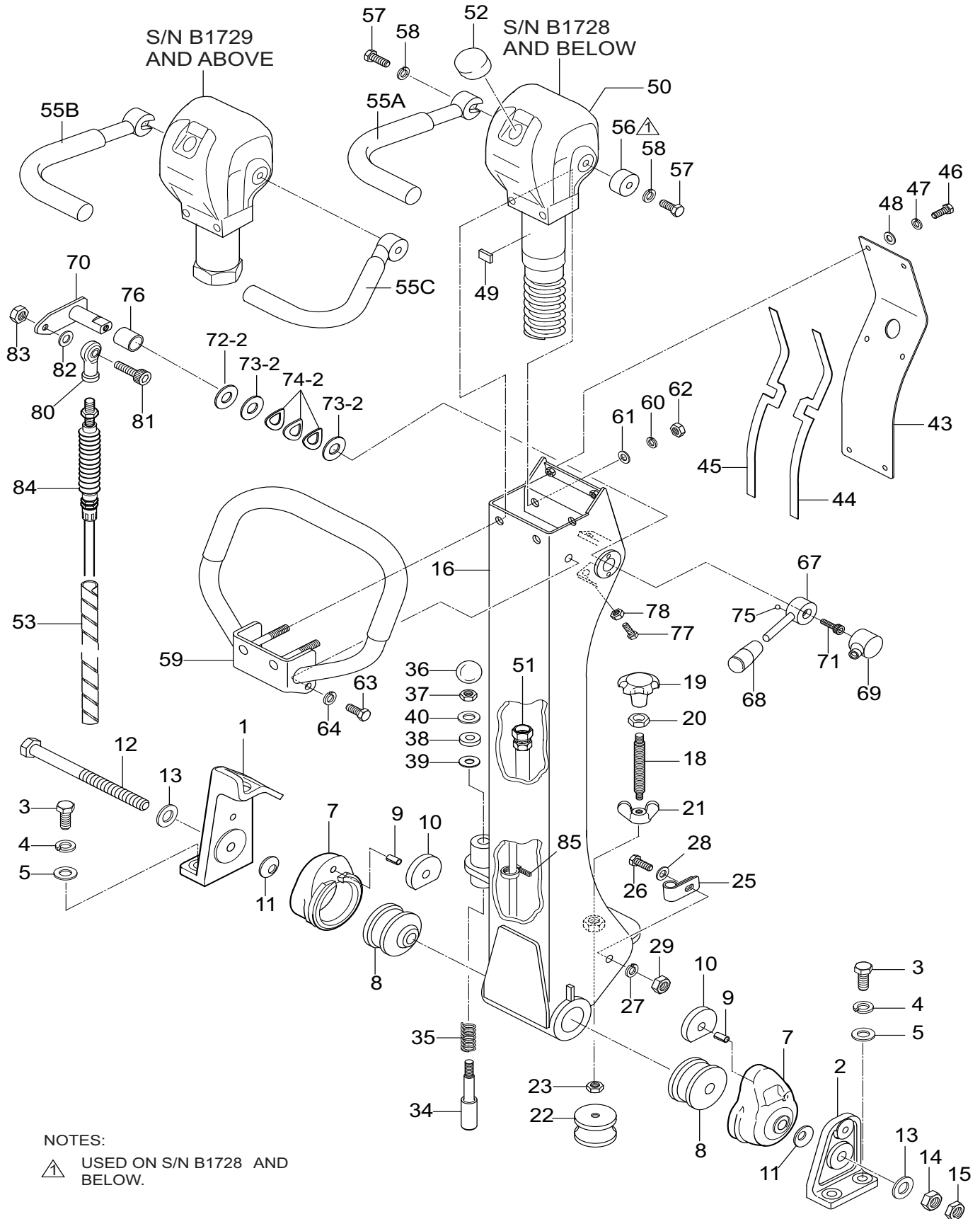

CONTROL ASSY. (CONTINUED)

<u>NO.</u>	<u>PART NO.</u>	<u>PART NAME</u>	<u>QTY.</u>	<u>REMARKS</u>
51	954003110	OIL HOSE	1	
52	458451630	BREATHER CAP	1	
53	959021813	SPIRAL TUBE	1	
55A	464216630	TRAVEL LEVER, RIGHT	1.....	S/N B1728 AND BELOW
55B	464216820	TRAVEL LEVER, RIGHT	1.....	S/N B1729 AND ABOVE
55C	464216830	TRAVEL LEVER, LEFT.....	1.....	S/N B1729 AND ABOVE
56	464457400	HANDLE BOSS	1.....	S/N B1728 AND BELOW
57	012010030	BOLT	2.....	REPLACES P/N 001221030
58	030210250	WASHER, LOCK	2	
59	467218900	HANDLE W/ RUBBER GRIP	1	
60	030210250	WASHER, LOCK	2	
61	031110160	WASHER, FLAT	2	
62	020310080	NUT	2	
63	0105091025	BOLT	2.....	REPLACES P/N 001221025
64	030210250	WASHER, LOCK	2	
67	467466960	LEVER, THROTTLE	1	
68	959403840	BAR GRIP	1	
69	464457420	COVER, THROTTLE LEVER	1	
70	464457350	ARM, THROTTLE	1	
71	014208020	SOCKET HEAD BOLT	1.....	REPLACES P/N 001520820
72-1	952408950	WASHER	1	
73-1	458450660	WASHER	1	
74-1	033910080	CONICAL WASHER, LOCK	3	
75	464457440	STEEL BALL	1	
76	464010010	DRY BUSHING	1	
77	011606025	BOLT	2.....	REPLACES P/N 001220625
78	020106050	NUT	2.....	REPLACES P/N 020306050
80	464010020	ROD END	1	
81	001520520	SOCKET HEAD BOLT	1	
82	58151	WASHER, FLAT	1.....	REPLACES P/N 031105080
83	020305040	NUT	1	
84	956100069	THROTTLE WIRE	1	
85	454010020	CLAMP	1	

NAMEPLATE AND DECALS ASSY.

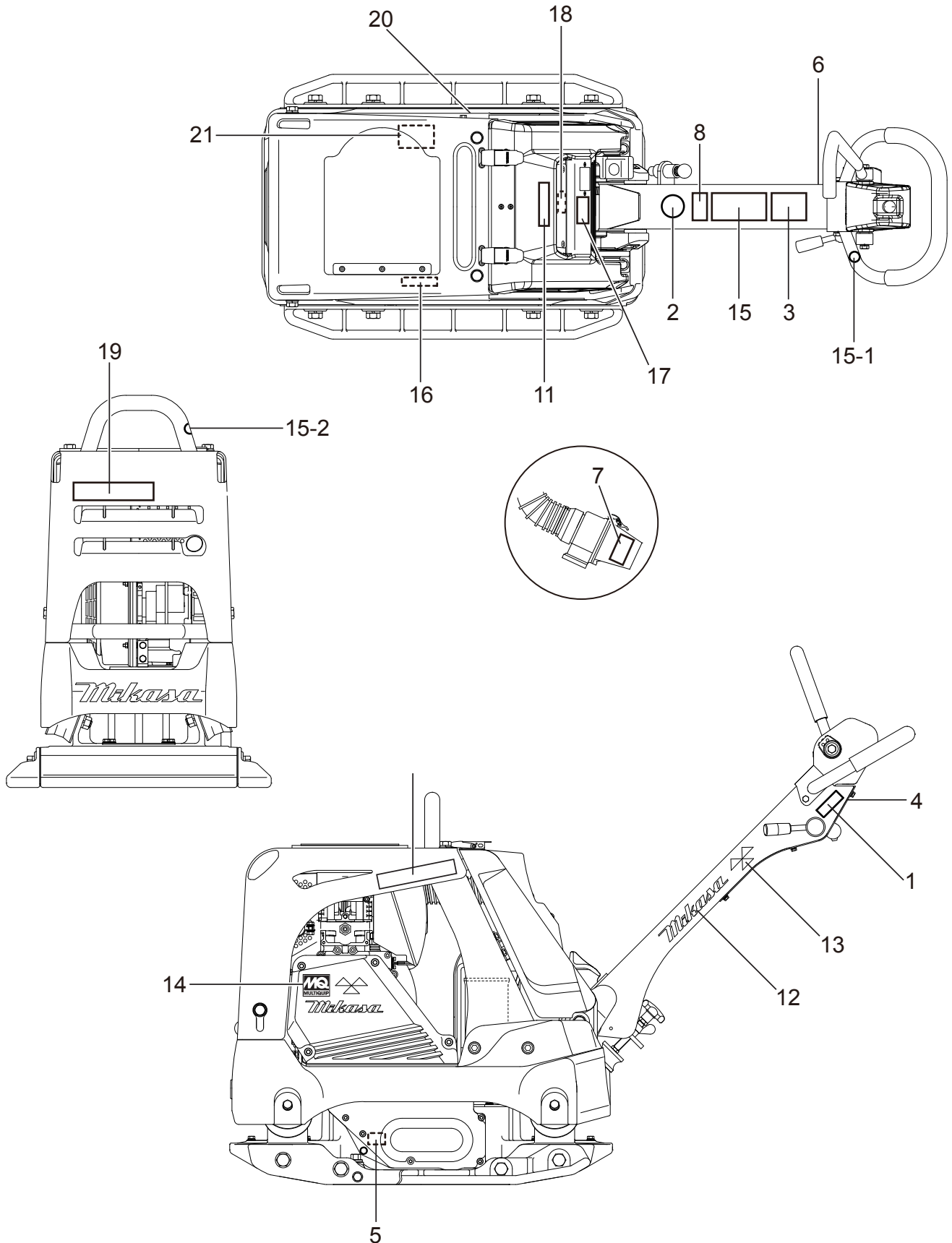

NAMEPLATE AND DECALS ASSY.

<u>NO.</u>	<u>PART NO.</u>	<u>PART NAME</u>	<u>QTY.</u>	<u>REMARKS</u>
1	920204580	DECAL, FULL THROTTLE	1	
2	920203330	DECAL, EAR PROTECTION LABEL	1	
3	920211060	DECAL, CAUTION (LEVER)	1	
4	920211090	DECAL, SHELL TELLUS OIL 32	1	
5	920201950	DECAL, OIL SAE 10W-30	1	
6	920106760	DECAL, STOP-RUN-START	1	
7	920214200	DECAL, CAUTION CYCLONE	1	
8	920214100	DECAL, E/G FIRE WARNING	1	
11	920216610	DECAL, CAUTION (FOR WASHING)	1	
12	920217130	DECAL, MIKASA MARK (W) 200L	2	
13	920217110	DECAL, MIKASA MARK 35X70	2	
14	920201580	DECAL, MQ MARK 71X55	1	
15	920218390	DECAL, CAUTION	1	
15-1	920214730	DECAL, DO NOT LIFT	1	
15-2	920214740	DECAL, LIFTING POSITION	1	
16	920217670	DECAL, V-BELT HDPF-5430	1	
17	920218140	DECAL, E/G RPM 3400	1	
18	920217870	DECAL, MODEL MVH-308	1	
19	920217730	DECAL, MODEL MVH-308 R	2	
20	920217740	DECAL, MODEL MVH-308 L	1	
21		PLATE, SERIAL NO.1.....	1	CONTACT MQ PARTS DEPT.

HATZ 1B30 ENGINE — SPARE PARTS KIT ASSY.

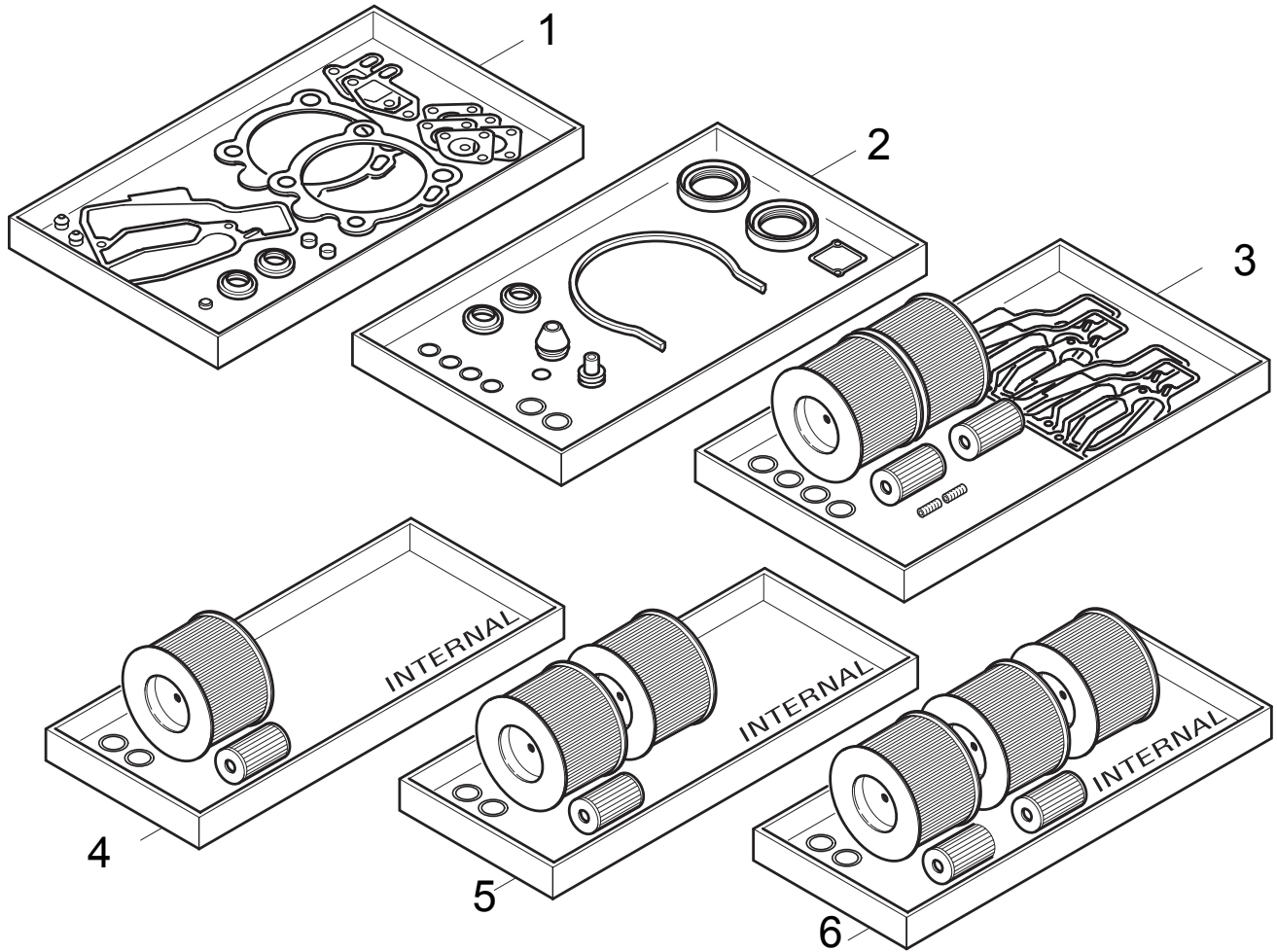

HATZ 1B30 ENGINE — SPARE PARTS KIT ASSY.

<u>NO.</u>	<u>PART NO.</u>	<u>PART NAME</u>	<u>QTY.</u>	<u>REMARKS</u>
1	01582211	GASKET SET, CYLINDER HEAD	1	
2	01582305	GASKET SET, CRANKCASE	1	
3	01582420	MAINTENANCE KIT	1	
4	02265400	FILTER KIT 1B30/INT. LIGHT	1	
5	02267900	FILTER KIT 1B30/INT./MED.	1	
6	02269000	FILTER KIT 1B30/INT. IHEA.	1	

HATZ 1B30 ENGINE — ACCESSORIES ASSY.

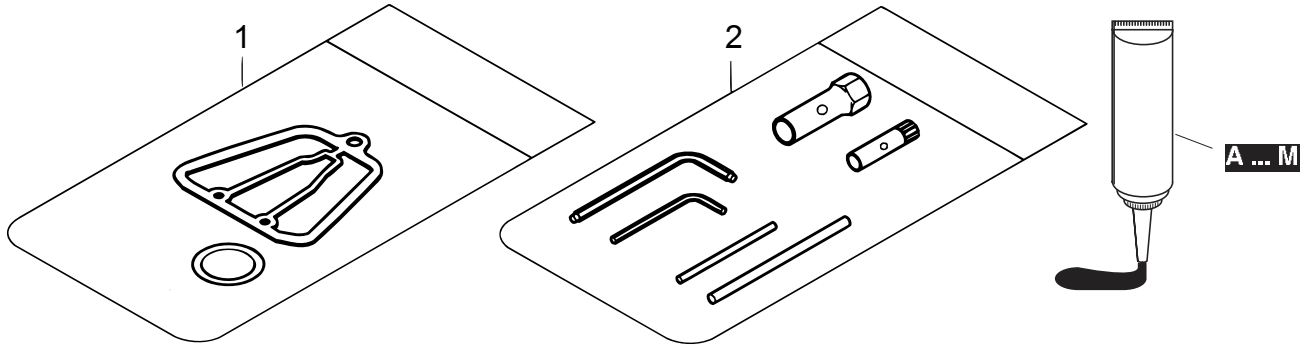

HATZ
DIESEL

WARTUNG - MAINTENANCE
ENTRETIEN - MANTENIMIENTO
MANUTENZIONE

8-15 250

STUNDEN - HOURS - HEURES
HORAS - ORE

500

BEI BEDARF
IF NECESSARY
SI NECESSAIRE
EN CASO DE
NECESSIDAD
SE NECESARIO

IN
0.1 mm
0.004 "

max OIL

3

1B..

4

COMPR.

1

2

START

3

051 300 00

- (A)
LOCTITE ACTIVATOR N
- (B)
LOCTITE 574
- (C)
LOCTITE 601
- (D)
LOCTITE 221
- (E)
LOCTITE 648
- (F)
TECHNICAL ADHESIVE 8058
- (FA)
TECHNICAL CLEANER
- (G)
LOCTITE 407
- (H)
TEROSON TEROSTAT 63
- (J)
HIGH TEMP. PASTE
- (K)
HIGHT TEMP FETT 400G
- (L)
SILICON SEALER
- (M)
GRINDING PASTE 80 ML

HATZ 1B30 ENGINE — ACCESSORIES ASSY.

<u>NO.</u>	<u>PART NO.</u>	<u>PART NAME</u>	<u>QTY.</u>	<u>REMARKS</u>
A	50223001	LOCTITE ACTIVATOR N, 500 ML	1	
B	50223101	LOCTITE 574, 50 ML	1	
C	50223200	LOCTITE 601, 50 ML	1	
D	70018918	LOCTITE 243, 50 ML	1	
E	50223400	LOCTITE 648, 10 ML	1	
F	50223800	TECHNICAL ADHESIVE 8058, 750 GRAM	1	
FA	50223900	TECHNICAL CLEANER, 750 GRAM	1	
G	50256501	LOCTITE IS 407, 20 GRAM	1	
H	70018944	TEROSON TEROSTAT 63, 310 ML	1	
J	50283004	HIGH TEMPERATURE PASTE, 100 ML	1	
K	50342601	HIGH TEMP. FETT 400 GRAM	1	
L	50256600	SILICON SEALER, 100 GRAM	1	
M	50485100	GRINDING PASTE 80ML/GRAM	1	
1	01578710	ACCESSORIES KIT	1	
2	01330901	TOOLS	1	
3	05110406	STICKER LABEL	1	
4	05130002	STICKER LABEL "START"	1	

HATZ 1B30 ENGINE — CRANKCASE ASSY.

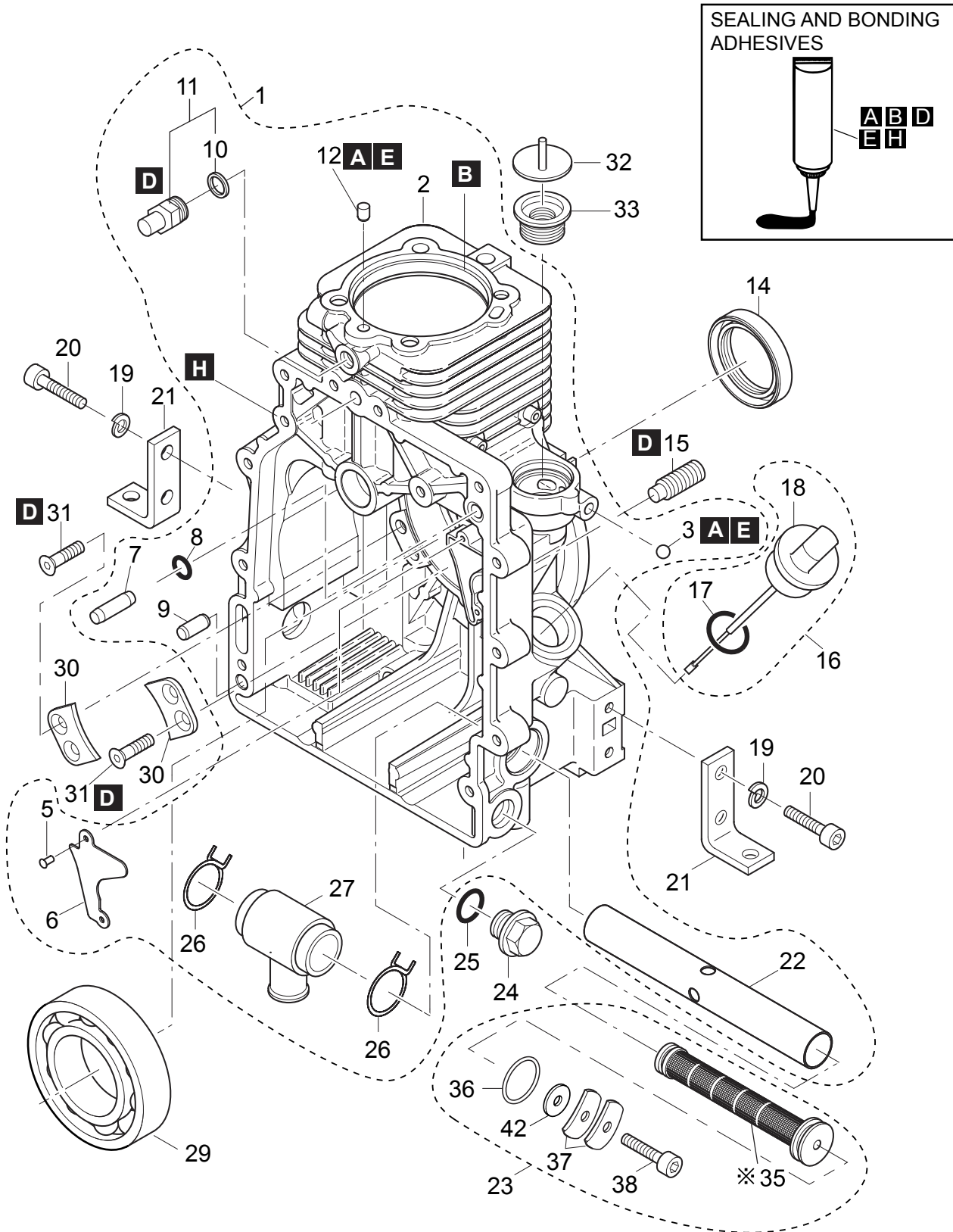

※ NOT SOLD SEPARATELY

HATZ 1B30 ENGINE — CRANKCASE ASSY.

<u>NO.</u>	<u>PART NO.</u>	<u>PART NAME</u>	<u>QTY.</u>	<u>REMARKS</u>
A	50223001	LOCTITE ACTIVATOR N, 500 ML	1	
B	50223101	LOCTITE 574, 50 ML	1	
D	70018918	LOCTITE 243, 50 ML	1	
E	50223400	LOCTITE 648	1	
H	70018944	TEROSON TEROSTAT 63	1	
1	01582720	CRANKCASE ASSY.	1	INCLUDES ITEMS W/\$
2\$		CRANKCASE.....	1	NOT SOLD SEPARATELY
3\$		PLUG	1	NOT SOLD SEPARATELY
5\$	40002600	BLIND RIVET	1	
6\$	01333111	COVER SHEET	1	
7\$	50502801	CYLINDER PIN	1	
8\$	50440300	O-RING	1	
9\$	50249102	Z CYLINDER PIN	1	
10\$	50062400	JOINT A	1	
11\$	50469101	OIL PRESSURE SWITCH	1	
12\$		PLUG	1	NOT SOLD SEPARATELY
14	50449800	OIL SEAL	1	
15	04198700	GRUB SCREW CARB/EPA	1	
16	01316000	DIPSTICK ASSY.	1	INCLUDES ITEMS W/@
17@	04125000	SEALING RING, DIPSTICK	1	
18@		DIPSTICK	1	NOT SOLD SEPARATELY
19	50208500	WASHER, LOCK	1	
20	04121900	ALLEN SCREW	1	
21	04099302	ENGINE BRACKET	1	
22\$	04105710	TUBE F. OIL FILTER	1	
23	01542704	OIL SUCTION FILTER ASSY.....	1	INCLUDES ITEMS W/#
24	50373100	DRAIN PLG. MAGNT. M22	1	
25	50001600	GASKET	1	
26\$	05036900	HOSE CLIP	1	
27\$	04163000	T-PIECE	1	
29	50449700	GROOVE BALLBEARING	1	
30	04094400	PLATE	1	
31	50564300	COUNTERSUNK SCREW	1	
32	01555800	COVER	1	
33	03568701	OIL SUPPLEMENT PLUG	1	
35#		OIL SUCTION FILTER.....	1	NOT SOLD SEPARATELY
36#	50475901	O-RING	1	
37#	05148200	PLATE SPRING	1	
38#	50170700	ALLEN SCREW	1	
42#	04042000	WASHER	1	

HATZ 1B30 ENGINE — CRANKSHAFT ASSY.

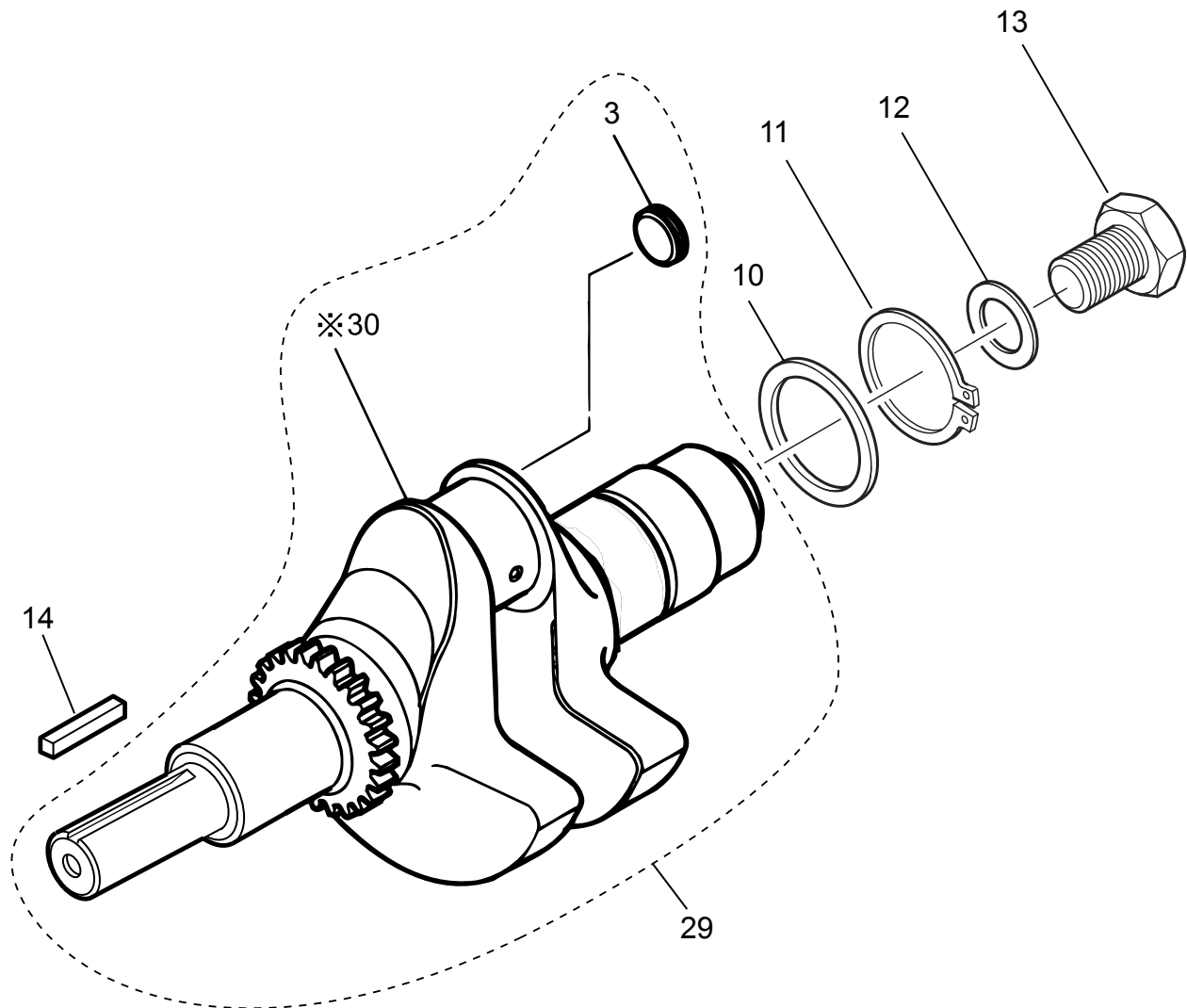

※ NOT SOLD SEPARATELY

HATZ 1B30 ENGINE — CRANKSHAFT ASSY.

<u>NO.</u>	<u>PART NO.</u>	<u>PART NAME</u>	<u>QTY.</u>	<u>REMARKS</u>
3\$	04287600	COVER 12	1	
10	40065600	SUPPORTING DISC SS	1	
11	50021600	CIRCLIP	1	
12	04114201	DISC 18	1	
13	50443600	HEXAGON SCREW	1	
14	952406810	KEY 7X7X35	1	
29	01856000	CRANKSHAFT ASSY.....	1.....	INCLUDES ITEMS W/\$
30\$		CRANKSHAFT.....	1.....	NOT SOLD SEPARATELY

HATZ 1B30 ENGINE — CAMSHAFT ASSY.

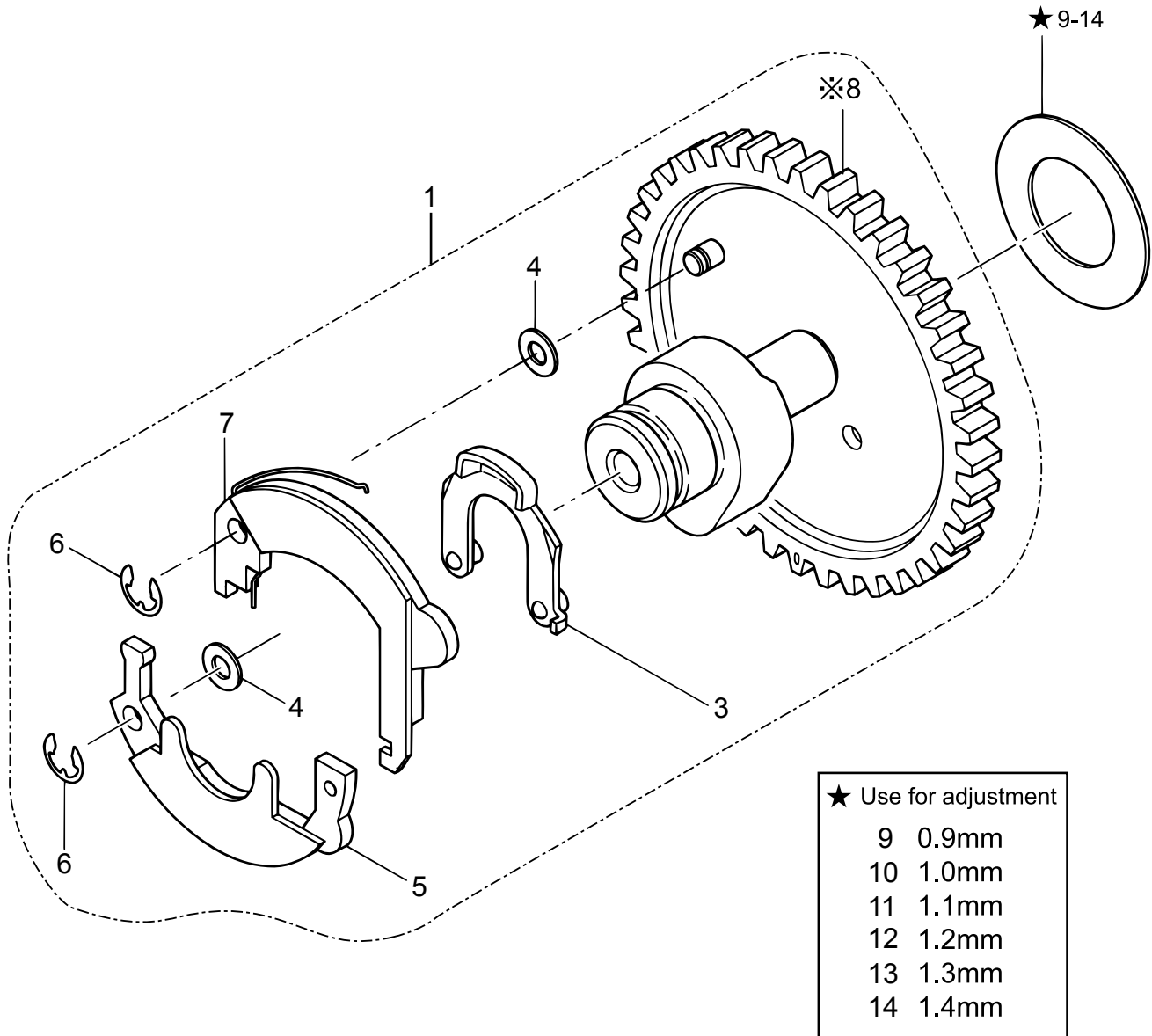

※ NOT SOLD SEPARATELY

HATZ 1B30 ENGINE — CAMSHAFT ASSY.

<u>NO.</u>	<u>PART NO.</u>	<u>PART NAME</u>	<u>QTY.</u>	<u>REMARKS</u>
1	01503523	CAMSHAFT ASSY.	1.....	INCLUDES ITEMS W/\$
3\$	01326401	CAM LEVER	1	
4\$	50123200	SHIM	2	
5\$	01326600	FLYWEIGHT	1	
6\$	50255300	LOCKING WASHER	2	
7\$	01326501	FLYWEIGHT HAND-START	1	
8\$		CAMSHAFT	1.....	NOT SOLD SEPARATELY
9	04121700	SHIM 23X38X0.9	1.....	SELECT 0-1
10	04112100	SHIM 23X38X1.0	1.....	SELECT 0-1
11	04112200	SHIM 23X38X1.1	1.....	SELECT 0-1
12	04112300	SHIM 23X38X1.2	1.....	SELECT 0-1
13	04125100	SHIM 23X38X1.3	1.....	SELECT 0-1
14	04125200	SHIM 23X38X1.4	1.....	SELECT 0-1

HATZ 1B30 ENGINE — PISTON, CONROD, CYLINDER ASSY.

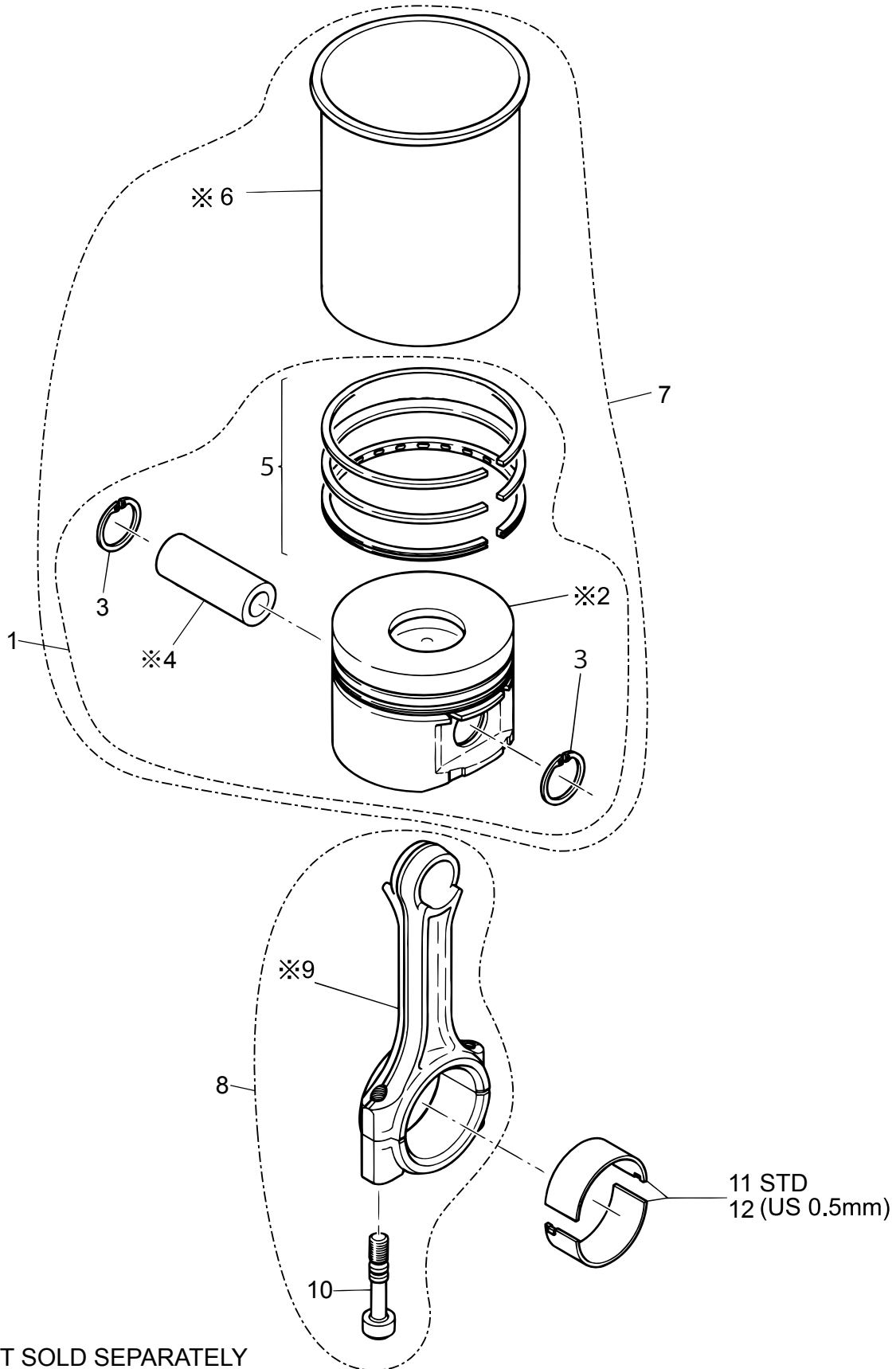

HATZ 1B30 ENGINE — PISTON, CONROD, CYLINDER ASSY.

<u>NO.</u>	<u>PART NO.</u>	<u>PART NAME</u>	<u>QTY.</u>	<u>REMARKS</u>
1	01390621	PISTON AND RINGS ASSY.	1.....	INCLUDES ITEMS W/\$
2\$@		PISTON.....	1.....	NOT SOLD SEPARATELY
3\$@	50464000	CIRCLIP	2	
4\$@		PIN, PISTON.....	1.....	NOT SOLD SEPARATELY
5\$@	01390700	PISTON RING SET	1	
6@		CYLINDER.....	1.....	NOT SOLD SEPARATELY
7	01582620	CYLINDER ASSY. W/PISTON & RINGS	1.....	INCLUDES ITEMS W/@
8	01329201	CONROD ASSY.	1.....	INCLUDES ITEMS W/#
9#		CONROD	1.....	NOT SOLD SEPARATELY
10#	04113100	CONROD SCREW	2	
11	01582100	BIG END BEARING, STANDARD	1	
12	01582000	BIG END BEARING US 0.5MM	1	

HATZ 1B30 ENGINE — CYLINDER HEAD ASSY.

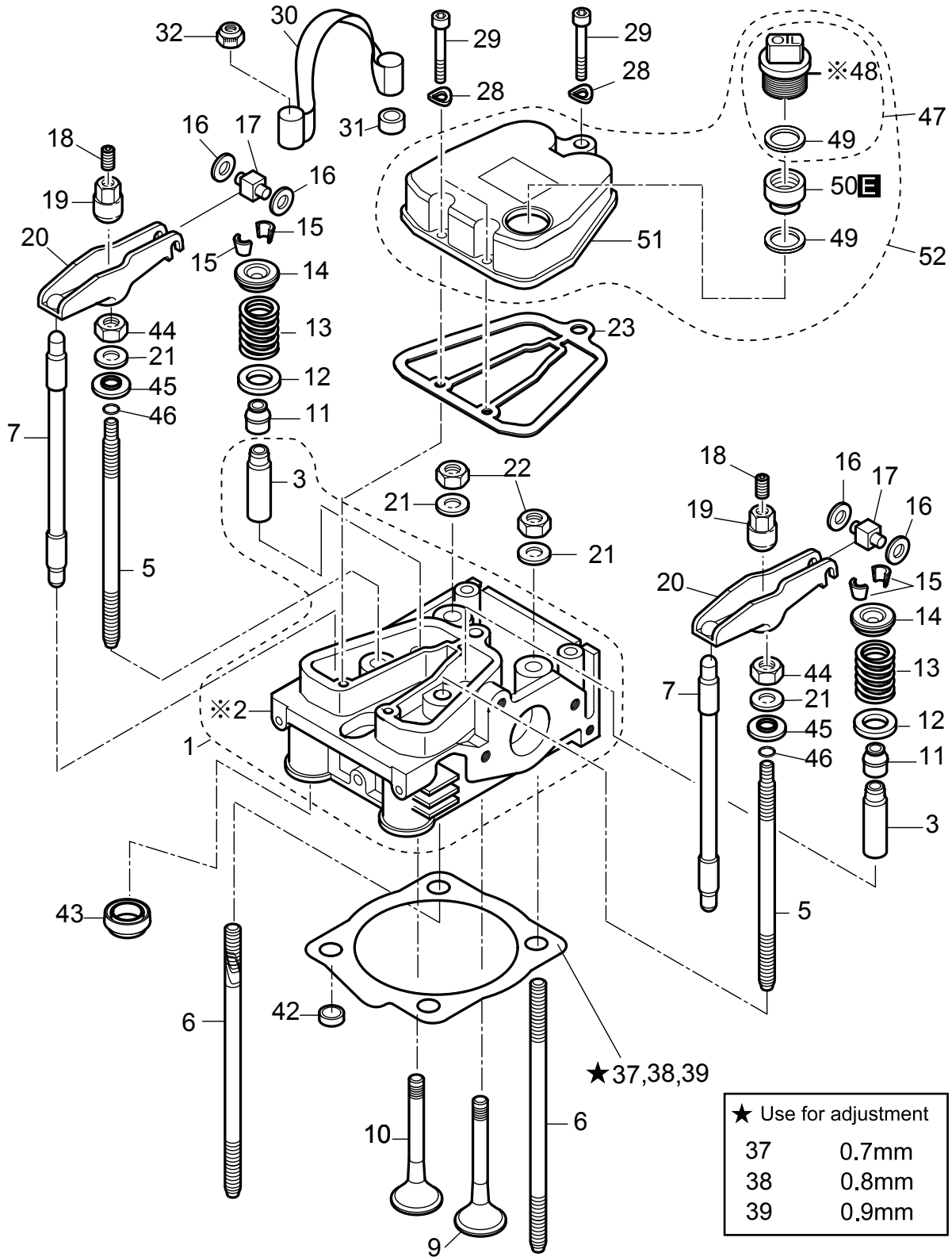

※ NOT SOLD SEPARATELY

HATZ 1B30 ENGINE — CYLINDER HEAD ASSY.

<u>NO.</u>	<u>PART NO.</u>	<u>PART NAME</u>	<u>QTY.</u>	<u>REMARKS</u>
D	70018918	LOCTITE 243, 50 ML	1	
E	50223400	LOCTITE 648, 50 ML	1	
1	01393610	CYLINDER HEAD ASSY.....	1.....	INCLUDES ITEMS W/\$
2\$		CYLINDER HEAD.....	1.....	NOT SOLD SEPARATELY
3\$	05129500	VALVE GUIDE	2	
5	05097500	STUD, CYLINDER HEAD	2	
6	05097400	STUD, CYLINDER HEAD	2	
7	05098900	PUSHROD	2	
9	05093000	VALVE INLET	1	
10	05093100	VALVE EXHAUST	1	
11	50631000	VALVE STEM SEAL CAP	2	
12	04093700	WASHER	2	
13	04113500	VALVE SPRING	2	
14	04093800	SPRING PLATE/RETAINER	2	
15	02252500	COLLET (COTTER)	2	
16	05240700	SUPPORT. DISC 6X12X1.35	1.....	SELECT 0-4
16	50445100	SUPPORT. DISC 6X12X1.2	1.....	SELECT 0-4
17	05091101	SLIDER	2	
18	50513100	GRUB SCREW	2	
19	05054700	NUT, F. ROCKER ARM	2	
20	05098202	ROCKER ARM	2	
21	05099300	WASHER	4	
22	50396600	HEXAGON NUT M10	2	
23	05093310	GASKET, CYLINDER HEAD COVER	1	
28	50081200	WASHER, LOCK A6	2	
29	50374900	ALLEN SCREW	2	
30	04117701	LIFTING STRAP	1	
32	50023800	HEXAGON NUT B	2	
33	05096301	GASKET F. CYLINDER HEAD 0.3	1.....	SELECT 0-1
34	05096401	GASKET, CYLINDER HEAD 0.4	1.....	SELECT 0-1
35-1	05096501	GASKET, CYLINDER HEAD 0.5	1.....	SELECT 0-1
35	04248800	GASKET, CYLINDER HEAD 0.55.....	1.....	SELECT 0-1

HATZ 1B30 ENGINE — CYLINDER HEAD ASSY(CONTINUED)

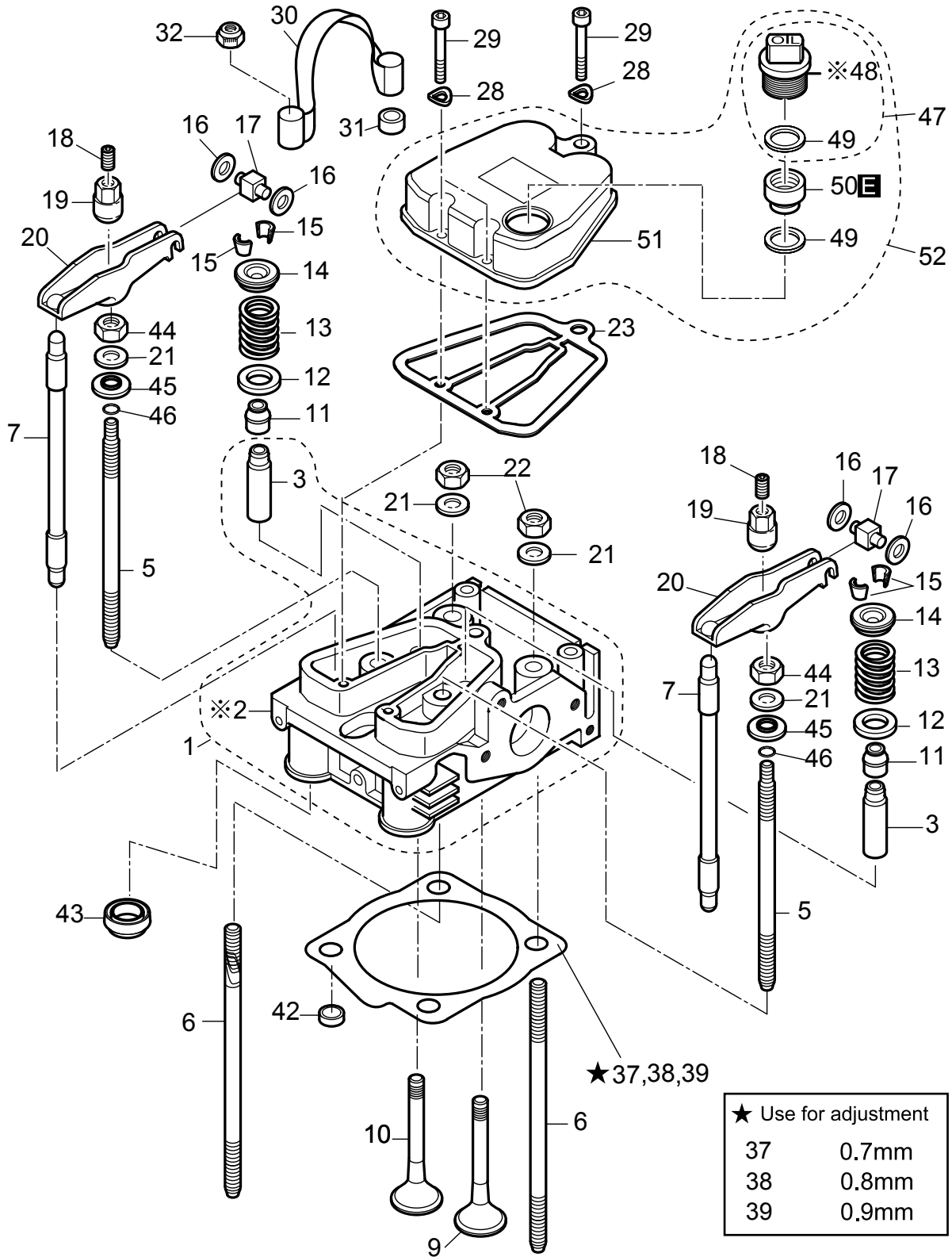

※ NOT SOLD SEPARATELY

HATZ 1B30 ENGINE — CYLINDER HEAD ASSY(CONTINUED)

<u>NO.</u>	<u>PART NO.</u>	<u>PART NAME</u>	<u>QTY.</u>	<u>REMARKS</u>
36-1	05096601	GASKET, CYLINDER HEAD 0.6	1.....	SELECT 0-1
36	04248900	GASKET, CYLINDER HEAD 0.65	1.....	SELECT 0-1
37-1	05096701	GASKET, CYLINDER HEAD 0.7	1.....	SELECT 0-1
37	04249000	GASKET, CYLINDER HEAD 0.75	1.....	SELECT 0-1
38	05096801	GASKET, CYLINDER HEAD 0.8	1.....	SELECT 0-1
39	05096901	GASKET, CYLINDER HEAD 0.9	1.....	SELECT 0-1
40	05097001	GASKET, CYLINDER HEAD 1.0	1.....	SELECT 0-1
42	04229000	CENTER BUSH	2	
43	04126100	PROTECTION HOSE	2	
44	50396600	HEXAGON NUT M10	2	
45	04243700	DISC	2	
46	50563900	O-RING	2	
47	01936500	CAP SCREW, CYL. HEAD COVER ASSY.	1.....	INCLUDES ITEMS W/@
48@ #		CAP SCREW, CYL. HEAD COVER	1.....	NOT SOLD SEPARATELY
49@#	05278401	SEALING RING	2	
50#	05321100	CONNECTING PIECE	1	
51#	05321210	COVER, CYLINDER HEAD	1	
52	01911201	COVER, CYLINDER HEAD ASSY.	1.....	INCLUDES ITEMS W/#

HATZ 1B30 ENGINE — OIL PUMP, GOVERNOR ASSY.

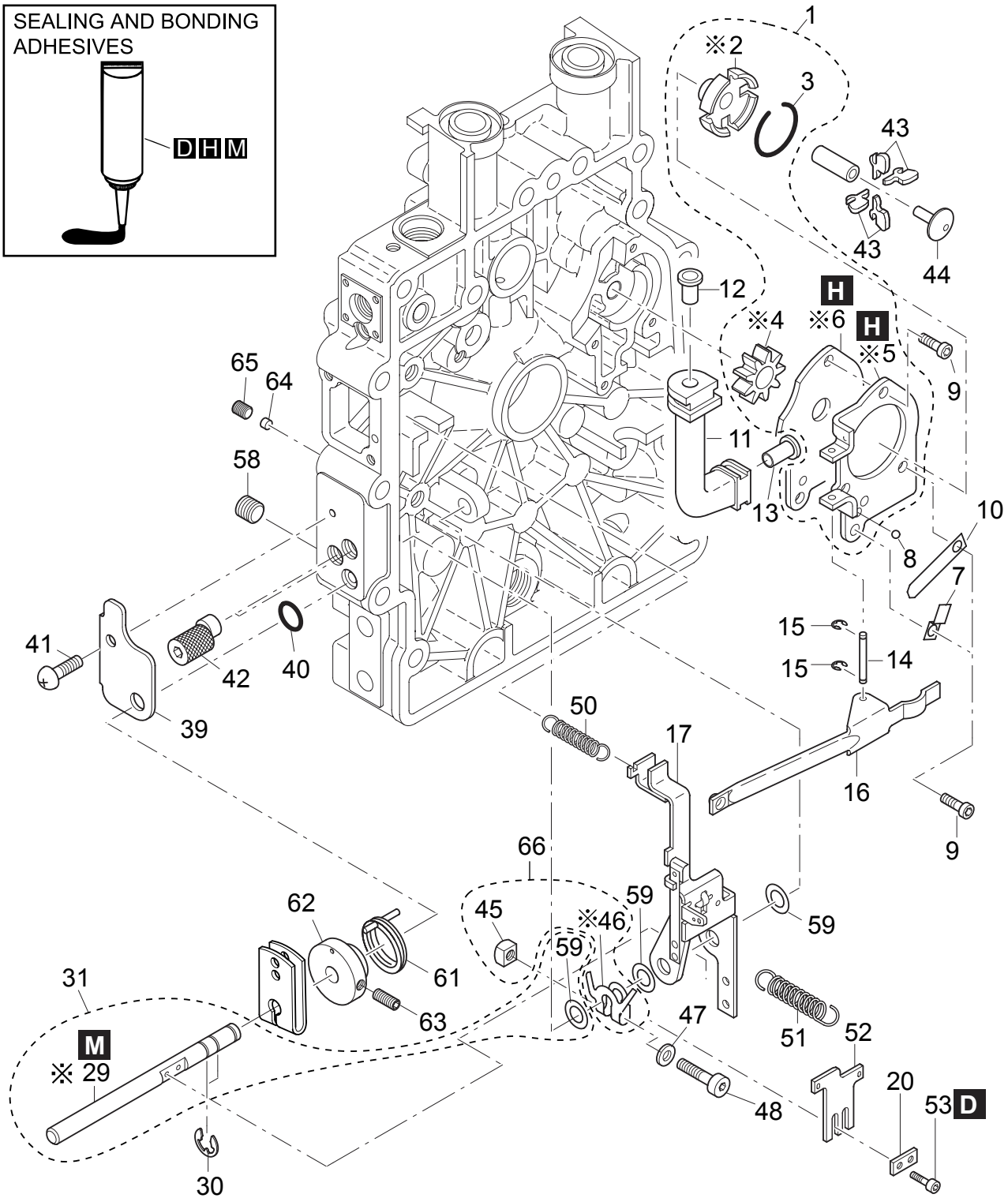
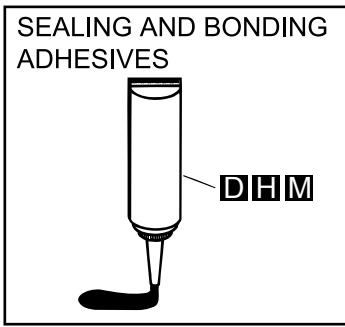

※ NOT SOLD SEPARATELY

HATZ 1B30 ENGINE — OIL PUMP, GOVERNOR ASSY.

<u>NO.</u>	<u>PART NO.</u>	<u>PART NAME</u>	<u>QTY.</u>	<u>REMARKS</u>
D	70018918	LOCTITE 243, 50 ML	1	
H	70018944	TEROSON TEROSTAT 63	1	
M	50485100	GRINDING PASTE 80ML	1	
1	01530220	COVER F. OIL PUMP ASSY.....	1	INCLUDES ITEMS W/\$
2\$		COVER PUMP	1	NOT SOLD SEPARATELY
3\$	04210910	CIRCLIP	1	
4\$		GEAR.....	1	NOT SOLD SEPARATELY
5\$		COVER F.....	1	NOT SOLD SEPARATELY
6\$		INNER PLATE.....	1	NOT SOLD SEPARATELY
7	05097100	RETAINING STRAP	1	
8	50447900	BALL	1	
9	50429400	ALLEN SCREW	4	
10	05097300	FLAT SPRING	1	
11	04102900	TUBE OIL SUCTION	1	
12	50447400	TUBE RIVET	1	
13	50447500	TUBE RIVET	1	
14	05078600	SHAFT	1	
15	50434800	CIRCLIP	2	
16	05079401	LEVER	1	
17	01530404	GOVERNOR LEVER	1	
29#		SHAFT	1	NOT SOLD SEPARATELY
30	50092700	CIRCLIP	2	
31	01981000	SHAFT AND SHIM ASSY.	1	INCLUDES ITEMS W/#
39	05178400	PLATE	1	
40	40022401	O-RING	1	
41	50492300	FILLISTER HEAD SCREW	1	
42	05178810	ECCENTRIC SCREW	2	
43	05079611	CENTRIFUGAL WEIGHT	4	
44	05078502	GOVERNOR SLEEVE	1	
45@	50094300	HEXAGON NUT	1	
46@		STOP	1	NOT SOLD SEPARATELY
47	50216300	WASHER	1	
48	50492200	ALLEN SCREW	1	
50	50563400	TENSION SPRING	1	
51	04290000	GOVERNOR SPRING	1	
52	05130800	STOP	1	
53	50465300	ALLEN SCREW	2	
58	50475700	GRUB SCREW	1	
59#	50422400	SHIM	3	
61	05154010	SPRING	1	
62	05179000	BUSH	1	
63	50400600	GRUB SCREW	1	
64	05307300	PLUG	1	
65	50574600	THREADED PIN	1	
66	02340300	STOP AND NUT ASSY.	1	INCLUDES ITEMS W/@

HATZ 1B30 ENGINE — TIMING COVER ASSY.

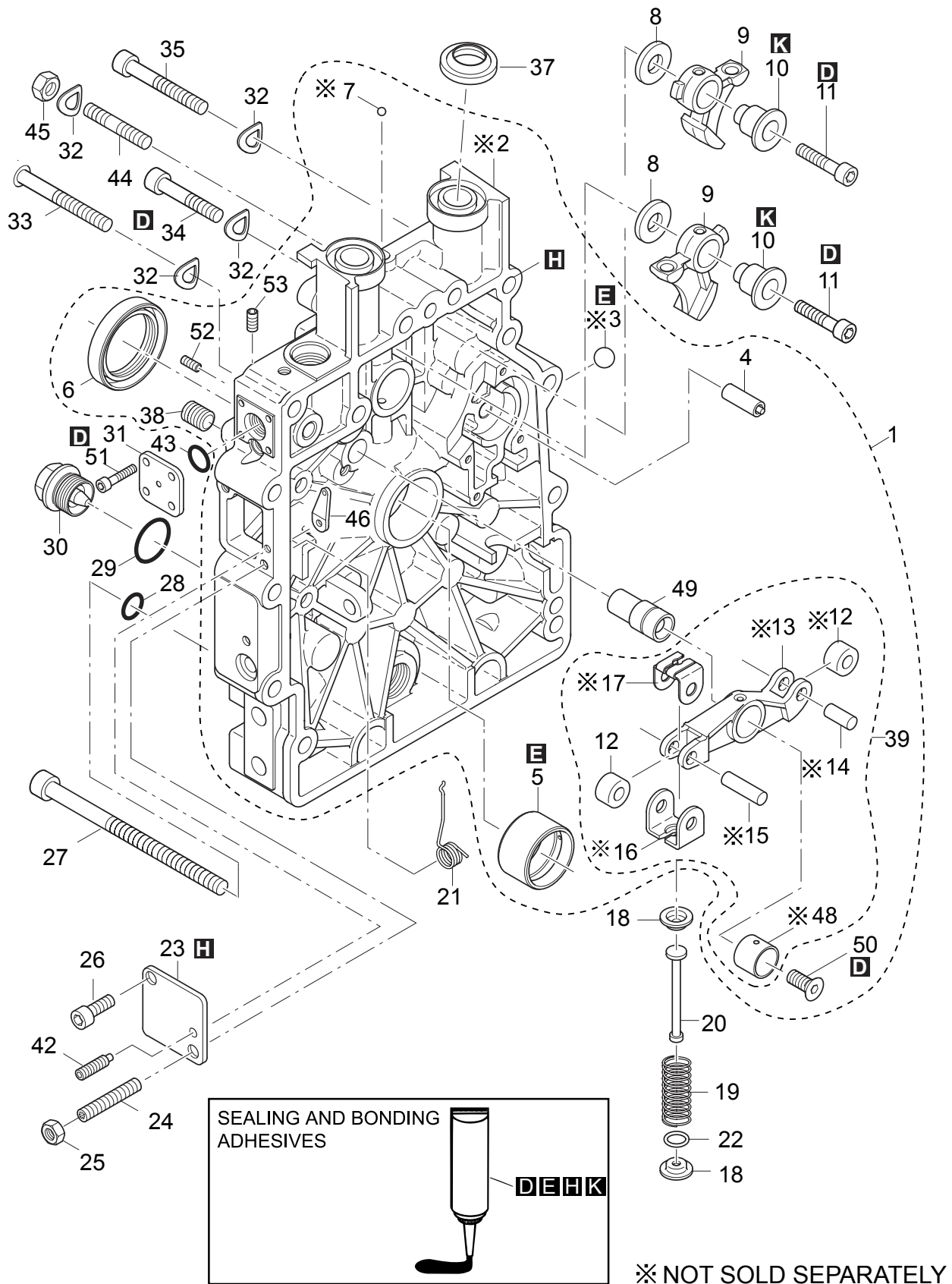

HATZ 1B30 ENGINE — TIMING COVER ASSY.

<u>NO.</u>	<u>PART NO.</u>	<u>PART NAME</u>	<u>QTY.</u>	<u>REMARKS</u>
D	70018918	LOCTITE 243, 50 ML	1	
E	50223400	LOCTITE 648, 50 ML	1	
H	70018944	TEROSON TEROSTAT 63	1	
K	50342601	HIGH TEMP. FETT 400G	1	
1	01319541	TIMING COVER ASSY.....	1	INCLUDES ITEMS W/\$
2\$		TIMING COVER.....	1	NOT SOLD SEPARATELY
3\$		PLUG	1	NOT SOLD SEPARATELY
4\$	01533900	BOLT, GOVERNOR HOUSING	1	
5\$	05053101	MAIN BEARING, STD	1	
5	04124801	MAIN BEARING, US -0.5	1	
6\$	40033701	OIL SEAL	1	
7\$		PLUG	1	NOT SOLD SEPARATELY
8	03794100	WASHER	1	
9	05053400	CAM FOLLOWER	1	
10	03794201	CAM FOLLOW SPINDLE	1	
11	50457900	ALLEN SCREW	1	
12%		BUSHING.....	2	NOT SOLD SEPARATELY
13%		ROCKER LEVER.....	1	NOT SOLD SEPARATELY
14%		PIN.....	1	NOT SOLD SEPARATELY
15%		PIN.....	1	NOT SOLD SEPARATELY
16%		CLAMP, LOWER.....	1	NOT SOLD SEPARATELY
17%		CLAMP, UPPER.....	1	NOT SOLD SEPARATELY
18	04094802	CUP	1	
19	04095700	PRESSURE SPRING	1	
20	04094700	DRAW ROD	1	
21	05095210	SPRING, GOVERNOR	1	
22	04133900	DISC	1	
23	04095210	COVER	1	
24	50448901	GRUB SCREW	1	
25	020106050	HEXAGON NUT	1	REPLACES P/N 50144400
26	50384200	ALLEN SCREW	1	
27	50463000	ALLEN SCREW	1	
28	50162900	JOINT A	1	
29	50001600	GASKET	1	
30	50373100	DRAIN PLG. MAGNETIC M22	1	
31	01351700	COVER	1	
32	50095100	WASHER, LOCK	1	
33	50248800	ALLEN SCREW	1	
34	50453401	ALLEN SCREW	1	
35	50392900	ALLEN SCREW	1	
37	04106501	SEALING RING, TIMING COVER	1	

HATZ 1B30 ENGINE — TIMING COVER ASSY. (CONTINUED)

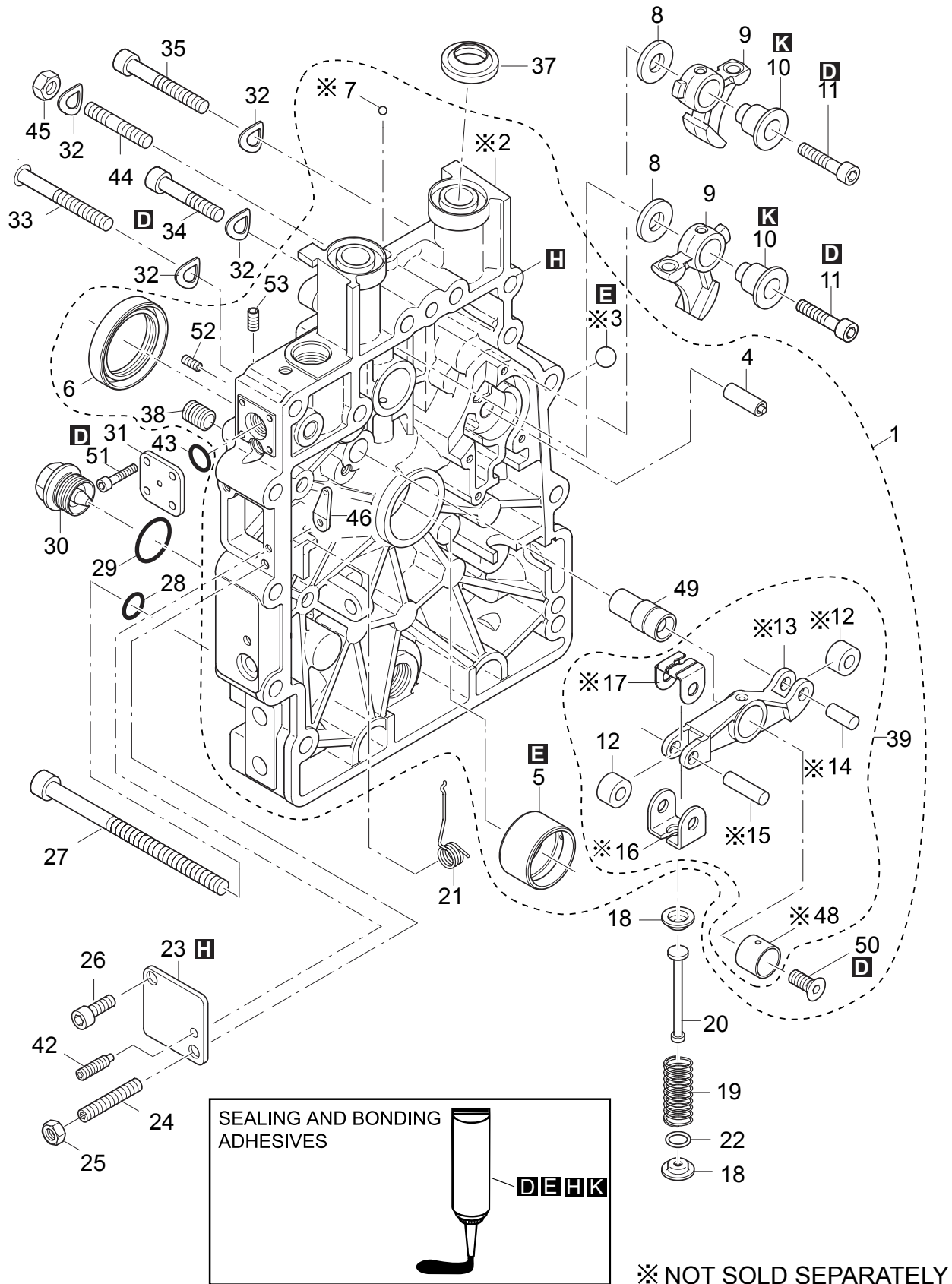

HATZ 1B30 ENGINE — TIMING COVER ASSY. (CONTINUED)

<u>NO.</u>	<u>PART NO.</u>	<u>PART NAME</u>	<u>QTY.</u>	<u>REMARKS</u>
38	50530600	GRUB SCREW	1	
39	01319620	ROCKER LEVER ASSY.....	1.....	INCLUDES ITEMS W/%
42	50274901	GRUB SCREW	1	
43	50329000	O-RING	1	
44	50038700	STUD	1	
45	020108060	HEXAGON NUT	1.....	REPLACES P/N 50148000
46	05127100	LEVER	1	
48%		BUSHING.....	1.....	NOT SOLD SEPARATELY
49	04096830	CAM FOLLOW SPINDLE	1	
50	50445000	COUNTERSUNK SCREW	1	
51	50397100	ALLEN SCREW	1	
52	50400600	GRUB SCREW	1	
53	50262400	THREADED PIN	1	

HATZ 1B30 ENGINE — BLOWER, FLYWHEEL ASSY.

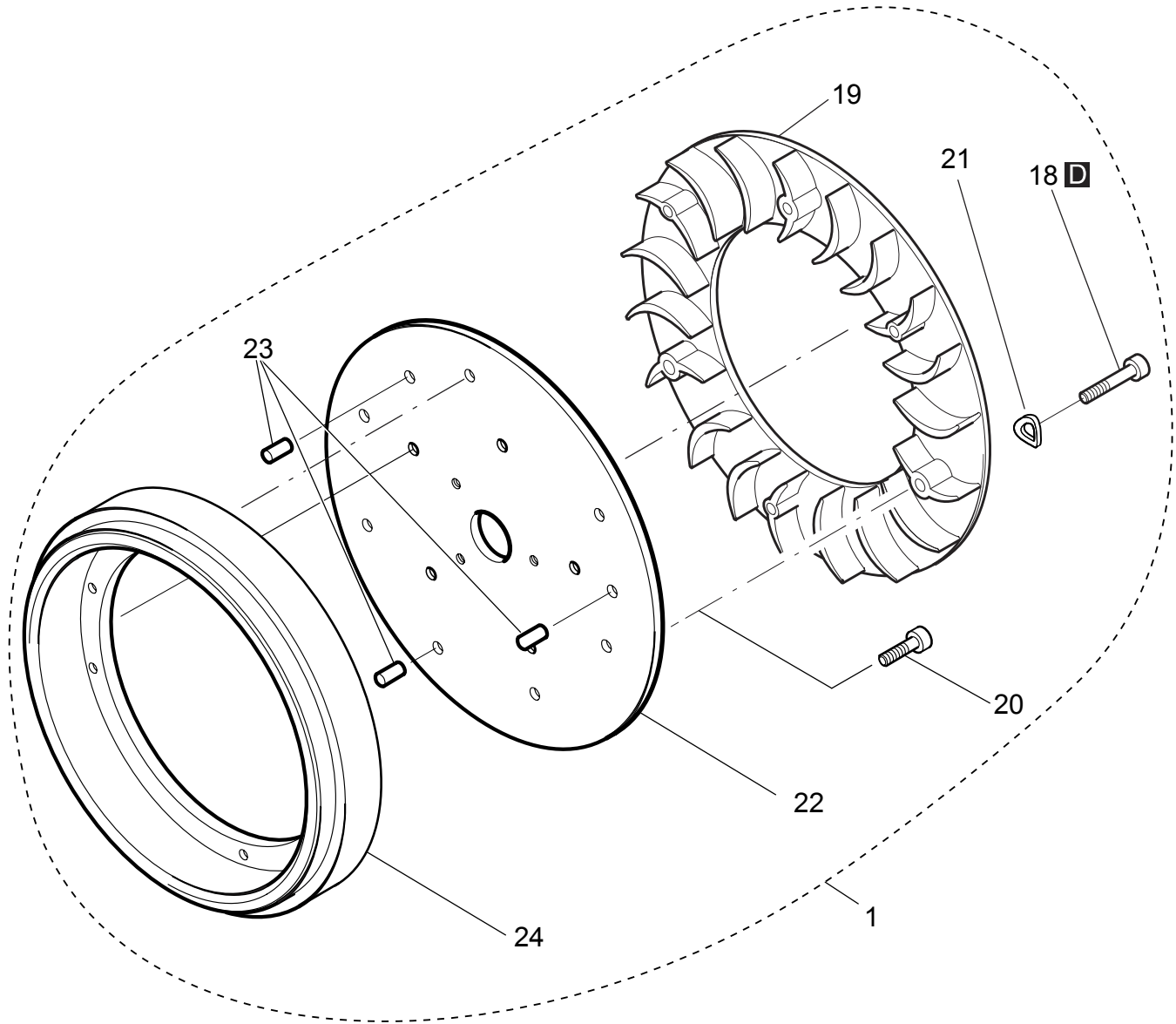

HATZ 1B30 ENGINE — BLOWER, FLYWHEEL ASSY.

<u>NO.</u>	<u>PART NO.</u>	<u>PART NAME</u>	<u>QTY.</u>	<u>REMARKS</u>
1	01330104	FLYWHEEL ASSY., ELECTRIC START	1.....	INCLUDES ITEMS W/\$
18\$	50327300	ALLEN SCREW	6	
19\$	04193600	BLOWER RING	1	
20\$	50416800	ALLEN SCREW	3	
21\$	50003400	WASHER, LOCK	6	
22\$	04098720	FLANGE	1	
23\$	50035200	PIN	3	
24\$	04110120	ADD. FLYWHEEL	1	

HATZ 1B30 ENGINE — INJECTION EQUIPMENT ASSY.

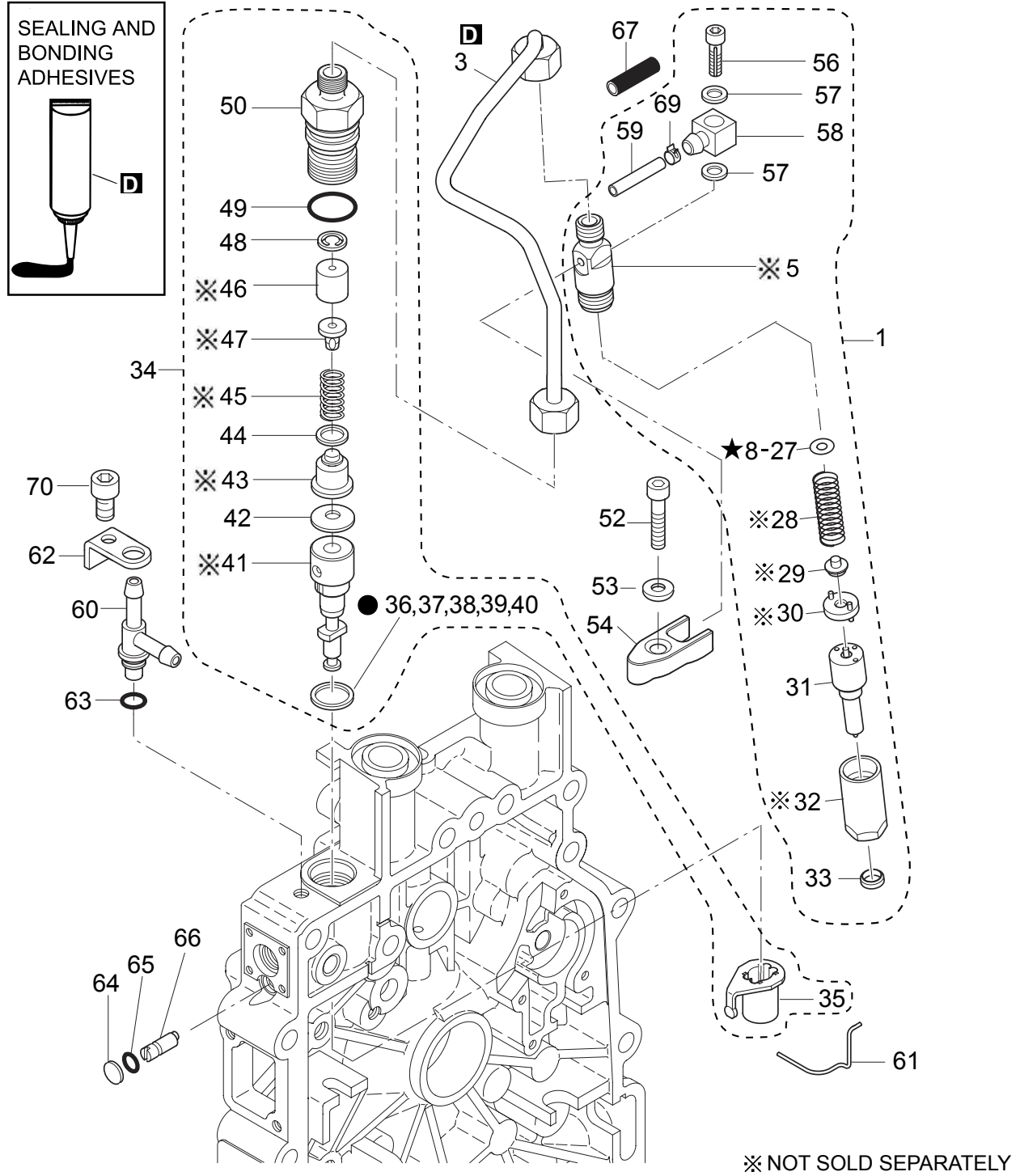

● Use for adjustment

36	0.2mm
37	0.3mm
38	0.4mm
39	0.5mm
40	0.6mm

★ Use for adjustment

8	1.00mm	13	1.24mm	18	1.50mm	23	1.74mm
9	1.04mm	14	1.30mm	19	1.54mm	24	1.80mm
10	1.10mm	15	1.34mm	20	1.60mm	25	1.84mm
11	1.14mm	16	1.40mm	21	1.64mm	26	1.90mm
12	1.20mm	17	1.44mm	22	1.70mm	27	1.94mm

※ NOT SOLD SEPARATELY

HATZ 1B30 ENGINE — INJECTION EQUIPMENT ASSY.

<u>NO.</u>	<u>PART NO.</u>	<u>PART NAME</u>	<u>QTY.</u>	<u>REMARKS</u>
D	70018918	LOCTITE 243, 50 ML	1	
1	01389610	INJECTOR ASSY.	1	INCLUDES ITEMS W/\$
3	02024400	FUEL PRESSURE PIPE	1	
5\$		HOUSING, INJECTOR	1	NOT SOLD SEPARATELY
8\$	50436400	SHIM 1.0	1	SELECT 0-1, ITEMS W/@
9@	50436500	SHIM 1.04	1	
10@	50436600	SHIM 1.10	1	
11@	50436700	SHIM 1.14	1	
12@	50436800	SHIM 1.20	1	
13@	50436900	SHIM 1.24	1	
14@	50437000	SHIM 1.30	1	
15@	50437100	SHIM 1.34	1	
16@	50437200	SHIM 1.40	1	
17@	50437300	SHIM 1.44	1	
18@	50437400	SHIM 1.50	1	
19@	50437500	SHIM 1.54	1	
20@	50437600	SHIM 1.60	1	
21@	50437700	SHIM 1.64	1	
22@	50437800	SHIM 1.70	1	
23@	50437900	SHIM 1.74	1	
24@	50438000	SHIM 1.80	1	
25@	50438100	SHIM 1.84	1	
26@	50438200	SHIM 1.90	1	
27@	50438300	SHIM 1.94	1	
28\$		HOUSING, INJECTOR	1	NOT SOLD SEPARATELY
29\$		SPRING	1	NOT SOLD SEPARATELY
30\$		GUIDE, INJECTOR SPRING	1	NOT SOLD SEPARATELY
31\$	50566710	NOZZLE	1	
32\$		BODY, INJECTOR.....	1	NOT SOLD SEPARATELY
33\$	05070500	JOINT WASHER INJECTOR	1	
34	01582920	INJECTION PUMP	1	
35	01330801	CONTROL SLEEVE	1	
36@	04096300	SHIM 14X18X0.2	1	
37@	04096400	SHIM 14X18X0.3	1	
38@	04096500	SHIM 14X18X0.4	1	
39@	04096600	SHIM 14X18X0.5	1	
40@	04096700	SHIM 14X18X0.6	1	
41%		VALVE, INJECTION PUMP	1	NOT SOLD SEPARATELY

HATZ 1B30 ENGINE — INJECTION EQUIP. ASSY(CONTINUED)

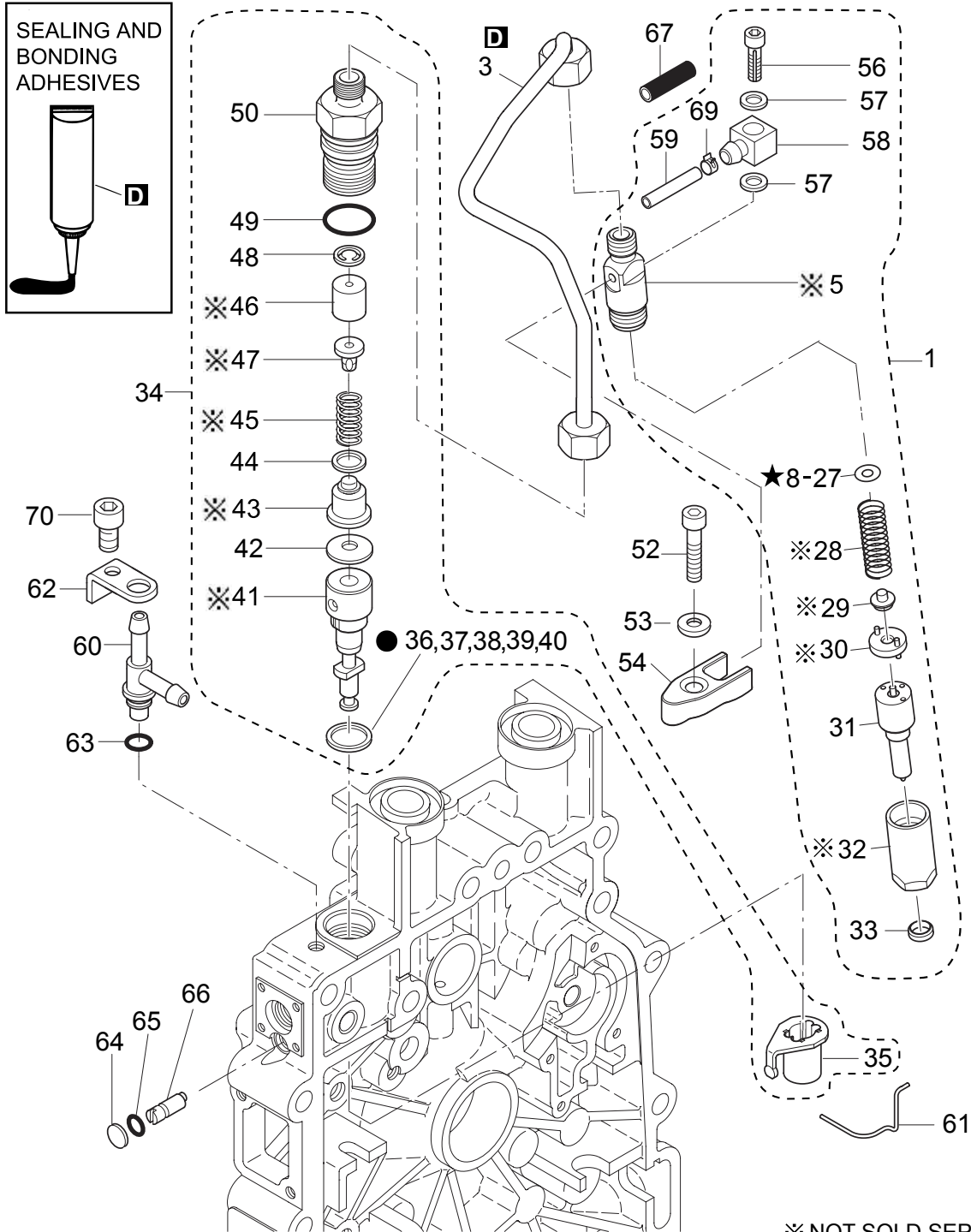

※ NOT SOLD SEPARATELY

● Use for adjustment	
36	0.2mm
37	0.3mm
38	0.4mm
39	0.5mm
40	0.6mm

★ Use for adjustment					
8	1.00mm	13	1.24mm	18	1.50mm
9	1.04mm	14	1.30mm	19	1.54mm
10	1.10mm	15	1.34mm	20	1.60mm
11	1.14mm	16	1.40mm	21	1.64mm
12	1.20mm	17	1.44mm	22	1.70mm
				23	1.74mm
				24	1.80mm
				25	1.84mm
				26	1.90mm
				27	1.94mm

HATZ 1B30 ENGINE — INJECTION EQUIP. ASSY(CONTINUED)

<u>NO.</u>	<u>PART NO.</u>	<u>PART NAME</u>	<u>QTY.</u>	<u>REMARKS</u>
42%	04165200	SEALING WASHER	1	
43%		VALVE COMPONENTS	1.....	NOT SOLD SEPARATELY
44%	50476900	JOINT WASHER	1	
45%		SPRING	1.....	NOT SOLD SEPARATELY
46%		SPACER.....	1.....	NOT SOLD SEPARATELY
47%		GUIDE, SPRING.....	1.....	NOT SOLD SEPARATELY
48%	05180800	VALVE PLATE	1	
49%	50489200	O-RING	1	
50%	05181100	HOLDER, DELIVERY VALVE	1	
52	50323900	ALLEN SCREW	1	
53	50596500	BALL DISC C	1	
54	04281801	FORK INJECTOR	1	
56\$	04281900	ALLEN SCREW	1	
57\$	50110800	JOINT A	2	
58\$	05129000	CONNECTING NIPPLE	1	
59\$	04282000	HOSE	1	
60	01756800	NIPPLE	1	
61	04161800	HOLDING SPRING	1	
62	05390700	SUPPORT	1	
63	50154300	O-RING	1	
64	50476000	DISC	1	
65	50330100	O-RING	1	
66	04097710	ECCENTRIC PIN	1	
67	05267901	INSULATION HOSE	1	
69\$	50577900	CLAMP 6	1	
70	50547000	ALLEN SCREW	1	

HATZ 1B30 ENGINE — RECOIL STARTER ASSY.

SEALING AND BONDING
ADHESIVES

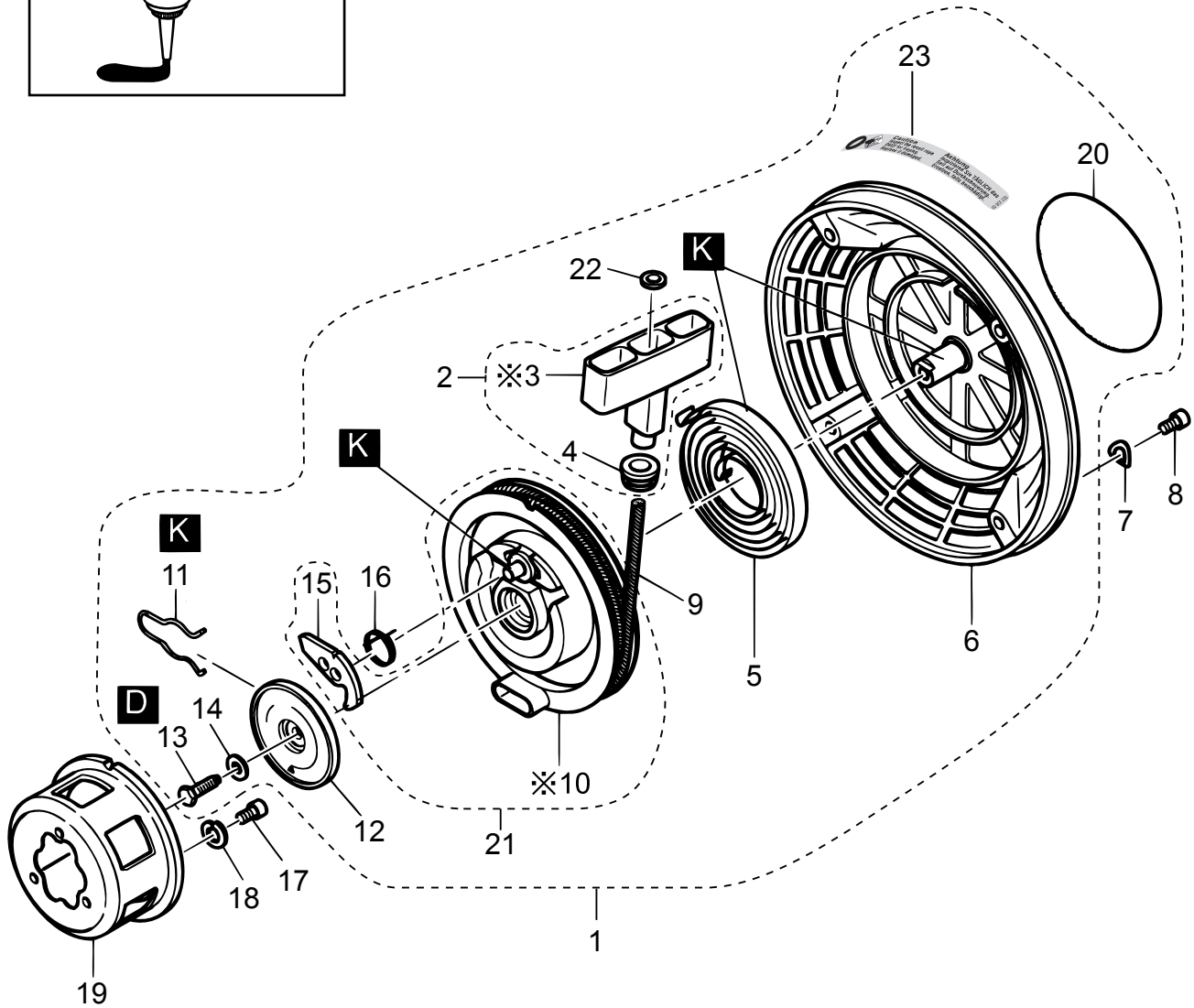
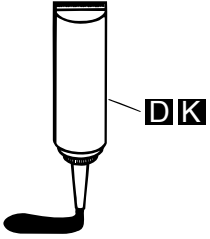

※ NOT SOLD SEPARATELY

HATZ 1B30 ENGINE — RECOIL STARTER ASSY.

<u>NO.</u>	<u>PART NO.</u>	<u>PART NAME</u>	<u>QTY.</u>	<u>REMARKS</u>
D	70018918	LOCTITE 243, 50 ML	1	
K	50342601	HIGH TEMP. FETT 400G	1	
1	01865501	RECOIL-STARTER ASSY.....	1	INCLUDES ITEMS W/\$
2\$	01497800	STARTER KNOB ASSY.	1	INCLUDES ITEMS W/%
3\$%		KNOB, STARTER.....	1	NOT SOLD SEPARATELY
4\$%	03665200	RUBBER SLEEVE	1	
5\$	05045202	SPIRAL SPRING	1	
6\$	02308100	CASE, RECOIL-STARTER	1	
7	50081200	WASHER, LOCK	4	
8	50062700	ALLEN SCREW	4	
9\$	01929000	ROPE RECOIL.	1	
10\$@		REEL.....	1	NOT SOLD SEPARATELY
11\$	05044901	BRAKE SPRING	1	
12\$	05045001	BRAKE DISC	1	
13\$	50146300	HEXAGON SCREW	1	
14\$	50390701	CON. WASHER, LOCK	1	
15\$@	05044800	RATCHET, RECOIL STARTER	1	
16\$	05061300	RETURN SPRING	1	
17	50062700	ALLEN SCREW	3	
18	50170900	WASHER, LOCK	3	
19	04155000	STARTER PULLEY	1	
20\$	05109103	STICKER LABEL	1	
21\$	01548800	REEL WITH RATCHET, RECOIL	1	INCLUDES ITEMS W/@
22\$	50514600	WASHER	1	
23\$	05333801	STICKER	1	

HATZ 1B30 ENGINE — AIR DUCTING ASSY.

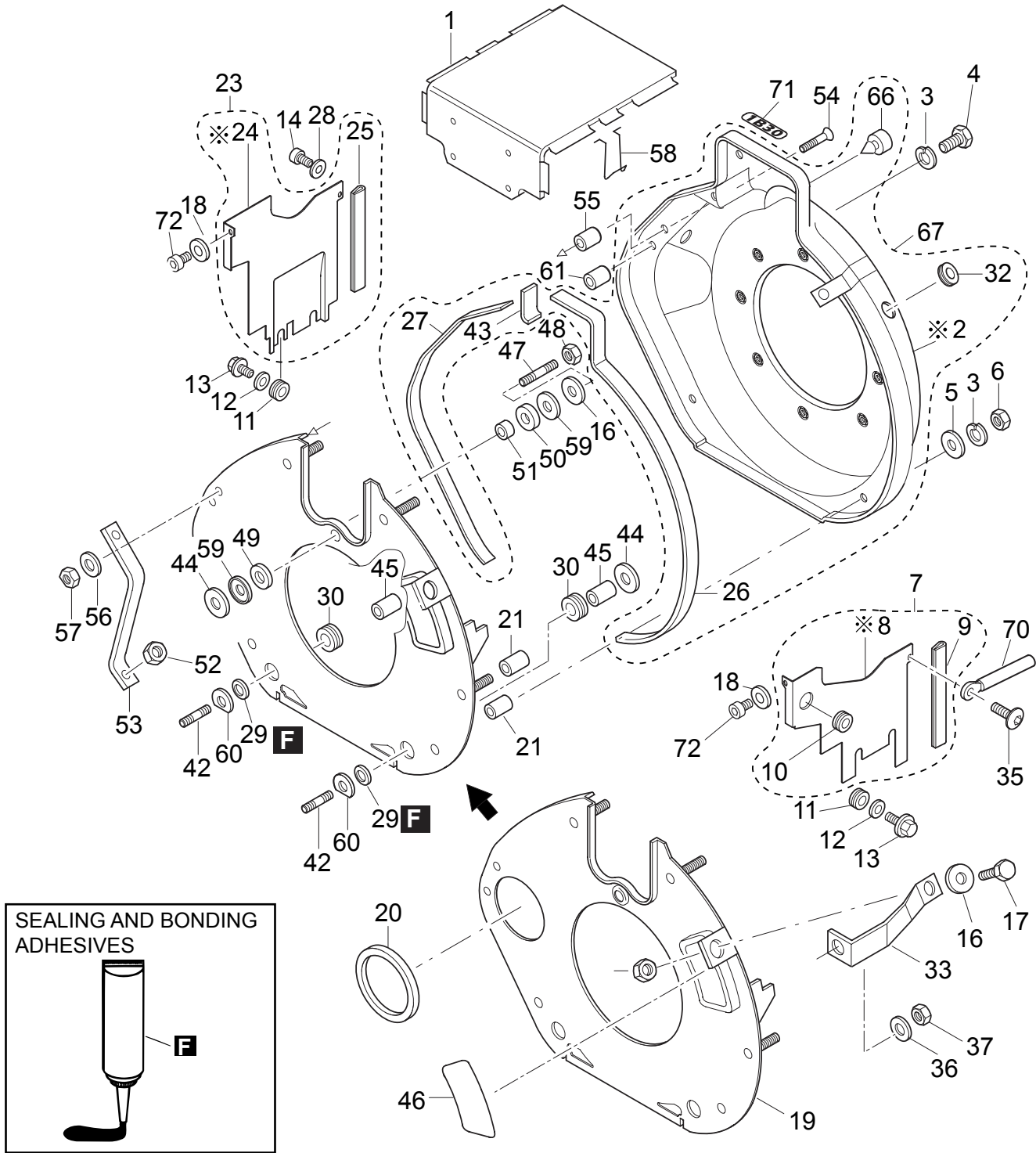

※ NOT SOLD SEPARATELY

HATZ 1B30 ENGINE — AIR DUCTING ASSY.

<u>NO.</u>	<u>PART NO.</u>	<u>PART NAME</u>	<u>QTY.</u>	<u>REMARKS</u>
F	50223900	TECHNICOLL CLEANER	1	
1	01910900	HOOD	1	
2#		DUCTING, COVER.....	1.....	NOT SOLD SEPARATELY
3	50170900	WASHER, LOCK	7	
4	50146300	HEXAGON SCREW	1	
5	50120000	DISC A	2	
6	020106050	HEXAGON NUT	6.....	REPLACES P/N 50144400
7	01326300	COOLING AIR DUCTING ASSY.....	1.....	INCLUDES ITEMS W/\$
8\$		DUCTING.....	1.....	NOT SOLD SEPARATELY
9\$	05128900	SEALING STRIP	1	
10\$	50334800	RUBBER SLEEVE	1	
11	50163801	RUBBER SLEEVE	3	
12	50441600	WASHER	3	
13	50445401	FILLISTER HEAD SCREW	3	
14	50528100	ALLEN SCREW	1	
15	020106050	HEXAGON NUT	1.....	REPLACES P/N 50144400
16	50114300	DISC	2	
17	50177100	HEXAGON SCREW	1	
18	50144500	WASHER, FLAT	2	
19	01326810	PARTING SHEET	1	
20	04099500	SEALING RING	1	
21	05197500	BUSH	4	
23	01326200	COOLING AIR DUCTING ASSY.	1.....	INCLUDES ITEMS W/%
24%		DUCTING.....	1.....	NOT SOLD SEPARATELY
25%	04111500	SEALING STRIP 119MM	1	
26#	05108101	SEALING STRIP 530MM	1	
27#	04124601	SEALING STRIP 443MM	1	
28	04060600	WASHER	1	
29	03575500	RUBBER SEAL RING	2	
30	01378300	SPACER BUSH	2	
32#	50453300	RUBBER SLEEVE	1	
33	01599610	SUPPORT	1	
35	50495000	SCREW	1	
36	50095100	WASHER, LOCK	1	
37	50344700	HEXAGON NUT	1	
42	50458100	STUD	2	
43#	05198200	SEALING STRIP 48	1	
44	04042000	WASHER	3	
45	04098400	SPACER TUBE	2	

HATZ 1B30 ENGINE — AIR DUCTING ASSY. (CONTINUED)

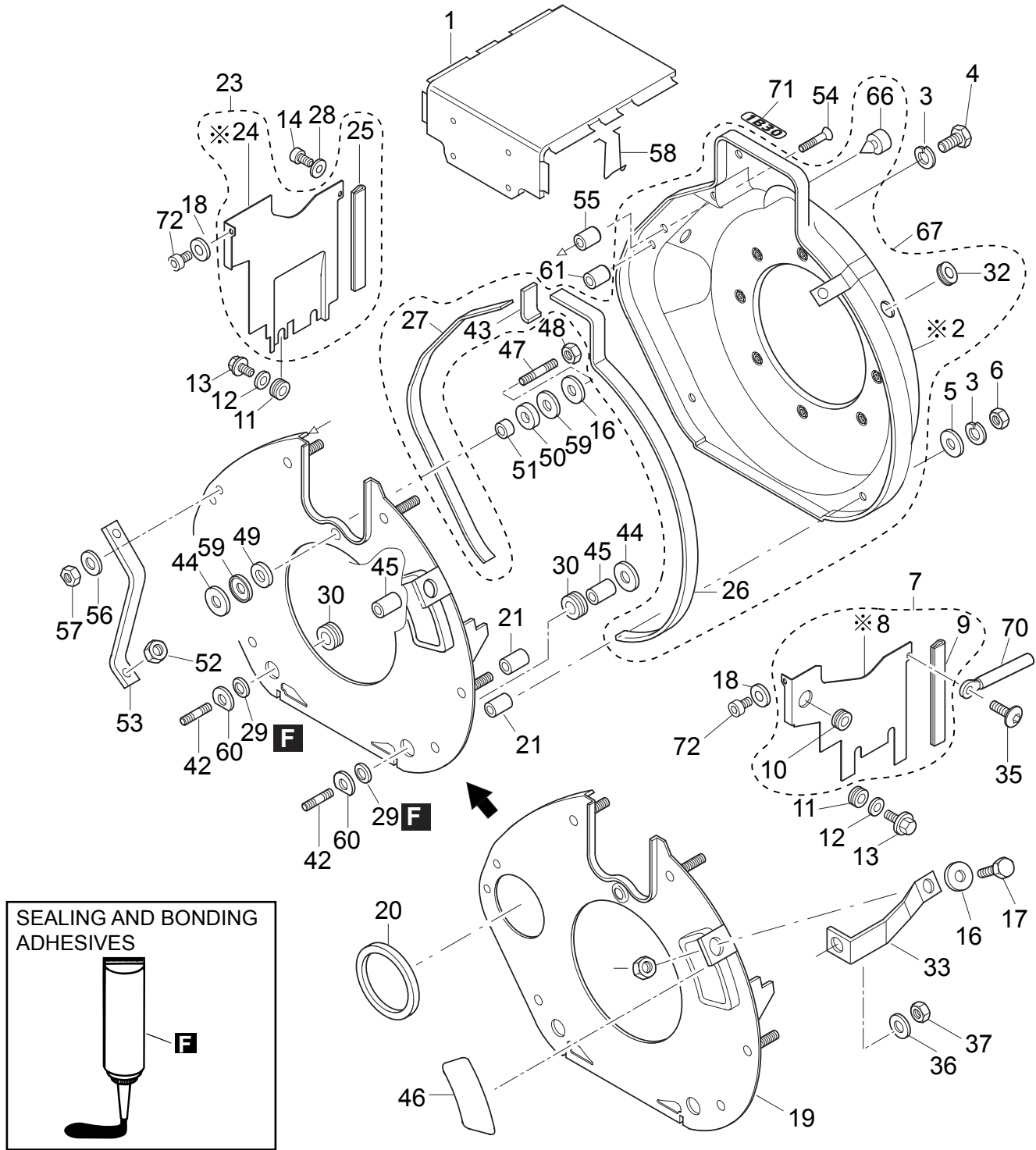

※ NOT SOLD SEPARATELY

HATZ 1B30 ENGINE — AIR DUCTING ASSY. (CONTINUED)

<u>NO.</u>	<u>PART NO.</u>	<u>PART NAME</u>	<u>QTY.</u>	<u>REMARKS</u>
46	04215000	CLOSING COVER	1	
47	50464401	STUD	1	
48	50328300	HEXAGON NUT	1	
49	05133800	RUBBER SEAL RING	1	
50	05133900	RUBBER SEAL RING	1	
51	05132700	BUSH	1	
52	020108060	HEXAGON NUT	1.....	REPLACES P/N 50148000
53	05133001	SUPPORT, FUEL TANK	1	
54	50445000	COUNTERSUNK SCREW	1	
55	05132810	SPACER TUBE	1	
56	50170900	WASHER, LOCK	1	
57	020106050	HEXAGON NUT	1.....	REPLACES P/N 50144400
58	05145800	SPRING CLIP	1	
59	05097600	WASHER	2	
60	04145300	DISC	2	
61	05132810	SPACER TUBE	1	
66#	50392610	RUBBER BUSH	1.....	SELECT 0-4
67	01831201	BLOWER DUCTING ASSY.....	1.....	INCLUDES ITEMS W/#
70	05001200	CLIP	1	
71	05314101	STICKER 1 1B30	1	
72	50474200	ALLEN SCREW	2	

HATZ 1B30 ENGINE — CRANKCASE BREATHING SYSTEM ASSY.

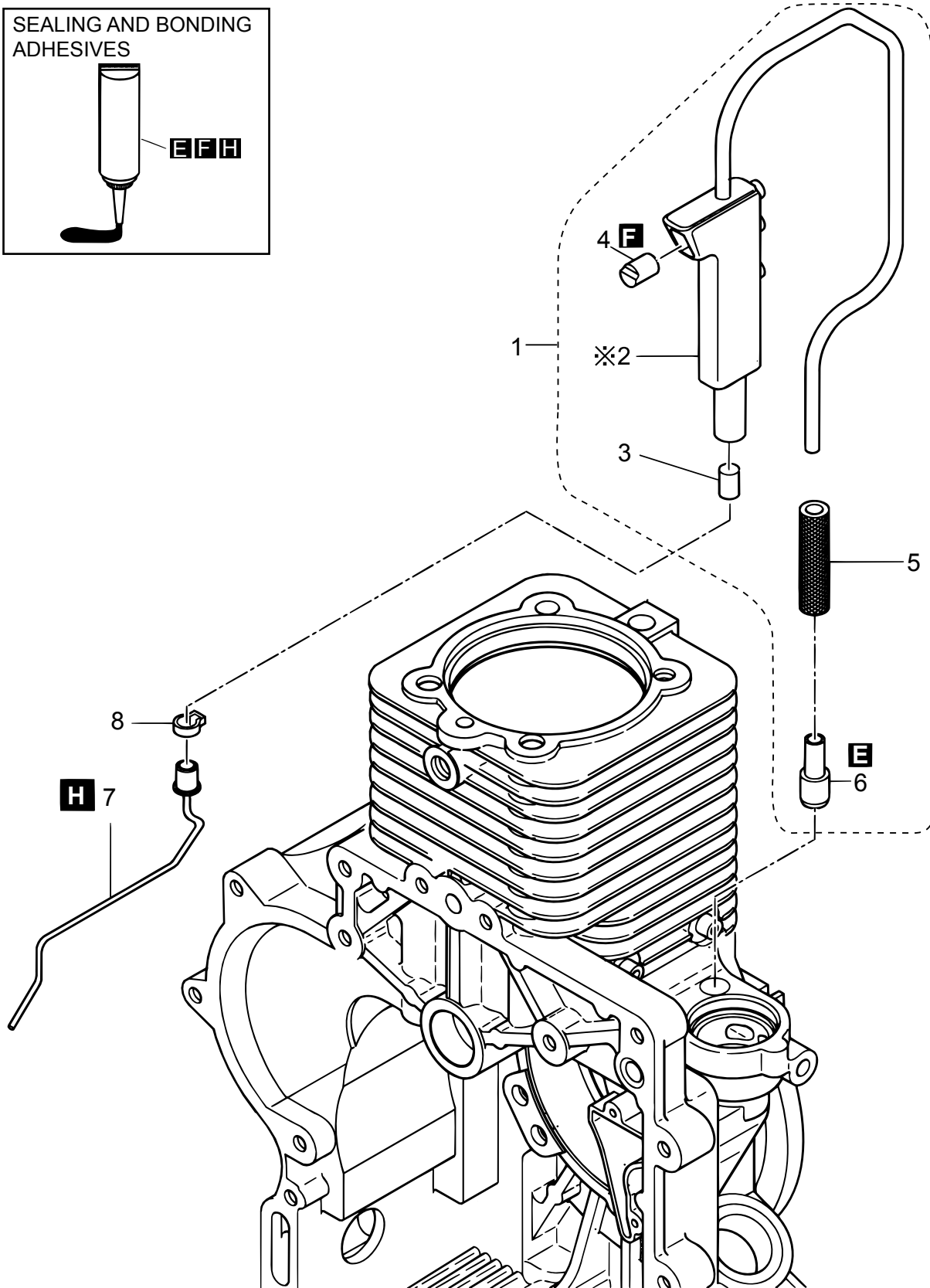
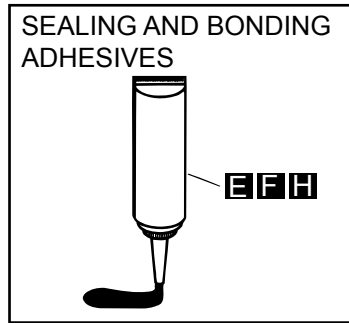

※ NOT SOLD SEPARATELY

HATZ 1B30 ENGINE — CRANKCASE BREATHING SYSTEM ASSY.

<u>NO.</u>	<u>PART NO.</u>	<u>PART NAME</u>	<u>QTY.</u>	<u>REMARKS</u>
E	50223400	LOCTITE 648	1	
G	50256501	LOCTITE IS 407	1	
H	70018944	TEROSON TEROSTAT 63	1	
1	01885700	CRANKCASE BREATHER ASSY.	1	INCLUDES ITEMS W/%
2%		HOUSING, CRANKCASE BREATHER.....	1	NOT SOLD SEPARATELY
3%	05102900	FILTER BREATHING SYSTEM	1	
4%	05098100	PLUG	1	
5%	05156200	FUEL PIPE LW 6X35	1	
6%	05306500	NIPPLE	1	
7	01551600	SUCTION PIPE	1	
8	50456800	CLAMP	1	

HATZ 1B30 ENGINE — FUEL ASSY.

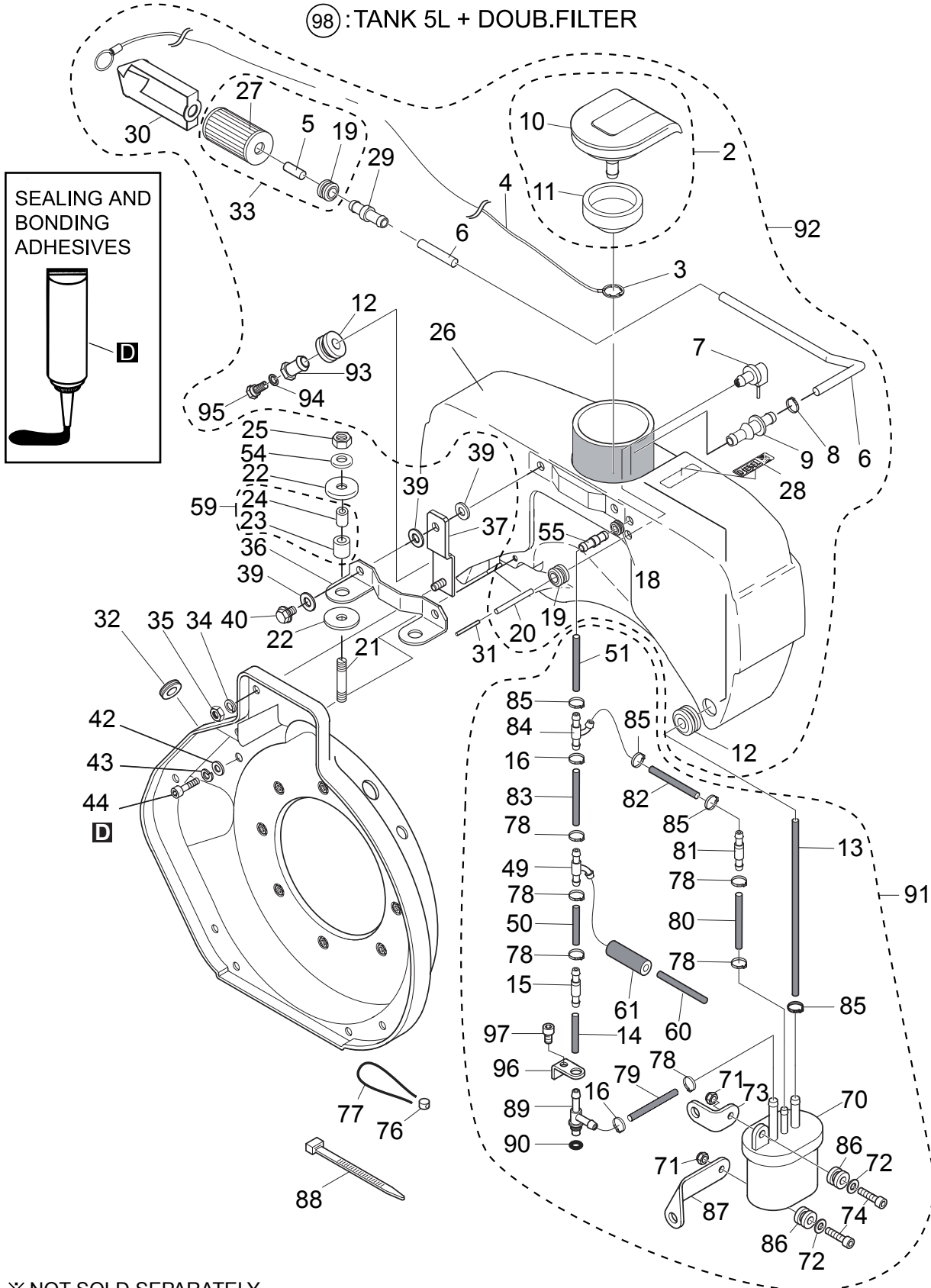

HATZ 1B30 ENGINE — FUEL ASSY.

<u>NO.</u>	<u>PART NO.</u>	<u>PART NAME</u>	<u>QTY.</u>	<u>REMARKS</u>
D	70018918	LOCTITE 243, 50 ML	1	
2^	01535302	CAP, FUEL TANK ASSY.....	1	INCLUDES ITEMS W/\$
3^	50500800	CIRCLIP 8	1	
4^	01628900	ROPE	1	
5% [^]		TUBE	1	NOT SOLD SEPARATELY
6^	05311000	FUEL HOSE	1	
7^	01534900	FUEL VENTING VALVE	1	
8^	50399801	CLAMP	1	
9^	05084010	CONNECTING NIPPLE	1	
10\$ [^]		FUEL CAP	1	NOT SOLD SEPARATELY
11\$ [^]	05086401	GASKET, FUEL CAP	1	
12^	50440800	RUBBER SLEEVE	2	
13#	05347600	FUEL HOSE	1	
14#	05366400	FUEL PIPE	1	
15#	01534601	FUEL VENTING VALVE	1	
16#	50590000	CLAMP	2	
18^	05130400	RUBBER SLEEVE	1	
19% [^]	50440901	RUBBER SLEEVE	2	
20^	05085601	BREATHER HOSE	1	
21	50231900	STUD	2	
22	05109810	DISC	4	
23@		TUBE, INSULATING	1	NOT SOLD SEPARATELY
24@	05122800	INSULATING SLEEVE	2	
25	020108060	HEXAGON NUT	2	REPLACES P/N 40028400
26^		FUEL TANK.....	1	NOT SOLD SEPARATELY
27% [^]		FILTER, FUEL.....	1	NOT SOLD SEPARATELY
28^	05235602	STICKER DIESEL	1	
29^	05189001	CONNECTING NIPPLE	1	
30^	05253400	SUPPORT FUEL FILTER	1	
31	05085500	TUBE	1	
33	01635210	FUEL FILTER ASSY.....	1	INCLUDES ITEMS W/%
34	50170900	WASHER, LOCK	2	
35	020106050	HEXAGON NUT	2	REPLACES P/N 50144400
36	05122300	SUPPORT	1	
37	01331300	SUPPORT	2	
39	05110010	DISC	4	
40	01677100	HEXAGON SCREW	2	
42	50144500	WASHER, FLAT	4	
43	50170900	WASHER, LOCK	4	
44	50149100	ALLEN SCREW	4	
49#	05175602	HOSE NIPPLE T	1	
50#	03807110	FUEL HOSE	1	

HATZ 1B30 ENGINE — FUEL ASSY. (CONTINUED)

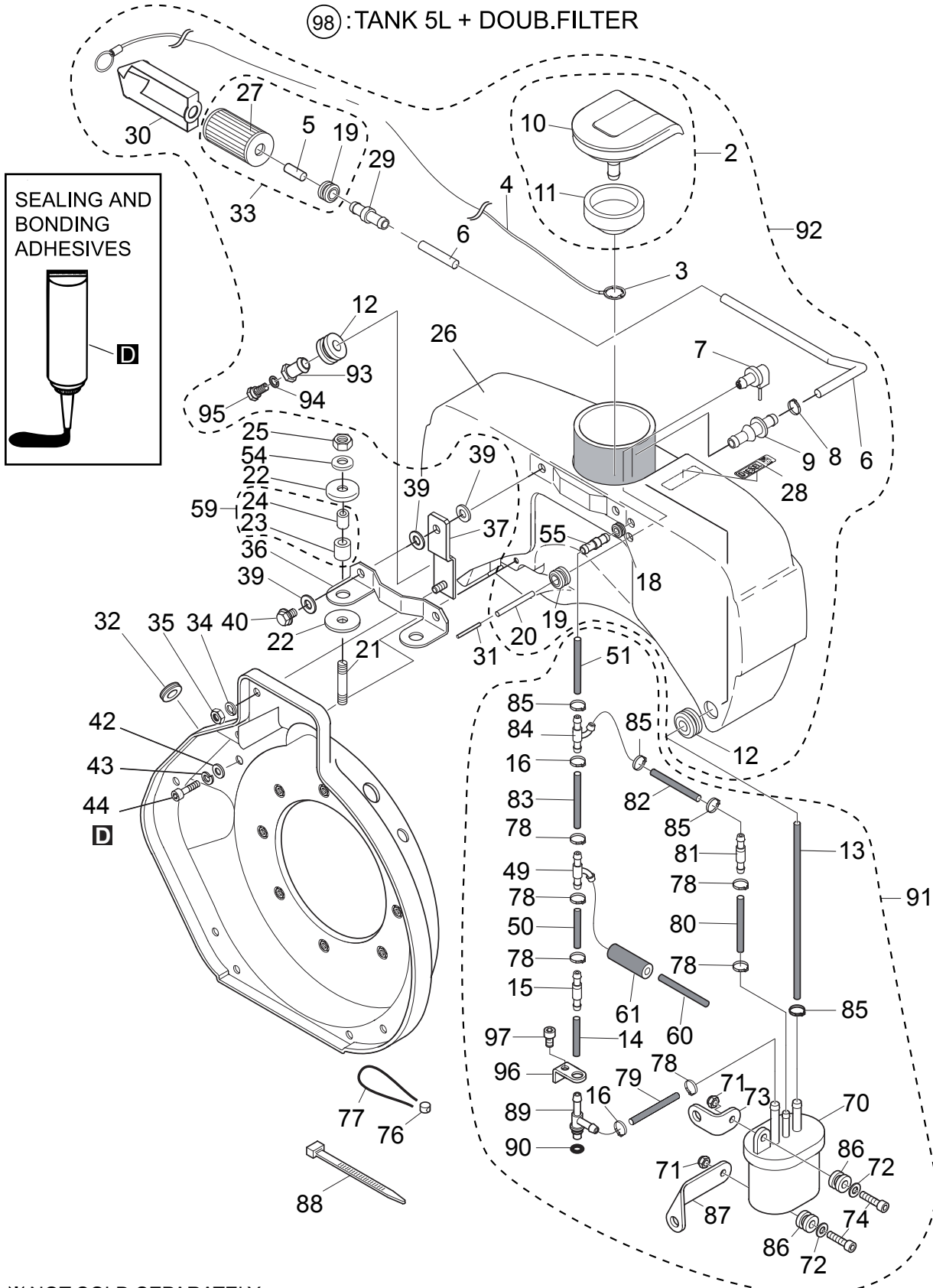

※ NOT SOLD SEPARATELY

HATZ 1B30 ENGINE — FUEL ASSY. (CONTINUED)

<u>NO.</u>	<u>PART NO.</u>	<u>PART NAME</u>	<u>QTY.</u>	<u>REMARKS</u>
51#	05306900	FUEL HOSE	1	
54	50148100	FLAT WASHER	2	
55^	05184400	CONNECTING NIPPLE	1	
59	01655800	INSULATING TUBE ASSY.	2.....	INCLUDES ITEMS W/@
60	04282000	HOSE	1	
61	05213010	INSULATION HOSE	1	
70#	01919702	FUEL FILTER EXTENSION MOUNT	1	
71#	50501600	HEXAGON NUT	2	
72#	50441600	WASHER	2	
73#	05279500	SUPPORT	1	
74#	50446900	ALLEN SCREW	2	
76#	40021400	LEAD SEAL	1	
77#	40021500	SEAL WIRE	1	
78#	50570900	CLAMP	6	
79#	05283910	FUEL PIPE	1	
80#	05283910	FUEL PIPE	1	
81#	00805502	VENT VALVE	1	
82#	03663710	FUEL HOSE	1	
83#	03663810	FUEL HOSE	1	
84#	05122701	HOSE NIPPLE T	1	
85#	50399801	CLAMP	4	
86#	50556600	RUBBER SLEEVE	2	
87#	05279400	SUPPORT	1	
88	50358400	STRAP	2	
89#	01756800	NIPPLE	1	
90#	50154300	O-RING	1	
91	02299300	FUEL PIPE ASSY.	1.....	INCLUDES ITEMS W/#
92	01790500	FUEL TANK ASSY. 5L	1.....	INCLUDES ITEMS W/^
93^	05188200	CONNECTING NIPPLE	1	
94^	50313100	JOINT A	1	
95^	03613600	VENT SCREW	1	
96#	05390700	SUPPORT	1	
97#	50547000	ALLEN SCREW	1	
98	01832704	TANK 5L + DOUB. FILTER	1.....	INCLUDES ALL ITEMS OF ASSY ITEMS 91 AND 92

HATZ 1B30 ENGINE — AIR FILTER ASSY.

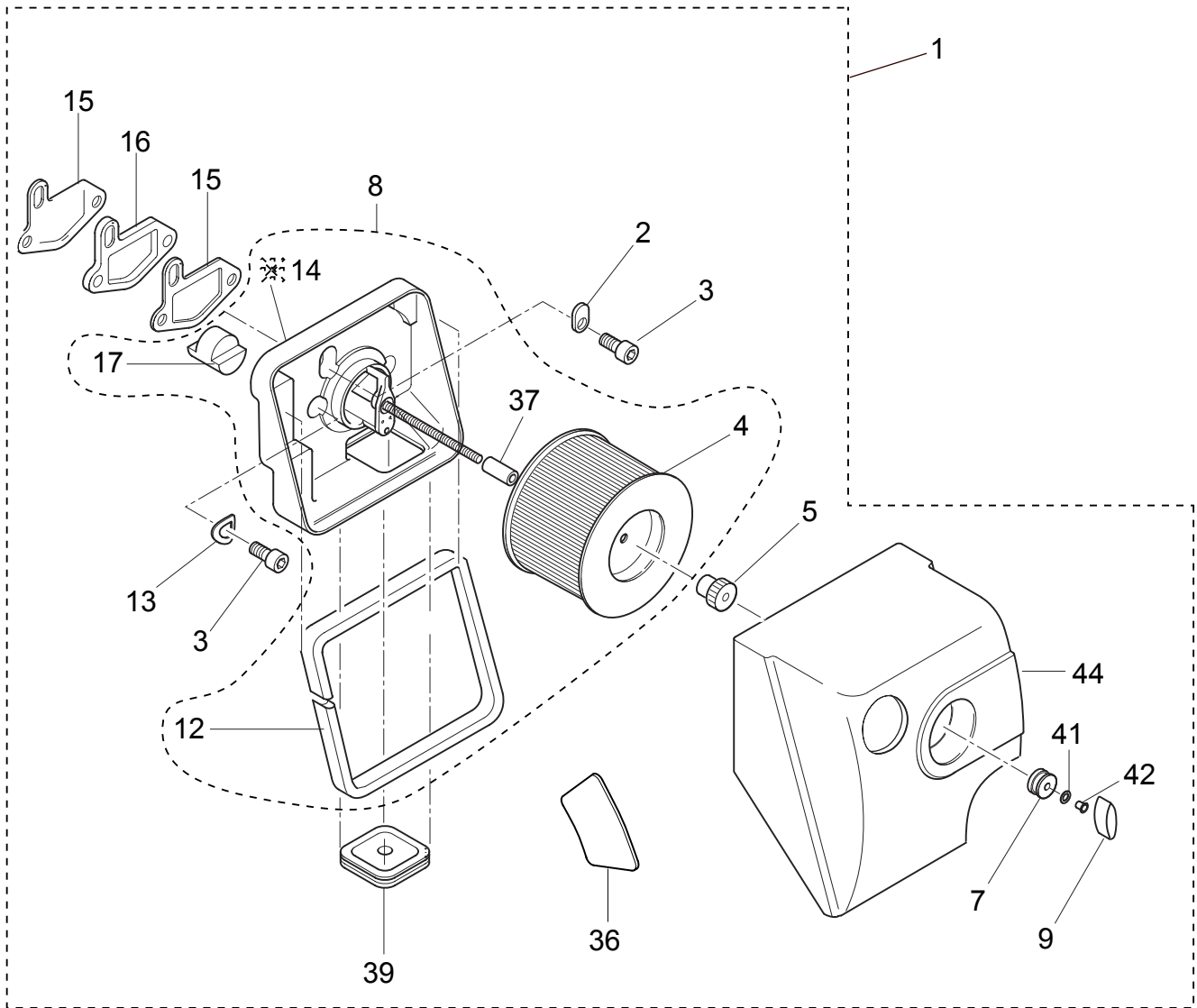

※ NOT SOLD SEPARATELY

HATZ 1B30 ENGINE — AIR FILTER ASSY.

<u>NO.</u>	<u>PART NO.</u>	<u>PART NAME</u>	<u>QTY.</u>	<u>REMARKS</u>
G	50256501	LOCTITE IS 407	1	
1	01713601	AIR FILTER INTAK. ASSY. TOP	1	INCLUDES ITEMS W/#
2#	05056400	WASHER	1	
3#	50171500	ALLEN SCREW	3	
4#	50426000	AIR FILTER ELEMENT	1	
5#	50454300	KNURLED NUT	1	
7#	50435800	RUBBER SLEEVE	1	
8#	01607911	AIR FILTER HOUSING	1	INCLUDES ITEMS W/\$
9#	50452200	WING NUT	1	
12#	05216100	SEALING STRIP 545MM	1	
13#	50095100	WASHER, LOCK	2	
14#		HOUSING, AIR FILTER	1	NOT SOLD SEPARATELY
15#	05056300	GASKET AIR FILTER	2	
16#	05088301	INSULATING FLANGE	1	
17#	05098100	PLUG	1	
36#	04215000	CLOSING COVER	1	
37#	05166200	RUBBER SHELL 32MM	1	
39#	05056500	CLOSING COVER	1	
41#	50591500	SHIM	1	
42#	50591600	TUBE RIVET	1	
44#	01720201	COVER AIR FILTER	1	

HATZ 1B30 ENGINE — EXHAUST SILENCER ASSY.

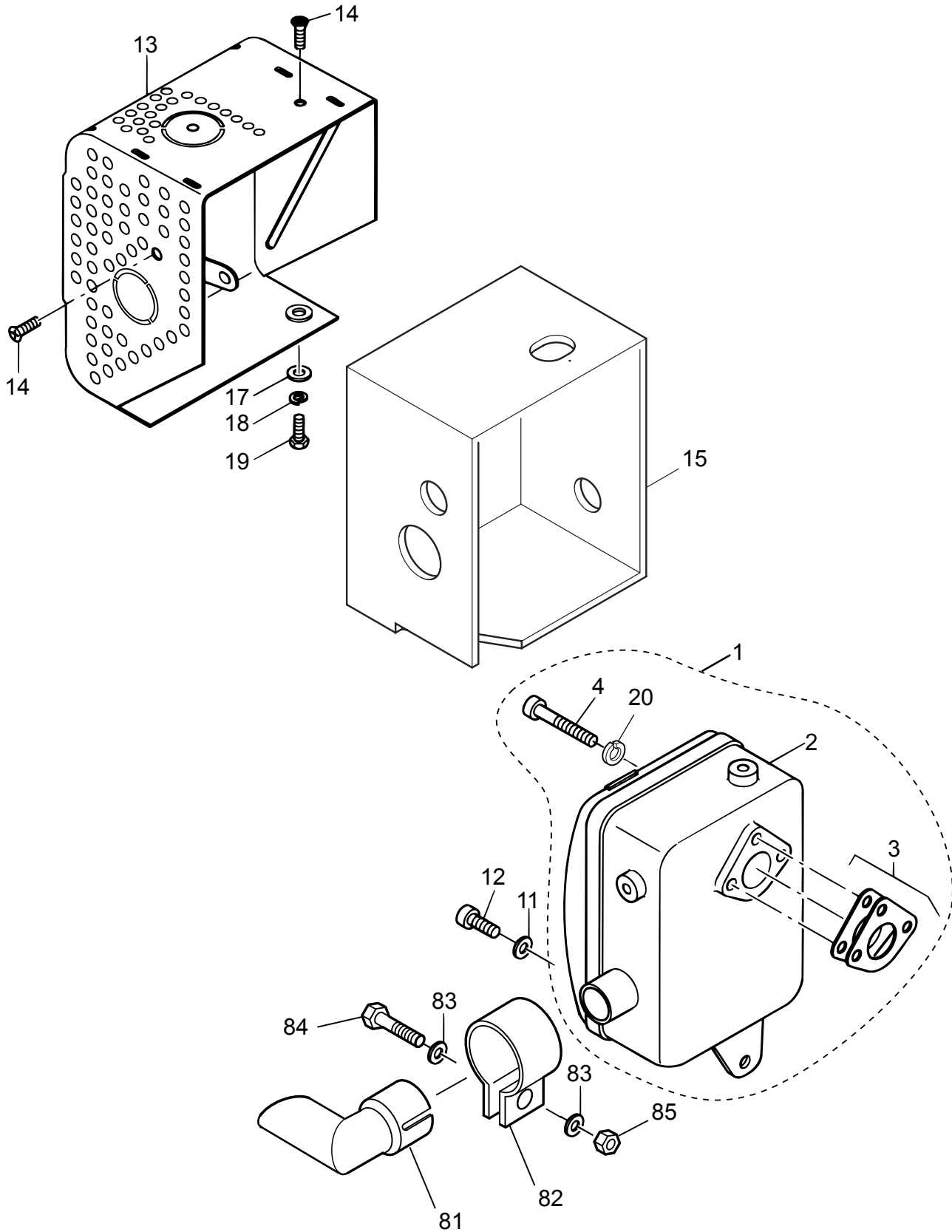

※ NOT SOLD SEPARATELY

HATZ 1B30 ENGINE — EXHAUST SILENCER ASSY.

<u>NO.</u>	<u>PART NO.</u>	<u>PART NAME</u>	<u>QTY.</u>	<u>REMARKS</u>
1	01680902	EXHAUST SILENCER ASSY.....	1.....	INCLUDES ITEMS W/\$
2\$	01680420	EXHAUST SILENCER	1	
3\$	01732601	GASKET, EXHAUST SILENCER	1	
4\$	50403900	ALLEN SCREW	3	
11	50114300	DISC	1	
12	50474200	ALLEN SCREW	1	
13	01645720	PROTECTOR, GUARD EXHAUST	1	
14	50422501	COUNTERSUNK SCREW	2	
15	01981301	INSULATION, EXHAUST SILENCER	1	
17	50114300	DISC	1	
18	50170900	WASHER, LOCK	1	
19	50177100	HEXAGON SCREW	1	
20\$	50208500	WASHER, LOCK	3	
81	467466780	EXHAUST PIPE	1	
82	50639700	PIPE CLIP	1	
83	50148100	WASHER, FLAT	2	
84	50135400	HEXAGON SCREW	1	
85	020108060	HEXAGON NUT	1.....	REPLACES P/N 40028400

HATZ 1B30 ENGINE — STARTER, ALTERNATOR ASSY.

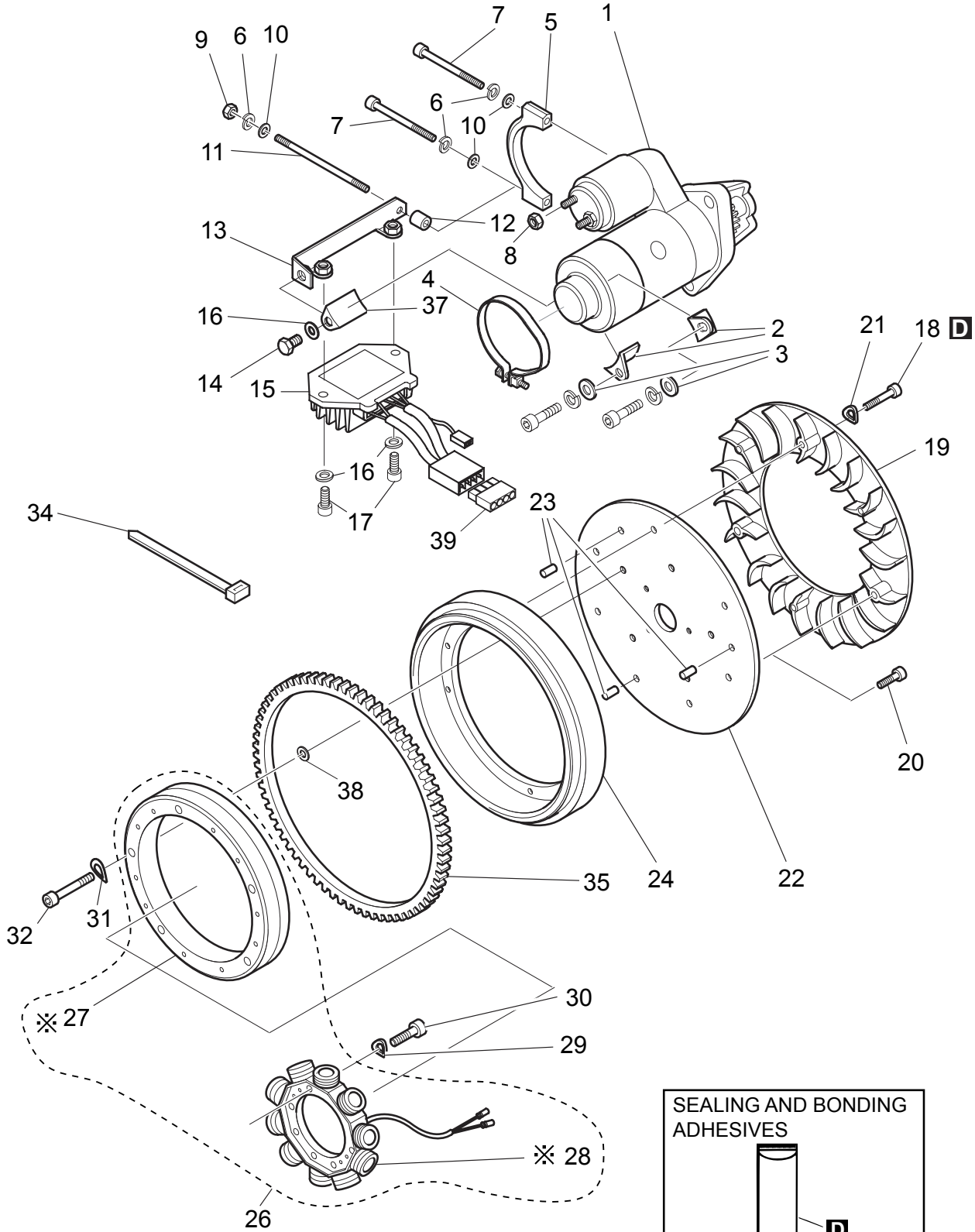

※ NOT SOLD SEPARATELY

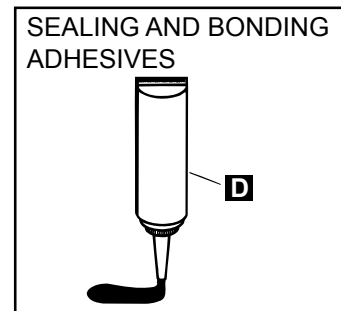

HATZ 1B30 ENGINE — STARTER, ALTERNATOR ASSY.

<u>NO.</u>	<u>PART NO.</u>	<u>PART NAME</u>	<u>QTY.</u>	<u>REMARKS</u>
D	70018918	LOCTITE 243 50ML	1	
1	01723400	ELECTRIC STARTER 12V 1.0KW	1	
2	04138400	SUPPORT	2	
3	50148100	FLAT WASHER	2	
4	50529800	HOSE CLIP	1	
5	04099100	RETAINING BRACKET	1	
6	50170900	WASHER, LOCK	2	
7	50444300	ALLEN SCREW	2	
8	50344700	HEXAGON NUT	1	
9	50144400	HEXAGON NUT	1	
10	50144500	WASHER, FLAT	2	
11	50455900	STUD MFS	1	
12	03671400	SPACER BUSH	1	
13	01560900	SUPPORT TENSION REGULATOR	1	
14	50096200	HEXAGON SCREW	1	
15	02270800	TENS. REGULATOR 12V	1	
16	50148100	WASHER, FLAT	3	
17	50183000	ALLEN SCREW	2	
18	50327300	ALLEN SCREW	6	
19	04193600	BLOWER RING	1	
20	50416800	ALLEN SCREW	3	
21	50003400	WASHER, LOCK	6	
22	04098720	FLANGE	1	
23	50035200	PIN	3	
24	04110120	ADD. FLYWHEEL	1	
26	01925900	ALTERNATOR ASSY. 12V 200W	1	INCLUDES ITEMS W/\$
27\$		INDUCTOR RING, ALTERNATOR.....	1	NOT SOLD SEPARATELY
28\$		STATOR	1	NOT SOLD SEPARATELY
29	50081900	WASHER, LOCK	4	
30	50547000	ALLEN SCREW	4	
31	50081200	WASHER, LOCK	5	
32	50448700	ALLEN SCREW	5	
34	50358400	STRAP	3	
35	04108000	GEAR RING	1	
37	04138400	SUPPORT	1	
38	50114300	DISC	5	
39	50402100	PLUG SLEEVE HOUSING	1	

HATZ 1B30 ENGINE — SPEED CONTROL ASSY.

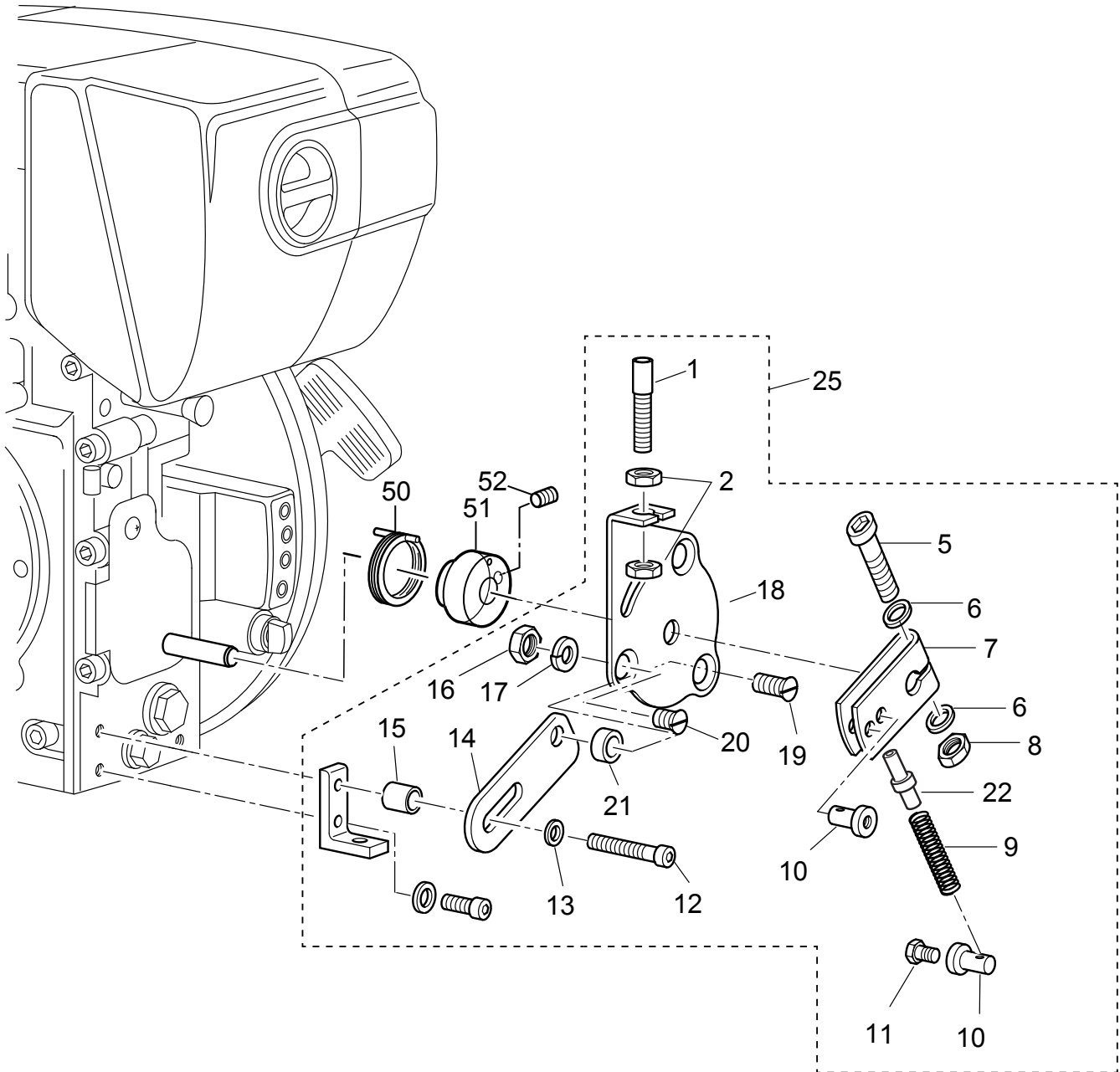

HATZ 1B30 ENGINE — SPEED CONTROL ASSY.

<u>NO.</u>	<u>PART NO.</u>	<u>PART NAME</u>	<u>QTY.</u>	<u>REMARKS</u>
1\$	05141200	ADJUSTING SCREW	1	
2\$	50144400	HEXAGON NUT	2	
5\$	50511900	ALLEN SCREW	1	
6\$	50216300	WASHER	2	
7\$	05117700	LEVER	1	
8\$	50094300	HEXAGON NUT	1	
9\$	50483200	PRESSURE SPRING	1	
10\$	50483100	CABLE CLAMPING	2	
11\$	50025000	HEXAGON SCREW	1	
12\$	50248800	ALLEN SCREW	1	
13\$	50148100	WASHER, FLAT	1	
14\$	05117500	PLATE	1	
15\$	03520600	SPACER TUBE	1	
16\$	50328300	HEXAGON NUT	1	
17\$	50208500	WASHER, LOCK	1	
18\$	05117610	CONSOLE	1	
19\$	50423900	COUNTERSUNK SCREW	1	
20\$	50380800	COUNTERSUNK SCREW	1	
21\$	03292900	SPACER TUBE	1	
22\$	05165000	GUIDE BUSH	1	
25	01563502	SPEED CONTROL	1	INCLUDES ITEMS W/\$
50	05154010	SPRING	1	
51	05179000	BUSH	1	
52	50400600	GRUB SCREW	1	

HATZ 1B30 ENGINE — SPEC. EQUIPMENT EPA ASSY.

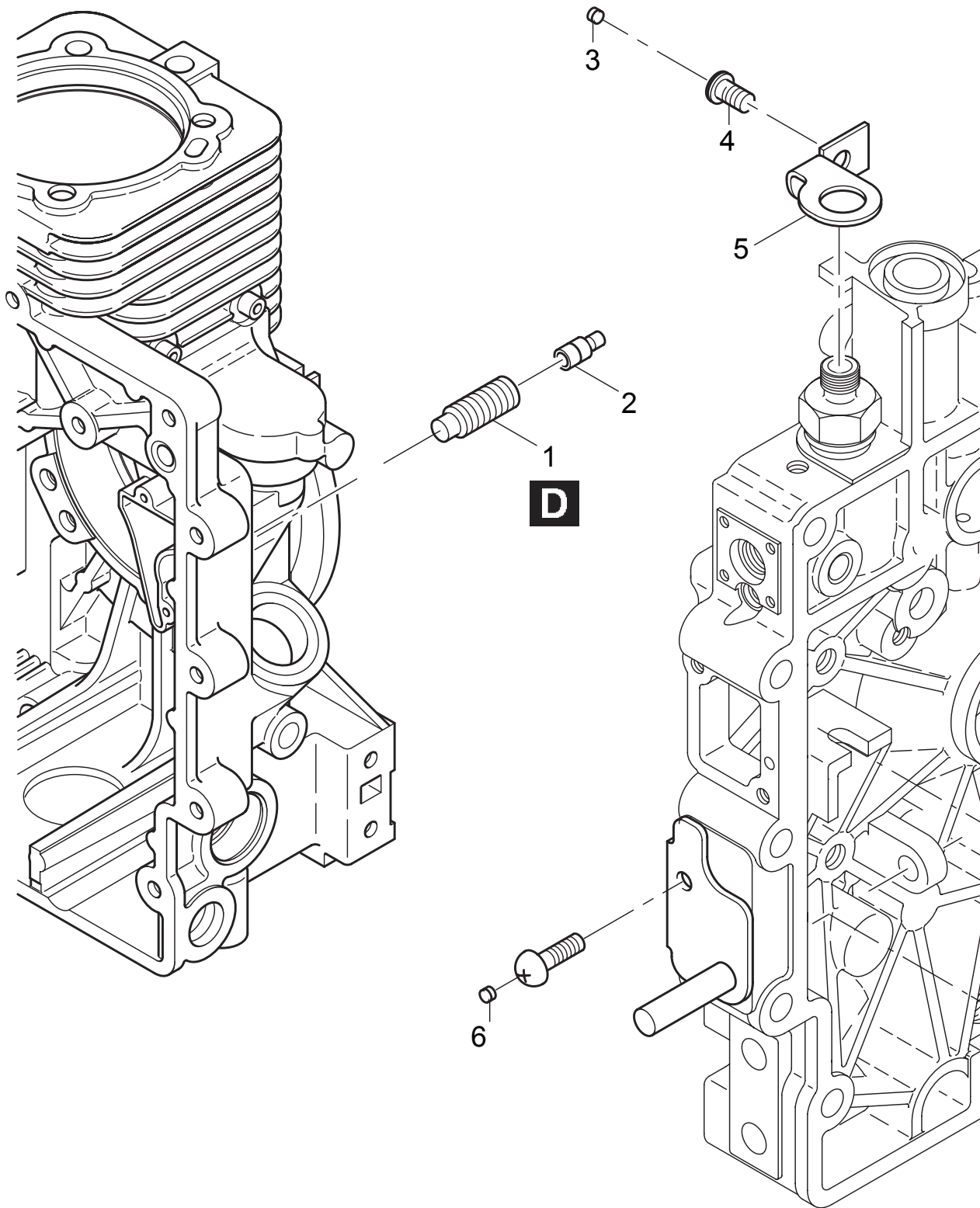

HATZ 1B30 ENGINE — SPEC. EQUIPMENT EPA ASSY.

<u>NO.</u>	<u>PART NO.</u>	<u>PART NAME</u>	<u>QTY.</u>	<u>REMARKS</u>
D	70018918	LOCTITE 243, 50ML	1	
1	04198700	GRUB SCREW CARB/EPA	1	
2	04150500	CLOSING PLUG 6 CARB.	1	
3	04170600	PLUG	1	
4	50495000	SCREW	1	
5	04185301	GUARD	1	
6	05201500	CLOSING PLUG	1	

HATZ 1B30 ENGINE — ELECTRIC EQUIPMENT, WIRING ASSY.

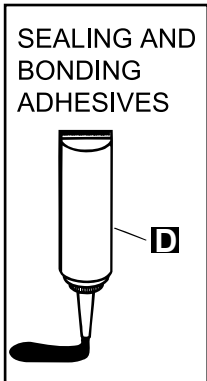
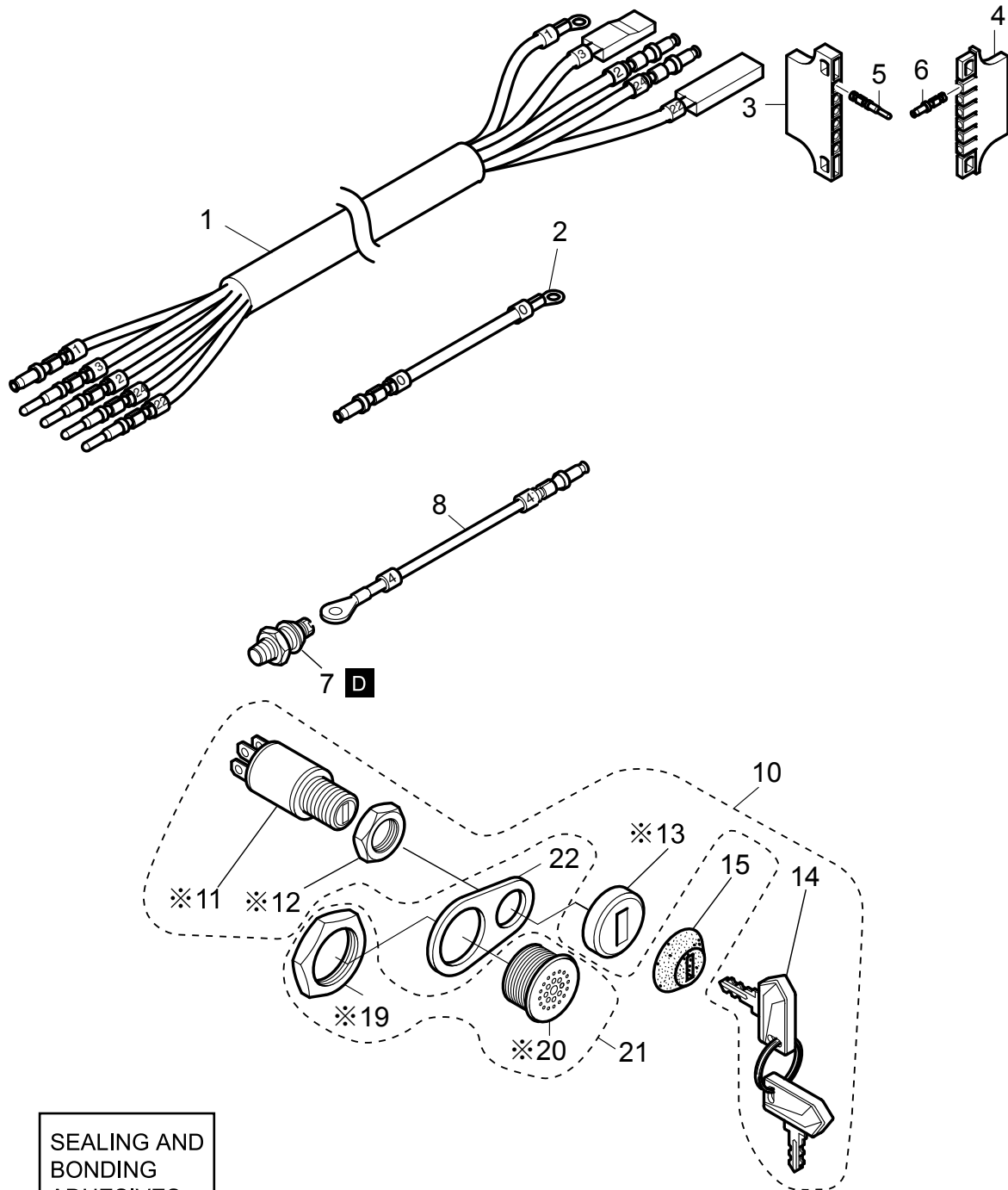

※ NOT SOLD SEPARATELY

HATZ 1B30 ENGINE — ELECTRIC EQUIPMENT, WIRING ASSY.

<u>NO.</u>	<u>PART NO.</u>	<u>PART NAME</u>	<u>QTY.</u>	<u>REMARKS</u>
1	01542200	WIRING HARNESS	1	
2	01548300	ELECTRIC WIRE 220MM	1	
3	50373600	PIN TERMINAL HOUSING 6-WAY	1	
4	50373700	PLUG SLEEVE HOUSING	1	
5	50374100	PIN TERMINAL	5	
6	50373900	SLEEVE	6	
7	50469101	OIL PRESSURE SWITCH	1	
8	01548000	ELECTRIC WIRE	1	
10	50384401	SWITCH, KEY ASSY.	1	
14	50404900	IGNITION SWITCH KEY	1	
15	05126402	PROTECTION CAP	1	
21	50465100	BUZZER 12/24V.	1	
22	05131801	FASTENING PLATE	1	

TERMS AND CONDITIONS OF SALE — PARTS

PAYMENT TERMS

Terms of payment for parts are net 30 days.

FREIGHT POLICY

All parts orders will be shipped collect or prepaid with the charges added to the invoice. All shipments are F.O.B. point of origin. Multiquip's responsibility ceases when a signed manifest has been obtained from the carrier, and any claim for shortage or damage must be settled between the consignee and the carrier.

MINIMUM ORDER

The minimum charge for orders from Multiquip is \$15.00 net. Customers will be asked for instructions regarding handling of orders not meeting this requirement.

RETURNED GOODS POLICY

Return shipments will be accepted and credit will be allowed, subject to the following provisions:

1. A Returned Material Authorization must be approved by Multiquip prior to shipment.
2. To obtain a Return Material Authorization, a list must be provided to Multiquip Parts Sales that defines item numbers, quantities, and descriptions of the items to be returned.
 - a. The parts numbers and descriptions must match the current parts price list.
 - b. The list must be typed or computer generated.
 - c. The list must state the reason(s) for the return.
 - d. The list must reference the sales order(s) or invoice(s) under which the items were originally purchased.
 - e. The list must include the name and phone number of the person requesting the RMA.
3. A copy of the Return Material Authorization must accompany the return shipment.
4. Freight is at the sender's expense. All parts must be returned freight prepaid to Multiquip's designated receiving point.

5. Parts must be in new and resalable condition, in the original Multiquip package (if any), and with Multiquip part numbers clearly marked.
6. The following items are not returnable:
 - a. Obsolete parts. (If an item is in the price book and shows as being replaced by another item, it is obsolete.)
 - b. Any parts with a limited shelf life (such as gaskets, seals, "O" rings, and other rubber parts) that were purchased more than six months prior to the return date.
 - c. Any line item with an extended dealer net price of less than \$5.00.
 - d. Special order items.
 - e. Electrical components.
 - f. Paint, chemicals, and lubricants.
 - g. Decals and paper products.
 - h. Items purchased in kits.
7. The sender will be notified of any material received that is not acceptable.
8. Such material will be held for five working days from notification, pending instructions. If a reply is not received within five days, the material will be returned to the sender at his expense.
9. Credit on returned parts will be issued at dealer net price at time of the original purchase, less a 15% restocking charge.
10. In cases where an item is accepted, for which the original purchase document can not be determined, the price will be based on the list price that was effective twelve months prior to the RMA date.
11. Credit issued will be applied to future purchases only.

PRICING AND REBATES

Prices are subject to change without prior notice. Price changes are effective on a specific date and all orders received on or after that date will be billed at the revised price. Rebates for price declines and added charges for price increases will not be made for stock on hand at the time of any price change.

Multiquip reserves the right to quote and sell direct to Government agencies, and to Original Equipment Manufacturer accounts who use our products as integral parts of their own products.

SPECIAL EXPEDITING SERVICE

A \$35.00 surcharge will be added to the invoice for special handling including bus shipments, insured parcel post or in cases where Multiquip must personally deliver the parts to the carrier.

LIMITATIONS OF SELLER'S LIABILITY

Multiquip shall not be liable hereunder for damages in excess of the purchase price of the item with respect to which damages are claimed, and in no event shall Multiquip be liable for loss of profit or good will or for any other special, consequential or incidental damages.

LIMITATION OF WARRANTIES

No warranties, express or implied, are made in connection with the sale of parts or trade accessories nor as to any engine not manufactured by Multiquip. Such warranties made in connection with the sale of new, complete units are made exclusively by a statement of warranty packaged with such units, and Multiquip neither assumes nor authorizes any person to assume for it any other obligation or liability whatever in connection with the sale of its products. Apart from such written statement of warranty, there are no warranties, express, implied or statutory, which extend beyond the description of the products on the face hereof.

Effective: February 22, 2006

OPERATION AND PARTS MANUAL

HERE'S HOW TO GET HELP

PLEASE HAVE THE MODEL AND SERIAL
NUMBER ON-HAND WHEN CALLING

UNITED STATES

Multiquip Corporate Office

18910 Wilmington Ave.
Carson, CA 90746
Contact: mq@multiquip.com

Tel. (800) 421-1244
Fax (310) 537-3927

Service Department

800-421-1244
310-537-3700

Fax: 310-537-4259

Technical Assistance

800-478-1244

Fax: 310-943-2238

MQ Parts Department

800-427-1244
310-537-3700

Fax: 800-672-7877
Fax: 310-637-3284

Warranty Department

800-421-1244
310-537-3700

Fax: 310-943-2249

CANADA

Multiquip

4110 Industriel Boul.
Laval, Quebec, Canada H7L 6V3
Contact: infocanda@multiquip.com

Tel: (450) 625-2244
Tel: (877) 963-4411
Fax: (450) 625-8664

UNITED KINGDOM

Multiquip (UK) Limited Head Office

Unit 2, Northpoint Industrial Estate,
Globe Lane,
Dukinfield, Cheshire SK16 4UJ
Contact: sales@multiquip.co.uk

Tel: 0161 339 2223
Fax: 0161 339 3226

© COPYRIGHT 2016, MULTIQUIP INC.

Multiquip Inc, the MQ logo and the Mikasa logo are registered trademarks of Multiquip Inc. and may not be used, reproduced, or altered without written permission. All other trademarks are the property of their respective owners and used with permission.

This manual MUST accompany the equipment at all times. This manual is considered a permanent part of the equipment and should remain with the unit if resold.

The information and specifications included in this publication were in effect at the time of approval for printing. Illustrations, descriptions, references and technical data contained in this manual are for guidance only and may not be considered as binding. Multiquip Inc. reserves the right to discontinue or change specifications, design or the information published in this publication at any time without notice and without incurring any obligations.

Your Local Dealer is:

