

# OPERATION AND PARTS MANUAL



*Mikasa* SERIES  
**MODEL MVH208GH**  
**REVERSIBLE PLATE COMPACTOR**  
**(HONDA GX240UT2SMXC GASOLINE ENGINE)**

Revision #1 (07/29/16)

To find the latest revision of this  
publication, visit our website at:  
[www.multiquip.com](http://www.multiquip.com)



**THIS MANUAL MUST ACCOMPANY THE EQUIPMENT AT ALL TIMES.**



**CALIFORNIA — Proposition 65 Warning**

Gasoline engine exhaust and some of its constituents are known to the State of California to cause cancer, birth defects and other reproductive harm.



# TABLE OF CONTENTS

## MVH208GH Reversible Plate Compactor

Proposition 65 Warning .....	2
Table Of Contents .....	4
Parts Ordering Procedures.....	5
Safety Information .....	6-10
Specifications .....	11
Dimensions.....	12
General Information.....	13
Components .....	14-15
Basic Engine.....	16
Inspection .....	17-18
Startup.....	19-20
Operation.....	21-22
Maintenance .....	23-29
Troubleshooting (Compactor) .....	30
Troubleshooting (Engine).....	31-32
Explanation Of Code In Remarks Column.....	34
Suggested Spare Parts .....	35

## Component Drawings

Vibrating Plate Assembly.....	36-37
Vibrator Assembly .....	38-39
Base And Engine Assembly .....	40-43
Electrical Device Assembly .....	44-45
Control Assembly .....	46-49
Nameplate And Decals Assembly .....	50-51

## Honda GX240UT2SMXC Engine

Cylinder Head Assembly .....	52-53
Cylinder Barrel Assembly .....	54-55
Crankcase Cover Assembly .....	56-57
Crankshaft Assembly.....	58-59
Piston Assembly .....	60-61
Camshaft Assembly.....	62-63
Recoil Starter Assembly .....	64-65
Fan Cover Assembly.....	66-67
Carburetor Assembly .....	68-69
Air Cleaner Assembly .....	70-71
Muffler Assembly .....	72-73
Fuel Tank Assembly.....	74-75
Flywheel Assembly .....	76-77
Ignition Coil Assembly .....	78-79
Control Assembly .....	80-81
Labels Assembly .....	82-83

Terms And Conditions Of Sale — Parts .....	84
--	----

### NOTICE

Specifications and part numbers are subject to change without notice.

# PARTS ORDERING PROCEDURES

## Ordering parts has never been easier! Choose from three easy options:

Effective:  
January 1<sup>st</sup>, 2006

www.multiquip.com



### Order via Internet (Dealers Only):

Order parts on-line using Multiquip's SmartEquip website!

- View Parts Diagrams
- Order Parts
- Print Specification Information



If you have an MQ Account, to obtain a Username and Password, E-mail us at: [parts@multiquip.com](mailto:parts@multiquip.com).

To obtain an MQ Account, contact your District Sales Manager for more information.

Goto [www.multiquip.com](http://www.multiquip.com) and click on **Order Parts** to log in and save!

Use the **internet** and qualify for a **5% Discount** on *Standard orders* for all orders which include complete part numbers.\*

Note: Discounts Are Subject To Change

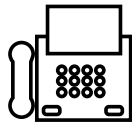

### Order via Fax (Dealers Only):

All customers are welcome to order parts via Fax.

**Domestic (US) Customers dial:**  
1-800-6-PARTS-7 (800-672-7877)

**Fax** your order in and qualify for a **2% Discount** on *Standard orders* for all orders which include complete part numbers.\*

Note: Discounts Are Subject To Change



**Order via Phone: Domestic (US) Dealers Call:**  
1-800-427-1244

### Non-Dealer Customers:

Contact your local Multiquip Dealer for parts or call 800-427-1244 for help in locating a dealer near you.



**International Customers** should contact their local Multiquip Representatives for Parts Ordering information.

## When ordering parts, please supply:

- |   |  |
|---|--|
| <input type="checkbox"/> Dealer Account Number                                | <input type="checkbox"/> Specify Preferred Method of Shipment:                         |
| <input type="checkbox"/> Dealer Name and Address                              | <input checked="" type="checkbox"/> UPS/Fed Ex <input checked="" type="checkbox"/> DHL |
| <input type="checkbox"/> Shipping Address (if different than billing address) | <input type="checkbox"/> Priority One <input checked="" type="checkbox"/> Truck        |
| <input type="checkbox"/> Return Fax Number                                    | <input type="checkbox"/> Ground  |
| <input type="checkbox"/> Applicable Model Number                              | <input type="checkbox"/> Next Day  |
| <input type="checkbox"/> Quantity, Part Number and Description of Each Part   | <input type="checkbox"/> Second/Third Day  |

### NOTICE

All orders are treated as *Standard Orders* and will ship the same day if received prior to 3PM PST.

WE ACCEPT ALL MAJOR CREDIT CARDS!



# SAFETY INFORMATION

Do not operate or service the equipment before reading the entire manual. Safety precautions should be followed at all times when operating this equipment. Failure to read and understand the safety messages and operating instructions could result in injury to yourself and others.



## SAFETY MESSAGES

The four safety messages shown below will inform you about potential hazards that could injure you or others. The safety messages specifically address the level of exposure to the operator and are preceded by one of four words: **DANGER**, **WARNING**, **CAUTION** or **NOTICE**.

## SAFETY SYMBOLS

**! DANGER**

Indicates a hazardous situation which, if not avoided, **WILL** result in **DEATH** or **SERIOUS INJURY**.

**! WARNING**

Indicates a hazardous situation which, if not avoided, **COULD** result in **DEATH** or **SERIOUS INJURY**.

**! CAUTION**

Indicates a hazardous situation which, if not avoided, **COULD** result in **MINOR** or **MODERATE INJURY**.

**NOTICE**

Addresses practices not related to personal injury.

Potential hazards associated with the operation of this equipment will be referenced with hazard symbols which may appear throughout this manual in conjunction with safety messages.

Symbol	Safety Hazard
	Lethal exhaust gas hazards
	Explosive fuel hazards
	Burn hazards
	Respiratory hazards
	Accidental starting hazards
	Eye and hearing hazards
	Rotating parts hazards

# SAFETY INFORMATION

## GENERAL SAFETY

### CAUTION

- **NEVER** operate this equipment without proper protective clothing, shatterproof glasses, respiratory protection, hearing protection, steel-toed boots and other protective devices required by the job or city and state regulations.



- **NEVER** operate this equipment when not feeling well due to fatigue, illness or when under medication.



- **NEVER** operate this equipment under the influence of drugs or alcohol.



- **ALWAYS** check the equipment for loosened threads or bolts before starting.
- **DO NOT** use the equipment for any purpose other than its intended purposes or applications.
- **ALWAYS** clear the work area of any debris, tools, etc. that would constitute a hazard while the equipment is in operation.

### NOTICE

- This equipment should only be operated by trained and qualified personnel 18 years of age and older.
- Whenever necessary, replace nameplate, operation and safety decals when they become difficult read.
- Manufacturer does not assume responsibility for any accident due to equipment modifications. Unauthorized equipment modification will void all warranties.
- **NEVER** use accessories or attachments that are not recommended by Multiquip for this equipment. Damage to the equipment and/or injury to user may result.
- **ALWAYS** know the location of the nearest **fire extinguisher**.
- **ALWAYS** know the location of the nearest **first aid kit**.
- **ALWAYS** know the location of the nearest phone or **keep a phone on the job site**. Also, know the phone numbers of the nearest **ambulance**, **doctor** and **fire department**. This information will be invaluable in the case of an emergency.



# SAFETY INFORMATION

## COMPACTOR SAFETY

### DANGER

- **NEVER** operate the equipment in an explosive atmosphere or near combustible materials. An explosion or fire could result causing severe **bodily harm or even death.**



### WARNING

- **NEVER** disconnect any **emergency or safety devices.** These devices are intended for operator safety. Disconnection of these devices can cause severe injury, bodily harm or even death. Disconnection of any of these devices will void all warranties.

### CAUTION

- **NEVER** lubricate components or attempt service on a running machine.

### NOTICE

- **ALWAYS** keep the machine in proper running condition.
- Fix damage to machine and replace any broken parts immediately.
- **ALWAYS** store equipment properly when it is not being used. Equipment should be stored in a clean, dry location out of the reach of children and unauthorized personnel.

## ENGINE SAFETY

### DANGER

- The engine fuel exhaust gases contain poisonous carbon monoxide. This gas is colorless and odorless, and can cause death if inhaled.
- The engine of this equipment requires an adequate free flow of cooling air. **NEVER** operate this equipment in any enclosed or narrow area where free flow of the air is restricted. If the air flow is restricted it will cause injury to people and property and serious damage to the equipment or engine.



### WARNING

- **DO NOT** place hands or fingers inside engine compartment when engine is running.
- **NEVER** operate the engine with heat shields or guards removed.
- Keep fingers, hands hair and clothing away from all moving parts to prevent injury.
- **DO NOT** remove the radiator cap while the engine is hot. High pressure boiling water will gush out of the radiator and severely scald any persons in the general area of the compactor.
- **DO NOT** remove the coolant drain plug while the engine is hot. Hot coolant will gush out of the coolant tank and severely scald any persons in the general area of the compactor.
- **DO NOT** remove the engine oil drain plug while the engine is hot. Hot oil will gush out of the oil tank and severely scald any persons in the general area of the compactor.



### CAUTION

- **NEVER** touch the hot exhaust manifold, muffler or cylinder. Allow these parts to cool before servicing equipment.



### NOTICE

- **NEVER** run engine without an air filter or with a dirty air filter. Severe engine damage may occur. Service air filter frequently to prevent engine malfunction.
- **NEVER** tamper with the factory settings of the engine or engine governor. Damage to the engine or equipment can result if operating in speed ranges above the maximum allowable.
- **NEVER** tip the engine to extreme angles during lifting as it may cause oil to gravitate into the cylinder head, making the engine start difficult.







# SAFETY INFORMATION

## FUEL SAFETY

### DANGER

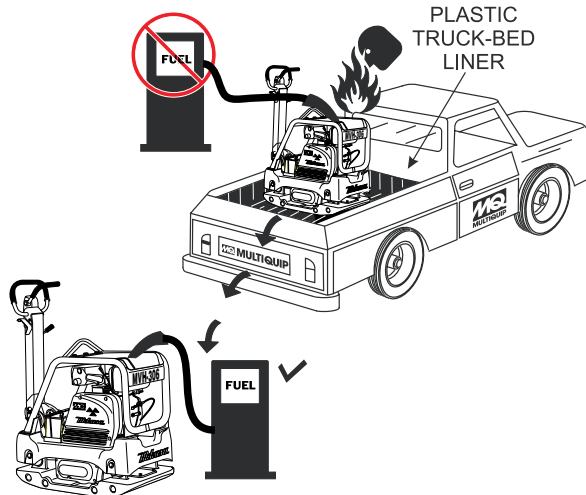
- **DO NOT** add fuel to equipment if it is placed inside truck bed with plastic liner. Possibility exists of explosion or fire due to static electricity.



- **DO NOT** start the engine near spilled fuel or combustible fluids. Diesel fuel is extremely flammable and its vapors can cause an explosion if ignited.
- **ALWAYS** refuel in a well-ventilated area, away from sparks and open flames.
- **ALWAYS** use extreme caution when working with **flammable** liquids.
- **DO NOT** fill the fuel tank while the engine is running or hot.
- **DO NOT** overfill tank, since spilled fuel could ignite if it comes into contact with hot engine parts or sparks from the ignition system.
- Store fuel in appropriate containers, in well-ventilated areas and away from sparks and flames.
- **NEVER** use fuel as a cleaning agent.
- **DO NOT** smoke around or near the equipment. Fire or explosion could result from fuel vapors or if fuel is spilled on a hot engine. 

## BATTERY SAFETY (ELECTRIC START ONLY)

### DANGER

- **DO NOT** drop the battery. There is a possibility that the battery will explode.
- **DO NOT** expose the battery to open flames, sparks, cigarettes, etc. The battery contains combustible gases and liquids. If these gases and liquids come into contact with a flame or spark, an explosion could occur. 

### WARNING

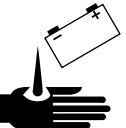
- **ALWAYS** wear safety glasses when handling the battery to avoid eye irritation. The battery contains acids that can cause injury to the eyes and skin. 
- Use well-insulated gloves when picking up the battery.
- **ALWAYS** keep the battery charged. If the battery is not charged, combustible gas will build up.
- **DO NOT** charge battery if frozen. Battery can explode. When frozen, warm the battery to at least 61°F (16°C).
- **ALWAYS** recharge the battery in a well-ventilated environment to avoid the risk of a dangerous concentration of combustible gases.
- If the battery liquid (dilute sulfuric acid) comes into contact with **clothing or skin**, rinse skin or clothing immediately with plenty of water. 
- If the battery liquid (dilute sulfuric acid) comes into contact with **eyes**, rinse eyes immediately with plenty of water and contact the nearest doctor or hospital to seek medical attention.

### CAUTION

- **ALWAYS** disconnect the **NEGATIVE** battery terminal before performing service on the equipment.
- **ALWAYS** keep battery cables in good working condition. Repair or replace all worn cables.

# SAFETY INFORMATION

## TRANSPORTING SAFETY

### CAUTION

- NEVER allow any person or animal to stand underneath the equipment while lifting.

### NOTICE

- Before lifting, make sure that the equipment parts (hook and vibration insulator) are not damaged and screws are not loose or missing.
- Always make sure crane or lifting device has been properly secured to the lifting bail (hook) of the equipment.
- **ALWAYS** shutdown engine before transporting.
- **NEVER** lift the equipment while the engine is running.
- Tighten fuel tank cap securely and close fuel cock to prevent fuel from spilling.
- Use adequate lifting cable (wire or rope) of sufficient strength.
- Use one point suspension hook and lift straight upwards.
- **DO NOT** lift machine to unnecessary heights.
- **ALWAYS** tie down equipment during transport by securing the equipment with rope.

## ENVIRONMENTAL SAFETY/DECOMMISSIONING

### NOTICE

Decommissioning is a controlled process used to safely retire a piece of equipment that is no longer serviceable. If the equipment poses an unacceptable and unrepairable safety risk due to wear or damage or is no longer cost effective to maintain (beyond life-cycle reliability) and is to be decommissioned (demolition and dismantlement), be sure to follow rules below:

- **DO NOT** pour waste or oil directly onto the ground, down a drain or into any water source.
- Contact your country's Department of Public Works or recycling agency in your area and arrange for proper disposal of any electrical components, waste or oil associated with this equipment.



- When the life cycle of this equipment is over, remove battery and bring to appropriate facility for lead reclamation. Use safety precautions when handling batteries that contain sulfuric acid.

- When the life cycle of this equipment is over, it is recommended that the trowel frame and all other metal parts be sent to a recycling center.

Metal recycling involves the collection of metal from discarded products and its transformation into raw materials to use in manufacturing a new product.

Recyclers and manufacturers alike promote the process of recycling metal. Using a metal recycling center promotes energy cost savings.

## EMISSIONS INFORMATION

### NOTICE

The diesel engine used in this equipment has been designed to reduce harmful levels of carbon monoxide (CO), hydrocarbons (HC) and nitrogen oxides (NOx) contained in diesel exhaust emissions.

This engine has been certified to meet US EPA Evaporative emissions requirements in the installed configuration.

Attempting to modify or make adjustments to the engine emission system by unauthorized personnel without proper training could damage the equipment or create an unsafe condition.

Additionally, modifying the fuel system may adversely affect evaporative emissions, resulting in fines or other penalties.

### Emission Control Label

The emission control label is an integral part of the emission system and is strictly controlled by regulations.

The label must remain with the engine for its entire life.

If a replacement emission label is needed, please contact your authorized Kohler Engine Distributor.

# SPECIFICATIONS

<b>Table 1. MVH208GH Specifications</b>	
Centrifugal Force	8,317.93 lbf (37 kN)
Vibration Frequency	5,200 vpm (87 Hz)
Maximum Traveling Speed	85 ft/min (26 m/min)
Plate Size (W x L)	19.7 x 28.3 in (500 x 720 mm)
Operating Weight	463 lbs. (210 kg.)

<b>Table 2. Engine Specifications</b>	
Engine Make	HONDA
Engine Model	GX240UT2SMXC
Engine Type	Air-cooled, 4 stroke Gasoline Engine
Cylinder Bore X Stroke	3.03 in. x 2.28 in. (77 mm x 58 mm)
Displacement	16.48 cu-in (270 cc)
Maximum Output	7.1 HP (5.3 kW) @ 3600 RPM
Fuel Tank Capacity	Approx. 1.4 U.S. gallons (5.3 liters)
Fuel Type	Unleaded 86 Octane or Higher
Oil Capacity	1.16 qts (1.1 liters)
Starting Method	Recoil Start
Dry Net Weight Recoil/Electric	56.88 lbs (25.8 Kg.)
Dimensions (L x W x H)	15 x 16.85 x 16.61 in (381 x 428 x 422 mm)

# DIMENSIONS

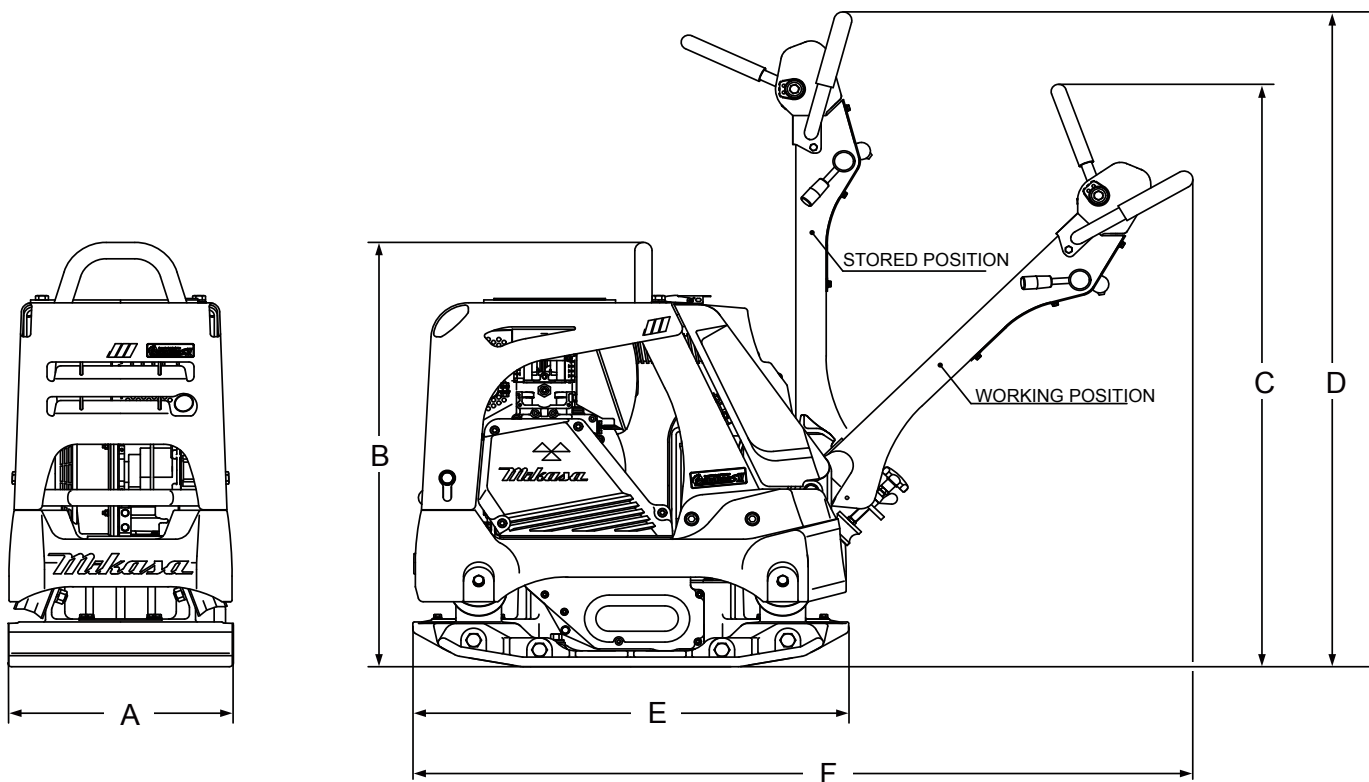

**Figure 1. Dimensions**

Table 3. Dimensions	
REF. DES	IN. (MM)
A	19.68 (500)
B	32.75 (832)
C	39.2 (995)
D	48.4 (1230)
E	28.35 (720)
F	51.57 (1310)

## **GENERAL INFORMATION**

---

### **DEFINITION OF PLATE COMPACTOR**

The Mikasa MVH208GH is a reversible plate compactor designed for efficient compaction of sand, gravel and cohesive soils. This plate compactor is a powerful compacting tool capable of applying a tremendous force in consecutive high frequency vibrations to a soil surface. Its applications include compacting for road, embankments and reservoirs as well as backfilling for gas pipelines, water pipelines and cable installation work.

### **VIBRATORY PLATES**

The vibratory plates of the compactor produce low amplitude high frequency vibrations, designed to compact granular soils and asphalt.

The resulting vibrations cause forward motion. The engine and handle are vibration isolated from the vibrating plate.

### **FREQUENCY/SPEED**

The compactor's vibrating plate produces a vibration frequency of 5,200 VPM (vibrations per minute). The travel speed of the compactor is approximately 85 ft/minute (26 meters/minute).

### **ENGINE**

This plate compactor is equipped with a Honda GX240UT2SMXC air cooled, 4-cycle gasoline engine. The engine drives an eccentric weight at a high speed to develop a compaction force.

### **CONTROLS**

Before starting the plate compactor identify and understand the function of all the controls and components.

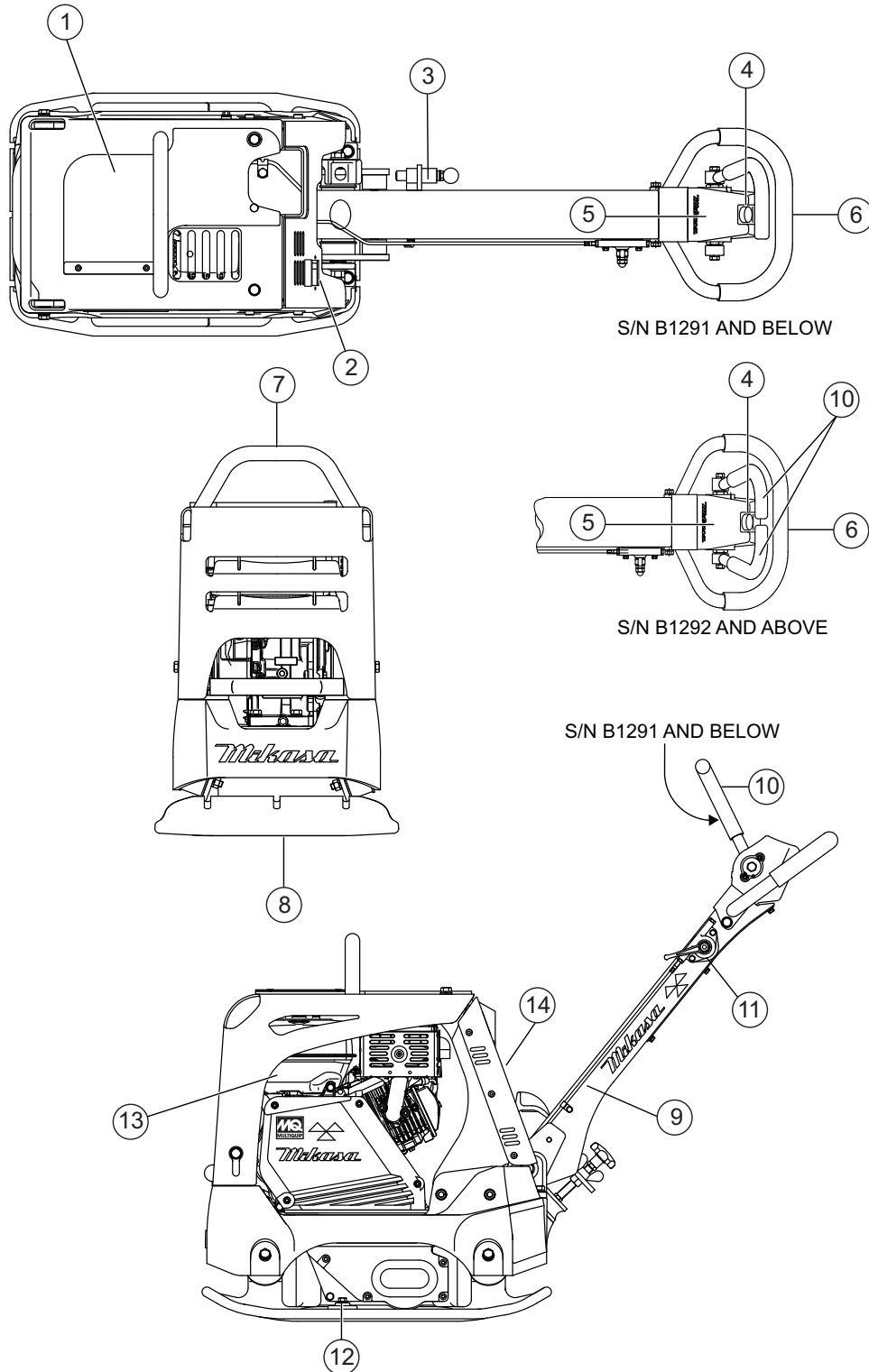

Figure 2. Plate Compactor Components

## COMPONENTS

---

Figure 2 shows the location of the basic controls and components of the MVH208GH Plate Compactor. The function of each control is described below:

1. **Rubber Cover** — Lift this rubber cover to gain access to the fuel tank.
2. **Hour/Tachometer** — Displays the cumulative time that the machine has been in use. During operation it displays the rpm reading.
3. **Handle Bar Height Adjuster** — Adjusts the handle bar to the desired height by loosening the wing nut and turning the grip clockwise to raise the handle bar and counterclockwise to lower the handle bar.
4. **Breather Plug** — Allow pressure to escape to the air in the form of a gas from heat.
5. **Hydraulic Pump (Oil Reservoir)** — Regulates hydraulic oil flow produced by the direction of the control lever.
6. **Hand Grip** — When operating the compactor use this hand grip to maneuver the compactor.
7. **Lifting Bale** — When lifting of the compactor is required either by forklift, crane etc., tie rope or chain around this lifting point.
8. **Vibrating Plate** — A flat, open plate made of durable cast iron construction used in the compacting of soil.
9. **Handle Bar** — When operating the compactor, this handle is to be in the downward position. When the compactor is to be **stored**, move the handle bar to the upright position.
10. **Direction Control Lever** — *Push* the lever forward to move compactor in a forward direction. *Pull* the lever backwards to move compactor in backwards direction. Placing the lever in the middle (midway) will cause the compactor not to move (neutral).
11. **Throttle Lever** — Controls speed of the plate compactor. Place straight vertically to start, **push** fully counterclockwise for full throttle and fully clockwise to stop plate compactor.
12. **Vibration Case Oil Filler** — Used to add oil to the vibration case.
13. **Engine**—This plate compactor uses a GX240UT2SMXC gasoline engine. Refer to the owner's manual for engine information.
14. **Engine ON-OFF Switch** — Used to turn the engine on or off.

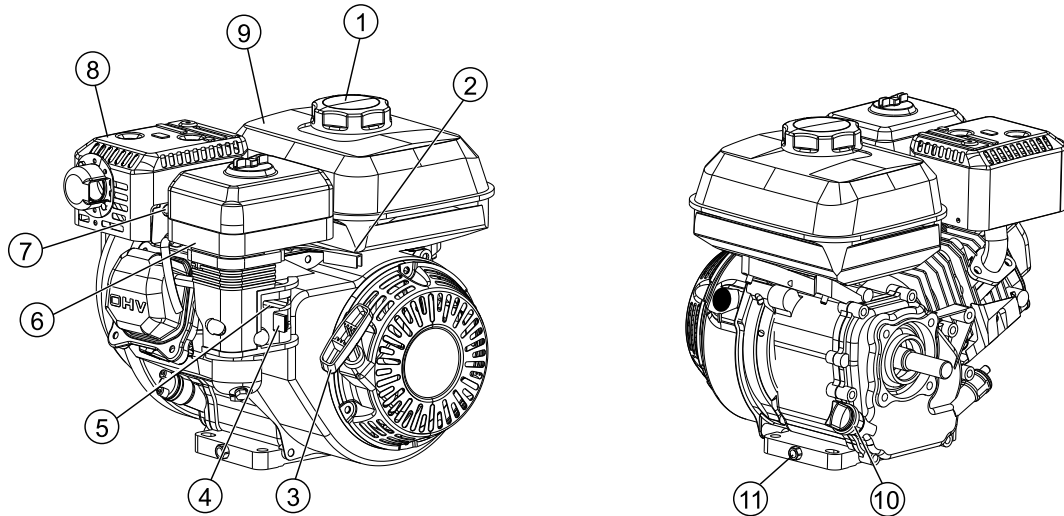

Figure 3. Engine Controls and Components

## INITIAL SERVICING

The engine (Figure 3) must be checked for proper lubrication and filled with fuel prior to operation. Refer to the manufacturer's engine manual for instructions and details of operation and servicing.

1. **Fuel Filler Cap** – Remove this cap to add unleaded gasoline to the fuel tank. Make sure cap is tightened securely. **DO NOT** over fill.

### DANGER



Add fuel to the tank only when the engine is stopped and has had an opportunity to cool down. In the event of a fuel spill, **DO NOT** attempt to start the engine until the fuel residue has been completely wiped up and the area surrounding the engine is dry.

2. **Throttle Lever** – Used to adjust engine RPM speed. For normal operation this lever should always be placed in the **RUN** position.
3. **Recoil Starter (Pull Rope)** – Manual-starting method. Pull the starter grip until resistance is felt, then pull briskly and smoothly.
4. **Fuel Valve Lever** – **OPEN** to let fuel flow, **CLOSE** to stop the flow of fuel.
5. **Choke Lever** – Used in the starting of a cold engine, or in cold weather conditions. The choke enriches the fuel mixture.

6. **Cyclone Air Cleaner** – Prevents dirt and other debris from entering the fuel system. Remove wing-nut on top of air filter canister to gain access to filter element.

### NOTICE

Operating the engine without an air filter, with a damaged air filter, or a filter in need of replacement will allow dirt to enter the engine, causing rapid engine wear.

7. **Spark Plug** – Provides spark to the ignition system. Set spark plug gap according to engine manufacturer's instructions. Clean spark plug once a week.
8. **Muffler** – Used to reduce noise and emissions. **NEVER** touch when **hot!**
9. **Fuel Tank** – Fill with unleaded gasoline. Reference Table 2 for fuel tank capacity. For additional information refer to Honda engine owner's manual.
10. **Dipstick/Oil Filler Cap** – Remove this cap to determine if the engine oil is low. Add oil through this filler port as recommended in (Table 4).
11. **Oil Drain Plug** – Remove this plug to remove oil from the engine's crankcase.



## BEFORE STARTING

1. Read all safety instructions at the beginning of manual.
2. Clean the compactor, removing dirt and dust, particularly the engine cooling air inlet, carburetor and air cleaner.
3. Check the air filter for dirt and dust. If air filter is dirty, replace air filter with a new one as required.
4. Check carburetor for external dirt and dust. Clean with dry compressed air.
5. Check fastening nuts and bolts for tightness.

## ENGINE OIL CHECK

1. To check the engine oil level, place the compactor on secure level ground with the engine stopped.
2. Remove the dipstick from the engine oil filler hole (Figure 4) and wipe clean.

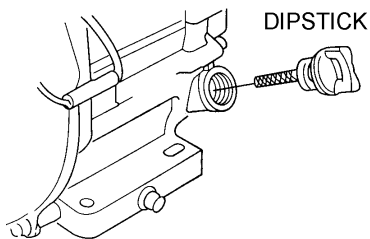

**Figure 4. Engine Oil Dipstick Removal**

3. Insert and remove the dipstick without screwing it into the filler neck. Check the oil level shown on the dipstick.
4. If the oil level is low (Figure 5), fill to the edge of the oil filler hole with the recommended oil type as listed in Table 4. Refer to Table 2 for maximum engine oil capacity.

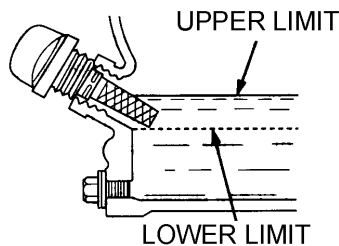

**Figure 5. Engine Oil Dipstick (Oil Level)**

**Table 4. Oil Type**

Season	Temperature	Oil Type
Summer	25°C or Higher	SAE 10W-30
Spring/Fall	25°C~10°C	SAE 10W-30/20
Winter	0°C or Lower	SAE 10W-10

## DANGER



### EXPLOSIVE FUEL!

Motor fuels are highly flammable and can be dangerous if mishandled. **DO NOT** smoke while refueling. **DO NOT** attempt to refuel the compactor if the engine is hot or running.

## FUEL CHECK

1. Visually inspect (Figure 6) to see if fuel level is low. If fuel is low, replenish with unleaded fuel.

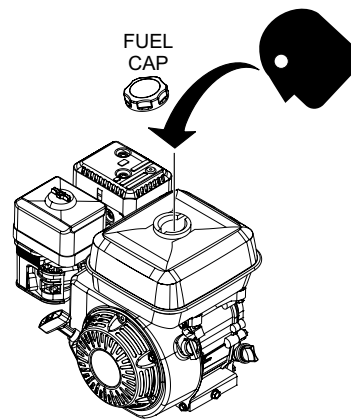
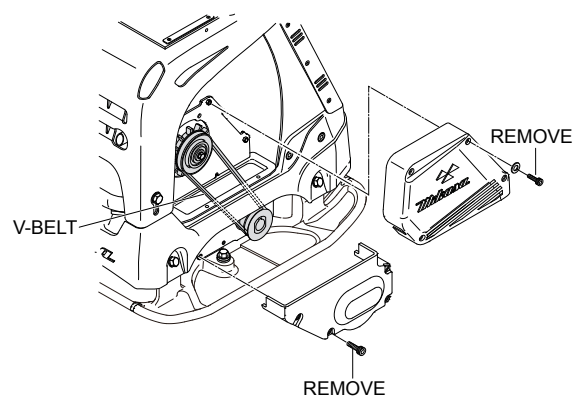

**Figure 6. Fuel Check**

2. When refueling, be sure to use a strainer for filtration. **DO NOT** top-off fuel. Wipe up any spilled fuel immediately.

## V-BELT COVER REMOVAL

To inspect the V-belt, remove the bolts that secure the belt cover to the frame as shown in Figure 7.



**Figure 7. V-Belt Cover Removal**

## V-BELT INSPECTION

Visually examine the V-belt (Figure 8) and determine if it is full of tiny cracks, frayed, has pieces of rubber missing, is peeling or otherwise damaged.

Also, examine the belt and determine if it is **oil soaked** or **"glazed"** (hard shiny appearance on the sides of the belt). Either of these two conditions can cause the belt to run hot, which can weaken it and increase the danger of it breaking.

If the V-belt exhibits any of the referenced wear conditions replace the V-belt immediately

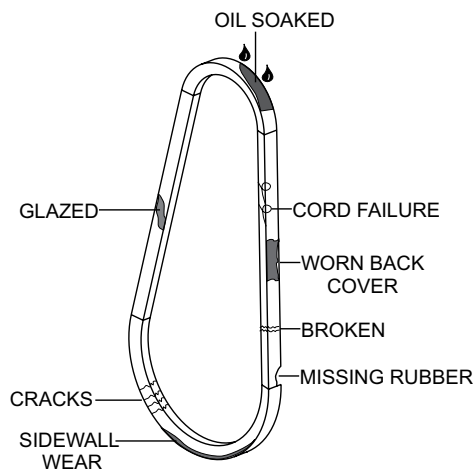

**Figure 8. Drive Belt Inspection**

## V-BELT TENSION

The V-belt tension is proper if the V-belt bends 10 to 15 mm (Figure 9) when depressed with finger at midway between the clutch and vibrator pulleys.

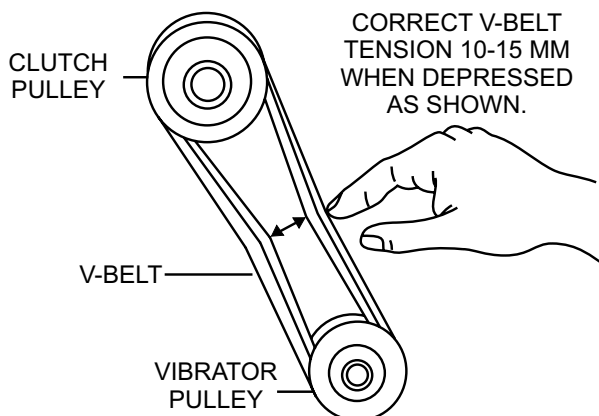

**Figure 9. V-Belt Tension**

## VIBRATOR OIL CHECK

1. Place the plate compactor horizontally on a flat surface. Make sure the compactor is level when checking the oil in the vibrator assembly.
2. Check vibrator oil level by removing the oil plug (vibrator oil gauge) as shown in Figure 10. Clean the oil gauge and re-thread back in. Remove the oil gauge again and confirm oil level does not exceed the cross hash of the oil plug. **DO NOT OVERFILL!**

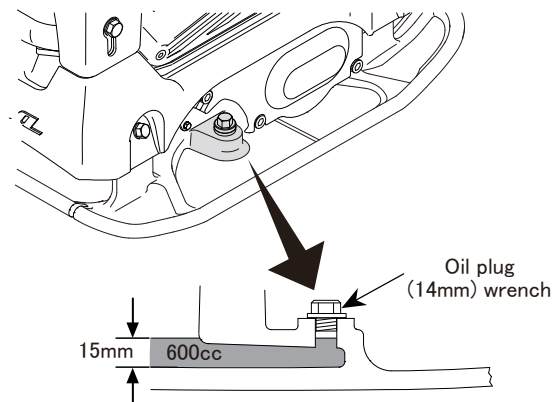

**Figure 10. Vibrator Oil Check**

3. The vibrator holds approximately 20.3 oz. (600 cc). **IMPORTANT**, if oil is required, replace using only SAE 10W-30 motor oil.

## HANDLE BAR

The height of the handle bar can be adjusted for ease of use. Adjust the handle height as follows. Refer to Figure 11.

1. Loosen the wing nut.
2. Turn the grip clockwise to raise the handle or counterclockwise to lower the handle.
3. When the handle bar is raised to the desired height, tighten the wing nut.

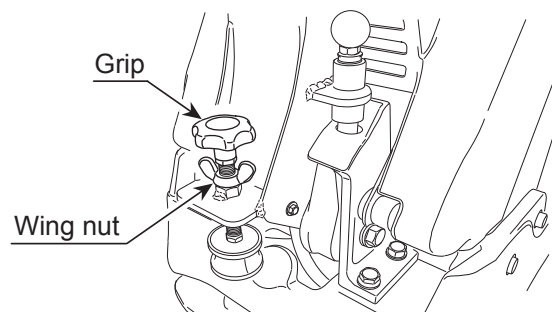

**Figure 11. Handle Height Adjustment**

## CAUTION



**DO NOT** attempt to operate the compactor until the Safety, General Information and Inspection sections of this manual have been *read and thoroughly understood*.

This section is intended to assist the operator with the initial startup of the compactor. It is extremely important that this section be read carefully before attempting to use the compactor in the field.

## STARTING THE ENGINE

1. Place the engine fuel valve lever (Figure 12) to the "ON" position.

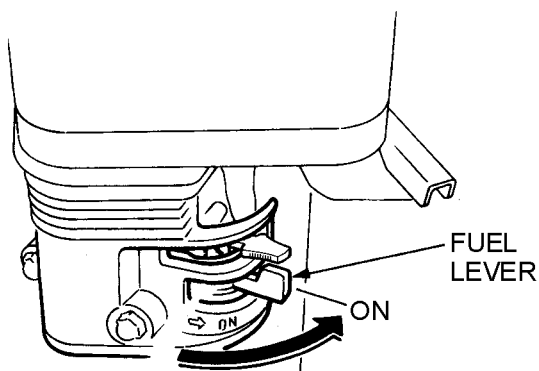

**Figure 12. Engine Fuel Valve Lever (ON Position)**

2. Move the throttle lever (Figure 13) slightly higher from the *idle* position.

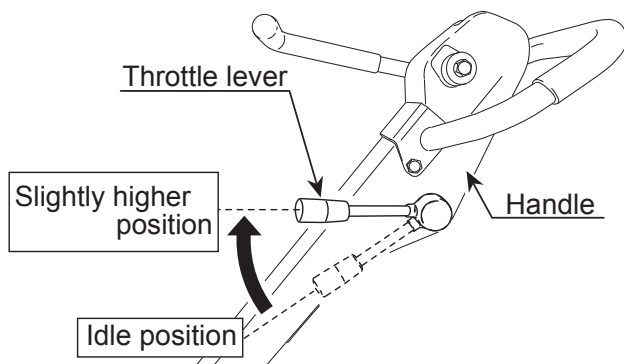

**Figure 13. Throttle Lever (Higher Position)**

3. Place the choke lever (Figure 14) in the "CLOSED" position if starting a cold engine.

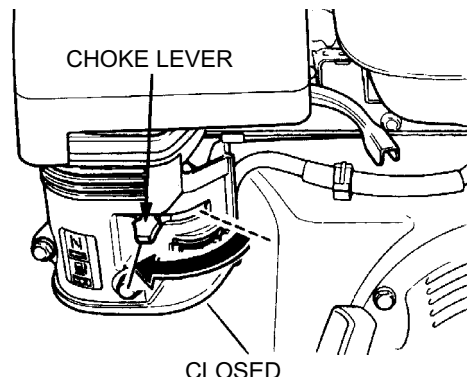
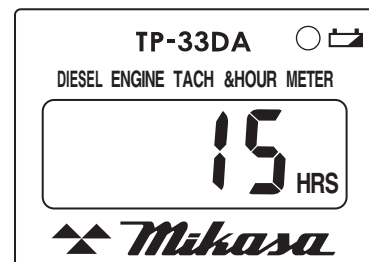

**Figure 14. Choke Lever (Closed)**

## NOTICE

The **CLOSED** position of the choke lever enriches the fuel mixture for starting a **COLD** engine. The **OPEN** position provides the correct fuel mixture for normal operation after starting, and for restarting a warm engine.

4. When the engine is stopped, the hour tachometer always shows "cumulative time" (Figure 15).



**Figure 15. Hour Tachometer (Cumulative Time)**

5. Place the engine ON/OFF switch (Figure 16) in the "ON" position.

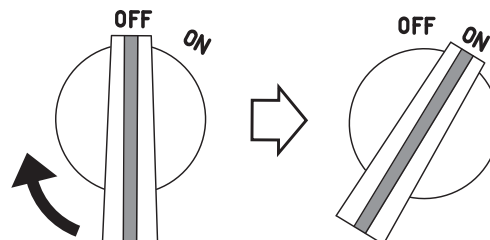

**Figure 16. Engine ON/OFF Switch (ON Position)**

6. Grasp the starter grip (Figure 17) and slowly pull it out. The resistance becomes the hardest at a certain position, corresponding the compression point. Rewind the rope a little from that point and pull out sharply.

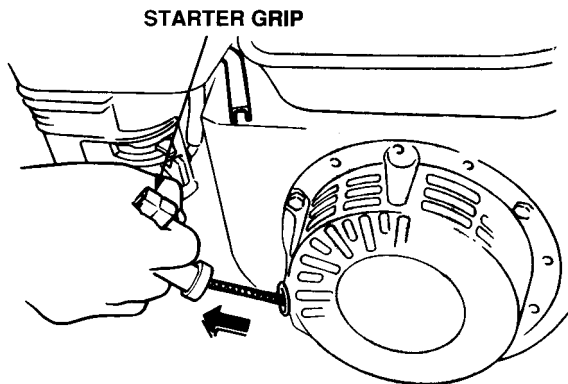

Figure 17. Starter Grip

## NOTICE

**DO NOT** pull the starter rope all the way to the end  
**DO NOT** release the starter rope after pulling. Allow it to rewind as soon as possible.

7. When engine starts, release the starter grip and allow the rope to recoil.
8. If the choke lever was moved to the "CLOSED" position to start the engine, gradually move it to the "OPEN" position (Figure 18) as the engine warms up. If the engine has not started, repeat steps 1 through 6.

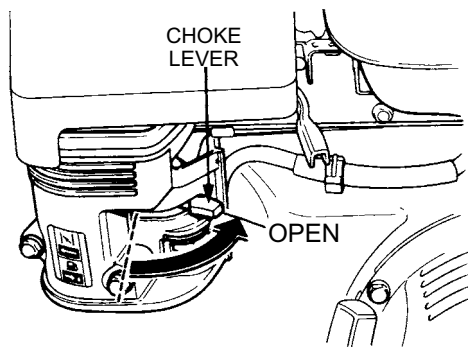

Figure 18. Choke Lever (Open)

9. Before the compactor is placed in to operation, run the engine for several minutes. Check for fuel leaks, and noises that would associate with a lose component.

10. During operation, the hour tachometer displays "rotation number" (Figure 19).

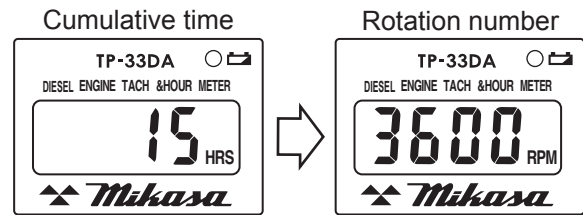

Figure 19. Hour Tachometer (Rotation Number)

## OPERATION

### CAUTION



**ALWAYS** follow all safety rules in the safety section of this manual before operating compactor. Keep work area clear of debris and other objects that could cause bodily injury or damage to the compactor.

1. Once the engine has started, move the engine throttle lever quickly to the **operation** position (Figure 20).

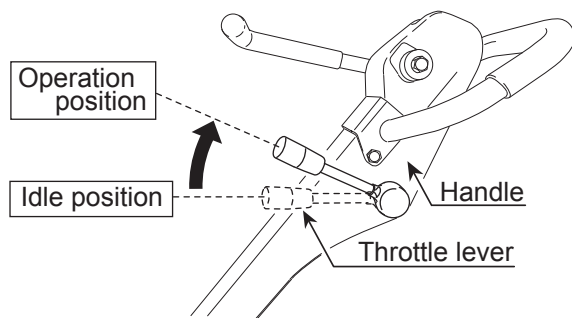

**Figure 20. Throttle Lever (Operation Position)**

2. With the throttle lever in the run position, the engine speed should be around 2,300 RPM, therefore engaging the centrifugal clutch.

### NOTICE

**ALWAYS** move the throttle lever quickly without hesitation, because increasing the engine speed slowly causes the clutch to slip.

3. The direction control lever allows the machine to be moved either backward or forward (Figure 21). When the direction control lever is pushed forward, the machine moves forward. When pulled backward, the machine moves backward.

### NOTICE

Your unit may be equipped with direction control levers on both the right and left side of the handle. Earlier models only have one control lever located on the right side of the handle.

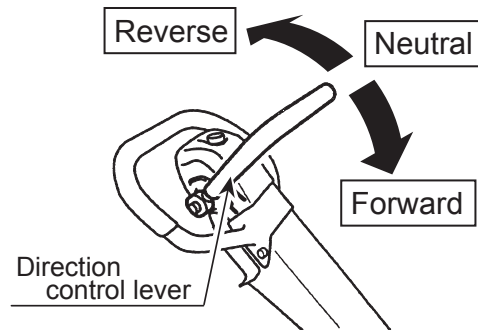

**Figure 21. Direction Control Lever**

4. When the direction control lever is the neutral position, the machine vibrates staying at the same location

### NOTICE

**NEVER** stop the engine suddenly while working at high speeds.

5. Compactor traveling speed may drop on soils which contain clay, however there may be cases where traveling speed drops because the compaction plate does not leave the ground surface easily due to the composition of the soil. To rectify this problem do the following:
  - Check the bottom plate to see if clay or equivalent material has been lodged in the plate mechanism. If so, wash with water and remove.
  - Remember the compactor does not work as efficiently on clay or soils that have a high moisture content level.
  - If the soil has a high moisture level, dry soil to appropriate moisture content level or carry out compaction twice.

## STOPPING THE ENGINE

### Normal Shutdown

1. Move the throttle lever to the **idle** position (Figure 22) and run the engine for three minutes at low speed.

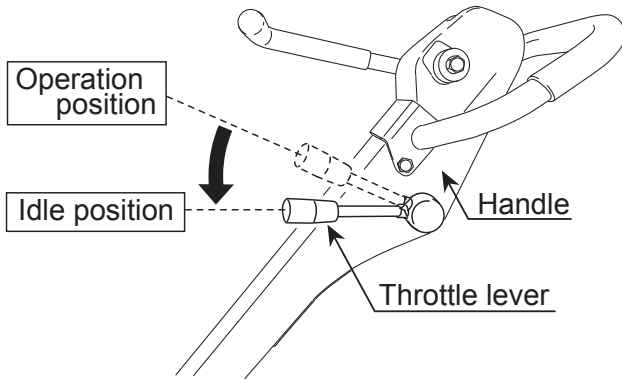

**Figure 22. Throttle Lever (Idle)**

2. Place the engine **ON/OFF** switch (Figure 23) in the **OFF** position.

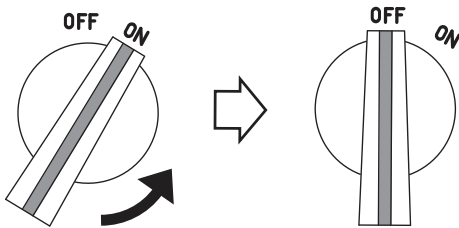

**Figure 23. Engine ON/OFF Switch (OFF Position)**

3. Place the fuel shut-off lever (Figure 24) in the **OFF** position.

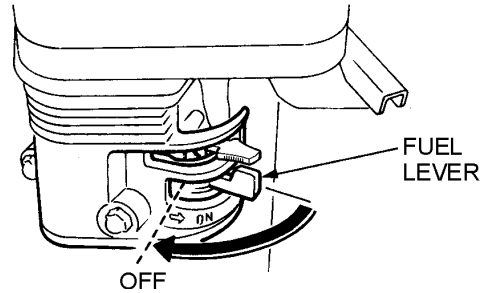

**Figure 24. Fuel Valve Lever (OFF)**

### Emergency Shutdown

1. Move the throttle lever quickly to the **IDLE** position, and place the engine **ON/OFF** switch in the **OFF** position.

## GENERAL MAINTENANCE

General maintenance practices are crucial to the performance and longevity of your compactor. This equipment requires routine cleaning, inspection and lubrication. Reference Table 5 and Table 6 for scheduled engine and compactor maintenance.

The following procedures, devoted to maintenance, can prevent serious compactor damage or malfunctioning.

### NOTICE

Reference **HONDA** engine manual supplied with your compactor for more detailed engine maintenance and troubleshooting.



### CAUTION



**ALWAYS** allow the engine to cool before servicing. **NEVER** attempt any maintenance work on a hot engine.



### CAUTION

**ALWAYS** disconnect the spark plug wire from the spark plug and secure away from the engine before performing maintenance or adjustments on the machine.



### WARNING



Some maintenance operations may require the engine to be run. Ensure that the maintenance area is well ventilated. Gasoline engine exhaust contains poisonous carbon monoxide gas that can cause unconsciousness and may result in **DEATH**

## General Cleanliness

Clean the compactor daily. Remove all dust and debris buildup (mud, clay etc.). If the compactor is steam-cleaned, ensure that lubrication is accomplished **AFTER** steam cleaning.

### NOTICE

Inspection and other services should always be carried out on hard and level ground with the engine shutdown.

### NOTICE

The inspection intervals listed in the maintenance tables are for operation under normal conditions. Adjust your inspection intervals based on the number hours plate compactor is in use, and particular working conditions.

# MAINTENANCE

To make sure your plate compactor is always in good working condition before using, carry out the maintenance inspection in accordance with Table 5 and Table 6.

## ENGINE MAINTENANCE

Perform engine maintenance as listed in Table 5.

Table 5. Engine Maintenance Schedule							
Description (3)	Operation	Before	First Month or 10 hrs	Every 3 Months or 25 hrs	Every 6 Months or 50 hrs	Every Year or 100 hrs	Every 2 Years or 200 hrs
Engine Oil	CHECK	X					
	CHANGE		X				
Air Cleaner	CHECK	X					
	CHANGE			X (1)			
All Nuts and Bolts	Re-tighten If Necessary	X					
Spark Plug	CHECK-CLEAN				X		
	REPLACE						X
Cooling Fins	CHECK				X		
Spark Arrester	CLEAN					X	
Fuel Tank	CLEAN					X	
Fuel Filter	CHECK					X	
Idle Speed	CHECK-ADJUST					X (2)	
Valve Clearance	CHECK-ADJUST						X (2)
Fuel lines	CHECK	Every 2 years (replace if necessary) (2)					

1. Service more frequently when used in **DUSTY** areas.
2. These items should be serviced by your service dealer, unless you have the proper tools and are mechanically proficient. Refer to the **HONDA** Shop Manual for service procedures.
3. For commercial use, log hours of operation to determine proper maintenance intervals.



## MACHINE INSPECTION

Perform machine inspection as listed in Table 6.

Interval	Check	Solution
Daily Before Starting	Machine	Clean if necessary.
	Fuel Tank For Leaks	Repair fuel leaks.
	Fuel System for Leaks	Repair fuel leaks.
	Engine Oil	Add oil if necessary.
	Vibrator Oil	Add oil if necessary.
	Air Cleaner Element	Clean/Replace
	Guard Frame	Inspect/deformations
	Shock Absorber	Replace if damaged.
	Hydraulic Pump	Check/Repair Leaks
	Hydraulic Pipe System	Check/Repair leaks, Inspect for wear
	Direction Control Lever	Check bolts/nuts, Inspect for wear
	Duct Hose	Check for crack/damage
Every 20 Hours	Engine Oil/Oil Filter	Replace only after first 20 hrs.
Every 100 Hours	Engine Oil	Change
	Engine Oil Filter	Wash
	Vibrator Oil	Check oil level. Check for leaks/dirt.
	Hydraulic Oil	Check oil level. Check for leaks.
Every 200 hours	V-Belt	Inspect, replace if damaged or worn.
	Clutch	Inspect, replace if not working properly.
	Engine Bolts	Replace bolts if deformed or elongated.
Every 300 hours	Vibrator Oil	Change
	Fuel Filter	Change
	Hydraulic Oil	Change
	Engine Oil Filter	Change
Every 2 years	Fuel Lines	Replace

## TIGHTENING TORQUE

Reference Table 7 below (Tightening Torque ), for retightening of nuts and bolts.

Material	6mm	8mm	10mm	12mm	14mm	16mm	18mm	20mm
4T	70	150	300	500	750	1,100	1,400	2,000
6-8T	100	250	500	800	1,300	2,000	2,700	3,800
11T	150	400	800	1,200	2,000	2,900	4,200	5,600
*	100 (6mm) 300 ~ 350 (8mm) 650 ~ 700 (10mm)							
**	In case counter-part is of aluminum							
Bolt threads used with this machine are all right handed								
Material and quality of material is marked on each bolt, and screw.								

## ENGINE CYCLONE AIR CLEANER

**DANGER**

**DO NOT** use gasoline or low flash point solvents for cleaning the air cleaner. The possibility exists of fire or explosion which can cause damage to the equipment and severe bodily harm or even **DEATH!**

**CAUTION**

Wear protective equipment such as approved safety glasses or face shields and dust masks or respirators when cleaning air filters with compressed air.

This engine is equipped with a replaceable, high-density paper air cleaner element. See Figure 25 for air cleaner components.

1. Remove the air cleaner cover and foam filter element.
2. Tap the paper filter element several times on a hard surface to remove dirt, or blow compressed air not exceeding 30 psi (207 kPa, 2.1 kgf/cm<sup>2</sup>) through the filter element from the inside out. **NEVER** brush off dirt. Brushing will force dirt into the fibers. Replace the paper filter element if it is excessively dirty.

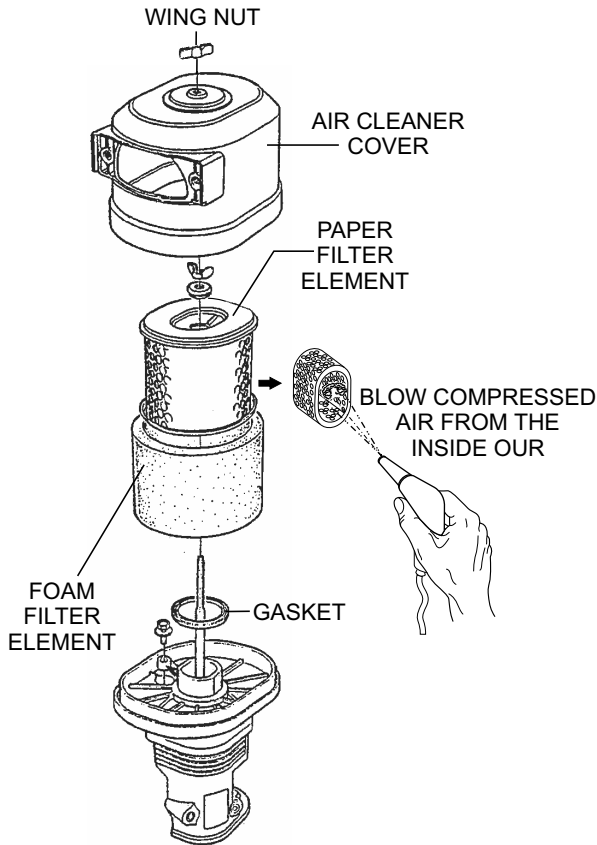

**Figure 25. Cyclone Air Cleaner**

3. Clean foam element in warm, soapy water or nonflammable solvent. Rinse and dry thoroughly. Dip the element in clean engine oil and completely squeeze out the excess oil from the element before installing.

### NOTICE

Operating the engine with loose or damaged air cleaner components could allow unfiltered air into the engine causing premature wear and failure.

### Dust Pot

Always clean the dust pot. A clogged dust pot reduces cyclone effect with cleaner element wearing easily.

1. Remove the four pan head screws that secure the dust pot to pre air cleaner case cover. (Figure 26).

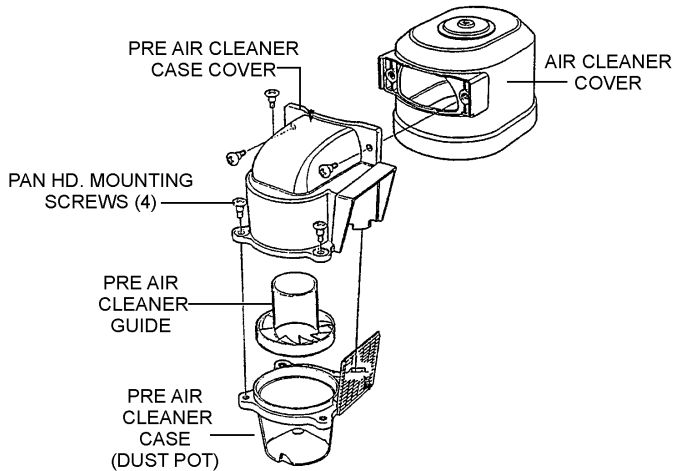

**Figure 26. Removing Dust Pot**

2. Clean dust pot with water and neutral detergent.
3. Reinstall dust pot back onto pre air cleaner case cover.

### ENGINE OIL

#### NOTICE

Drain the engine oil when the oil is warm.

1. Remove the oil drain bolt (Figure 27). and sealing washer and allow the oil to drain into a suitable container.
2. Replace engine oil with recommended type oil as listed in Table 4. For engine oil capacity, see Table 2 (Engine Specifications). **DO NOT** overfill.
3. Reinstall drain bolt with sealing washer and tighten securely.

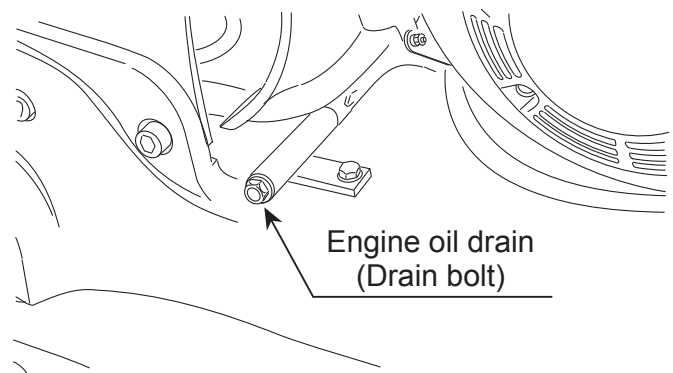

**Figure 27. Draining Engine Oil**

## HYDRAULIC OIL

1. With the handle in vertical position, remove the plug cap from the hydraulic pump (Figure 28).

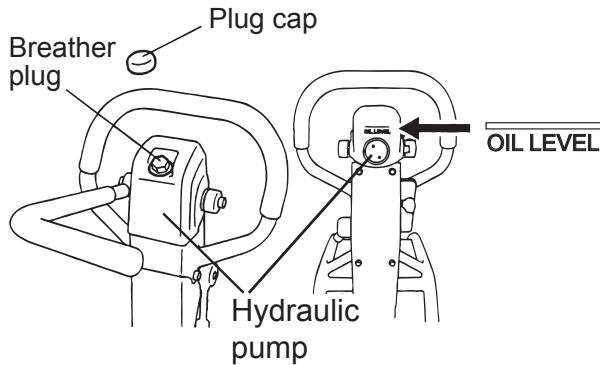

**Figure 28. Removing Plug/Breather Cap**

2. Remove the breather plug with a 24 mm wrench at the top of the hydraulic pump.
3. Remove the hydraulic hose connected to the cylinder on the vibrator side (Figure 29).

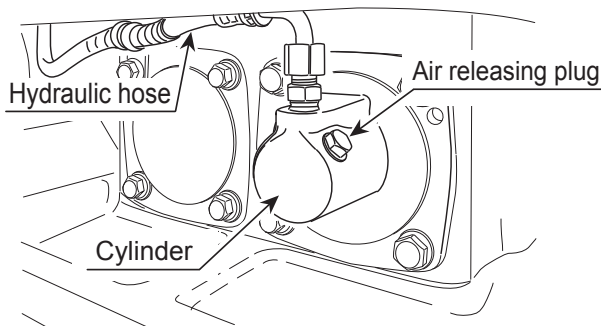

**Figure 29. Removing Hydraulic Hose**

4. Set the run lever to reverse.
5. Drain the hydraulic oil from the pump.
6. After the oil is drained, attach the hydraulic hose again to the cylinder on the vibrator side.

7. With the direction control lever at the forward-most position, secure the guard frame with a rope to immobilize (Figure 30).

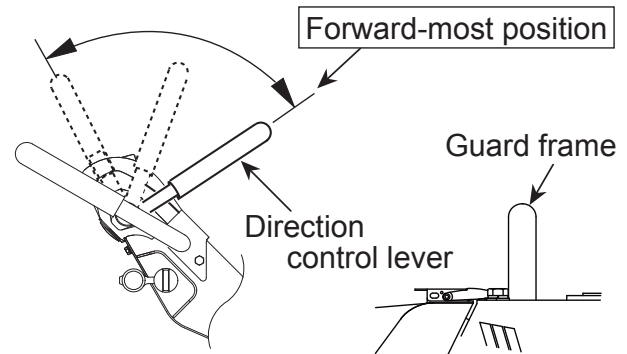

**Figure 30. Direction Control Lever (Forward Position)**

8. Pour hydraulic oil (550 cc) to the hydraulic pump breather plug attachment hole (Figure 28).
9. Remove the air releasing plug of vibrator cylinder. Oil will then come out from the air releasing plug. After air bubbles stop coming out, reattach the plug. Tighten securely (Figure 29).
10. Release the direction control lever and move the lever forward and reverse several times (until no air bubbles are seen). Keep the lever at the forward position for 10 seconds every time. (Because the check valve is opened at the maximum forward position and air bubble will come out from the oil tank of the hydraulic pump).
11. In case the air bleeding is insufficient, repeat steps 9 and 10.
12. Attach the hydraulic pump breather plug and put on the plug cap. After making sure the hydraulic oil in the pump is at OIL LEVEL, attach the breather plug.

**CAUTION**

**DO NOT** exceed OIL LEVEL of hydraulic oil. If the level is higher, oil will burst out from the breather plug.

## SPARK PLUG

### NOTICE

**NEVER** use a spark plug of incorrect heat range.

1. Remove and clean spark plug (Figure 31) with a wire brush if it is to be reused. Discard spark plug if the insulator is cracked or chipped.
2. Using a feeler gauge adjust spark plug gap to 0.028 ~0.031 inch (0.7~0.8 mm).
3. Thread spark plug into cylinder hole by hand to prevent cross-threading, then tighten securely.

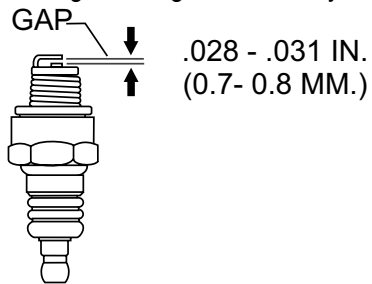

**Figure 31. Spark Plug Gap**

## V-BELT

Visually examine the V-belt (Figure 32) and determine if it is full of tiny cracks, frayed, has pieces of rubber missing, is peeling or otherwise damaged.

Also, examine the belt and determine if it is **oil soaked** or **"glazed"** (hard shiny appearance on the sides of the belt). Either of these two conditions can cause the belt to run hot, which can weaken it and increase the danger of it breaking.

If the V-belt exhibits any of the above wear conditions replace the V-belt immediately.

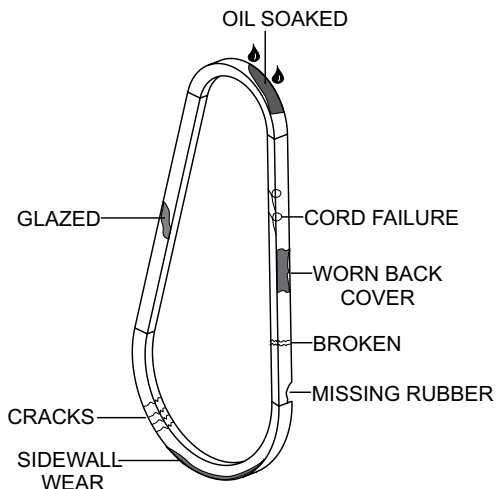
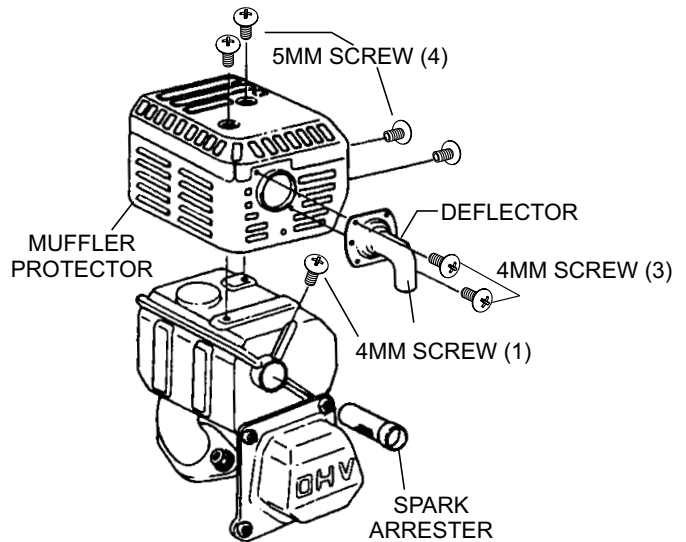

**Figure 32. V-Belt Inspection**

## SPARK ARRESTER CLEANING

Clean the spark arrester every year or 100 hours.

1. Remove the 4 mm screw (3) from the exhaust deflector, then remove the deflector. See (Figure 33).
2. Remove the 5 mm screw (4) from the muffler protector, then remove the muffler protector.
3. Remove the 4 mm screw from the spark arrester, then remove the spark arrester.



**Figure 33. Spark Arrester Removal**

4. Carefully remove carbon deposits from the spark arrester screen (Figure 34) with a wire brush.

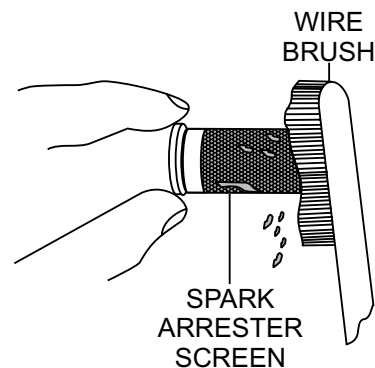

**Figure 34. Cleaning The Spark Arrester**

5. If the spark arrester is damaged and has breaks or holes, replace with a new one.
6. Reinstall the spark arrester and muffler protector in reverse order of disassembly.

## STORAGE

1. Wash off dirt and soil from every part with water. While washing, be careful not to let the water splash on the electric components such as the engine muffler.
2. Cover the machine to prevent dust and dirt buildup.
3. Store the machine in a dry area away from direct sunlight.
4. Do not leave the machine outdoors. Keep it indoors.
5. When not used for a long period of time, drain the fuel from the fuel tank.
6. When the machine is used after a long storage period, check the level of engine oil before using.

## TROUBLESHOOTING (COMPACTOR)

<b>Troubleshooting (Compactor)</b>		
<b>Symptom</b>	<b>Possible Problem</b>	<b>Solution</b>
Travel speed low and vibration weak.	Clutch slips?	Adjust or replace clutch.
	V-belt slips?	Adjust or replace V-belt.
	Excessive oil in vibrator?	Fill to correct level.
	Trouble in vibrator internals?	Check vibrator assembly for any worn or defective parts, replace any defective parts.
	Aeration in hydraulic oil for for travel reversing system?	Purge air in hydraulic oil. (Bleed plug)
	Engine speed incorrect?	Set engine speed to correct RPM.
Travels forward or backward but unable to switch direction.	Hydraulic pump problems?	Check hydraulic pump.
	Direction Control Lever installation wrong?	Correct installation of IDirection Control Lever.
	Broken or defective oil hose?	Replace oil hose.
	Aeration in hydraulic oil?	Purge air in hydraulic oil. (Bleed plug)
	Excessive oil in reversing system?	Fill to correct level.
	Hydraulic pump clogged with trash?	Clean valve inside hydraulic pump.
	Cylinder piston bearing failure?	Check piston bearing in cylinder for leakage.
Does not travel in forward or reverse	V-belt disengaged or slips?	Engage V-belt, adjust or replace.
	Clutch slips?	Adjust clutch, replace if necessary.
	Vibrator locks?	Check vibrator and correct problem.
	Cylinder piston bearing failure?	Check piston bearing in cylinder for leakage at USH packing.
Direction Control Lever operating resistance for reverse is high.	Piston inside hydraulic pump not moving smoothly?	Adjust or replace.
	Vibrator cylinder piston does not move smoothly	Adjust or replace.

# TROUBLESHOOTING (ENGINE)

<b>Troubleshooting (Engine)</b>		
<b>Symptom</b>	<b>Possible Problem</b>	<b>Solution</b>
Difficult to start, fuel is available, but no spark at spark plug.	Spark plug bridging?	Check gap, insulation or replace spark plug.
	Carbon deposit on spark plug?	Clean or replace spark plug.
	Short circuit due to deficient spark plug insulation?	Check spark plug insulation, replace if worn.
	Improper spark plug gap?	Set to proper gap.
	Spark plug is red?	Check transistor ignition unit.
	Spark plug is bluish white?	If insufficient compression, repair or replace engine. If injected air leaking, correct leak. If carburetor jets clogged, clean carburetor.
	No spark present at tip of spark plug?	Check transistor ignition unit is broken, and replace defective unit. Check if voltage cord cracked or broken and replace. Check if spark plug if fouled and replace.
	No oil?	Add oil as required.
	Oil pressure alarm lamp blinks upon starting? (if applicable)	Check automatic shutdown circuit, "oil sensor". (if applicable)
Difficult to start, fuel is available, and spark is present at the spark plug.	ON/OFF switch is shorted?	Check switch wiring, replace switch.
	Ignition coil defective?	Replace ignition coil.
	Improper spark gap, points dirty?	Set correct spark gap and clean points.
	Condenser insulation worn or short circuiting?	Replace condenser.
	Spark plug wire broken or short circuiting?	Replace defective spark plug wiring.
Difficult to start, fuel is available, spark is present and compression is normal.	Wrong fuel type?	Flush fuel system, replace with correct type of fuel.
	Water or dust in fuel system?	Flush fuel system.
	Air cleaner dirty?	Clean or replace air cleaner.
	Choke open?	Close choke.
Difficult to start, fuel is available, spark is present and compression is low.	Suction/exhaust valve stuck or protruded?	Reseat valves.
	Piston ring and/or cylinder worn?	Replace piston rings and/or piston.
	Cylinder head and/or spark plug not tightened properly?	Torque cylinder head bolts and spark plug.
	Head gasket and/or spark plug gasket damaged?	Replace head and spark plug gaskets.
No fuel present at carburetor.	No fuel in fuel tank?	Fill with correct type of fuel.
	Fuel cock does not open properly?	Apply lubricant to loosen fuel cock lever, replace if necessary.
	Fuel filter/lines clogged?	Replace fuel filter.
	Fuel tank cap breather hole clogged?	Clean or replace fuel tank cap.
	Air in fuel line?	Bleed fuel line.

# TROUBLESHOOTING (ENGINE)

<b>Troubleshooting (Engine) - continued</b>		
<b>Symptom</b>	<b>Possible Problem</b>	<b>Solution</b>
Weak in power, compression is proper and does not misfire.	Air cleaner dirty?	Clean or replace air cleaner.
	Improper level in carburetor?	Check float adjustment, rebuild carburetor.
	Defective spark plug?	Clean or replace spark plug.
	Improper spark plug?	Set to proper gap.
Weak in power, compression is proper but misfires.	Water in fuel system?	Flush fuel system and replace with correct type of fuel.
	Dirty spark plug?	Clean or replace spark plug.
	Ignition coil defective?	Replace ignition coil.
Engine overheats	Wrong type of fuel?	Replace with correct type of fuel.
	Cooling fins dirty?	Clean cooling fins.
	Intake air restricted?	Clear intake of dirt and debris. Replace air cleaner elements as necessary.
	Oil level too low or too high?	Adjust oil to proper level.
Rotational speed fluctuates.	Governor adjusted incorrectly?	Adjust governor.
	Governor spring defective?	Replace governor spring.
	Fuel flow restricted?	Check entire fuel system for leaks or clogs.
Recoil starter malfunctions. (if applicable)	Recoil mechanism clogged with dust and dirt?	Clean recoil assembly with soap and water.
	Spiral spring loose?	Replace spiral spring.
Starter malfunctions.	Loose, damaged wiring?	Ensure tight, clean connections on battery and starter.
	Battery insufficiently charged?	Recharge or replace battery.
	Starter damaged or internally shorted?	Replace starter.
Burns too much fuel.	Over-accumulation of exhaust products?	Check and clean valves. Check muffler and replace if necessary.
	Wrong spark plug?	Replace spark plug with manufacturer's suggested type.
Exhaust color is continuously "white".	Lubricating oil is wrong viscosity?	Replace lubricating oil with correct viscosity.
	Worn rings?	Replace rings.
Exhaust color is continuously "black".	Air cleaner clogged?	Clean or replace air cleaner.
	Choke valve set to incorrect position?	Adjust choke valve to correct position.
	Carburetor defective, seal on carburetor broken?	Replace carburetor or seal.
	Poor carburetor adjustment, engine runs too rich?	Adjust carburetor.
Will not start, no power with key "ON". (if applicable)	ON/OFF device not activated ON?	Turn on ON/OFF device.
	Battery disconnected or discharged?	Check cable connections. Charge or replace battery
	Ignition switch/wiring defective?	Replace ignition switch. Check wiring.





# EXPLANATION OF CODE IN REMARKS COLUMN

The following section explains the different symbols and remarks used in the Parts section of this manual. Use the help numbers found on the back page of the manual if there are any questions.

## NOTICE

The contents and part numbers listed in the parts section are subject to change **without notice**. Multiquip does not guarantee the availability of the parts listed.

## SAMPLE PARTS LIST

NO.	PART NO.	PART NAME	QTY.	REMARKS
1	12345	BOLT .....	1	INCLUDES ITEMS W/%
2%		WASHER, 1/4 IN. ....		NOT SOLD SEPARATELY
2%	12347	WASHER, 3/8 IN. ...	1	MQ-45T ONLY
3	12348	HOSE .....	A/R	MAKE LOCALLY
4	12349	BEARING .....	1	S/N 2345B AND ABOVE

## NO. Column

**Unique Symbols** — All items with same unique symbol (@, #, +, %, or >) in the number column belong to the same assembly or kit, which is indicated by a note in the “Remarks” column.

**Duplicate Item Numbers** — Duplicate numbers indicate multiple part numbers, which are in effect for the same general item, such as different size saw blade guards in use or a part that has been updated on newer versions of the same machine.

## NOTICE

When ordering a part that has more than one item number listed, check the remarks column for help in determining the proper part to order.

## PART NO. Column

**Numbers Used** — Part numbers can be indicated by a number, a blank entry, or TBD.

TBD (To Be Determined) is generally used to show a part that has not been assigned a formal part number at the time of publication.

A blank entry generally indicates that the item is not sold separately or is not sold by Multiquip. Other entries will be clarified in the “Remarks” Column.

## QTY. Column

**Numbers Used** — Item quantity can be indicated by a number, a blank entry, or A/R.

A/R (As Required) is generally used for hoses or other parts that are sold in bulk and cut to length.

A blank entry generally indicates that the item is not sold separately. Other entries will be clarified in the “Remarks” Column.

## REMARKS Column

Some of the most common notes found in the “Remarks” Column are listed below. Other additional notes needed to describe the item can also be shown.

**Assembly/Kit** — All items on the parts list with the same unique symbol will be included when this item is purchased.

Indicated by:

“INCLUDES ITEMS W/(unique symbol)”

**Serial Number Break** — Used to list an effective serial number range where a particular part is used.

Indicated by:

“S/N XXXXX AND BELOW”

“S/N XXXX AND ABOVE”

“S/N XXXX TO S/N XXX”

**Specific Model Number Use** — Indicates that the part is used only with the specific model number or model number variant listed. It can also be used to show a part is NOT used on a specific model or model number variant.

Indicated by:

“XXXXX ONLY”

“NOT USED ON XXXX”

**“Make/Obtain Locally”** — Indicates that the part can be purchased at any hardware shop or made out of available items. Examples include battery cables, shims, and certain washers and nuts.

**“Not Sold Separately”** — Indicates that an item cannot be purchased as a separate item and is either part of an assembly/kit that can be purchased, or is not available for sale through Multiquip.

## SUGGESTED SPARE PARTS

---

### MVH208GH PLATE COMPACTOR WITH HONDA GX240UT2SMXC GASOLINE ENGINE

#### 1 to 5 units

Qty.	P/N	Description
3	.....070200383.....	V-BELT
5	.....9807956855.....	SPARK PLUG
1	.....28462ZE2W11.....	ROPE, RECOIL STARTER
5	.....17210ZE3505.....	ELEMENT, AIR CLEANER
1	.....17620Z4H900.....	CAP, FUEL TANK
1	.....17672Z4H000.....	FUEL FILTER, FUEL TANK
4	.....939010480.....	SHOCK ABSORBER

#### **NOTICE**

Part numbers on this Suggested Spare Parts list may supersede/replace the part numbers shown in the following parts lists.

# VIBRATING PLATE ASSY.

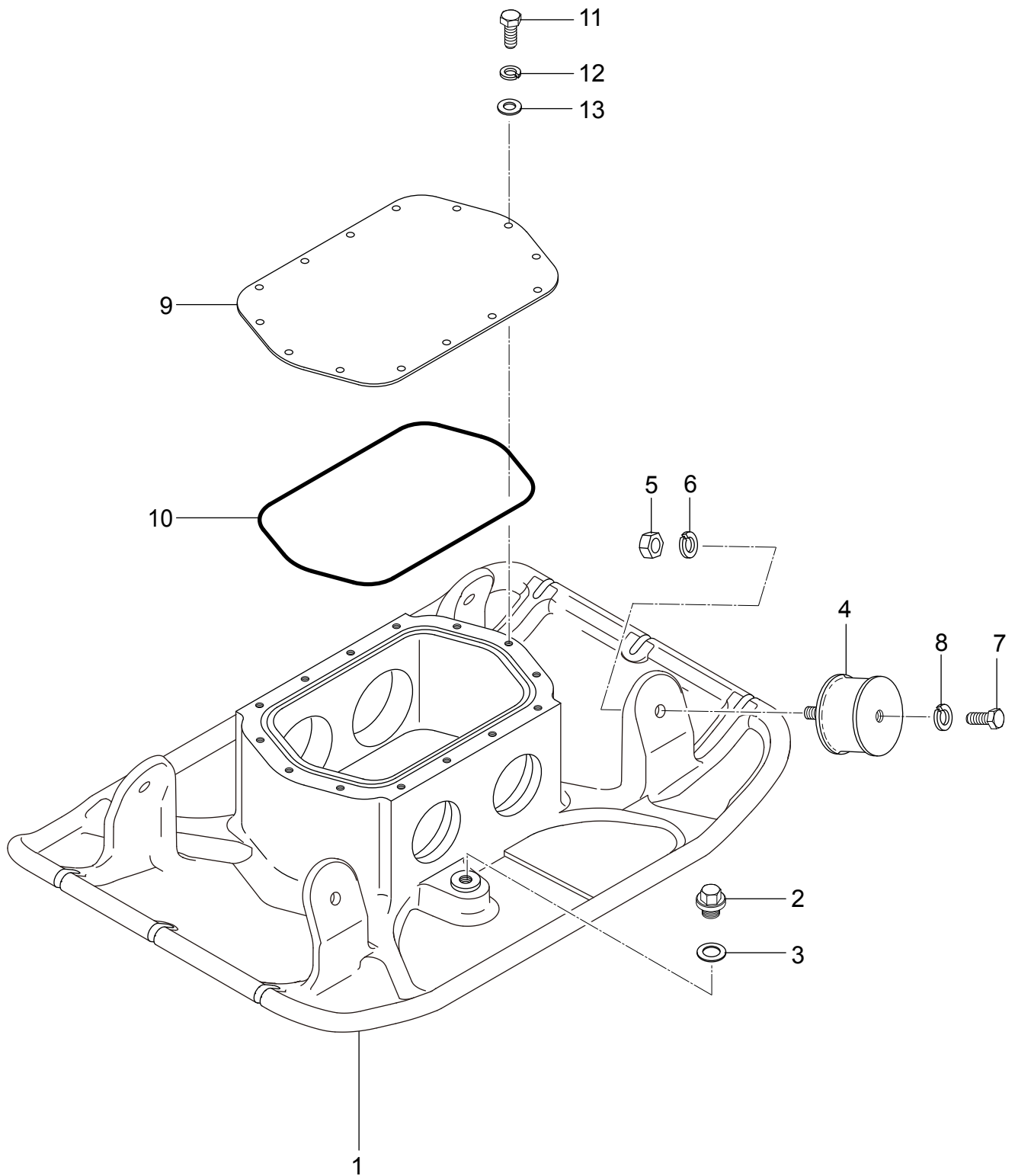

## VIBRATING PLATE ASSY.

---

<u>NO.</u>	<u>PART NO.</u>	<u>PART NAME</u>	<u>QTY.</u>	<u>REMARKS</u>
1	470121760	VIBRATING PLATE, 500MM	1	
2	953405270	PLUG 1/4X14 13L	1	
3	953405260	PACKING 1/4 (CU)	1	
4	939010480	SHOCK ABSORBER	4	
5	0039312000	NUT M12.....	4.....	REPLACES P/N 020312100
6	030212300	WASHER, LOCK M12	4	
7	012012030	BOLT 12X30.....	4.....	REPLACES P/N 001221230
8	030212300	WASHER, LOCK M12	4	
9	470353610	COVER, VIBRATOR	1	
10	050710150	O-RING	1	
11	014208020	BOLT 8X20.....	14.....	REPLACES P/N 001220820
12	030208200	WASHER, LOCK M8	14	
13	0401450080	WASHER, FLAT M8.....	14.....	REPLACES P/N 031108160

# VIBRATOR ASSY.

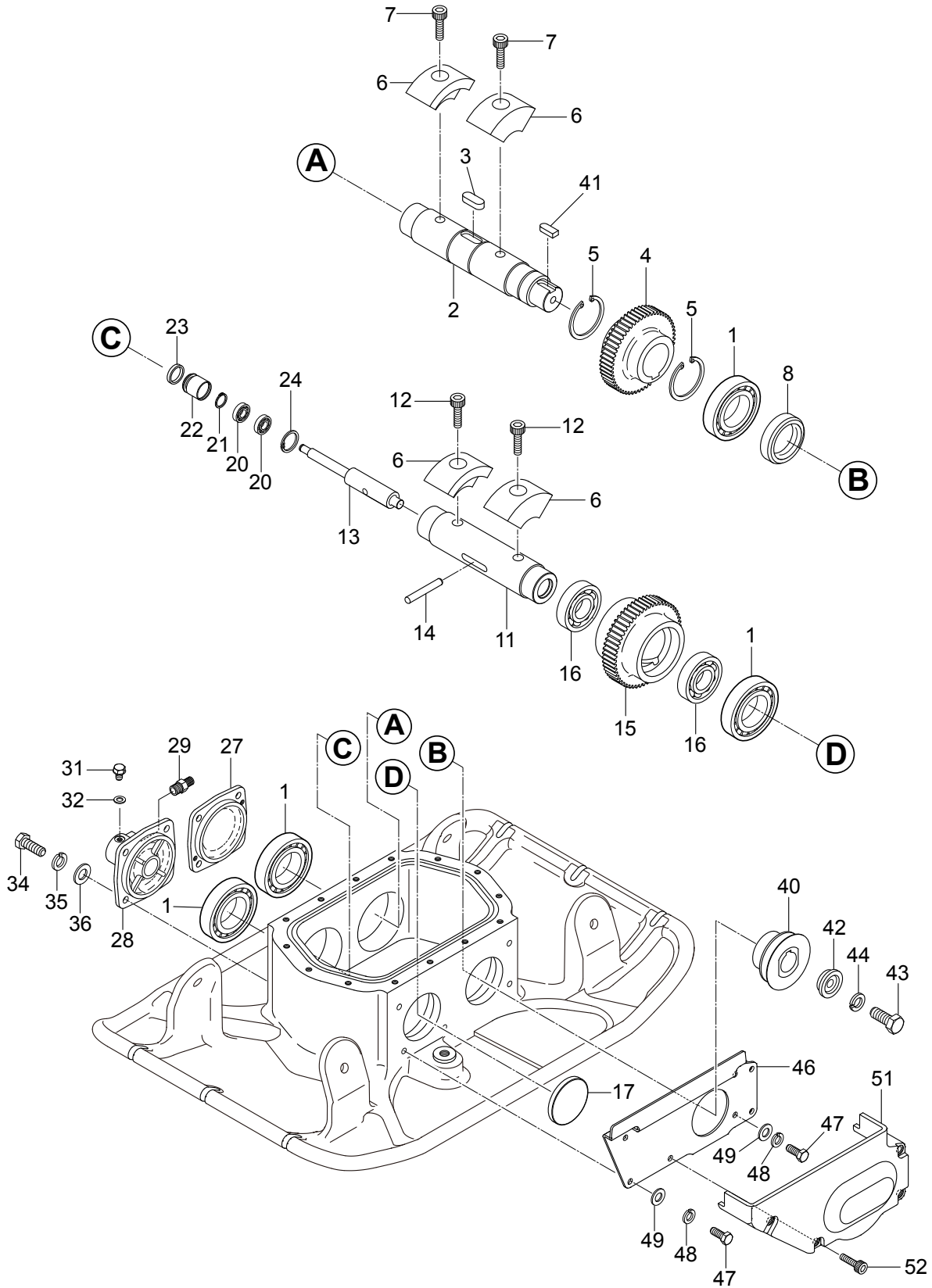

# VIBRATOR ASSY.

<u>NO.</u>	<u>PART NO.</u>	<u>PART NAME</u>	<u>QTY.</u>	<u>REMARKS</u>
1	047920130	ROLLER BEARING	4	
2	470353710	ROTARY SHAFT, DRIVE	1	
3	951405370	KEY 15X10X39 RR	1	
4	466347900	GEAR, DRIVE	1	
5	080200500	STOP RING	2	
6	470353760	ECCENTRIC ROTATOR	4	
7	009120309	SOCKET HEAD BOLT 12X40	2	
8	060104020	OIL SEAL	1	
11	466347790	ROTARY SHAFT, DRIVEN	1	
12	009120308	SOCKET HEAD BOLT 12X25	2	
13	466347860	PISTON ROD	1	
14	025510063	KNOCK PIN 10X63	1	
15	470353720	GEAR, DRIVEN	1	
16	040006910	BEARING	2	
17	953010040	SEAL CAP	1	
20	042506000	BEARING	2	
21	0080000010	STOP RING .....	1	REPLACES P/N 080200100
22	455435051	PISTON	1	
23	455010070	PACKING	1	
24	080100260	STOP RING	1	
27	470353730	BEARING COVER	1	
28	470353740	CYLINDER (R)	1	
29	954010020	CONNECTOR PT, PF1/4	1	
31	011008015	BOLT 8X12.....	1	REPLACES P/N 001220812
32	953404600	COPPER PACKING 8.2X16X1.6	1	
34	001220825	BOLT 8X25.....	8	REPLACES P/N 011208025
35	030208200	WASHER, LOCK M8	8	
36	0401450080	WASHER, FLAT M8.....	8	REPLACES P/N 031108160
40	470353770	PULLEY	1	
41	951403610	KEY 10X8X30	1	
42	470468730	WASHER	1	
43	012012030	BOLT 12X30.....	1	REPLACES P/N 001221230
44	030212300	WASHER, LOCK M12	1	
46	470353750	GUIDE, BELT COVER	1	
47	014208020	BOLT 8X20.....	3	REPLACES P/N 001220820
48	030208200	WASHER, LOCK M8	3	
49	031108160	WASHER, FLAT M8	3	
51	470219540	BELT COVER, LOWER	1	
52	001520854	SOCKET HEAD BOLT 8X70	4	

# BASE AND ENGINE ASSY.

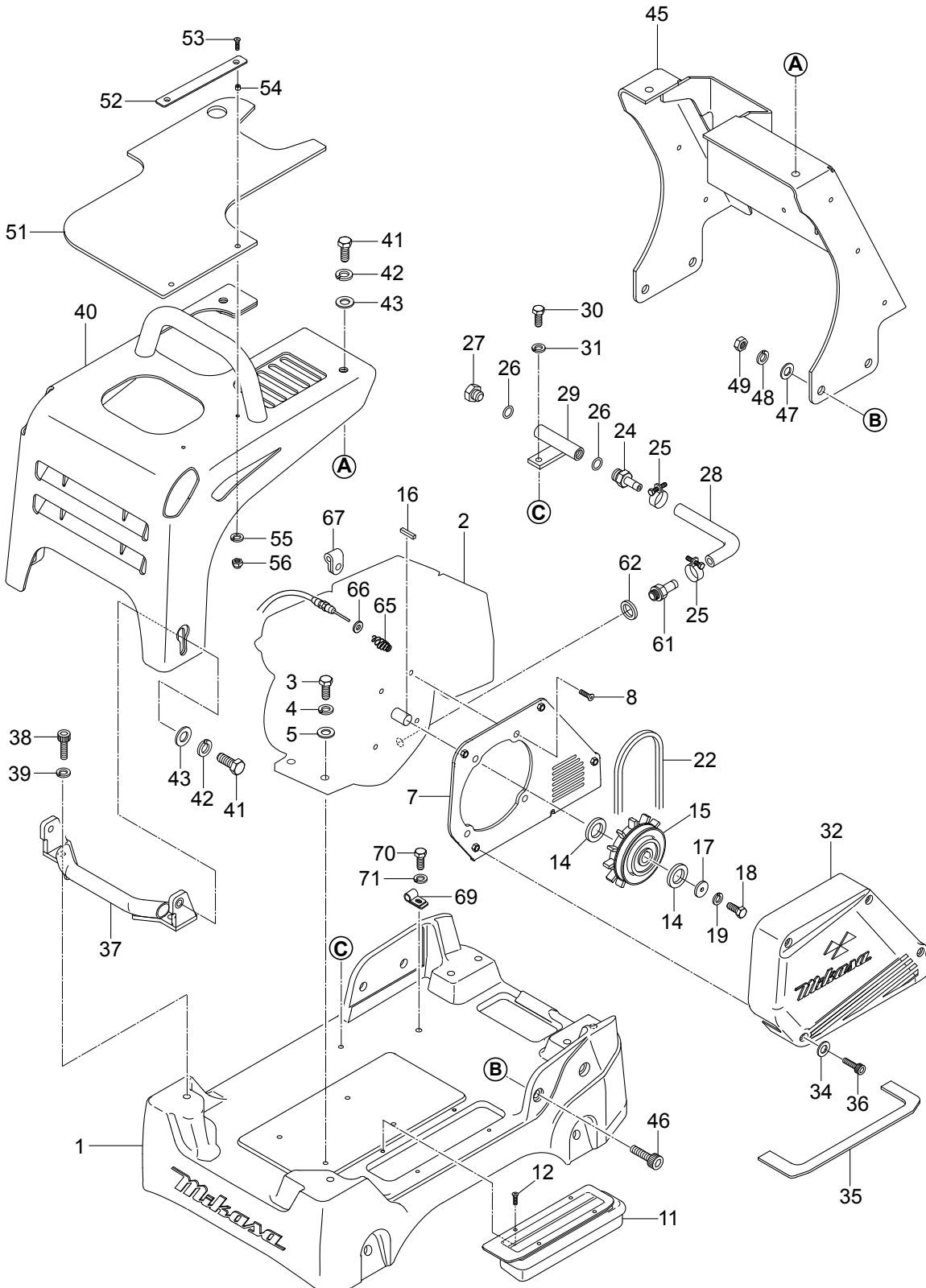



## BASE AND ENGINE ASSY.

<u>NO.</u>	<u>PART NO.</u>	<u>PART NAME</u>	<u>QTY.</u>	<u>REMARKS</u>
1	470121850	BASE	1	
2	912224006	ENGINE ASSY., GX240UT2SMXC	1	
3	0105051045	BOLT 10X45.....	4	REPLACES P/N 001221045
4	030210250	WASHER, LOCK M10	4	
5	031110160	WASHER, FLAT M10	4	
7	470353680	BELT COVER, IN	1	
8	009110071	SOCKET HEAD BOLT 10X25	4	
11	470219530	DUST COVER	1	
12	092006010	FLAT HEAD SCREW 6X10	4	
14	952409450	SPACER 25X40X5	2	
15	456343340	CLUTCH ASSY.	1	
16	951400110	KEY 7X7X35	1	
17	952400690	WASHER 9X35X4.5	1	
18	011208030	BOLT 8X30.....	1	REPLACES P/N 001220830
19	030208200	WASHER, LOCK M8	1	
22	070200383	V-BELT B-38 GREEN	1	
24	954407310	UNION, DRAIN	1	
25	0091720000	HOSE, CLAMP	2	
26	0211140020	GASKET	2	
27	0401140030	PLUG	1	
28	465459390	DRAIN HOSE	1	
29	464457380	DRAIN JOINT	1	
30	014208020	BOLT 8X20.....	1	REPLACES P/N 001220820
31	030208200	WASHER, LOCK M8	1	
32	470121780	BELT COVER (OUT)	1	
34	033910220	WASHER 8.4X15.5X1.6	4	
35	470353640	DUST SPONGE (OUT)	1	
36	001520854	SOCKET HEAD BOLT 8X70	4	
37	470353650	FRONT BUMPER	1	
38	014212035	SOCKET HEAD BOLT 12X35.....	2	REPLACES P/N 001521235
39	030212300	WASHER, LOCK M12	2	
40	470121830	FRONT COVER	1	
41	012212035	BOLT 12X35.....	4	REPLACES P/N 001221235
42	030212300	WASHER, LOCK M12	4	
43	031112230	WASHER, FLAT M12	4	
45	470121840	CENTER COVER	1	
46	014212035	SOCKET HEAD BOLT 12X35.....	4	REPLACES P/N 001521235
47	031112230	WASHER, LOCK M12	4	
48	030212300	WASHER, FLAT M12	4	
49	0039312000	NUT M12.....	4	REPLACES P/N 020312100



## **BASE AND ENGINE ASSY. (CONTINUED)**

<b>NO.</b>	<b>PART NO.</b>	<b>PART NAME</b>	<b>QTY.</b>	<b>REMARKS</b>
51	470468810	RUBBER COVER, UPPER	1	
52	467466810	STOPPER, COVER	1	
53	009120424	SOCKET HEAD BOLT 6X25	2	
54	617465130	COLLAR 6.2X7.8X4.5	2	
55	030206150	WASHER, LOCK M6	2	
56	022710607	NYLON NUT M6	2	
61	90131ZE3790	DRAIN JOINT	1	
62	031112230	WASHER, DRAIN PLUG M12 .....	1	REPLACES P/N 9410912000
65	402010110	COIL SPRING .....	1	REPLACES P/N 0830000010
66	58151	WASHER, FLAT M5 .....	1	REPLACES P/N 031105080
67	2067550101	CLAMP COMPLETE	1	
69	959407260	CLIP D6	1	
70	012210015	BOLT 10X15 .....	1	REPLACES P/N 001221015
71	030210250	WASHER, LOCK M10	1	

# ELECTRICAL DEVICE ASSY.

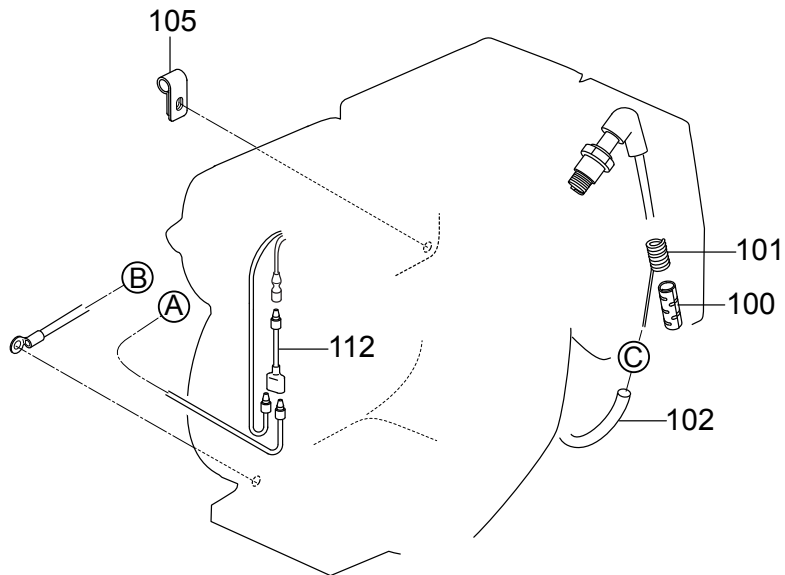
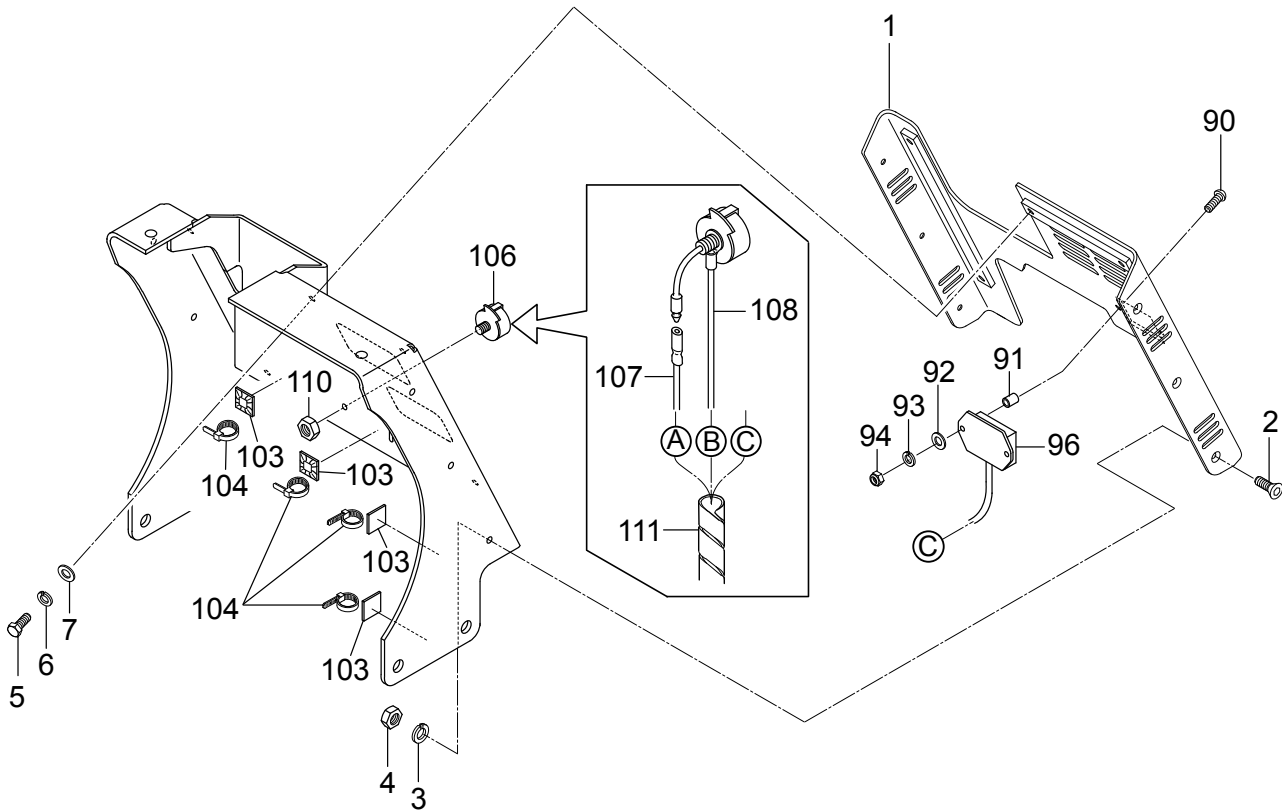

## ELECTRICAL DEVICE ASSY.

<u>NO.</u>	<u>PART NO.</u>	<u>PART NAME</u>	<u>QTY.</u>	<u>REMARKS</u>
1	470219570	REAR COVER	1	
2	009120414	SUNK HEAD BOLT 6X20	6	
3	030206150	WASHER, LOCK M6	6	
4	020106050	NUT M6.....	6.....	REPLACES P/N 020306050
5	001220612	BOLT 6X12	5	
6	030206150	WASHER, LOCK M6	5	
7	952404470	WASHER, FLAT M6.....	5.....	REPLACES P/N 031106100
90	009110072	PAN HEAD SCREW 5X35	2	
91	952407930	COLLAR 6X10X13.5	2	
92	58151	WASHER, FLAT M5.....	2.....	REPLACES P/N 031105080
93	030205130	WASHER, FLAT M5	2	
94	022710506	NYLON NUT M5	2	
96	955010311	TACH/HOUR METER	1	
100	955010307	CLIP BELT	1	
101	955010308	CURL CORD	1	
102	959026828	RUBBER TUBE	1	
103	955407970	WIRING FIXED BASE	4	
104	506010070	CLAMP	4	
105	2067550101	CLAMP COMPLETE	1	
106	955301010	STOP SWITCH, ENGINE	1	
107	468467570	READ CORD	1	
108	467466980	LEAD WIRE (SW-GROUND)	1	
110	020108060	NUT M8.....	1.....	REPLACES P/N 020308060
111	959021827	SPIRAL TUBE 6D-950L	1	
112	515450380	WIRE HARNESS	1	

# CONTROL ASSY.

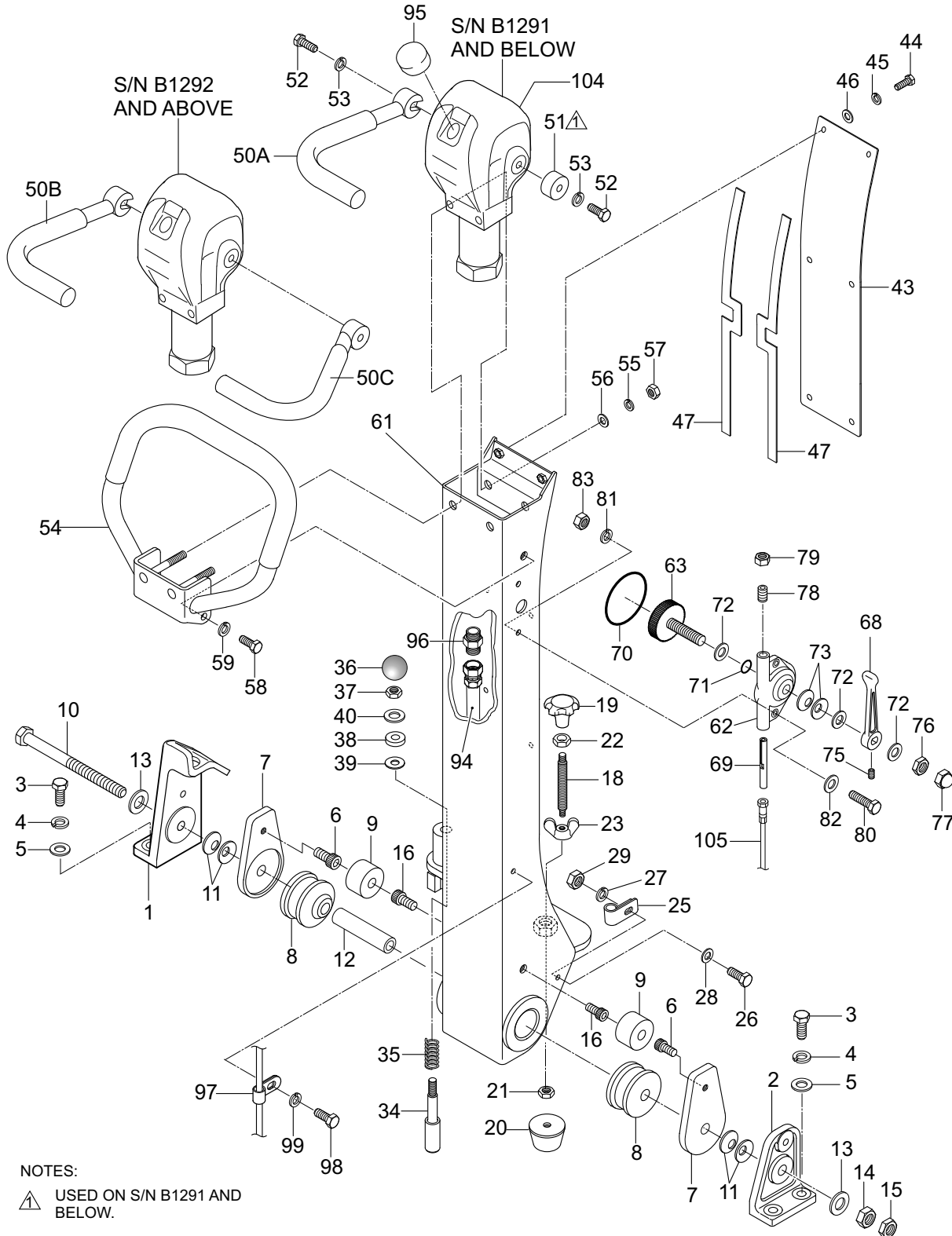

## CONTROL ASSY.

<u>NO.</u>	<u>PART NO.</u>	<u>PART NAME</u>	<u>QTY.</u>	<u>REMARKS</u>
1	467351951	HANDLE BRACKET (R)	1	
2	456336420	HANDLE BRACKET (R)	1	
3	012212035	BOLT 12X35.....	4	REPLACES P/N 001221235
4	030212300	WASHER, LOCK M12	4	
5	031112230	WASHER, FLAT M12	4	
6	001521010	SOCKET HEAD BOLT 10X10	2	
7	470468800	GUIDE, HANDLE	2	
8	456449940	SHOCK ABSORBER	2	
9	470468900	CUSHION RUBBER 16X50X30	2	
10	001221681	BOLT 16X250	1	
11	032216350	CONICAL WASHER, LOCK M16	4	
12	470469100	RUBBER TUBE 15.9X25X120L	1	
13	0401450160	WASHER, FLAT M16.....	2	REPLACES P/N 031116260
14	020316130	NUT M16	1	
15	020416100	NUT M16	1	
16	470468920	BOLT, CUSHION RUBBER	2	
18	455434950	SPINDLE	1	
19	455010030	KNOB	1	
20	939009470	STOPPER RUBBER	1	
21	020310080	NUT M10.....	1	REPLACES P/N 020410060
22	020412070	NUT M12	1	
23	022411635	WING NUT M16	1	
25	959408930	CLIP 15 (M6)	1	
26	011206020	BOLT 6X20.....	1	REPLACES P/N 001220620
27	030206150	WASHER, LOCK M6	1	
28	952404470	WASHER, FLAT M6.....	1	REPLACES P/N 031106100
29	020106050	NUT M6.....	1	REPLACES P/N 020306050
34	501402870	HANDLE STOPPER	1	
35	501402880	SPRING/HANDLE	1	
36	959403460	BALL GRIP	1	
37	020310080	NUT M10.....	1	REPLACES P/N 020410060
38	456449980	RUBBER PACKING	1	
39	953405260	PACKING 1/4	1	
40	031110160	WASHER, FLAT M10	1	
43	466217890	HANDLE COVER	1	
44	011206020	BOLT 6X20.....	6	REPLACES P/N 001220620
45	030206150	WASHER, LOCK M6	6	
46	952404470	WASHER, FLAT M6.....	6	REPLACES P/N 031106100
47	466462010	PACKING, HANDLE COVER	2	
50A	464216630	TRAVEL LEVER, RIGHT .....	1	S/N B1291 AND BELOW
50B	464216820	TRAVEL LEVER, RIGHT .....	1	S/N B1292 AND ABOVE
50C	464216830	TRAVEL LEVER, LEFT.....	1	S/N B1292 AND ABOVE
51	464457400	HANDLE BOSS .....	1	S/N B1291 AND BELOW

# CONTROL ASSY. (CONTINUED)

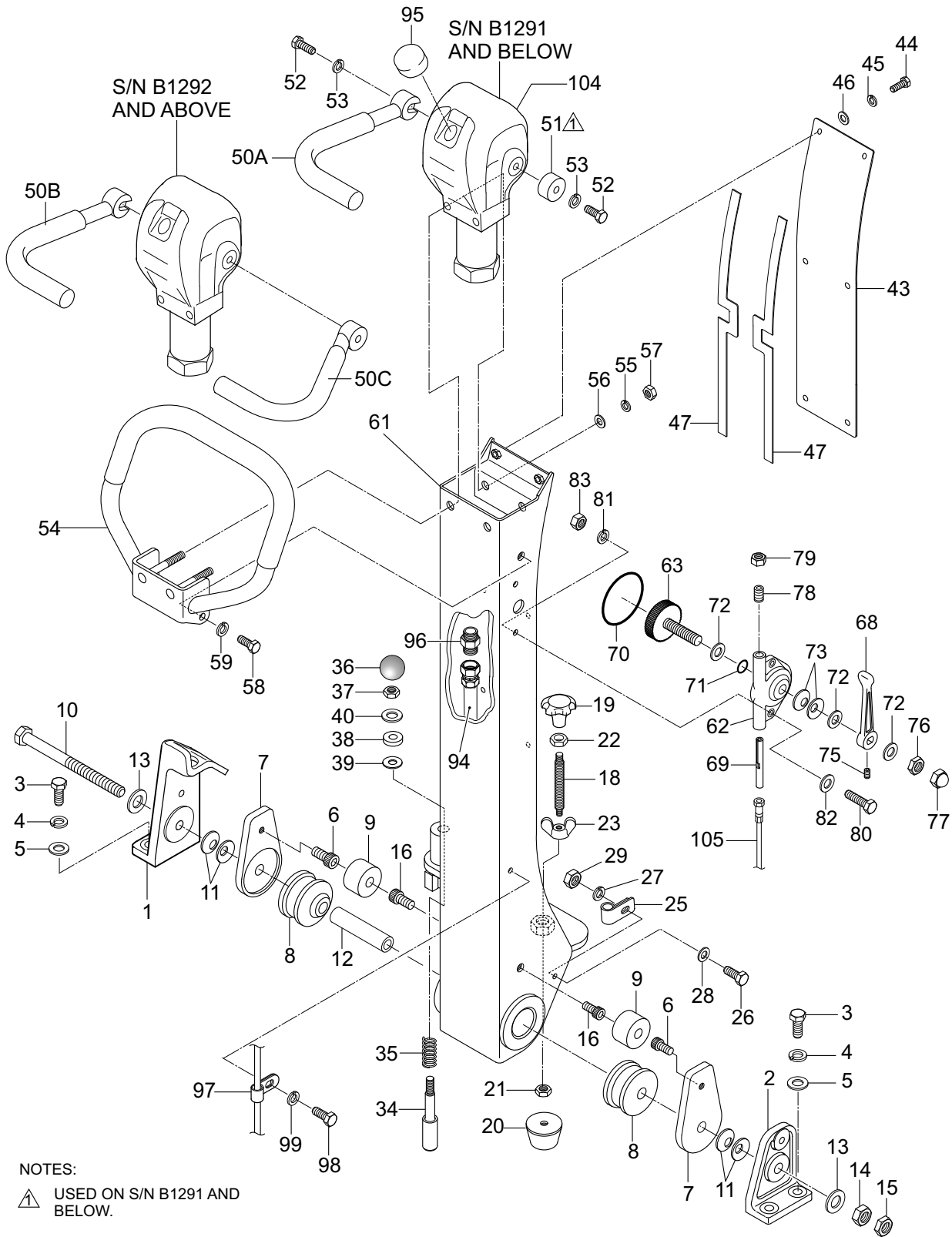



## CONTROL ASSY. (CONTINUED)

<u>NO.</u>	<u>PART NO.</u>	<u>PART NAME</u>	<u>QTY.</u>	<u>REMARKS</u>
52	012010030	BOLT 10X30.....	2.....	REPLACES P/N 001221030
53	030210250	WASHER, LOCK M10	2	
54	467218900	GRIP	1	
55	030210250	WASHER, LOCK M10	2	
56	031110160	WASHER, FLAT M10	2	
57	020310080	NUT M10	2	
58	0105091025	BOLT 10X25.....	2.....	REPLACES P/N 001221025
59	030210250	WASHER, LOCK M10	2	
61	470121870	HANDLE BAR	1	
62	362341550	THROTTLE BODY	1	
63	362910090	THROTTLE, GEAR COMPLETE, W/BOLT	1	
68	362455630	THROTTLE LEVER	1	
69	362455620	SLIDER	1	
70	050100450	O-RING	1	
71	050200100	O-RING	1	
72	031110160	WASHER, FLAT M10	3	
73	032110180	CONICAL WASHER, LOCK M10	2	
75	096206006	SOCKET HEAD SCREW 6X6	1	
76	020310080	NUT M10.....	1.....	REPLACES P/N 020410060
77	022131008	CAP NUT M10	1	
78	014208020	SOCKET HEAD SCREW 8X20 .....	1.....	REPLACES P/N 096208020
79	020408050	NUT M8	1	
80	011606025	BOLT 6X25.....	1.....	REPLACES P/N 001220625
81	030206150	WASHER, LOCK M6	1	
82	952404470	WASHER, FLAT M6.....	1.....	REPLACES P/N 031106100
83	020106050	NUT M6.....	1.....	REPLACES P/N 020306050
94	954003280	OIL HOSE 1100L	1	
95	458451630	BREATHER CAP	1	
96	954003150	MALE CONNECTOR, O-RING 1/4	1	
97	2067550101	CLAMP COMPLETE	1	
98	0105050616	BOLT 6X15.....	1.....	REPLACES P/N 001220615
99	030206150	WASHER, LOCK M6	1	
104	470219590	HAND PUMP	1	
105	956100074	THROTTLE WIRE 1540	1	

# NAMEPLATE AND DECALS ASSY.

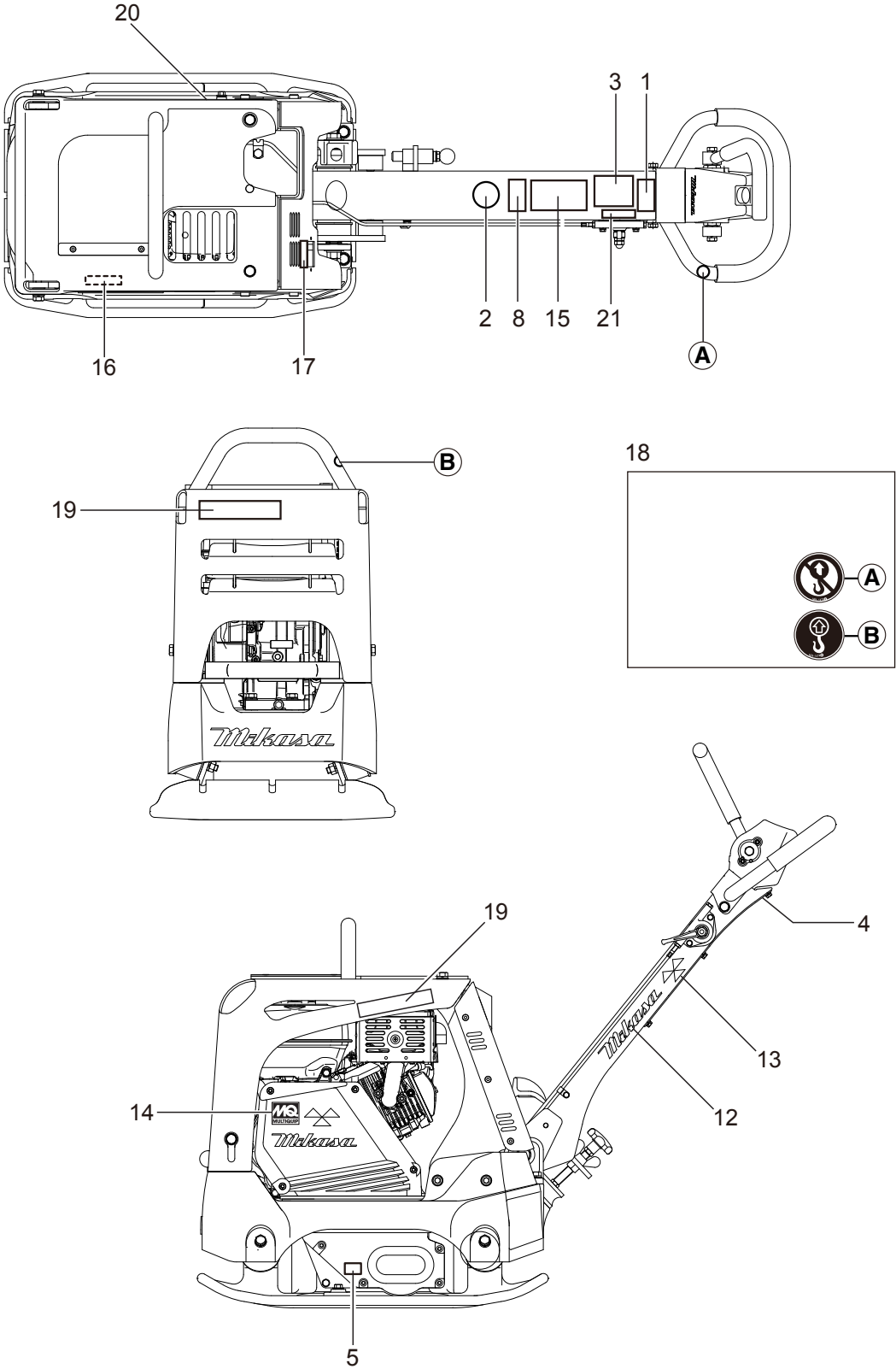

## NAMEPLATE AND DECALS ASSY.

---

<u>NO.</u>	<u>PART NO.</u>	<u>PART NAME</u>	<u>QTY.</u>	<u>REMARKS</u>
1	920204580	DECAL: FULL THROTTLE	1	
2	920203330	EAR PROTECTION LABEL	1	
3	920211060	DECAL: CAUTION (LEVER)	1	
4	920211090	DECAL: SHELL TELLUS OIL 32	1	
5	920201950	DECAL: OIL SAE 10W-30	1	
8	920214100	DECAL: E/G FIRE WARNING	1	
12	920217130	DECAL: MIKASA MARK (W) 200L	2	
13	920217110	DECAL: MIKASA MARK 35X70	2	
14	920220220	DECAL: MQ MARK 72X57	1	
15	920218390	DECAL: CAUTION	1	
16	920220140	DECAL: V-BELT HDPF-5380	1	
17	920218140	DECAL: E/G RPM 3400	1	
18	920900090	DECAL: SET/MVC-MCD/EXP, EU	1	
19	920220080	DECAL: MODEL(R, OR)	2	
20	920220090	DECAL: MODEL(L, OR)	1	
21	920211690	DECAL: LEVER OPERATION	1	

# HONDA GX240UT2SMXC ENGINE — CYLINDER HEAD ASSY.

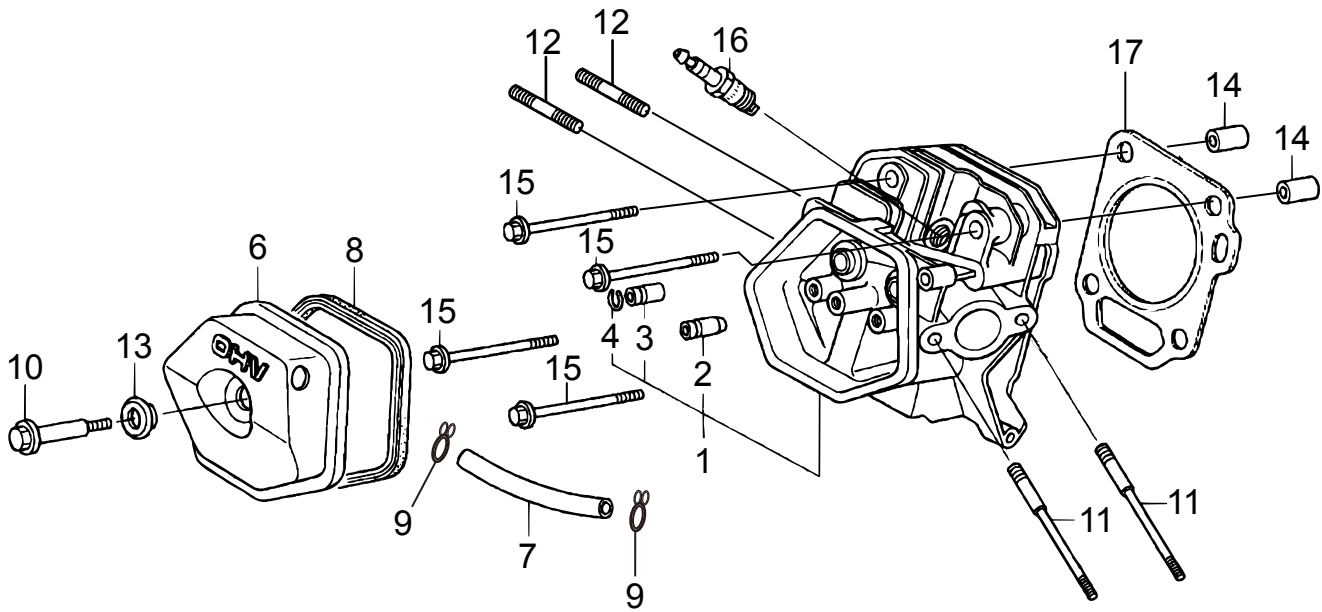

## HONDA GX240UT2SMXC ENGINE — CYLINDER HEAD ASSY.

<u>NO.</u>	<u>PART NO.</u>	<u>PART NAME</u>	<u>QTY.</u>	<u>REMARKS</u>
1	12210Z5K405	HEAD, COMPLETE CYLINDER .....	1.....	INCLUDES ITEMS W/\$
2\$	12204ZE2306	GUIDE, IN.VALVE (OVERSIZE)	1	
3\$	12205ZE2305	GUIDE, EX.VALVE (OVERSIZE)	1	
4\$	12216ZE2300	CLIP, VALVE GUIDE	1	
6	12310ZE3791	COVER COMP., HEAD	1	
7	12315ZE3840	TUBE, BREATHER	1	
8	12391ZE2020	PACKING, HEAD COVER	1	
9	17316611000	CLIP, BREATHER TUBE	2	
10	90014Z5T000	BOLT, HEAD COVER	1	
11	90042ZE2000	BOLT, STUD 8X123	2	
12	92900080320E	BOLT, STUD 8X32	2	
13	90441ZE2010	WASHER COMP., HEAD COVER	1	
14	9430112200	PIN, DOWEL 12X20	2	
15	957011008000	BOLT, FLANGE	4	
16	9807956855	SPARK PLUG	1	
16	0650140480	SPARK PLUG	1	
17	12251Z5K003	GASKET, CYLINDER HEAD	1	

# HONDA GX240UT2SMXC ENGINE — CYL. BARREL ASSY.

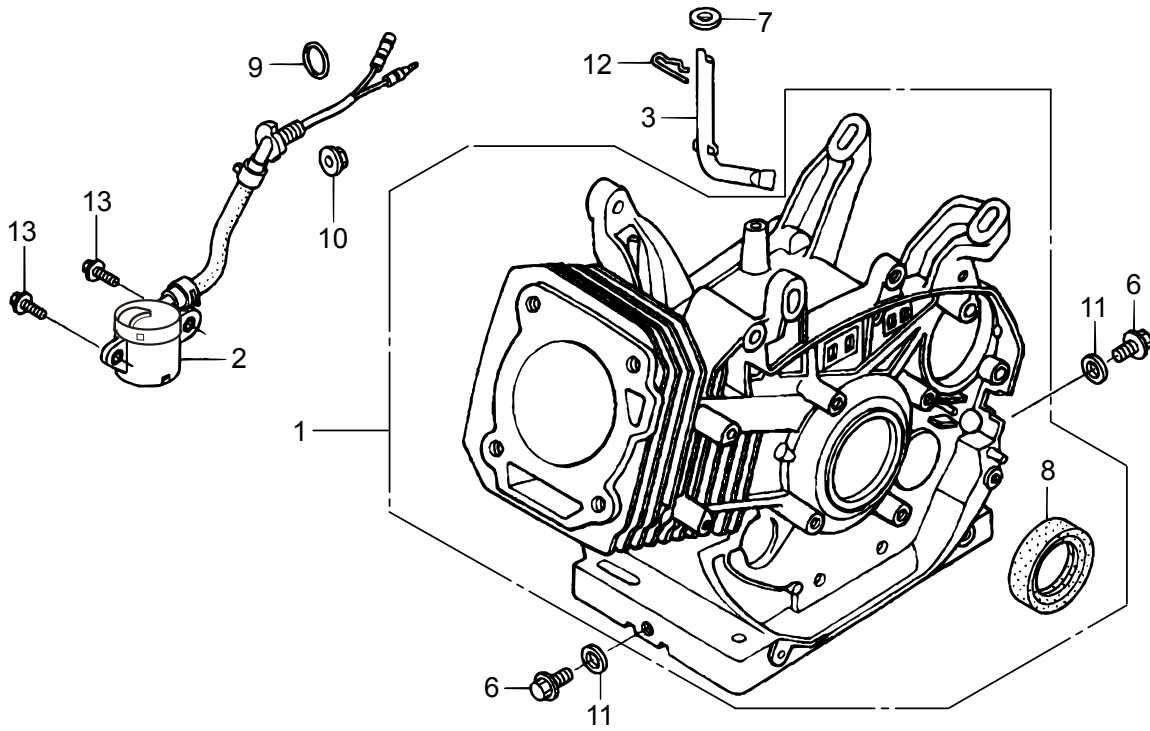

## HONDA GX240UT2SMXC ENGINE — CYL. BARREL ASSY.

<u>NO.</u>	<u>PART NO.</u>	<u>PART NAME</u>	<u>QTY.</u>	<u>REMARKS</u>
1	12000Z5K406	BARREL, ASSY., CYLINDER .....	1.....	INCLUDES ITEMS W/\$
2	35480ZF6003	SWITCH ASSY., OIL LEVEL	1	
3	16541ZE2010	SHAFT, GOVERNOR ARM	1	
6	90013883000	FLANGE BOLT, 6X12	2	
7	90446KE1000	WASHER, 8.2X17X0.8	1	
8\$	91201Z1D003	OIL SEAL, 30X46X8	1	
9	91353671003	O-RING, 14MM .....	1.....	REPLACES P/N 91353671004
10	9405010000	FLANGE NUT M10	1	
11	031112230	WASHER, DRAIN PLUG M12 .....	2.....	REPLACES P/N 9410912000
12	9425110000	PIN, LOCK 10MM	1	
13	957010601200	FLANGE BOLT 6X12	2	

# HONDA GX240UT2SMXC ENGINE — CRANKCASE COVER ASSY.

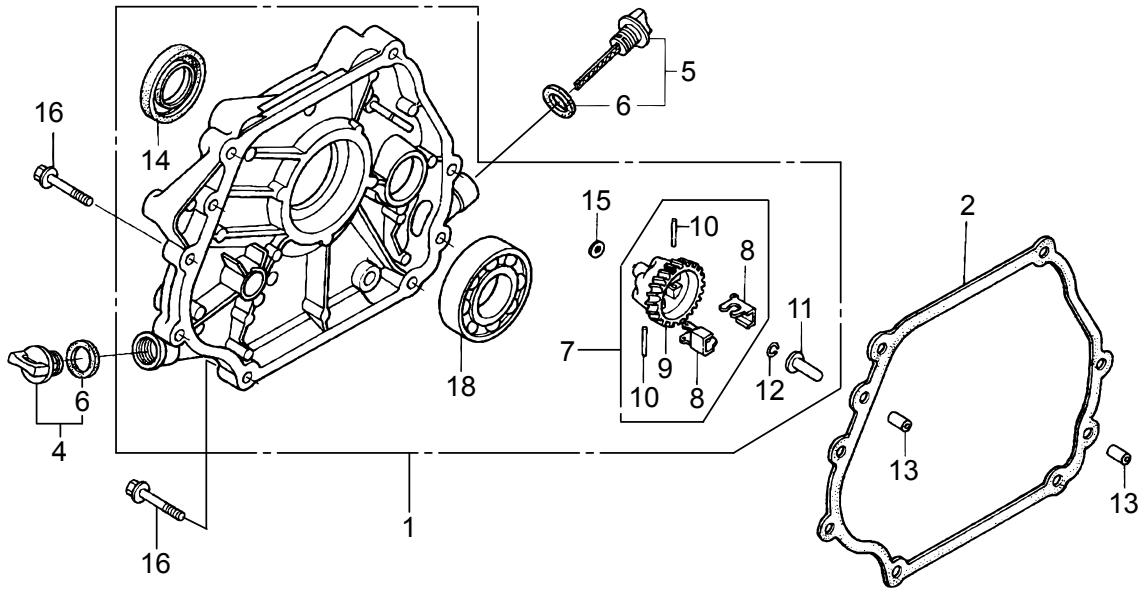



## HONDA GX240UT2SMXC ENGINE — CRANKCASE COVER ASSY.

<u>NO.</u>	<u>PART NO.</u>	<u>PART NAME</u>	<u>QTY.</u>	<u>REMARKS</u>
1	11300Z1D810	COVER ASSY., CRANKCASE.....	1.....	INCLUDES ITEMS W/\$
2	11381Z5K000	PACKING, CASE COVER	1	
4	15600Z0T820	CAP ASSY., OIL FILLER .....	1.....	INCLUDES ITEMS W/%
5	15600Z1C000	CAP ASSY., OIL FILLER .....	1.....	INCLUDES ITEMS W/+
6%+	15625Z0T800	PACKING, OIL FILLER CAP	2	
7\$	16510ZE2000	GOVERNOR ASSY.....	1.....	INCLUDES ITEMS W/#
8\$#	16511ZE2000	WEIGHT, GOVERNOR	2	
9\$#	16512ZE2000	HOLDER, GOVERNOR WEIGHT	1	
10\$#	16513ZE2000	PIN, GOVERNOR WEIGHT	2	
11\$	16531Z0A000	SLIDER, GOVERNOR	1	
12\$	90602ZE1000	CLIP, GOVERNOR HOLDER	1	
13	90701HC4000	PIN, DOWEL 8X12	2	
14\$	91201Z1D003	OIL SEAL 30X46X8	1	
15\$	94010106800	WASHER, FLAT, 6MM	1	
16	957010803500	FLANGE BOLT 8X35	7	
18\$	961006206000	BALL BEARING	1	

# HONDA GX240UT2SMXC ENGINE — CRANKSHAFT ASSY.

---

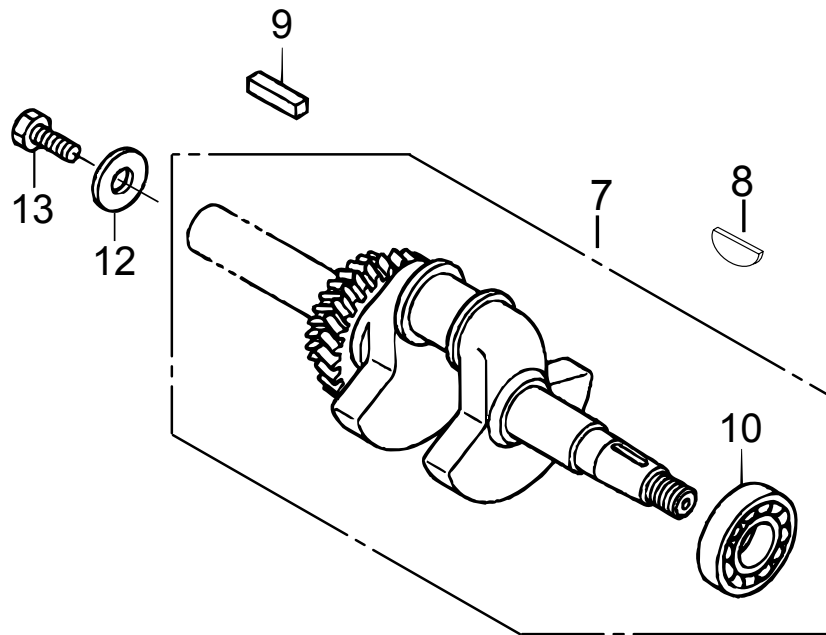

# HONDA GX240UT2SMXC ENGINE — CRANKSHAFT ASSY.

---

<u>NO.</u>	<u>PART NO.</u>	<u>PART NAME</u>	<u>QTY.</u>	<u>REMARKS</u>
7	13310ZH9010	CRANKSHAFT COMPLETE.....	1.....	INCLUDES ITEMS W/#
8	90741ZE2000	KEY, SPECIAL WOODRUFF 25X18	1	
9	90741889810	KEY 7X7X33.....	1.....	REPLACES P/N 951400520
10#	91001ZH9003	BEARING, BALL	1	
12	030208200	WASHER, LOCK M8	1	
13	011208030	BOLT 8X30.....	1.....	REPLACES P/N 001220830

# HONDA GX240UT2SMXC ENGINE — PISTON ASSY.

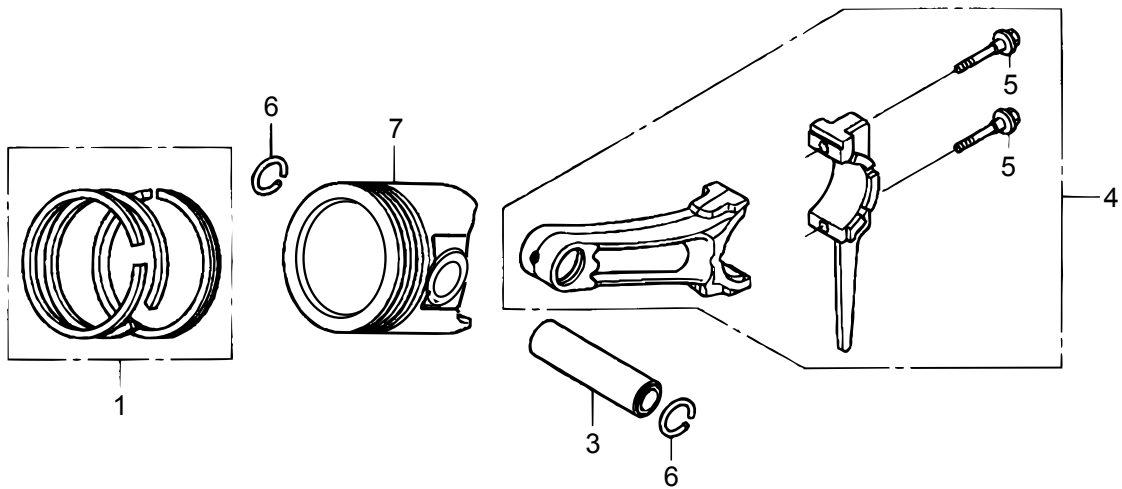

## HONDA GX240UT2SMXC ENGINE — PISTON ASSY.

<u>NO.</u>	<u>PART NO.</u>	<u>PART NAME</u>	<u>QTY.</u>	<u>REMARKS</u>
1	13010Z5K004	RING SET, PISTON (STD)	1	
1	13011Z5K004	RING SET, PISTON 0.25 OS	1	
1	13012Z5K004	RING SET, PISTON 0.50 OS	1	
1	13013Z5K004	RING SET, PISTON 0.75 OS	1	
3	13111Z5K000	PIN, PISTON	1	
4	13200Z1D305	ROD ASSY., CONNECTING/0.25UN.....	1	INCLUDES ITEM W/\$
4	13200Z1D900	ROD ASSY., CONNECTING (STD) .....	1	INCLUDES ITEM W/\$
5\$	90001ZE8000	BOLT, CONNECTING ROD	2	
6	90551ZE1000	CLIP, PISTON PIN 18MM	2	
7	13101Z1D900	PISTON (STD)	1	
7	13102Z5K000	PISTON (0.25 OS)	1	
7	13103Z5K000	PISTON (0.50 OS)	1	
7	13104Z5K000	PISTON (0.75 OS)	1	

# HONDA GX240UT2SMXC ENGINE — CAMSHAFT ASSY.

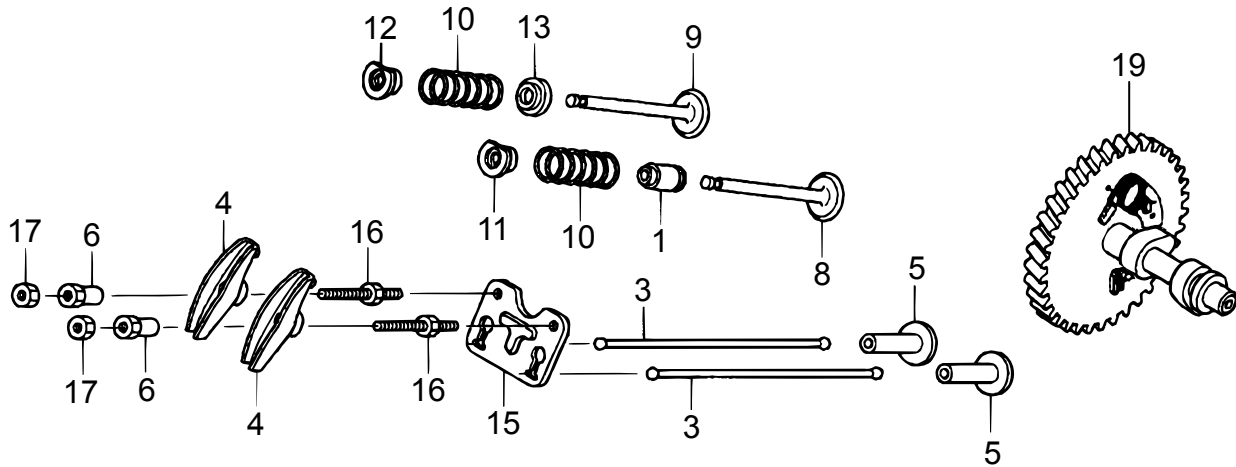

## HONDA GX240UT2SMXC ENGINE — CAMSHAFT ASSY.

---

<u>NO.</u>	<u>PART NO.</u>	<u>PART NAME</u>	<u>QTY.</u>	<u>REMARKS</u>
1	12209ZE8003	SEAL, VALVE STEM	1	
3	14410Z1D000	ROD, PUSH	2	
4	14431ZE2010	ARM, VALVE ROCKER	2	
5	14441ZE2000	LIFTER, VALVE	2	
6	14451ZE1013	PIVOT, ROCKER ARM	2	
8	14711Z5K900	VALVE, IN.	1	
9	14721Z5K900	VALVE, EX	1	
10	14751Z1C000	SPRING, VALVE	2	
11	14771Z8S000	RETAINER, VALVE SPRING	1	
12	14771Z8S000	RETAINER, VALVE SPRING	1	
13	14775ZE2010	SEAT, VALVE SPRING	1	
15	14791Z1D000	PLATE, PUSH ROD GUIDE	1	
16	90012ZE0010	BOLT, PIVOT, 8MM	1	
17	90206ZE1000	NUT, PIVOT ADJUSTING	2	
19	14100Z5K910	CAMSHAFT CP/STD/PRESS FIT	1	

# HONDA GX240UT2SMXC ENGINE — RECOIL STARTER ASSY.

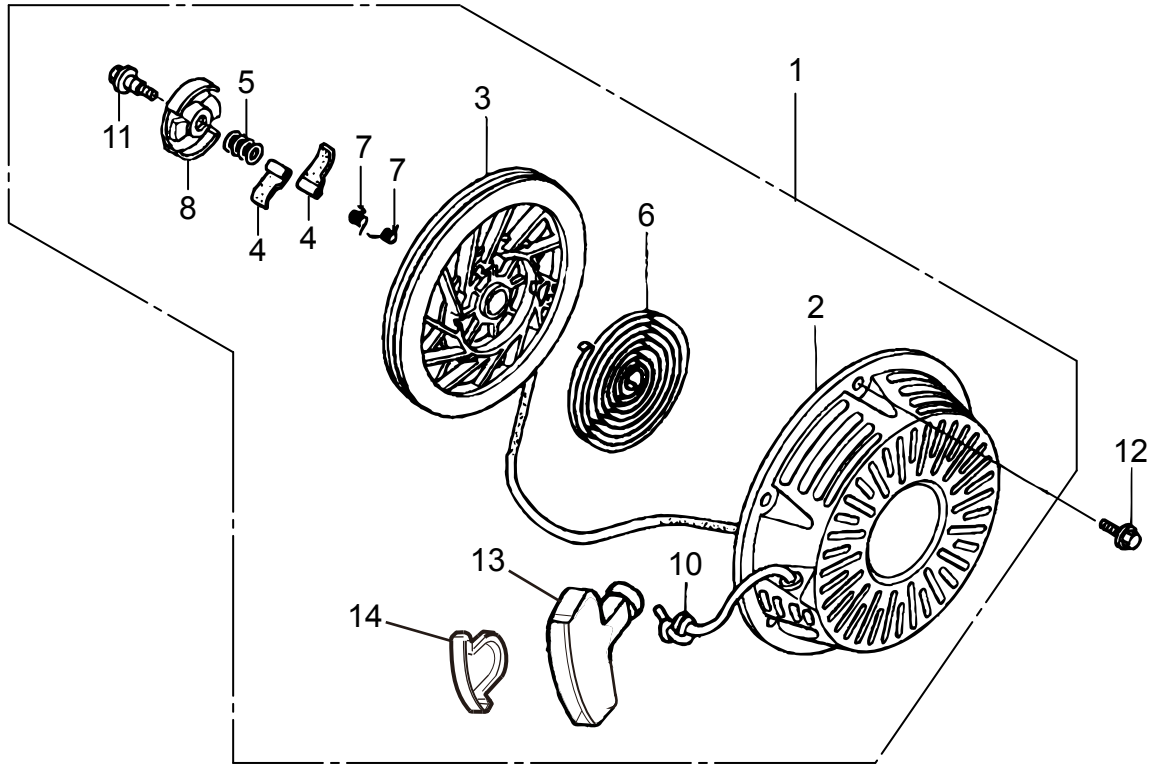



## **HONDA GX240UT2SMXC ENGINE — RECOIL STARTER ASSY.**

---

<b><u>NO.</u></b>	<b><u>PART NO.</u></b>	<b><u>PART NAME</u></b>	<b><u>QTY.</u></b>	<b><u>REMARKS</u></b>
1	28400Z5K305ZB	RECOIL STARTER ASSY. ....	1.....	INCLUDES ITEMS W/\$
2\$	28410ZE2W01ZB	CASE COMPLETE, RECOIL STARTER	1	
3\$	28421ZE2W01	PULLEY, RECOIL STARTER	1	
4\$	28422ZE2W01	RATCHET, STARTER	2	
5\$	28441ZE2W01	SPRING, FRICTION	1	
6\$	28442ZE2W01	SPRING, STARTER RETURN	1	
7\$	28443ZE2W01	SPRING, RATCHET	2	
8\$	28444ZE2W01	RETAINER, SPRING	1	
10\$	28462ZE2W11	ROPE, RECOIL STARTER	1	
11\$	90004ZE2W01	SCREW, CENTER	1	
12	957010601000	BOLT FLANGE 6X10	3	
13\$	28461Z5T305	GRIP, STARTER	1	
14\$	28463Z5T013	GRIP, REINFORCEMENT	1	

**HONDA GX240UT2SMXC ENGINE — FAN COVER ASSY.**

---

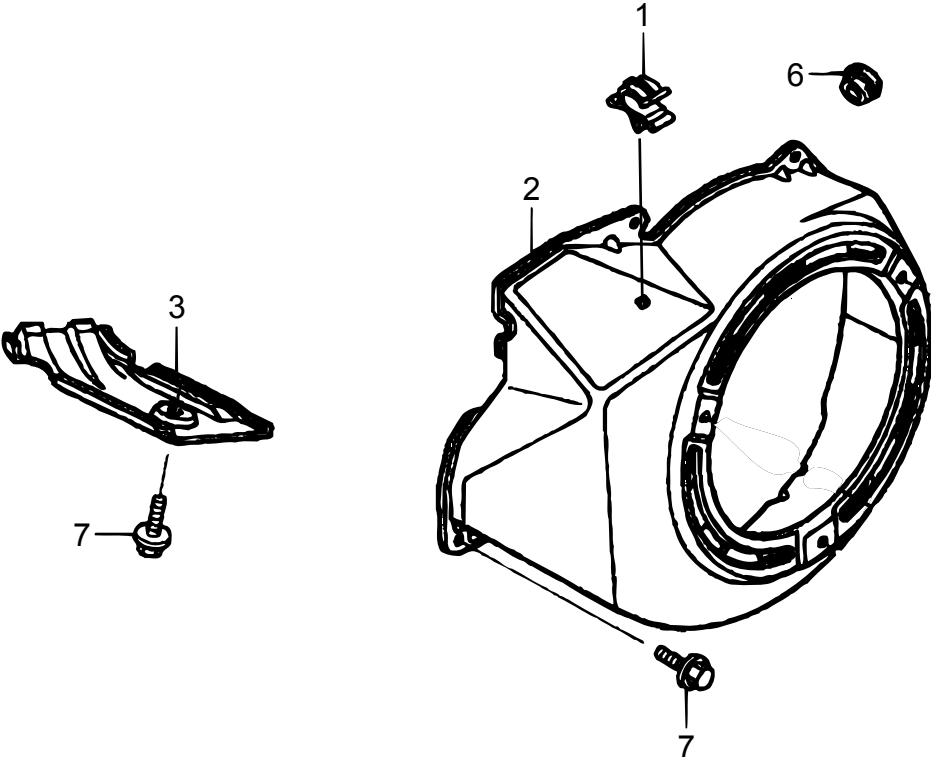

## HONDA GX240UT2SMXC ENGINE — FAN COVER ASSY.

---

<u>NO.</u>	<u>PART NO.</u>	<u>PART NAME</u>	<u>QTY.</u>	<u>REMARKS</u>
1	16731ZE2003	CLIP, TUBE	1	
2	19610Z5K000ZA	COVER, COMPLETE FAN	1	
3	19631Z5K000	SHROUD	1	
6	81329567020	GROMMET, DRAIN HOLE	1	
7	90013883000	FLANGE BOLT 6X12	6	

# HONDA GX240UT2SMXC ENGINE — CARBURETOR ASSY.

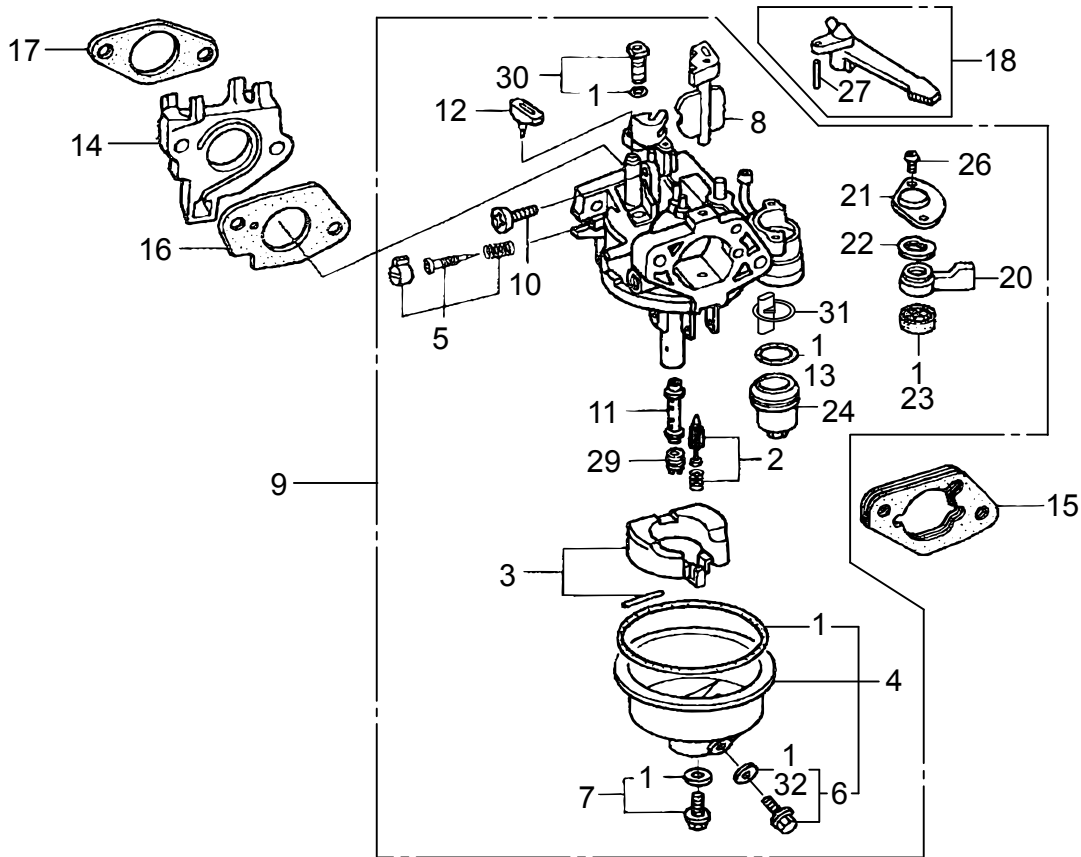

## NOTICE

Gasket set, item 1 included with items 6, 7, 13, 23, 30 and 32..

## HONDA GX240UT2SMXC ENGINE — CARBURETOR ASSY.

<u>NO.</u>	<u>PART NO.</u>	<u>PART NAME</u>	<u>QTY.</u>	<u>REMARKS</u>
1#	16010ZE2812	GASKET SET	1	
2#	16011ZA0931	VALVE SET, FLOAT	1	
3#	16013Z1C003	FLOAT SET	1	
4#	16015Z5T901	CHAMBER SET, FLOAT	1	
5#	16016ZH7W01	SCREW SET, PILOT	1	
6#	16024Z5T901	SCREW SET, DRAIN	1	
7#	16028Z5T901	SCREW SET	1	
8#	16044ZE2005	CHOKE SET	1	
9	16100Z8S902	CARBURETOR ASSY.....	1	INCLUDES ITEMS W/#
10#	16124ZE0005	SCREW, THROTTLE STOP	1	
11#	16166Z8S901	NOZZLE, MAIN	1	
12#	16172ZE3W10	COLLAR SET	1	
13#	16955283000	PACKING, CUP.....	1	REPLACES P/N 16173001004
14	16211ZE2010	INSULATOR, CARBURETOR	1	
15	16220ZA0702	SPACER COMP., CARBURETOR	1	
16	16221Z5K000	PACKING, CARBURETOR	1	
17	16212Z5K000	PACKING, INSULATOR	1	
18	16610ZE1000	CHOKE LEVER COMPLETE .....	1	INCLUDES ITEMS W/\$
20#	16953ZE1812	LEVER, COCK	1	
21#	16954ZE1812	PLATE, LEVER SETTING	1	
22#	16956ZE1811	SPRING, COCK LEVER	1	
23#	16957ZE1812	PACKING, FUEL COCK	1	
24#	16967ZE0811	CUP, FUEL STRAINER	1	
26#	93500030060H	SCREW 3X6 .....	2	REPLACES P/N 93500030061H
27\$	9430520122	SPRING PIN 2X12	1	
29#	99101ZH80980	JET, MAIN #98	1	
30#	99204ZE20380	JET SET, PILOT, #38	1	
31#	16959Z5T901	FILTER, CUP	1	
32#	16141Z0S003	WASHER, FLAT	1	

# HONDA GX240UT2SMXC ENGINE — AIR CLEANER ASSY.

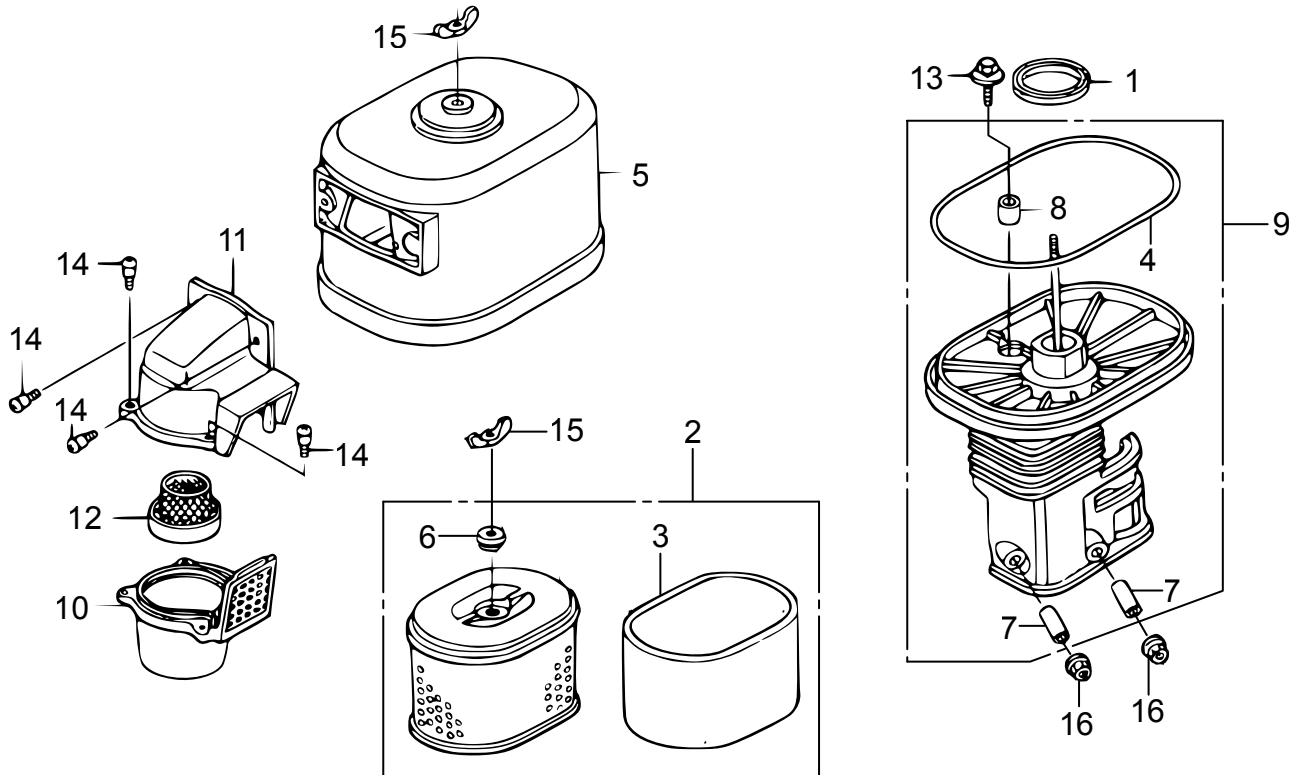

## HONDA GX240UT2SMXC ENGINE — AIR CLEANER ASSY.

<u>NO.</u>	<u>PART NO.</u>	<u>PART NAME</u>	<u>QTY.</u>	<u>REMARKS</u>
1	16271ZE2010	PACKING, ELBOW	1	
2	17210ZE3505	ELEMENT, AIR CLEANER .....	1.....	REPLACES P/N 17210ZE3010 INCLUDES ITEMS W/#
3#	17218ZE3505	FILTER, OUTER .....	1.....	REPLACES P/N 17218ZE3000
4\$	17219HA2405	PACKING, AIR CLEANER COVER.....	1.....	REPLACES P/N 17219ZE3840
5	17230ZE3841	COVER COMPLETE, AIR CLEANER	1	
6#	17232891000	GROMMET, AIR CLEANER	1	
7\$	17238ZE2310	COLLAR, AIR CLEANER	2	
8\$	17239ZE3840	COLLAR B, AIR CLEANER	1	
9	17410ZE3841	ELBOW COMPLETE AIR CLEANER.....	1.....	INCLUDES ITEMS W/\$
10	17470ZE3842	CASE COMPLETE, PRE AIR CLEANER	1	
11	17475ZE3841	CAP, PRE AIR CLEANER	1	
12	17476ZE3841	GUIDE, PRE AIR CLEANER	1	
13	90009Z1C000	BOLT-WASHER 6X22	1	
14	90142MB0000	SCREW, PAN 5X16.5	5	
15	90325044000	NUT, TOOL BOX SETTING	2	
16	9405006000	FLANGE, NUT 6MM	2	

# HONDA GX240UT2SMXC ENGINE — MUFFLER ASSY.

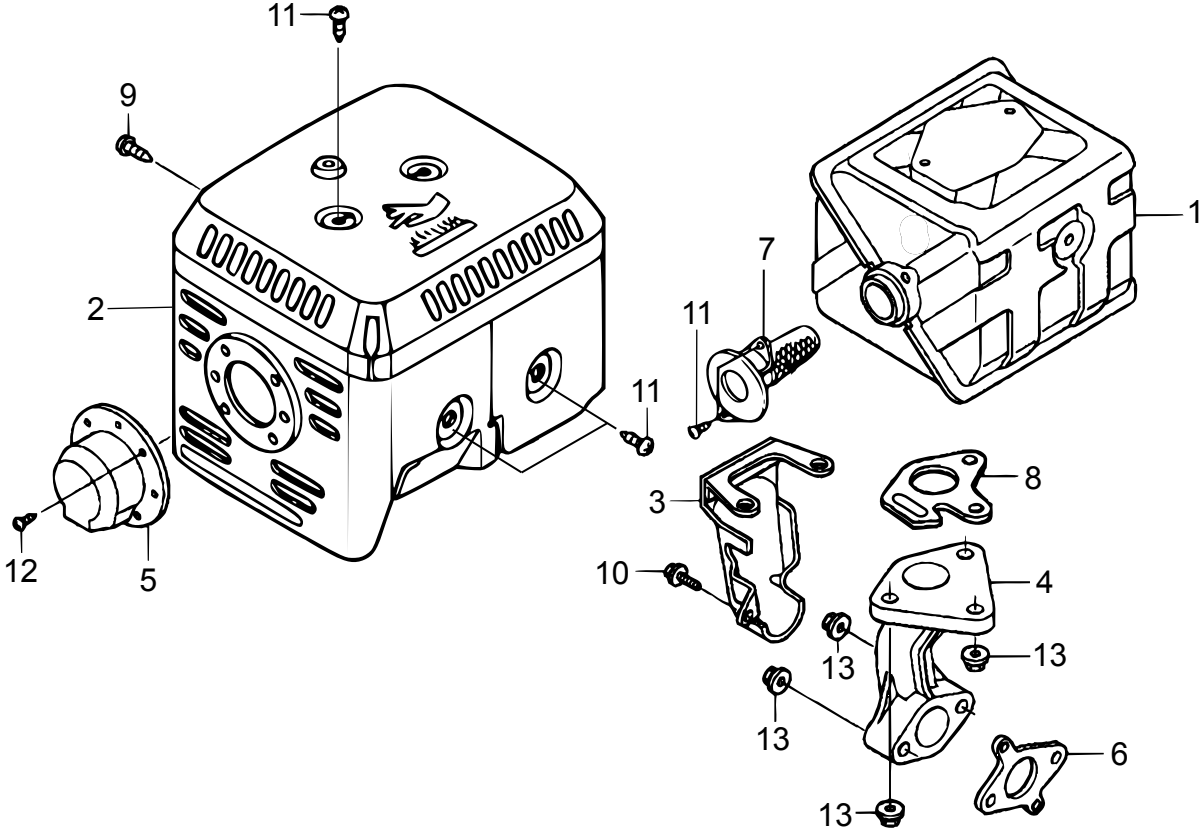



## HONDA GX240UT2SMXC ENGINE — MUFFLER ASSY.

---

<u>NO.</u>	<u>PART NO.</u>	<u>PART NAME</u>	<u>QTY.</u>	<u>REMARKS</u>
1	18310Z5K010	MUFFLER COMP.	1	
2	18320Z5K000	PROTECTOR COMPLETE, MUFFLER	1	
3	18323ZE2W00	PROTECTOR, EXHAUST PIPE	1	
4	18331Z5T000	PIPE, EX	1	
5	18331ZE3811	CAP, MUFFLER	1	
6	18333Z1C801	GASKET, EX. PIPE	1	
7	18350Z5T800	ARRESTER COMPLETE, SPARK	1	
8	18381Z8S801	GASKET, MUFFLER (ARRESTER)	1	
9	90006ZE2000	TAPPING SCREW 6X10	1	
10	90013883000	FLANGE BOLT 6X12	1	
11	90050ZE1000	TAPPING SCREW 5X8	8	
12	90055ZE1000	TAPPING SCREW 4X6	3	
13	9405008000	FLANGE NUT M8	5	

# HONDA GX240UT2SMXC ENGINE — FUEL TANK ASSY.

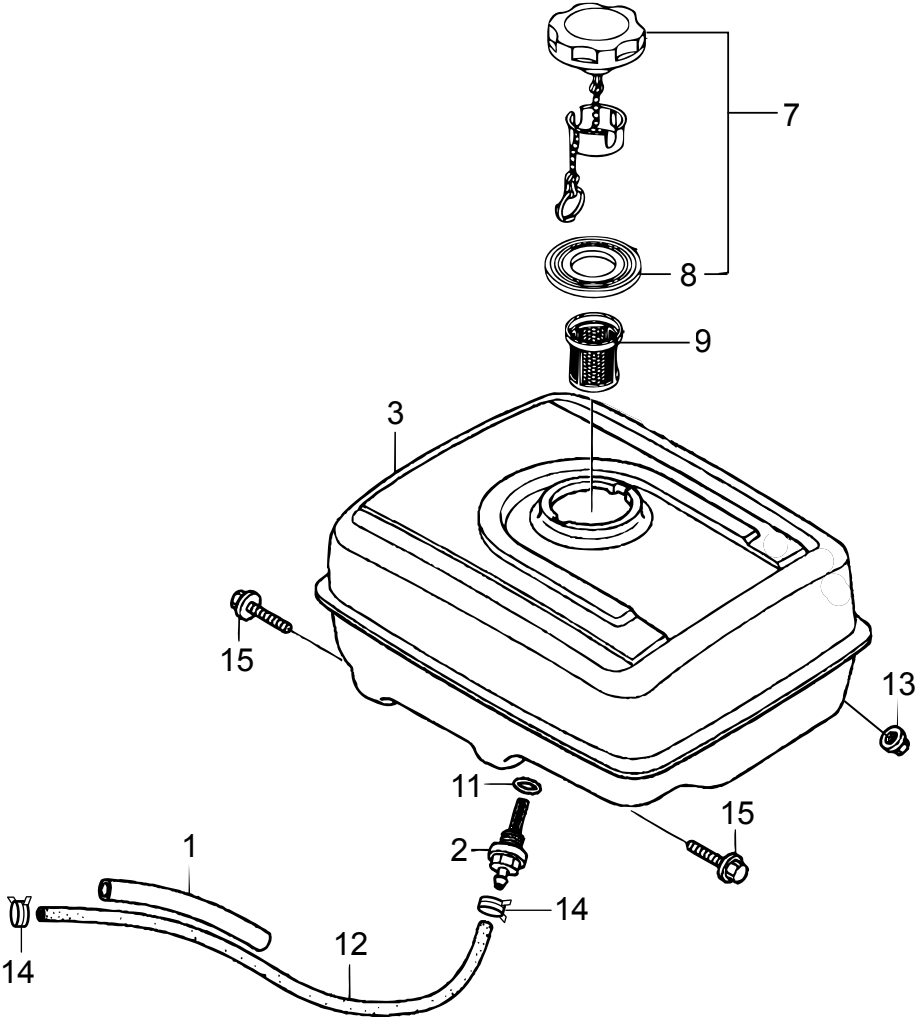

## HONDA GX240UT2SMXC ENGINE — FUEL TANK ASSY.

<u>NO.</u>	<u>PART NO.</u>	<u>PART NAME</u>	<u>QTY.</u>	<u>REMARKS</u>
1	16854ZH8000	RUBBER, SUPPORT (107MM)	1	
2	16955ZE1010	JOINT, FUEL TANK	1	
3	17510Z5K000ZA	TANK, COMPLETE FUEL	1	
7	17620Z4H900	FUEL TANK CAP COMPLETE.....	1.....	INCLUDES ITEM W/\$
8\$	17631Z0T801	PACKING, FUEL FILLER CAP	1	
9	17672Z4H000	FILTER, FUEL	1	
11	91353671003	O-RING 14MM.....	1.....	REPLACES P/N 91353671004
12	91424Z5K003	TUBE, FUEL 4.5X210	1	
13	9405008000	FLANGE NUT M8	2	
14	950024080008	CLAMP, TUBE	2	
15	957010802500	FLANGE BOLT 8X25	2	

# HONDA GX240UT2SMXC ENGINE — FLYWHEEL ASSY.

---

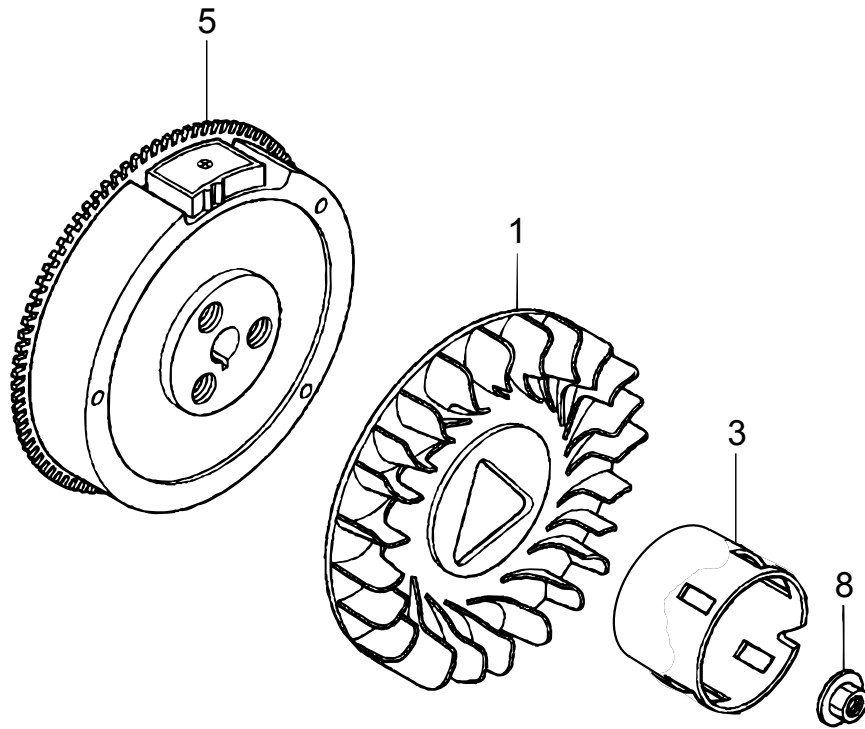

## HONDA GX240UT2SMXC ENGINE — FLYWHEEL ASSY.

---

<u>NO.</u>	<u>PART NO.</u>	<u>PART NAME</u>	<u>QTY.</u>	<u>REMARKS</u>
1	19511ZE2000	FAN, COOLING	1	
3	28451ZE2W01	PULLEY, STARTER	1	
5	31110Z5K000	FLYWHEEL, COMPLETE	1	
8	90201ZE3V00	NUT, SPECIAL 16MM	1	

# HONDA GX240UT2SMXC ENGINE — IGNITION COIL ASSY.

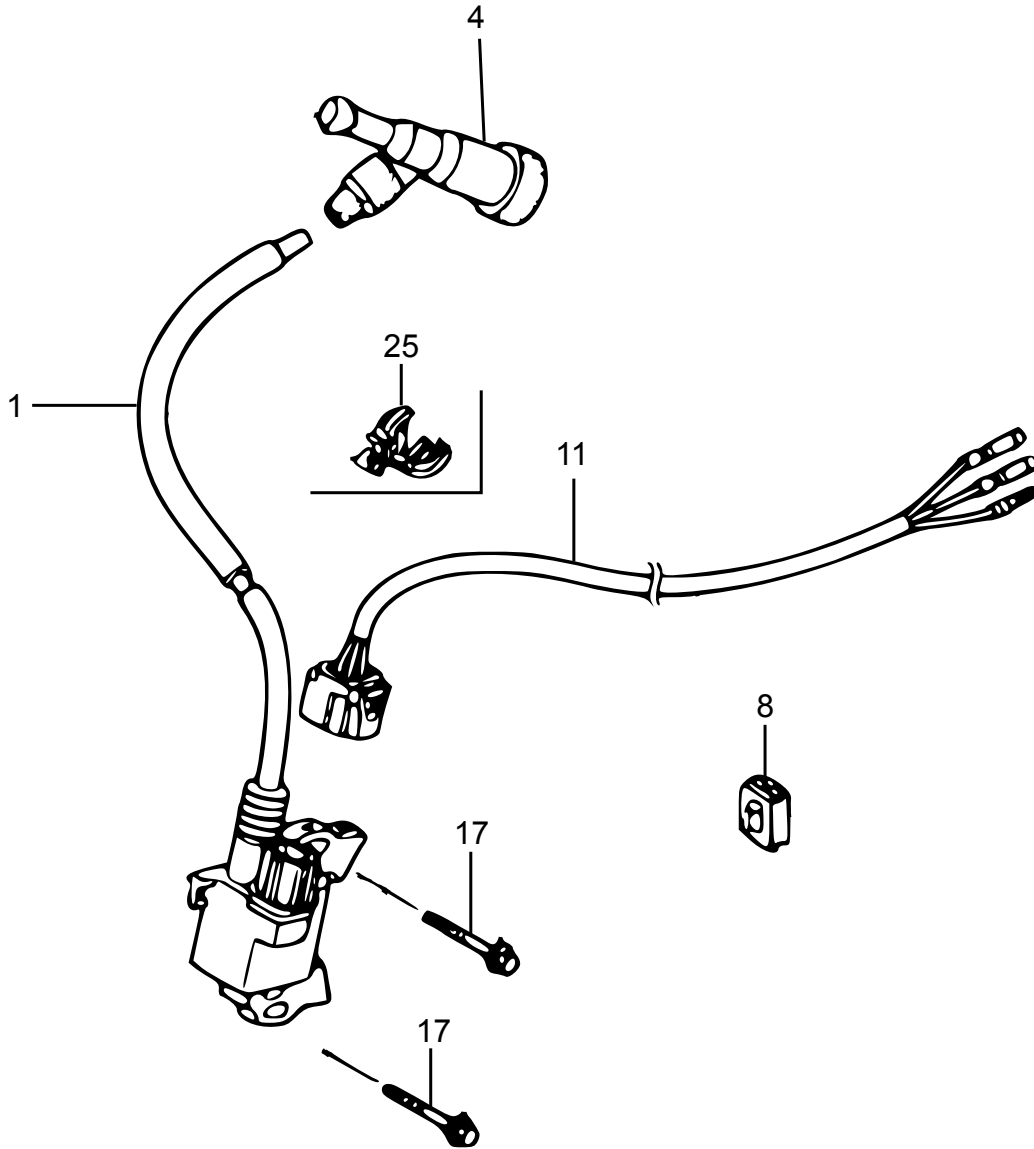

# HONDA GX240UT2SMXC ENGINE — IGNITION COIL ASSY.

---

<u>NO.</u>	<u>PART NO.</u>	<u>PART NAME</u>	<u>QTY.</u>	<u>REMARKS</u>
1	30500Z8S003	COIL ASSY., IGNITION	1	
4	30700Z1C811	CAP ASSY., NOISE SUPPRESSOR	1	
8	31512ZE2000	GROMMET, CORD	1	
11	32110Z5K000	HARNESS ASSY., E/G WIRE	1	
17	90015883000	FLANGE BOLT 6X28	2	
25	90684ZA0601	CLIP, HARNESS	1	

# HONDA GX240UT2SMXC ENGINE — CONTROL ASSY.

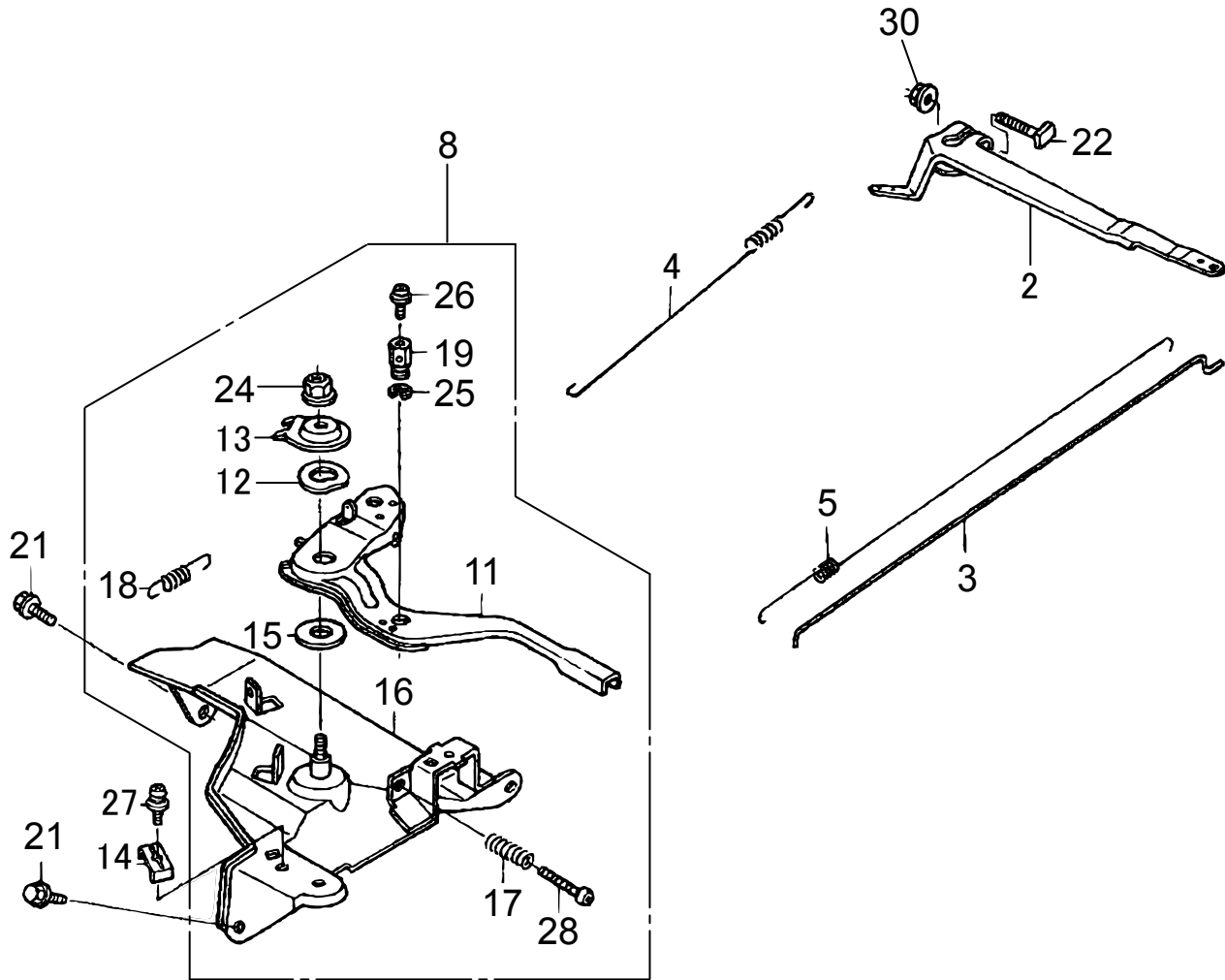



## HONDA GX240UT2SMXC ENGINE — CONTROL ASSY.

<u>NO.</u>	<u>PART NO.</u>	<u>PART NAME</u>	<u>QTY.</u>	<u>REMARKS</u>
2	16551ZE2000	ARM, GOVERNOR	1	
3	16555ZE2000	ROD, GOVERNOR	1	
4	16561ZE2000	SPRING, GOVERNOR	1	
5	16562ZE2000	SPRING, THROTTLE RETURN	1	
8	16500Z5K308	CONTROL ASSY. (REMOTE).....	1.....	INCLUDES ITEMS W/#
11#	16571ZE2W00	LEVER, CONTROL	1	
12#	16574ZE1000	LEVER SPRING	1	
13#	16575ZE2W00	WASHER, CONTROL LEVER	1	
14	16576891000	HOLDER, CABLE	1	
15#	16578ZE1000	SPACER, CONTROL LEVER	1	
16#	16580Z5K000	BASE COMP., CONTROL	1	
17#	16584883300	ADJUSTING SPRING	1	
18#	16592883310	SPRING, CABLE RETURN	1	
19#	16594883010	HOLDER, WIRE	1	
21	90013883000	FLANGE BOLT 6X12	2	
22	90015Z5T000	BOLT, GOVERNOR ARM	1	
24#	90114SA0000	LOCK NUT 6MM	1	
25#	90605230000	CIR CLIP	1	
26#	0043504060	SCREW 4X6 .....	1.....	REPLACES P/N 93500040060H
27	0202005T125	SCREW 5X16 .....	1.....	REPLACES P/N 93500050160A
28#	93500050280A	SCREW, PAN 5X28	1	
30	9405006000	FLANGE NUT 6MM	1	

# HONDA GX240UT2SMXC ENGINE — LABELS ASSY.

---

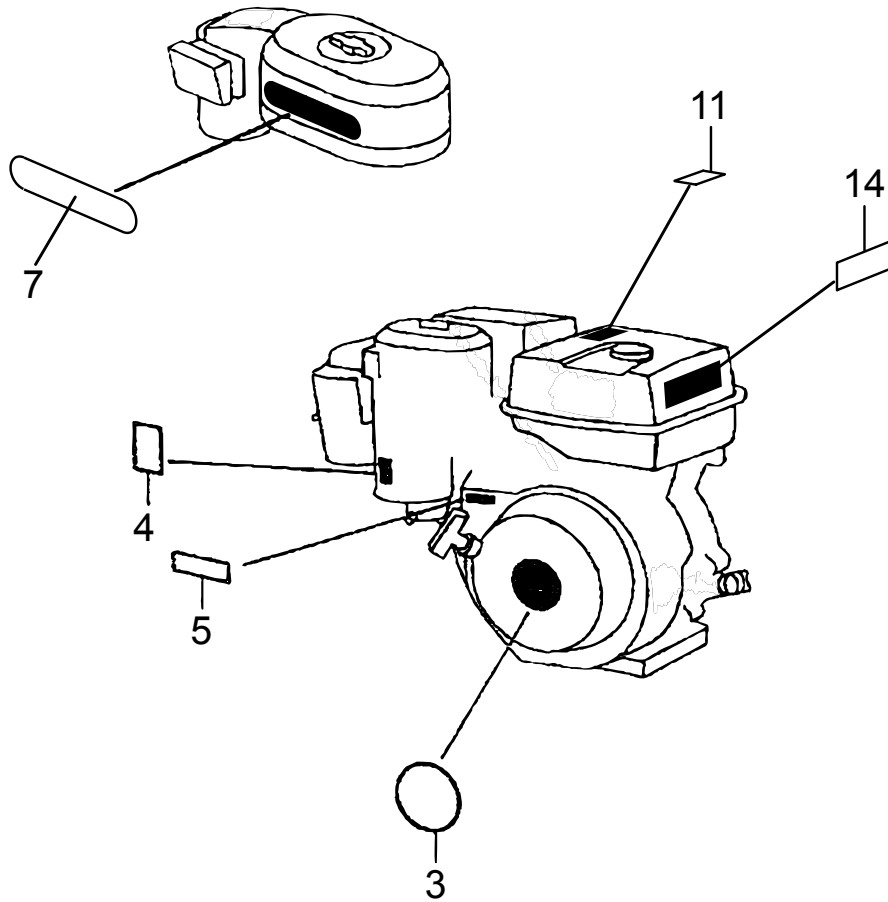

## HONDA GX240UT2SMXC ENGINE — LABELS ASSY.

---

<u>NO.</u>	<u>PART NO.</u>	<u>PART NAME</u>	<u>QTY.</u>	<u>REMARKS</u>
3	87521Z8S000	LABEL, EMBLEM	1	
4	87528Z5T000	MARK, CHOKE (GRAY)	1	
5	87532ZH7000	MARK, THROTTLE INDICATION	1	
7	87535ZE1841	MARK, AIR CLEANER	1	
11	87539Z0J000	MARK, EX. CAUTION (ENGLISH)	1	
14	87516Z4H010	MARK, OP-CAUTION (ENGLISH)	1	

# TERMS AND CONDITIONS OF SALE — PARTS

## PAYMENT TERMS

Terms of payment for parts are net 30 days.

## FREIGHT POLICY

All parts orders will be shipped collect or prepaid with the charges added to the invoice. All shipments are F.O.B. point of origin. Multiquip's responsibility ceases when a signed manifest has been obtained from the carrier, and any claim for shortage or damage must be settled between the consignee and the carrier.

## MINIMUM ORDER

The minimum charge for orders from Multiquip is \$15.00 net. Customers will be asked for instructions regarding handling of orders not meeting this requirement.

## RETURNED GOODS POLICY

Return shipments will be accepted and credit will be allowed, subject to the following provisions:

1. A Returned Material Authorization must be approved by Multiquip prior to shipment.
2. To obtain a Return Material Authorization, a list must be provided to Multiquip Parts Sales that defines item numbers, quantities, and descriptions of the items to be returned.
  - a. The parts numbers and descriptions must match the current parts price list.
  - b. The list must be typed or computer generated.
  - c. The list must state the reason(s) for the return.
  - d. The list must reference the sales order(s) or invoice(s) under which the items were originally purchased.
  - e. The list must include the name and phone number of the person requesting the RMA.
3. A copy of the Return Material Authorization must accompany the return shipment.
4. Freight is at the sender's expense. All parts must be returned freight prepaid to Multiquip's designated receiving point.

5. Parts must be in new and resalable condition, in the original Multiquip package (if any), and with Multiquip part numbers clearly marked.
6. The following items are not returnable:
  - a. Obsolete parts. (If an item is in the price book and shows as being replaced by another item, it is obsolete.)
  - b. Any parts with a limited shelf life (such as gaskets, seals, "O" rings, and other rubber parts) that were purchased more than six months prior to the return date.
  - c. Any line item with an extended dealer net price of less than \$5.00.
  - d. Special order items.
  - e. Electrical components.
  - f. Paint, chemicals, and lubricants.
  - g. Decals and paper products.
  - h. Items purchased in kits.
7. The sender will be notified of any material received that is not acceptable.
8. Such material will be held for five working days from notification, pending instructions. If a reply is not received within five days, the material will be returned to the sender at his expense.
9. Credit on returned parts will be issued at dealer net price at time of the original purchase, less a 15% restocking charge.
10. In cases where an item is accepted, for which the original purchase document can not be determined, the price will be based on the list price that was effective twelve months prior to the RMA date.
11. Credit issued will be applied to future purchases only.

## PRICING AND REBATES

Prices are subject to change without prior notice. Price changes are effective on a specific date and all orders received on or after that date will be billed at the revised price. Rebates for price declines and added charges for price increases will not be made for stock on hand at the time of any price change.

Multiquip reserves the right to quote and sell direct to Government agencies, and to Original Equipment Manufacturer accounts who use our products as integral parts of their own products.

## SPECIAL EXPEDITING SERVICE

A \$35.00 surcharge will be added to the invoice for special handling including bus shipments, insured parcel post or in cases where Multiquip must personally deliver the parts to the carrier.

## LIMITATIONS OF SELLER'S LIABILITY

Multiquip shall not be liable hereunder for damages in excess of the purchase price of the item with respect to which damages are claimed, and in no event shall Multiquip be liable for loss of profit or good will or for any other special, consequential or incidental damages.

## LIMITATION OF WARRANTIES

No warranties, express or implied, are made in connection with the sale of parts or trade accessories nor as to any engine not manufactured by Multiquip. Such warranties made in connection with the sale of new, complete units are made exclusively by a statement of warranty packaged with such units, and Multiquip neither assumes nor authorizes any person to assume for it any other obligation or liability whatever in connection with the sale of its products. Apart from such written statement of warranty, there are no warranties, express, implied or statutory, which extend beyond the description of the products on the face hereof.

Effective: February 22, 2006



# OPERATION AND PARTS MANUAL

## HERE'S HOW TO GET HELP

PLEASE HAVE THE MODEL AND SERIAL  
NUMBER ON-HAND WHEN CALLING

### UNITED STATES

#### ***Multiquip Corporate Office***

18910 Wilmington Ave.  
Carson, CA 90746  
Contact: mq@multiquip.com

Tel. (800) 421-1244  
Fax (310) 537-3927

#### ***Service Department***

800-421-1244  
310-537-3700

Fax: 310-537-4259

#### ***Technical Assistance***

800-478-1244

Fax: 310-943-2238

#### ***MQ Parts Department***

800-427-1244  
310-537-3700

Fax: 800-672-7877  
Fax: 310-637-3284

#### ***Warranty Department***

800-421-1244  
310-537-3700

Fax: 310-943-2249

### CANADA

#### ***Multiquip***

4110 Industriel Boul.  
Laval, Quebec, Canada H7L 6V3  
Contact: infocanda@multiquip.com

Tel: (450) 625-2244  
Tel: (877) 963-4411  
Fax: (450) 625-8664

### UNITED KINGDOM

#### ***Multiquip (UK) Limited Head Office***

Unit 2, Northpoint Industrial Estate,  
Globe Lane,  
Dukinfield, Cheshire SK16 4UJ  
Contact: sales@multiquip.co.uk

Tel: 0161 339 2223  
Fax: 0161 339 3226

© COPYRIGHT 2016, MULTIQUIP INC.

Multiquip Inc, the MQ logo and the Mikasa logo are registered trademarks of Multiquip Inc. and may not be used, reproduced, or altered without written permission. All other trademarks are the property of their respective owners and used with permission.

This manual MUST accompany the equipment at all times. This manual is considered a permanent part of the equipment and should remain with the unit if resold.

The information and specifications included in this publication were in effect at the time of approval for printing. Illustrations, descriptions, references and technical data contained in this manual are for guidance only and may not be considered as binding. Multiquip Inc. reserves the right to discontinue or change specifications, design or the information published in this publication at any time without notice and without incurring any obligations.

Your Local Dealer is:

