

OPERATION AND PARTS MANUAL



Mikasa SERIES
MODEL MVC88VTH
MODEL MVC88VTHW
ONE-WAY PLATE COMPACTOR
(HONDA GX160UT2QMX2/GX160UT2QMXC
GASOLINE ENGINES)

Revision #6 (11/22/16)

To find the latest revision of this
publication, visit our website at:
www.multiquip.com



THIS MANUAL MUST ACCOMPANY THE EQUIPMENT AT ALL TIMES.



CALIFORNIA — Proposition 65 Warning

Gasoline engine exhaust and some of its constituents are known to the State of California to cause cancer, birth defects and other reproductive harm.

TABLE OF CONTENTS

MVC88VTH/MVC88VTHW Forward Plate Compactor

Proposition 65 Warning	2
Table Of Contents	4
Parts Ordering Procedures.....	5
Safety Information	6-10
Specifications	11
Noise And Vibration Emissions.....	12
Dimensions.....	13
General Information.....	14
Compactor Components.....	15-16
Inspection	17-18
Startup.....	19-20
Operation.....	21
Operation/Maintenance	22
Maintenance	23-26
Explanation Of Code In Remarks Column.....	28
Suggested Spare Parts	29

Compactor Component Drawings

Body Assembly	30-33
Vibrator Assembly	34-35
Transport Wheel Assembly (Option).....	36-37
Sprinkler Assembly.....	38-39
Urethane Plate Assembly (Option).....	40-41
Nameplate And Decals Assembly	42-43

Honda GX160UT2QMX2/ GX160UT2QMXC Engine Component Drawings

Cylinder Head Assembly	44-45
Cylinder Barrel Assembly	46-47
Crankcase Cover Assembly	48-49
Crankshaft Assembly.....	50-51
Piston Assembly	52-53
Camshaft Assembly.....	54-55
Recoil Starter Assembly	56-57
Fan Cover Assembly.....	58-59
Carburetor Assembly	60-61
Air Cleaner Assembly (GX160UT2QMX2)	62-63
Air Cleaner Assembly (Gx160UT2QMXC)	64-65
Muffler Assembly	66-67
Fuel Tank Assembly.....	68-69
Flywheel Assembly	70-71
Ignition Coil Assembly.....	72-73
Control Assembly	74-75
Decals Assembly	76-77

Terms and Conditions of Sale — Parts	78
--	----

PARTS ORDERING PROCEDURES

Ordering parts has never been easier! Choose from three easy options:

Effective:
January 1st, 2006

www.multiquip.com



Order via Internet (Dealers Only):

Order parts on-line using Multiquip's SmartEquip website!

- View Parts Diagrams
- Order Parts
- Print Specification Information



If you have an MQ Account, to obtain a Username and Password, E-mail us at: parts@multiquip.com.

To obtain an MQ Account, contact your District Sales Manager for more information.

Goto www.multiquip.com and click on **Order Parts** to log in and save!

Use the **internet** and qualify for a **5% Discount** on *Standard orders* for all orders which include complete part numbers.*

Note: Discounts Are Subject To Change

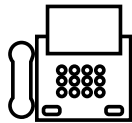

Order via Fax (Dealers Only):

All customers are welcome to order parts via Fax.

Domestic (US) Customers dial:
1-800-6-PARTS-7 (800-672-7877)

Fax your order in and qualify for a **2% Discount** on *Standard orders* for all orders which include complete part numbers.*

Note: Discounts Are Subject To Change



Order via Phone: Domestic (US) Dealers Call:
1-800-427-1244

Non-Dealer Customers:

Contact your local Multiquip Dealer for parts or call 800-427-1244 for help in locating a dealer near you.



International Customers should contact their local Multiquip Representatives for Parts Ordering information.

When ordering parts, please supply:

- | | |
|---|--|
| <input type="checkbox"/> Dealer Account Number | <input type="checkbox"/> Specify Preferred Method of Shipment: |
| <input type="checkbox"/> Dealer Name and Address | <input checked="" type="checkbox"/> UPS/Fed Ex <input checked="" type="checkbox"/> DHL |
| <input type="checkbox"/> Shipping Address (if different than billing address) | <input type="checkbox"/> Priority One <input checked="" type="checkbox"/> Truck |
| <input type="checkbox"/> Return Fax Number | <input type="checkbox"/> Ground |
| <input type="checkbox"/> Applicable Model Number | <input type="checkbox"/> Next Day |
| <input type="checkbox"/> Quantity, Part Number and Description of Each Part | <input type="checkbox"/> Second/Third Day |

NOTICE

All orders are treated as *Standard Orders* and will ship the same day if received prior to 3PM PST.

WE ACCEPT ALL MAJOR CREDIT CARDS!



SAFETY INFORMATION

Do not operate or service the equipment before reading the entire manual. Safety precautions should be followed at all times when operating this equipment. Failure to read and understand the safety messages and operating instructions could result in injury to yourself and others.



SAFETY MESSAGES

The four safety messages shown below will inform you about potential hazards that could injure you or others. The safety messages specifically address the level of exposure to the operator and are preceded by one of four words: **DANGER**, **WARNING**, **CAUTION** or **NOTICE**.

SAFETY SYMBOLS

! DANGER

Indicates a hazardous situation which, if not avoided, **WILL** result in **DEATH** or **SERIOUS INJURY**.

! WARNING

Indicates a hazardous situation which, if not avoided, **COULD** result in **DEATH** or **SERIOUS INJURY**.







! CAUTION

Indicates a hazardous situation which, if not avoided, **COULD** result in **MINOR** or **MODERATE INJURY**.

NOTICE

Addresses practices not related to personal injury.

Potential hazards associated with the operation of this equipment will be referenced with hazard symbols which may appear throughout this manual in conjunction with safety messages.

Symbol	Safety Hazard
	Lethal exhaust gas hazards
	Explosive fuel hazards
	Burn hazards
	Respiratory hazards
	Accidental starting hazards
	Eye and hearing hazards
	Rotating parts hazards

SAFETY INFORMATION

GENERAL SAFETY

CAUTION

- **NEVER** operate this equipment without proper protective clothing, shatterproof glasses, respiratory protection, hearing protection, steel-toed boots and other protective devices required by the job or city and state regulations.



- **NEVER** operate this equipment when not feeling well due to fatigue, illness or when under medication.



- **NEVER** operate this equipment under the influence of drugs or alcohol.



- **ALWAYS** check the equipment for loosened threads or bolts before starting.
- **DO NOT** use the equipment for any purpose other than its intended purposes or applications.
- **ALWAYS** clear the work area of any debris, tools, etc. that would constitute a hazard while the equipment is in operation.

NOTICE

- This equipment should only be operated by trained and qualified personnel 18 years of age and older.
- Whenever necessary, replace nameplate, operation and safety decals when they become difficult read.
- Manufacturer does not assume responsibility for any accident due to equipment modifications. Unauthorized equipment modification will void all warranties.
- **NEVER** use accessories or attachments that are not recommended by Multiquip for this equipment. Damage to the equipment and/or injury to user may result.
- **ALWAYS** know the location of the nearest **fire extinguisher**.
- **ALWAYS** know the location of the nearest **first aid kit**.
- **ALWAYS** know the location of the nearest phone or **keep a phone on the job site**. Also, know the phone numbers of the nearest **ambulance, doctor and fire department**. This information will be invaluable in the case of an emergency.

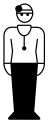

SAFETY INFORMATION

COMPACTOR SAFETY

DANGER

- **NEVER** operate the equipment in an explosive atmosphere or near combustible materials. An explosion or fire could result causing severe **bodily harm or even death.**



WARNING

- **NEVER** disconnect any **emergency or safety devices.** These devices are intended for operator safety. Disconnection of these devices can cause severe injury, bodily harm or even death. Disconnection of any of these devices will void all warranties.

CAUTION

- **NEVER** lubricate components or attempt service on a running machine.

NOTICE

- **ALWAYS** keep the machine in proper running condition.
- Fix damage to machine and replace any broken parts immediately.
- **ALWAYS** store equipment properly when it is not being used. Equipment should be stored in a clean, dry location out of the reach of children and unauthorized personnel.

ENGINE SAFETY

DANGER

- The engine fuel exhaust gases contain poisonous carbon monoxide. This gas is colorless and odorless, and can cause death if inhaled.
- The engine of this equipment requires an adequate free flow of cooling air. **NEVER** operate this equipment in any enclosed or narrow area where free flow of the air is restricted. If the air flow is restricted it will cause injury to people and property and serious damage to the equipment or engine.



WARNING

- **DO NOT** place hands or fingers inside engine compartment when engine is running.
- **NEVER** operate the engine with heat shields or guards removed.
- Keep fingers, hands hair and clothing away from all moving parts to prevent injury.



CAUTION

- **NEVER** touch the hot exhaust manifold, muffler or cylinder. Allow these parts to cool before servicing equipment.



NOTICE

- **NEVER** run engine without an air filter or with a dirty air filter. Severe engine damage may occur. Service air filter frequently to prevent engine malfunction.
- **NEVER** tamper with the factory settings of the engine or engine governor. Damage to the engine or equipment can result if operating in speed ranges above the maximum allowable.
- **NEVER** tip the engine to extreme angles during lifting as it may cause oil to gravitate into the cylinder head, making the engine start difficult.





SAFETY INFORMATION

FUEL SAFETY

DANGER

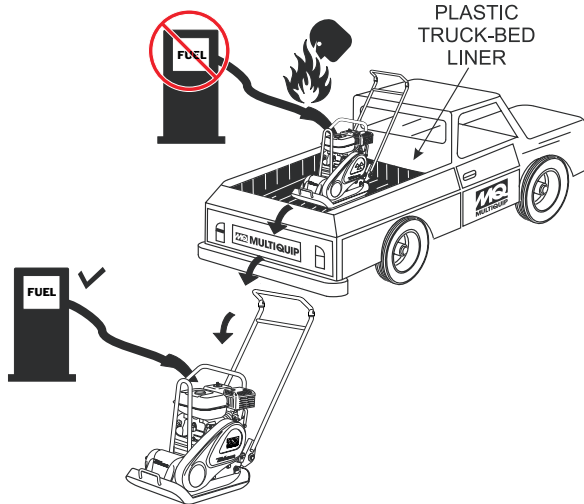
- **DO NOT** add fuel to equipment if it is placed inside truck bed with plastic liner. Possibility exists of explosion or fire due to static electricity.



- **DO NOT** start the engine near spilled fuel or combustible fluids. Diesel fuel is extremely flammable and its vapors can cause an explosion if ignited.
- **ALWAYS** refuel in a well-ventilated area, away from sparks and open flames.
- **ALWAYS** use extreme caution when working with **flammable** liquids.
- **DO NOT** fill the fuel tank while the engine is running or hot.
- **DO NOT** overfill tank, since spilled fuel could ignite if it comes into contact with hot engine parts or sparks from the ignition system.
- Store fuel in appropriate containers, in well-ventilated areas and away from sparks and flames.
- **NEVER** use fuel as a cleaning agent.
- **DO NOT** smoke around or near the equipment. Fire or explosion could result from fuel vapors or if fuel is spilled on a hot engine. 

BATTERY SAFETY (ELECTRIC START ONLY)

DANGER

- **DO NOT** drop the battery. There is a possibility that the battery will explode.
- **DO NOT** expose the battery to open flames, sparks, cigarettes, etc. The battery contains combustible gases and liquids. If these gases and liquids come into contact with a flame or spark, an explosion could occur. 

WARNING

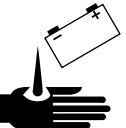
- **ALWAYS** wear safety glasses when handling the battery to avoid eye irritation. The battery contains acids that can cause injury to the eyes and skin. 
- Use well-insulated gloves when picking up the battery.
- **ALWAYS** keep the battery charged. If the battery is not charged, combustible gas will build up.
- **DO NOT** charge battery if frozen. Battery can explode. When frozen, warm the battery to at least 61°F (16°C).
- **ALWAYS** recharge the battery in a well-ventilated environment to avoid the risk of a dangerous concentration of combustible gases.
- If the battery liquid (dilute sulfuric acid) comes into contact with **clothing or skin**, rinse skin or clothing immediately with plenty of water. 
- If the battery liquid (dilute sulfuric acid) comes into contact with **eyes**, rinse eyes immediately with plenty of water and contact the nearest doctor or hospital to seek medical attention.

CAUTION

- **ALWAYS** disconnect the **NEGATIVE battery terminal** before performing service on the equipment.
- **ALWAYS** keep battery cables in good working condition. Repair or replace all worn cables.

SAFETY INFORMATION

TRANSPORTING SAFETY

CAUTION

- NEVER allow any person or animal to stand underneath the equipment while lifting.

NOTICE

- Before lifting, make sure that the equipment parts (hook and vibration insulator) are not damaged and screws are not loose or missing.
- Always make sure crane or lifting device has been properly secured to the lifting bail (hook) of the equipment.
- **ALWAYS** shutdown engine before transporting.
- **NEVER** lift the equipment while the engine is running.
- Tighten fuel tank cap securely and close fuel cock to prevent fuel from spilling.
- Use adequate lifting cable (wire or rope) of sufficient strength.
- Use one point suspension hook and lift straight upwards.
- **DO NOT** lift machine to unnecessary heights.
- **ALWAYS** tie down equipment during transport by securing the equipment with rope.

ENVIRONMENTAL SAFETY/DECOMMISSIONING

NOTICE

Decommissioning is a controlled process used to safely retire a piece of equipment that is no longer serviceable. If the equipment poses an unacceptable and unrepairable safety risk due to wear or damage or is no longer cost effective to maintain (beyond life-cycle reliability) and is to be decommissioned (demolition and dismantlement), be sure to follow rules below.

- **DO NOT** pour waste or oil directly onto the ground, down a drain or into any water source.
- Contact your country's Department of Public Works or recycling agency in your area and arrange for proper disposal of any electrical components, waste or oil associated with this equipment.



- When the life cycle of this equipment is over, remove battery and bring to appropriate facility for lead reclamation. Use safety precautions when handling batteries that contain sulfuric acid.
- When the life cycle of this equipment is over, it is recommended that the trowel frame and all other metal parts be sent to a recycling center.

Metal recycling involves the collection of metal from discarded products and its transformation into raw materials to use in manufacturing a new product.

Recyclers and manufacturers alike promote the process of recycling metal. Using a metal recycling center promotes energy cost savings.

EMISSIONS INFORMATION

NOTICE

The gasoline engine used in this equipment has been designed to reduce harmful levels of carbon monoxide (CO), hydrocarbons (HC) and nitrogen oxides (NOx) contained in gasoline exhaust emissions.

This engine has been certified to meet US EPA Evaporative emissions requirements in the installed configuration.

Attempting to modify or make adjustments to the engine emission system by unauthorized personnel without proper training could damage the equipment or create an unsafe condition.

Additionally, modifying the fuel system may adversely affect evaporative emissions, resulting in fines or other penalties.

Emission Control Label

The emission control label is an integral part of the emission system and is strictly controlled by regulation(s).

The label must remain with the engine for its entire life.

If a replacement emission label is needed, please contact your authorized engine distributor.

SPECIFICATIONS

Table 1. MVC88VTH/VTHW Plate Compactor Specifications	
Centrifugal Force	3,372 lbs. (1,530 kg)
Vibration Frequency	6,000 vpm (60 Hz)
Traveling Speed	82 ft/min (25 m/min)
Plate Size (L x W)	19.7 x 20.7 in (.500 x .525 mm)
Max. Area of Compaction (no extensions)	8,100 sq. ft./hr (752 sq. m/hr)
Operating Weight MVC88VTH	207 lbs. (95 kg.)
Operating Weight MVC88VTHW	229 lbs. (104 kg.)
Water Tank Capacity	13.7 qt (13.0 liters)
Anti-Vibration Handle	Yes
Lubricating Oil in Vibration Case	6.7 fl. oz. (200 cc)

Table 2. Engine Specifications	
Engine Make	HONDA
Engine Model	GX160UT2QMX2 GX160UT2QMXC
Engine Type	Air-cooled 4 stroke, Single Cylinder, OHV, Horizontal Shaft Gasoline Engine
Cylinder Bore X Stroke	2.7 in. x 1.8 in. (68 mm x 45 mm)
Displacement	163 cc (9.9 cu-in)
Maximum Output	4.8 HP (3.6 kW) @ 3600 RPM
Fuel Tank Capacity	Approx. .825 U.S. gallons (3.1 liters)
Fuel Type	Unleaded 86 Octane or Higher
Oil Capacity	.61 qts (0.58 liters)
Air Cleaner	Dual Element Cyclone
Starting Method	Recoil Start
Dry Net Weight Recoil/Electric	33 lbs (15 Kg.)
Dimensions (L x W x H)	12.2 x 14.3 x 13.6 in (312 x 362 x 346 mm)

NOISE AND VIBRATION EMISSIONS

Table 3. Noise and Vibration Emissions

Measured Sound Power Level in dB(A)	104
Guaranteed Sound Power Level in dB(A)	105
Guaranteed Sound Pressure Level at Operator Station in dB(A)	94
Hand-Arm Vibration in m/s ²	2.1

NOTES:

1. *Products are tested for sound pressure level in accordance with European Directives 2000/14/EC and 2005/88/EC, relating to Noise Emission in the Environment by equipment for use outdoors.*
2. *Products are tested for hand/arm vibration (HAV) level in accordance with European Directives 2002/44/EC and EN500-4 and ISO 5349-1:2001, ISO 5349-2:2001.*

DIMENSIONS

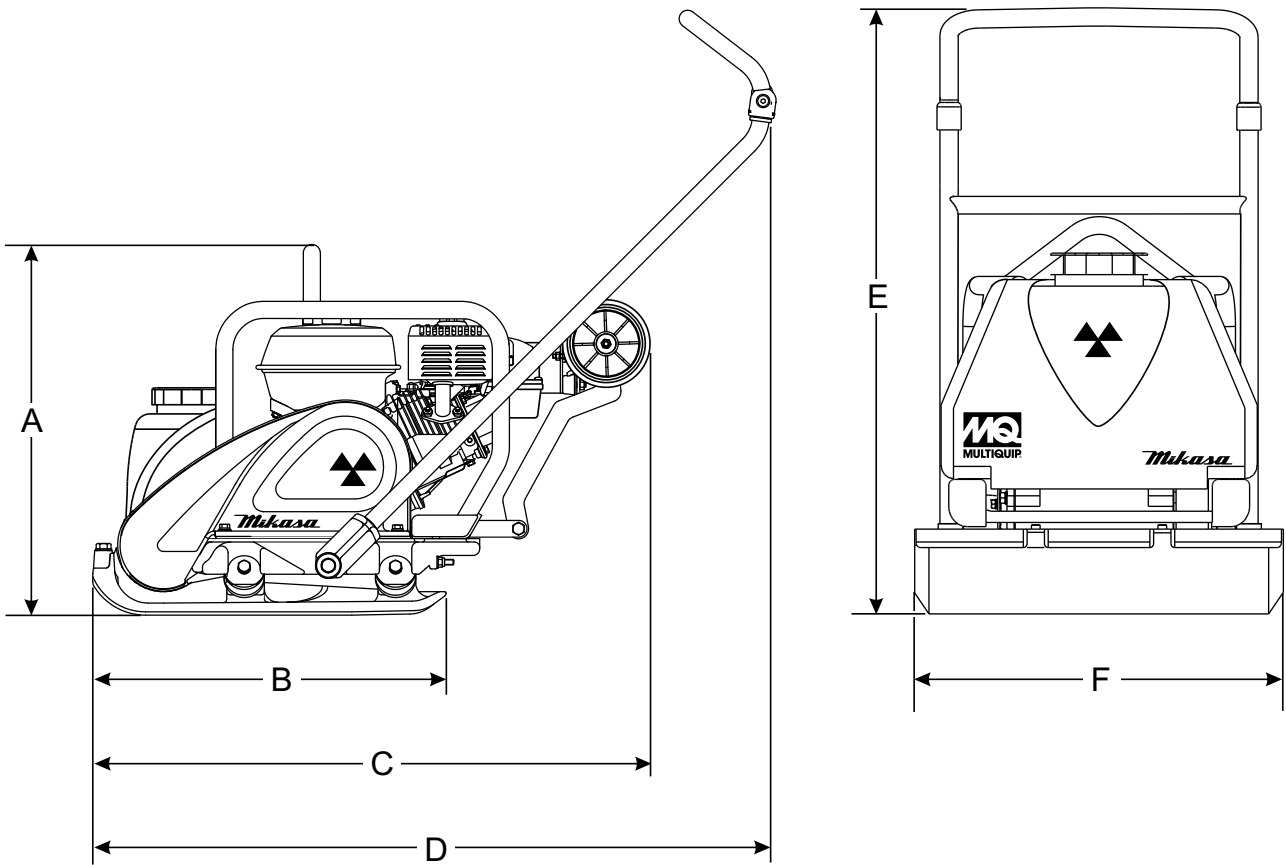

Figure 1. Dimensions

Table 4. Dimensions	
REF. DES	IN. (MM)
A	21.9 (557)
B	20.6 (525)
C	32.6 (830)
D	37.4(950)
E	41.3 (1050)
F	19.7 (500)

GENERAL INFORMATION

DEFINITION OF PLATE COMPACTOR

The Mikasa MVC88VTH/VTHW is a walk behind, plate compactor designed for the compaction of sand, mixed soils and asphalt. This plate compactor is a powerful compacting tool capable of applying a tremendous force in consecutive high frequency vibrations to a soil surface. Its applications include compacting for road, embankments and reservoirs as well as backfilling for gas pipelines, water pipelines and cable installation work.

VIBRATORY PLATES

The vibratory plates of the compactor produce low amplitude high frequency vibrations, designed to compact granular soils and asphalt.

The resulting vibrations cause forward motion. The engine and handle are vibration isolated from the vibrating plate.

FREQUENCY/SPEED

The compactor's vibrating plate produces a vibration frequency of 6,000 VPM (vibrations per minute). The travel speed of the compactor is approximately 82 ft/minute (25 meters/minute).

ENGINE

These plate compactors are equipped with either a Honda GX160UT2QMX2 or GX160UT2QMXC air cooled, 4-cycle gasoline engine. The engine drives an eccentric weight at a high speed to develop a compaction force.

In addition this engine is equipped with an **oil alert** system that will automatically stop the engine before the engine falls below safe engine oil operating limits. Always be sure to check the engine oil level prior to starting the engine.

CONTROLS

Before starting the plate compactor identify and understand the function of **all** the controls and components.

COMPACTOR COMPONENTS

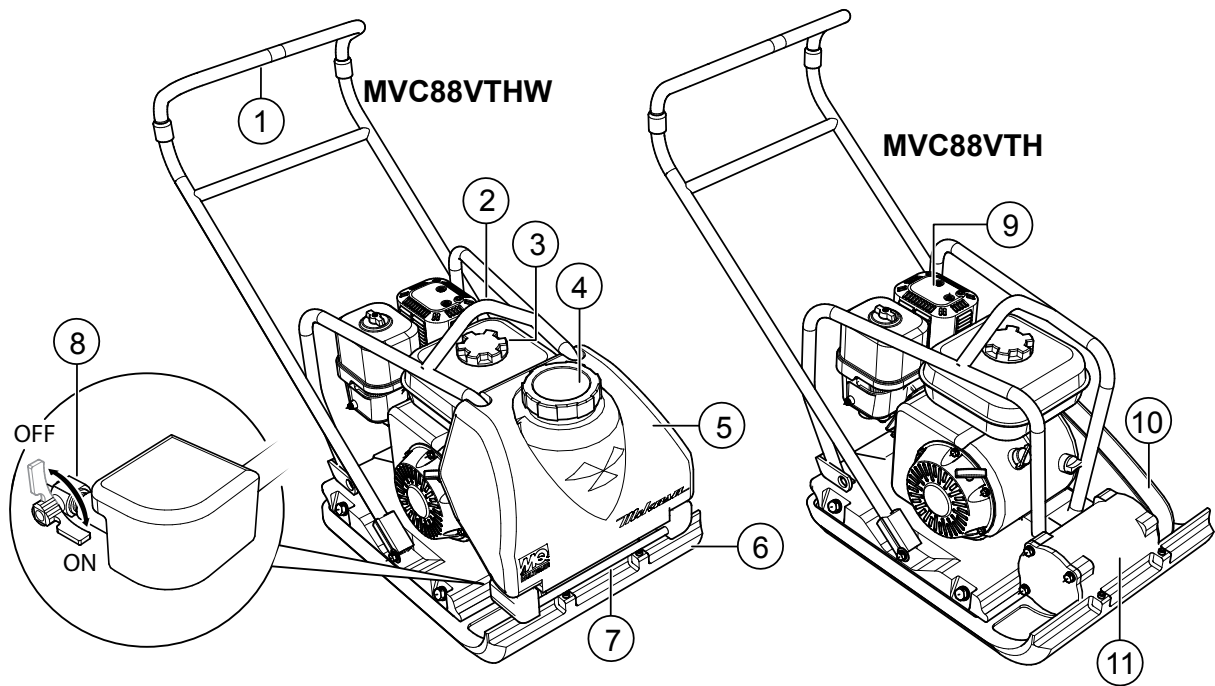

Figure 2. Plate Compactor Components

Figure 2 shows the location of the basic controls and components of the MVC88VTH/VTHW Plate Compactor. The function of each control is described below:

1. **Handle Bar** – When operating the compactor use this handle bar to maneuver the compactor.
2. **Lifting Bale** – When lifting of the compactor is required either by forklift, crane etc., tie rope or chain around this lifting point.
3. **Fuel Tank Cap** – Remove this cap to add fuel. Use only unleaded fuel with an octane rating of 86 or higher.
4. **Water Tank Cap (VTHW Only)** – Remove this cap to add water to the water tank.
5. **Water Tank (VTHW only)** – Holds 13.7 quarts of water (removable, no tools required).
6. **Vibrating Plate** – A flat, open plate made of durable cast iron construction used in the compacting of soil.
7. **Water Tube-Sprinkler (VTHW Only)** – Supplies water to the soil via a splash plate.
8. **Water Shut-Off Valve (VTHW Only)** – Turn this valve downward to let water flow from the water tank to the water tube.
9. **Engine** – These plate compactors use a Honda GX160, 4.8 HP, air-cooled 4 stroke gasoline engine. Refer to the Honda owner's manual for more detailed engine information and related topics.
10. **Belt Cover** – Remove this cover to gain access to the V-belts. **NEVER** run the compactor without the V-belt cover. If the V-belt cover is not installed, the possibility exists that your hand may get caught between the V-belt and clutch, causing serious injury and bodily harm.
11. **Eccentric Housing** – Encloses the eccentric, gears and counter weights.

COMPACTOR COMPONENTS

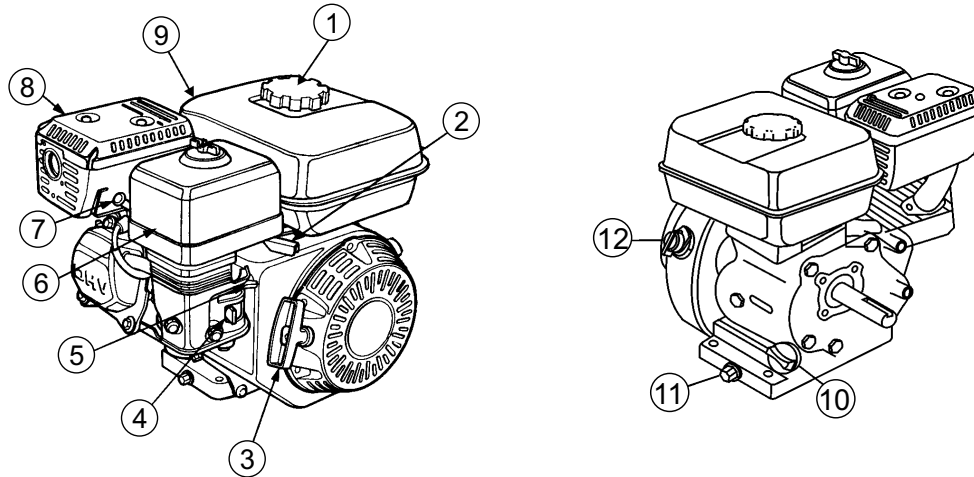

Figure 3. Engine Controls and Components

INITIAL SERVICING

The engine (Figure 3) must be checked for proper lubrication and filled with fuel prior to operation. Refer to the manufacturer's engine manual for instructions and details of operation and servicing.

1. **Fuel Filler Cap** – Remove this cap to add unleaded gasoline to the fuel tank. Make sure cap is tightened securely. **DO NOT** over fill.

DANGER



Add fuel to the tank only when the engine is stopped and has had an opportunity to cool down. In the event of a fuel spill, **DO NOT** attempt to start the engine until the fuel residue has been completely wiped up and the area surrounding the engine is dry.

2. **Throttle Lever** – Used to adjust engine RPM speed. For normal operation this lever should always be placed in the **RUN** position.
3. **Recoil Starter (Pull Rope)** – Manual-starting method. Pull the starter grip until resistance is felt, then pull briskly and smoothly.
4. **Fuel Valve Lever** – **OPEN** to let fuel flow, **CLOSE** to stop the flow of fuel.
5. **Choke Lever** – Used in the starting of a cold engine, or in cold weather conditions. The choke enriches the fuel mixture.

6. **Air Cleaner** – Prevents dirt and other debris from entering the fuel system. Remove wing-nut on top of air filter cover to gain access to filter element. In addition clean cyclone pre-cleaner housing (GX160UT2QMXC) as referenced in the maintenance section in this manual.

NOTICE

Operating the engine without an air filter, with a damaged air filter, or a filter in need of replacement will allow dirt to enter the engine, causing rapid engine wear.

7. **Spark Plug** – Provides spark to the ignition system. Set spark plug gap according to engine manufacturer's instructions. Clean spark plug once a week.
8. **Muffler** – Used to reduce noise and emissions. **NEVER** touch when **hot!**
9. **Fuel Tank** – Fill with unleaded gasoline. Reference Table 2 for fuel tank capacity. For additional information refer to Honda engine owner's manual.
10. **Dipstick/Oil Filler Cap** – Remove this cap to determine if the engine oil is low. Add oil through this filler port as recommended in (Table 5).
11. **Oil Drain Plug** – Remove this plug to remove oil from the engine's crankcase.
12. **Engine ON/OFF Switch** – **ON** position permits engine starting, **OFF** position stops engine operation.

Before Starting

1. Read all safety instructions at the beginning of manual.
2. Clean the compactor, removing dirt and dust, particularly the engine cooling air inlet, carburetor and air cleaner.
3. Check the air filter for dirt and dust. If air filter is dirty, replace air filter with a new one as required.
4. Check carburetor for external dirt and dust. Clean with dry compressed air.
5. Check fastening nuts and bolts for tightness.

Engine Oil Check

1. To check the engine oil level, place the compactor on secure level ground with the engine stopped.
2. Remove the dipstick from the engine oil filler hole (Figure 4) and wipe clean.

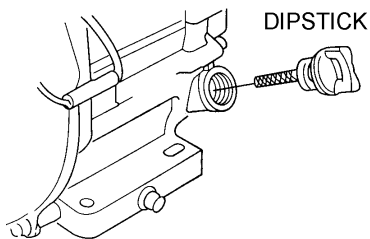

Figure 4. Engine Oil Dipstick Removal

3. Insert and remove the dipstick without screwing it into the filler neck. Check the oil level shown on the dipstick.
4. If the oil level is low (Figure 5), fill to the edge of the oil filler hole with the recommended oil type as listed in Table 5. Reference Table 2 for maximum engine oil capacity.

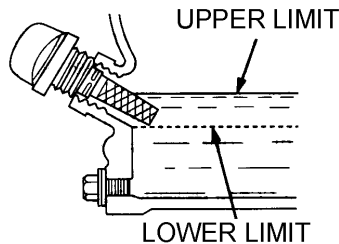

Figure 5. Engine Oil Dipstick (Oil Level)

Table 5. Oil Type

Season	Temperature	Oil Type
Summer	25°C or Higher	SAE 10W-30
Spring/Fall	25°C~10°C	SAE 10W-30/20
Winter	0°C or Lower	SAE 10W-10

DANGER



EXPLOSIVE FUEL!

Motor fuels are highly flammable and can be dangerous if mishandled. **DO NOT** smoke while refueling. **DO NOT** attempt to refuel the compactor if the engine is hot! or running.

Fuel Check

1. Visually inspect (Figure 6) to see if fuel level is low. If fuel is low, replenish with unleaded fuel.

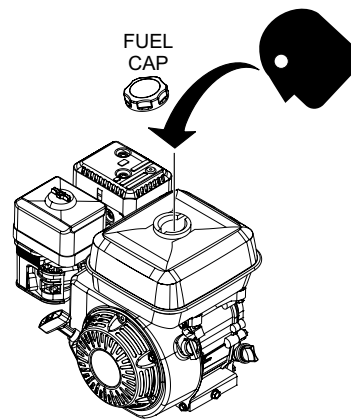

Figure 6. Fuel Check

2. When refueling, be sure to use a strainer for filtration. **DO NOT** top-off fuel. Wipe up any spilled fuel immediately.

Water Tank (Option)

If your unit is equipped with a water tank (Figure 7) and your applications requires water, fill water tank.

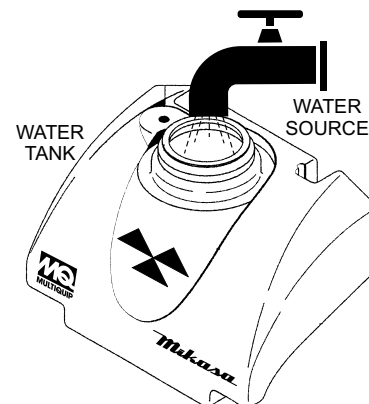

Figure 7. Water Tank Filling

V-BELT

V-Belt Cover Removal

To inspect the V-belt, remove the three bolts that secure the belt cover to the frame as shown in Figure 8.

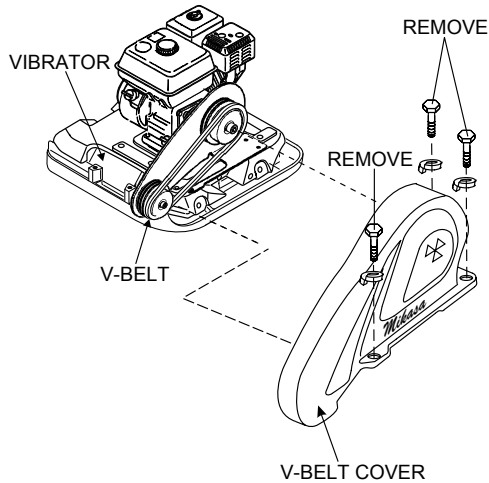

Figure 8. V-Belt Cover Removal

V-Belt Inspection

Visually examine the V-belt (Figure 9) and determine if it is full of tiny cracks, frayed, has pieces of rubber missing, is peeling or otherwise damaged.

Also, examine the belt and determine if it is **oil soaked** or **"glazed"** (hard shiny appearance on the sides of the belt). Either of these two conditions can cause the belt to run hot, which can weaken it and increase the danger of it breaking.

If the V-belt exhibits any of the referenced wear conditions replace the V-belt immediately

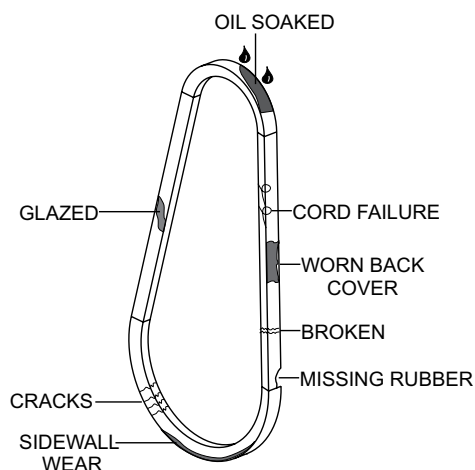

Figure 9. Drive Belt Inspection

V-Belt Tension

The V-belt tension is proper if the V-belt bends 10 to 15 mm (Figure 10) when depressed with finger at midway between the clutch and vibrator pulleys.

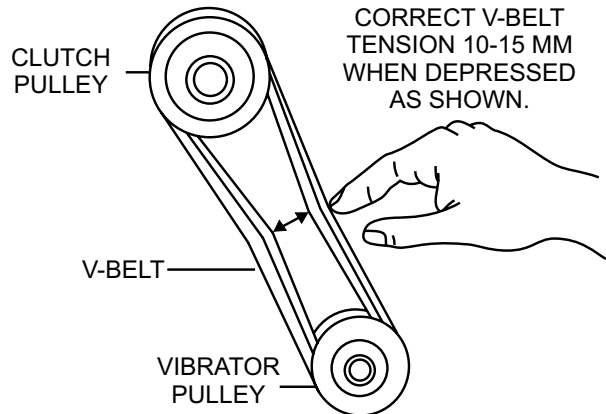

Figure 10. V-Belt Tension

Vibrator Oil Check

1. Place the plate compactor horizontally on a flat surface. Make sure the compactor is level when checking the oil in the vibrator assembly.
2. Check vibrator oil level by removing the oil plug (vibrator oil gauge) as shown in Figure 11. The oil level should be up to the oil plug.
3. The vibrator holds approximately 6.7 oz. (200 cc). **IMPORTANT**, if oil is required, replace using only SAE 10W-30 motor oil.

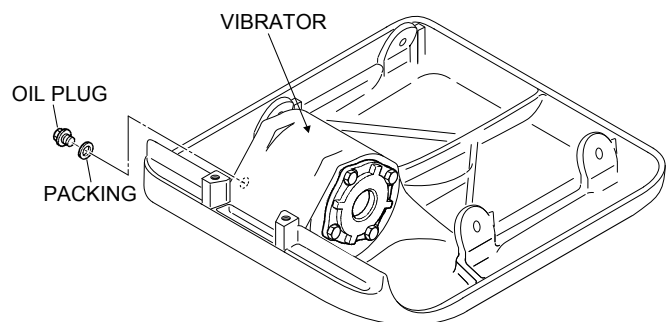

Figure 11. Vibrator Oil Check

CAUTION



DO NOT attempt to operate the compactor until the Safety, General Information and Inspection sections of this manual have been *read and thoroughly understood*.

This section is intended to assist the operator with the initial start-up of the compactor. It is extremely important that this section be read carefully before attempting to use the compactor in the field.

STARTING THE ENGINE

1. Place the engine fuel valve lever (Figure 12) to the "ON" position.

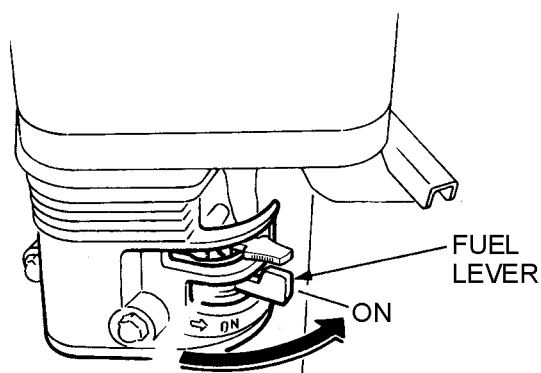

Figure 12. Engine Fuel Valve Lever (ON Position)

2. Move the throttle lever (Figure 13) away from the *idle* position, about 1/3 of the way toward the *run* position.

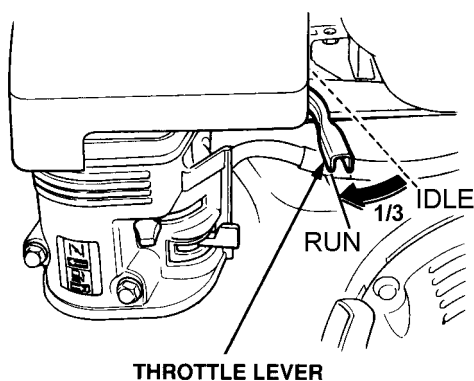

Figure 13. Throttle Lever (1/3 Start Position)

3. Place the choke lever (Figure 14) in the "CLOSED" position if starting a cold engine.

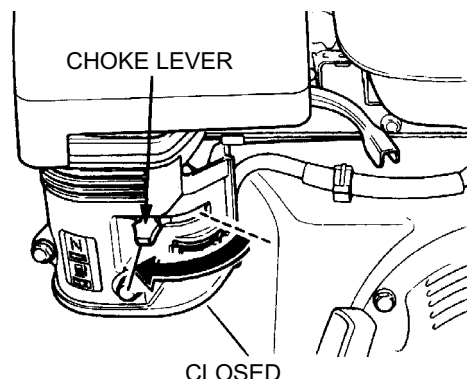

Figure 14. Choke Lever (Closed)

NOTICE

The **CLOSED** position of the choke lever enriches the fuel mixture for starting a **COLD** engine. The **OPEN** position provides the correct fuel mixture for normal operation after starting, and for restarting a warm engine.

4. Place the engine ON/OFF switch (Figure 15) in the "ON" position.

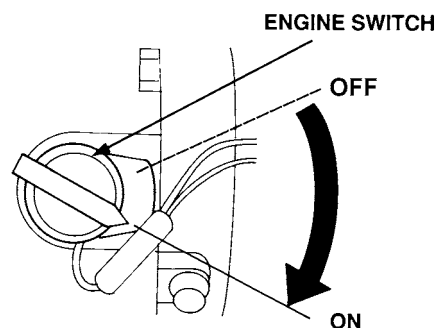

Figure 15. Engine ON/OFF Switch (ON Position)

5. Grasp the starter grip (Figure 16) and slowly pull it out. The resistance becomes the hardest at a certain position, corresponding the compression point. Rewind the rope a little from that point and pull out sharply.

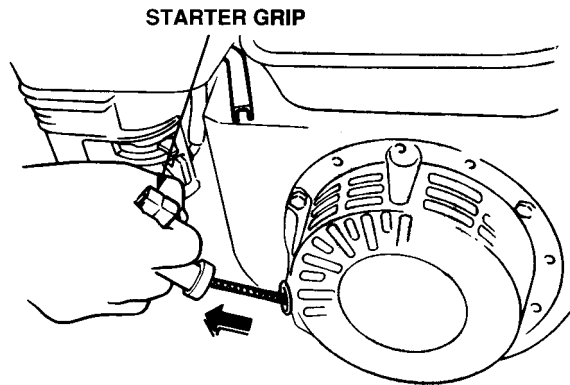

Figure 16. Starter Grip

NOTICE

DO NOT pull the starter rope all the way to the end
DO NOT release the starter rope after pulling. Allow it to rewind as soon as possible.

6. When engine starts, release the starter grip and allow the rope to recoil.
7. If the choke lever was moved to the "CLOSED" position to start the engine gradually move it to the "OPEN" position (Figure 17) as the engine warms up. If the engine has not started repeat steps 1 through 6.

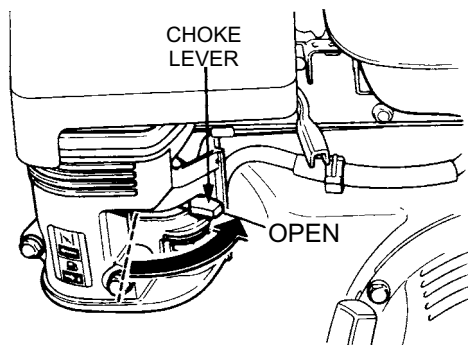

Figure 17. Choke Lever (Open)

8. Before the compactor is placed in to operation, run the engine for several minutes. Check for fuel leaks, and noises that would associate with a lose component.

9. If the sprinkling of water is required, place water valve in the **ON** position.

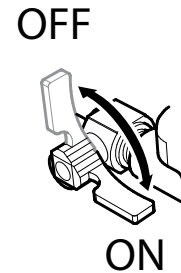

Figure 18. Water Valve (ON)

10. To begin compacting, place the throttle lever (Figure 19) in the "RUN" position.

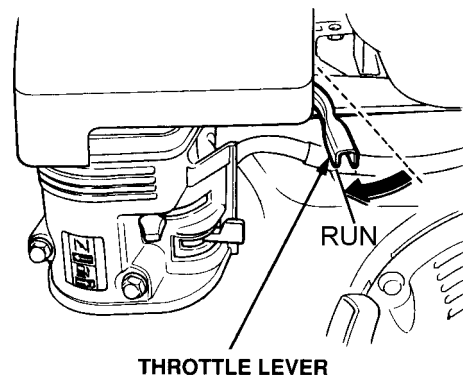

Figure 19. Throttle Lever (Run)

OPERATION

CAUTION



ALWAYS follow all safety rules referenced in the safety section of this manual before operating compactor. Keep work area clear of debris and other objects that could cause damage to the compactor or bodily injury.

1. Once the engine has started, move the engine throttle lever quickly to the **run** position.
2. With the throttle lever in the run position, the engine speed should be around 2,300 RPM, therefore engaging the centrifugal clutch.

NOTICE

ALWAYS move the throttle lever quickly without hesitation, because increasing the engine speed slowly causes the clutch to slip.

3. Firmly gasp the compactor's handle bar with both hands, the compactor will begin moving forward.
4. Slowly walk behind the compactor and be on the lookout for any large objects or foreign matter that might cause damage to the compactor or bodily injury.

NOTICE

NEVER stop the engine suddenly while working at high speeds.

5. Compactor traveling speed may drop on soils which contain clay, however there may be cases where traveling speed drops because the compaction plate does not leave the ground surface easily due to the composition of the soil. To rectify this problem do the following:
 - Check the bottom plate to see if clay or equivalent material has been lodge in the plate mechanism. If so, wash with water and remove.
 - Remember the compactor does not work as efficiently on clay or soils that have a high moisture content level.
 - If the soil has a high moisture level, dry soil to appropriate moisture content level or carry out compaction twice.

STOPPING THE ENGINE

Normal Shutdown

1. Move the throttle lever to the **idle** position (Figure 20) and run the engine for three minutes at low speed.

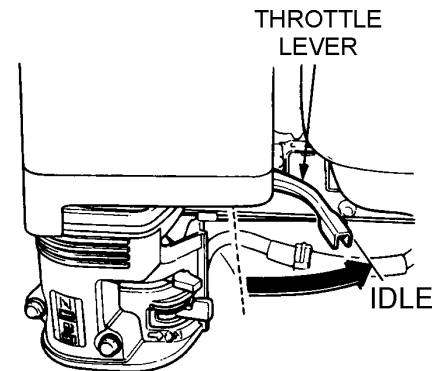

Figure 20. Throttle Lever (Idle)

2. Place the engine ON/OFF switch (Figure 21) in the **"OFF"** position.

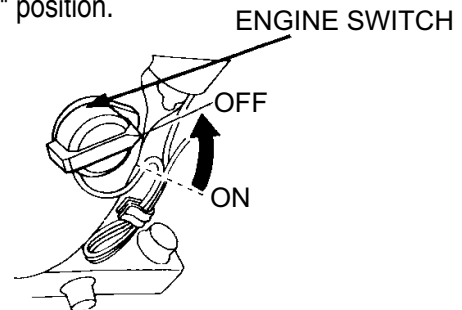

Figure 21. Engine ON/OFF Switch (OFF Position)

3. Place the fuel shut-off lever (Figure 22) in the **"OFF"** position.

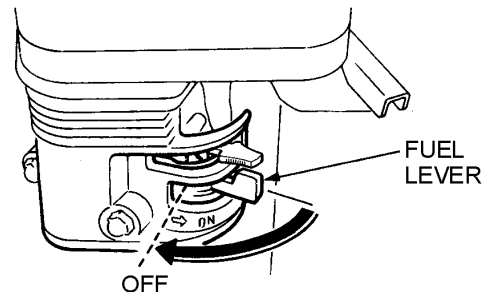

Figure 22. Fuel Valve Lever (OFF)

4. If applicable place water valve (Figure 18) in the **OFF** position.

Emergency Shutdown

1. Move the throttle lever quickly to the **IDLE** position, and place the engine ON/OFF switch in the **OFF** position.

OPERATION/MAINTENANCE

MAINTENANCE

General maintenance practices are crucial to the performance and longevity of your compactor. This equipment requires routine cleaning, inspection and lubrication. Reference Table 6 and Table 7 for scheduled engine and compactor maintenance.

The following procedures, devoted to maintenance, can prevent serious compactor damage or malfunctioning.

NOTICE

Reference **HONDA** engine manual supplied with your compactor for more detailed engine maintenance and troubleshooting.

CAUTION



ALWAYS allow the engine to cool before servicing. **NEVER** attempt any maintenance work on a hot engine.

CAUTION

ALWAYS disconnect the spark plug wire from the spark plug and secure away from the engine before performing maintenance or adjustments on the machine.

WARNING



Some maintenance operations may require the engine to be run. Ensure that the maintenance area is well ventilated. Gasoline engine exhaust contains poisonous carbon monoxide gas that can cause unconsciousness and may result in **DEATH**

General Cleanliness

Clean the compactor daily. Remove all dust and debris buildup (mud, clay etc.). If the compactor is steam-cleaned, ensure that lubrication is accomplished **AFTER** steam cleaning.

NOTICE

Inspection and other services should always be carried out on hard and level ground with the engine shutdown.

NOTICE

The inspection intervals listed in the maintenance tables are for operation under normal conditions. Adjust your inspection intervals based on the number hours plate compactor is in use, and particular working conditions.

Inspection and Maintenance Service Tables

To make sure your plate compactor is always in good working condition before using, carry out the maintenance inspection in accordance with Table 6 and Table 7.

Engine Maintenance

Perform engine maintenance as listed in Table 6.

Table 6. Engine Maintenance Schedule							
Description (3)	Operation	Before	First Month or 10 hrs	Every 3 Months or 25 hrs	Every 6 Months or 50 hrs	Every Year or 100 hrs	Every 2 Years or 200 hrs
Engine Oil	CHECK	X					
	CHANGE		X				
Air Cleaner	CHECK	X					
	CHANGE			X (1)			
All Nuts and Bolts	Re-tighten If Necessary	X					
Spark Plug	CHECK-CLEAN				X		
	REPLACE						X
Cooling Fins	CHECK				X		
Spark Arrester	CLEAN					X	
Fuel Tank	CLEAN					X	
Fuel Filter	CHECK					X	
Idle Speed	CHECK-ADJUST					X (2)	
Valve Clearance	CHECK-ADJUST						X (2)
Fuel lines	CHECK	Every 2 years (replace if necessary) (2)					

1. Service more frequently when used in **DUSTY** areas.
2. These items should be serviced by your service dealer, unless you have the proper tools and are mechanically proficient. Refer to the **HONDA** Shop Manual for service procedures.
3. For commercial use, log hours of operation to determine proper maintenance intervals.

Machine Inspection

Perform machine inspection as listed in Table 7.

Table 7. Machine Inspection		
Interval	Check	Solution
Daily Before Starting	Machine	Clean if necessary.
	Fuel Tank For Leaks	Repair fuel leaks.
	Fuel System for Leaks	Repair fuel leaks.
	Engine Oil	Add oil if necessary.
	Vibrator Oil	Add oil if necessary.
	Air Cleaner Element	Clean/Replace
	Cyclone Pre-Cleaner	Clean
	Guard Frame	Inspect/deformations
Shock Absorber	Replace if damaged.	
Every 20 Hours	Engine Oil	Replace only after first 20 hrs.
Every 100	Engine Oil	Change
	Air Cleaner Element	Clean/Replace
	Vibrator Oil	Check oil level. Check for leaks.
Every 200 hours	V-Belt	Inspect, replace if damaged or worn.
	Clutch	Inspect, replace if not working properly.
	Engine Bolts	Replace bolts if deformed or elongated.
Every 300 hours	Vibrator Oil	Change
	Fuel Filter	Change
Every 2 years	Fuel Lines	Replace

Tightening Torque

Reference Table 8 below (Tightening Torque), for retight-

Table 8. Tightening Torque (in. kg/cm Diameter)								
Material	6mm	8mm	10mm	12mm	14mm	16mm	18mm	20mm
4T	70	150	300	500	750	1,100	1,400	2,000
6-8T	100	250	500	800	1,300	2,000	2,700	3,800
11T	150	400	800	1,200	2,000	2,900	4,200	5,600
*	100 (6mm) 300 ~ 350 (8mm) 650 ~ 700 (10mm)							
**	In case counter-part is of aluminum							
Bolt threads used with this machine are all right handed								
Material and quality of material is marked on each bolt, and screw.								

Engine Air Cleaner

! DANGER



DO NOT use gasoline or low flash point solvents for cleaning the air cleaner. The possibility exists of fire or explosion which can cause damage to the equipment and severe bodily harm or even **DEATH!**

! CAUTION



Wear protective equipment such as approved safety glasses or face shields and dust masks or respirators when cleaning air filters with compressed air.

Dual Element Type

The Honda GX160UT2QMX2 engine is equipped with a replaceable, high-density paper air cleaner element. See (Figure 23) for air cleaner components.

1. Remove the air cleaner cover and foam filter element.
2. Tap the paper filter element several times on a hard surface to remove dirt, or blow compressed air not exceeding 30 psi (207 kPa, 2.1 kgf/cm²) through the filter element from the inside out. **NEVER** brush off dirt. Brushing will force dirt into the fibers. Replace the paper filter element if it is excessively dirty.

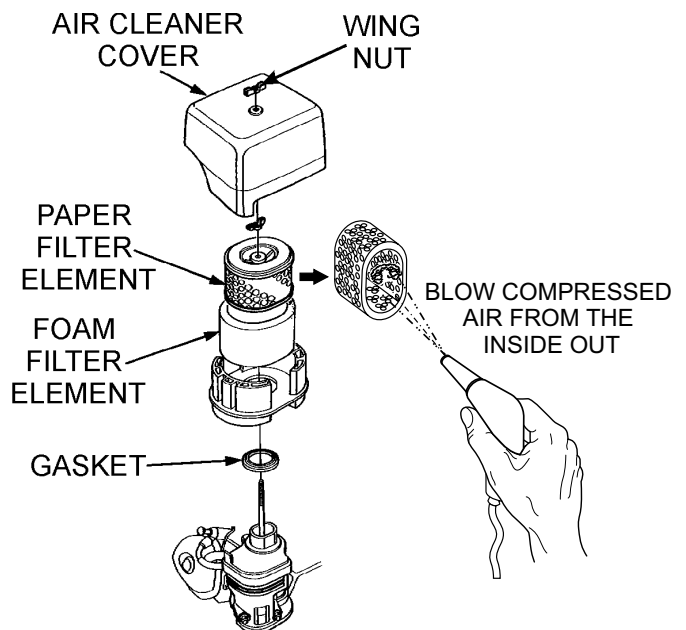

Figure 23. Engine Air Cleaner (Dual)

- Clean foam element in warm, soapy water or nonflammable solvent. Rinse and dry thoroughly. Dip the element in clean engine oil and completely squeeze out the excess oil from the element before installing.

NOTICE

Operating the engine with loose or damaged air cleaner components could allow unfiltered air into the engine causing premature wear and failure.

Oil Bath Type

The Honda GX160UT2QMXC engine is equipped with a replaceable, high-density paper air cleaner element. See (Figure 24) for air cleaner components.

- Follow steps 1 through 3 as outlined in the "Dual Element" section.
- Next, remove the pan head screws (3) that secure the cyclone housing to the pre-cleaner cap.
- Remove the cyclone housing and wash the components with water.
- Thoroughly dry housing and associated components and reassemble.

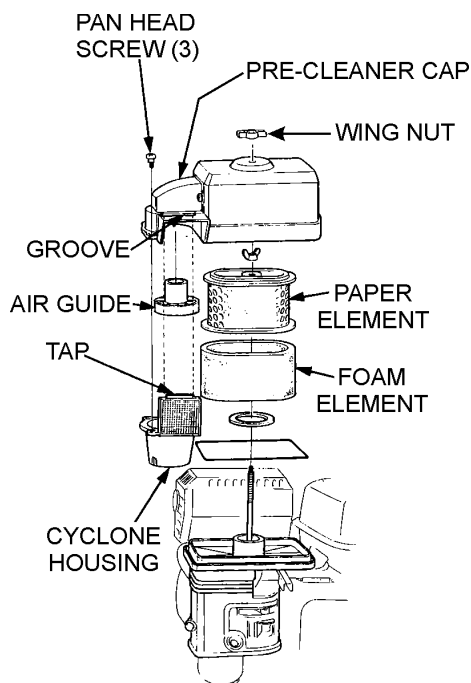

Figure 24. Engine Air Cleaner (Oil Bath)

NOTICE

When reinstalling cyclone housing, be sure that the air intake tab fits properly into the groove in the pre-cleaner cap. Also make sure air guide is properly aligned before inserting into pre-cleaner cap.

Engine Oil

- Drain the engine oil when the oil is warm as shown in (Figure 25).

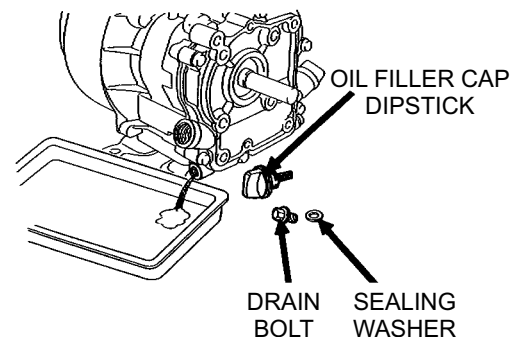

Figure 25. Draining Engine Oil

- Remove the oil drain bolt and sealing washer and allow the oil to drain into a suitable container.
- Replace engine oil with recommended type oil as listed in Table 5. For engine oil capacity, see Table 2 (Engine Specifications). **DO NOT** overfill.
- Reinstall drain bolt with sealing washer and tighten securely.

SPARK PLUG

NOTICE

NEVER use a spark plug of incorrect heat range.

- Remove and clean spark plug (Figure 26) with a wire brush if it is to be reused. Discard spark plug if the insulator is cracked or chipped.
- Using a feeler gauge adjust spark plug gap to 0.028 ~0.031 inch (0.7~0.8 mm).

3. Thread spark plug into cylinder hole by hand to prevent cross-threading, then tighten securely.

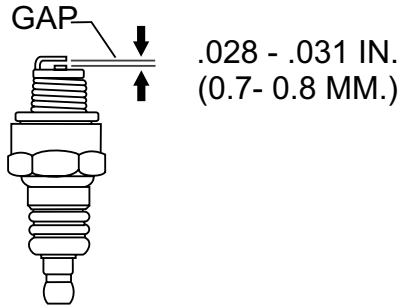

Figure 26. Spark Plug Gap

V-BELT

Visually examine the V-belt (Figure 27) and determine if it is full of tiny cracks, frayed, has pieces of rubber missing, is peeling or otherwise damaged.

Also, examine the belt and determine if it is **oil soaked** or **"glazed"** (hard shiny appearance on the sides of the belt). Either of these two conditions can cause the belt to run hot, which can weaken it and increase the danger of it breaking.

If the V-belt exhibits any of the above wear conditions replace the V-belt immediately.

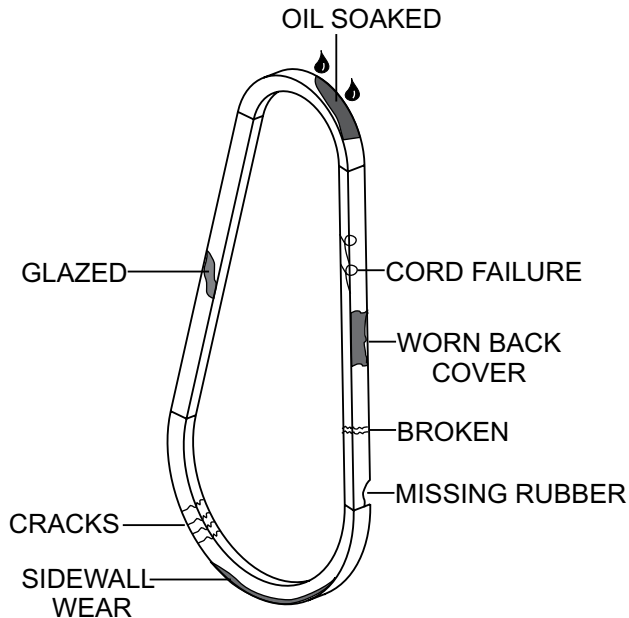

Figure 27. V-Belt Inspection

SPARK ARRESTER CLEANING

Clean the spark arrester every 6 months or 100 hours.

1. Remove the 4 mm screw (3) from the exhaust deflector, then remove the deflector. See (Figure 28).
2. Remove the 5 mm screw (4) from the muffler protector, then remove the muffler protector.
3. Remove the 4 mm screw from the spark arrester, then remove the spark arrester

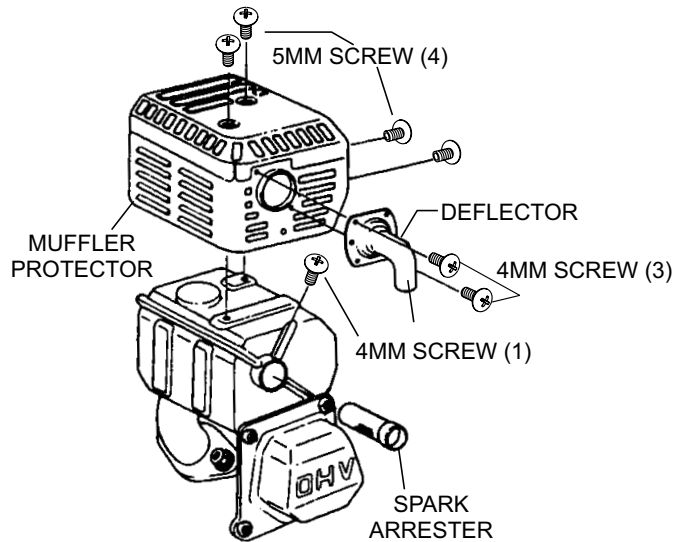

Figure 28. Spark Arrester Removal

4. Carefully remove carbon deposits from the spark arrester screen (Figure 29) with a wire brush.

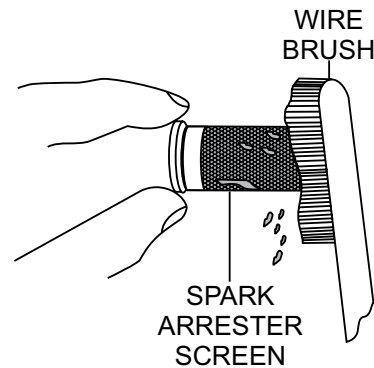

Figure 29. Cleaning The Spark Arrester

5. If the spark arrester is damaged and has breaks or holes, replace with a new one.
6. Reinstall the spark arrester and muffler protector in reverse order of disassembly.

EXPLANATION OF CODE IN REMARKS COLUMN

The following section explains the different symbols and remarks used in the Parts section of this manual. Use the help numbers found on the back page of the manual if there are any questions.

NOTICE

The contents and part numbers listed in the parts section are subject to change **without notice**. Multiquip does not guarantee the availability of the parts listed.

SAMPLE PARTS LIST

NO.	PART NO.	PART NAME	QTY.	REMARKS
1	12345	BOLT	1	INCLUDES ITEMS W/%
2%		WASHER, 1/4 IN.		NOT SOLD SEPARATELY
2%	12347	WASHER, 3/8 IN. ...	1	MQ-45T ONLY
3	12348	HOSE	A/R	MAKE LOCALLY
4	12349	BEARING	1	S/N 2345B AND ABOVE

NO. Column

Unique Symbols — All items with same unique symbol (@, #, +, %, or >) in the number column belong to the same assembly or kit, which is indicated by a note in the “Remarks” column.

Duplicate Item Numbers — Duplicate numbers indicate multiple part numbers, which are in effect for the same general item, such as different size saw blade guards in use or a part that has been updated on newer versions of the same machine.

NOTICE

When ordering a part that has more than one item number listed, check the remarks column for help in determining the proper part to order.

PART NO. Column

Numbers Used — Part numbers can be indicated by a number, a blank entry, or TBD.

TBD (To Be Determined) is generally used to show a part that has not been assigned a formal part number at the time of publication.

A blank entry generally indicates that the item is not sold separately or is not sold by Multiquip. Other entries will be clarified in the “Remarks” Column.

QTY. Column

Numbers Used — Item quantity can be indicated by a number, a blank entry, or A/R.

A/R (As Required) is generally used for hoses or other parts that are sold in bulk and cut to length.

A blank entry generally indicates that the item is not sold separately. Other entries will be clarified in the “Remarks” Column.

REMARKS Column

Some of the most common notes found in the “Remarks” Column are listed below. Other additional notes needed to describe the item can also be shown.

Assembly/Kit — All items on the parts list with the same unique symbol will be included when this item is purchased.

Indicated by:

“INCLUDES ITEMS W/(unique symbol)”

Serial Number Break — Used to list an effective serial number range where a particular part is used.

Indicated by:

“S/N XXXXX AND BELOW”

“S/N XXXX AND ABOVE”

“S/N XXXX TO S/N XXX”

Specific Model Number Use — Indicates that the part is used only with the specific model number or model number variant listed. It can also be used to show a part is NOT used on a specific model or model number variant.

Indicated by:

“XXXXX ONLY”

“NOT USED ON XXXX”

“Make/Obtain Locally” — Indicates that the part can be purchased at any hardware shop or made out of available items. Examples include battery cables, shims, and certain washers and nuts.

“Not Sold Separately” — Indicates that an item cannot be purchased as a separate item and is either part of an assembly/kit that can be purchased, or is not available for sale through Multiquip.

SUGGESTED SPARE PARTS

MVC88VTH/MVC88VTWH PLATE COMPACTOR WITH HONDA GX160UT2QMX2/ GX160UT2QMXC GASOLINE ENGINES

1 to 5 units

Qty.	P/N	Description
3070100332.....	V-BELT
50650140480.....	SPARK PLUG
128462ZH8003.....	ROPE, RECOIL STARTER
517210ZE1517.....	ELEMENT, AIR CLEANER
5◇17210ZE1822.....	ELEMENT, AIR CLEANER
117620Z4H020.....	CAP, FUEL TANK
1◇17620Z4H900.....	CAP, FUEL TANK
117672Z4H000.....	FUEL FILTER, FUEL TANK
4939010230.....	SHOCK ABSORBER

NOTICE

GX160UT2QMX2

◇ GX160UT2QMXC

NOTICE

Part numbers on this Suggested Spare Parts list may supersede/replace the part numbers shown in the following parts lists.

BODY ASSY.

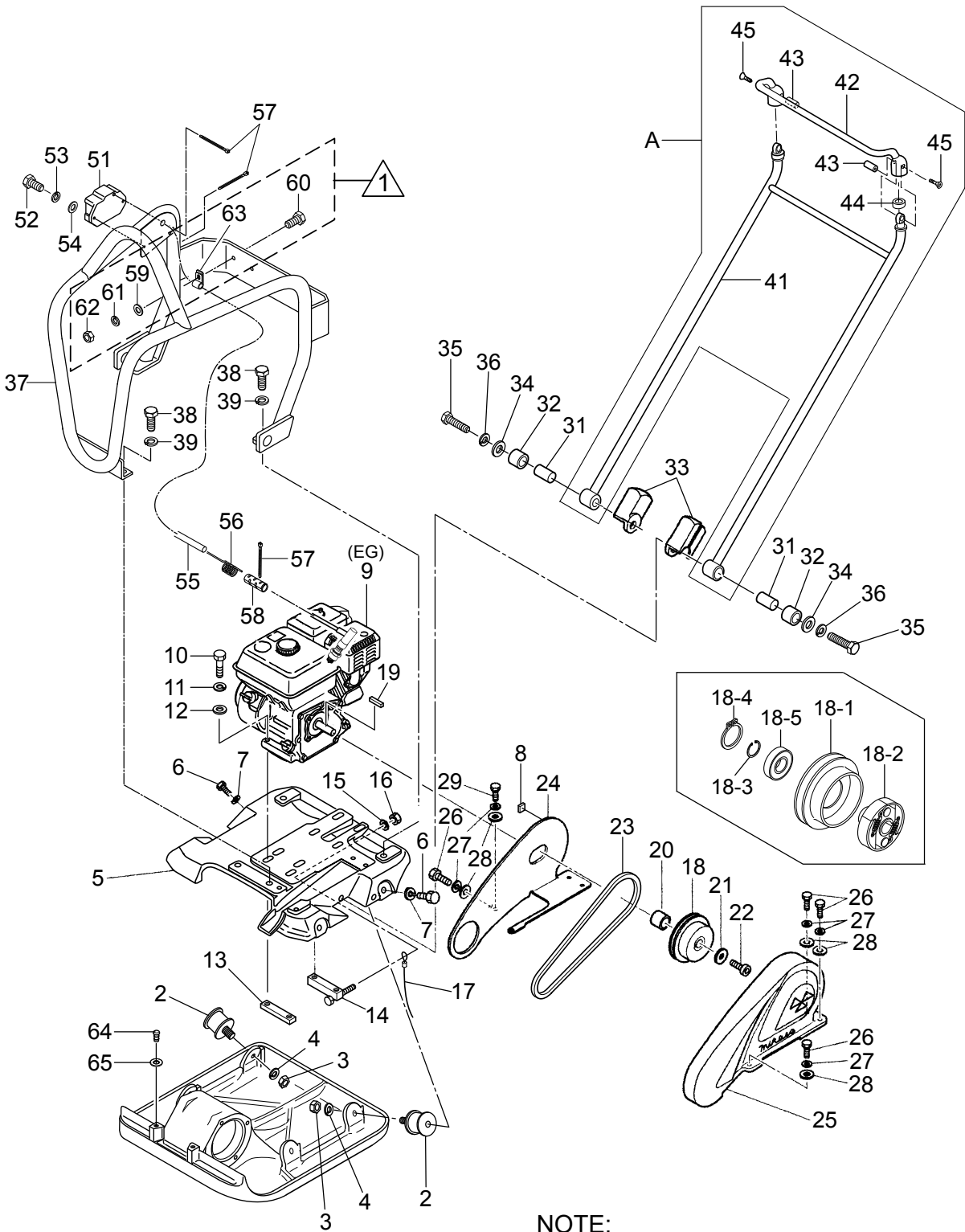

NOTE:
 1 ITEMS 59 THROUGH 62
 NOT REQUIRED WHEN CYCLONE
 AIR CLEANER INSTALLED
 (S/N T2A9198 AND ABOVE)

BODY ASSY.

<u>NO.</u>	<u>PART NO.</u>	<u>PART NAME</u>	<u>QTY.</u>	<u>REMARKS</u>
A	416910120	HANDLE ASSY.	1.....	INCLUDES ITEMS W/%
2	939010230	SHOCK ABSORBER	4	
3	020310080	NUT M10	4	
4	030210250	WASHER, LOCK M10	4	
5	416120390	BASE	1	
6	001221025	BOLT 10X25	4	
7	030210250	WASHER, LOCK M10	4	
8	416454360	RUBBER PLATE 25X25X8	1	
9	912216015	ENGINE ASSY.,GX160UT2QMX2.....	1.....	S/N T2A9197 AND BELOW
9	912216021	ENGINE ASSY.,GX160UT2QMXC	1.....	S/N T2A9198 AND ABOVE
10	001220850	BOLT 8X50	4	
11	030208200	WASHER, LOCK M8	4	
12	031108160	WASHER, FLAT M8	4	
13	416466520	ENGINE NUT	1	
14	416466540	ENGINE NUT	1	
15	031108160	WASHER, FLAT M8	1	
16	022710809	NYLON NUT M8	1	
17	959404350	EARTH WIRE, 1"	1	
18	416910100	CLUTCH ASSY	1	
18-1	416464490	CLUTCH DRUM, 1"	1	
18-2	416351320	CLUTCH SHOE AND BOSS ASSY.	1	
18-3	080200300	STOP RING, S30	1	
18-4	080600550	STOP RING, AR55	1	
18-5	042006006	BEARING 6006	1	
19	90745ZE1600	KEY 4.78X4.78X38	1	
20	416452809	COLLAR	1	
21	952400130	WASHER	1	
22	009110004	SOCKET HEAD BOLT 5/16"	1	
23	070100332	VBELT RPF3330	1	
24	416120950	BELT COVER, INNER	1	
25	416010040	BELT COVER, OUTER	1	
26	001220825	BOLT 8X25	4	
27	030208200	WASHER, LOCK M8	5	
28	031108160	WASHER, FLAT M8	5	
29	001220820	BOLT 8X20	1	
31	952408710	COLLAR 13X20X44	2	
32	404433430	RUBBER 20X32X28	2	
33	416452360	HANDLE STOPPER	2	
34	952405600	WASHER 12.5X35X4.5	2	
35	001221253	BOLT 12X65	2	
36	030212300	WASHER, LOCK M12	2	
37	416121050	GUARD HOOK	1.....	S/N T2A9197 AND BELOW
37	416121740	GUARD HOOK	1.....	S/N T2A9198 AND ABOVE
38	0105091025	BOLT 10X25	4	
39	030210250	WASHER, LOCK M10	4	
41%	416121010	VAS HANDLE BODY	1	

BODY ASSY. (CONTINUED)

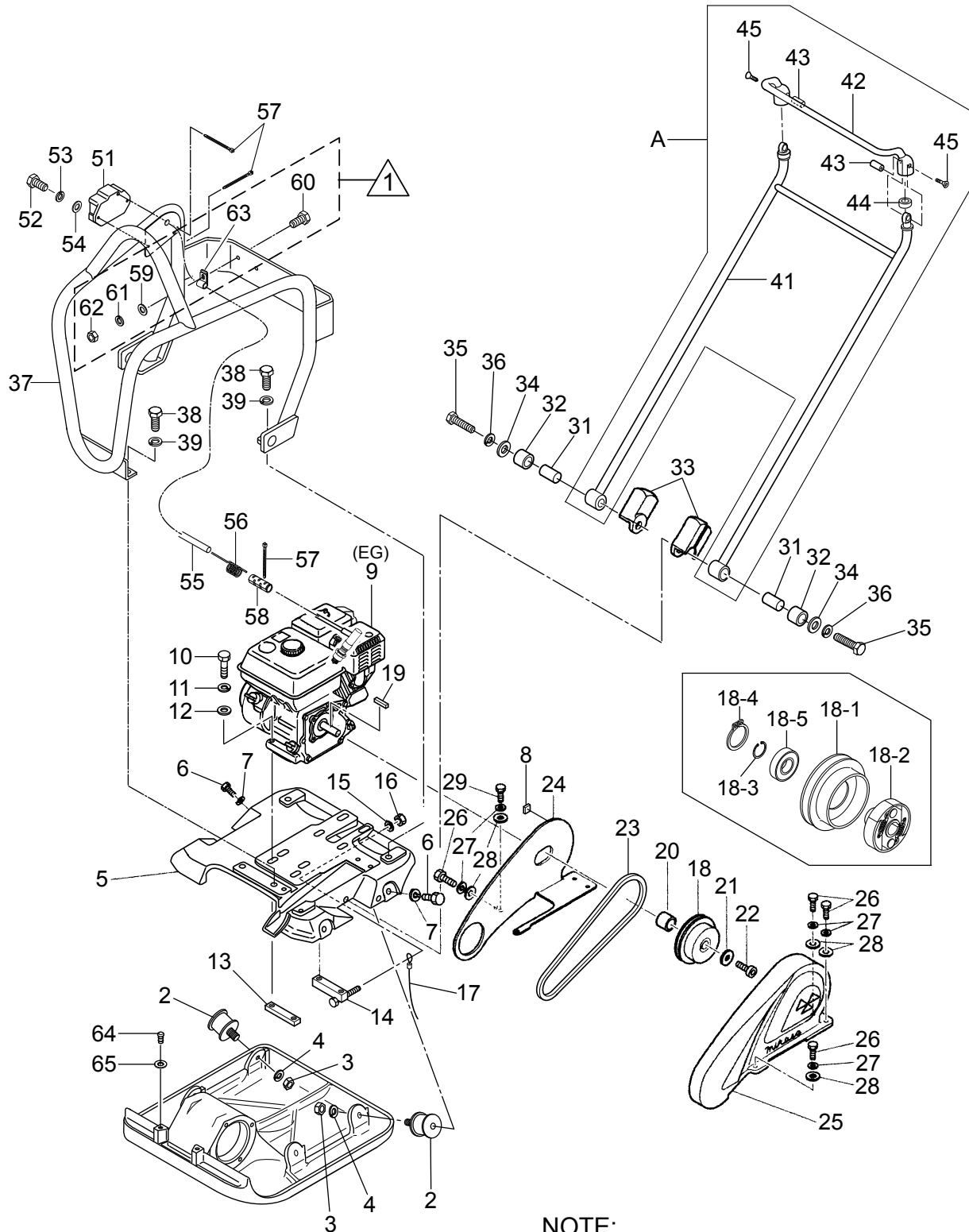

NOTE:
 1 ITEMS 59 THROUGH 62
 NOT REQUIRED WHEN CYCLONE
 AIR CLEANER INSTALLED
 (S/N T2A9198 AND ABOVE)

BODY ASSY. (CONTINUED)

<u>NO.</u>	<u>PART NO.</u>	<u>PART NAME</u>	<u>QTY.</u>	<u>REMARKS</u>
42%	416218770	GRIP, VAS HANDLE	1	
43%	416459320	HANDLE NUT, VAS HANDLE	2	
44%	416459340	RUBBER, VAS HANDLE	2	
45%	009120407	SUNK HEAD BOLT 10X20	2	
51	955010311	TACH/HOUR METER	1	
52	001220510	BOLT 5X10	2	
53	030205130	WASHER, LOCK M5	2	
54	58151	WASHER, FLAT M5	2	
55	959026822	RUBBER TUBE	1	
56	955010310	CURL CORD	1	
57	507010110	CLAMP	3	
58	955010307	CLIP BELT	1	
59	952404470	WASHER, FLAT M6.....	1	S/N T2A9197 AND BELOW
60	0105050616	BOLT 6X15	1	S/N T2A9197 AND BELOW
61	030206150	WASHER, LOCK M6.....	1	S/N T2A9197 AND BELOW
62	020106050	NUT M6.....	1	S/N T2A9197 AND BELOW
63	2067550101	CLAMP COMPLETE.....	1	S/N T2A9197 AND BELOW
64	001221215	BOLT 12X15	2	
65	031112230	WASHER, FLAT M12	2	

BASE PLATE/VIBRATOR ASSY.

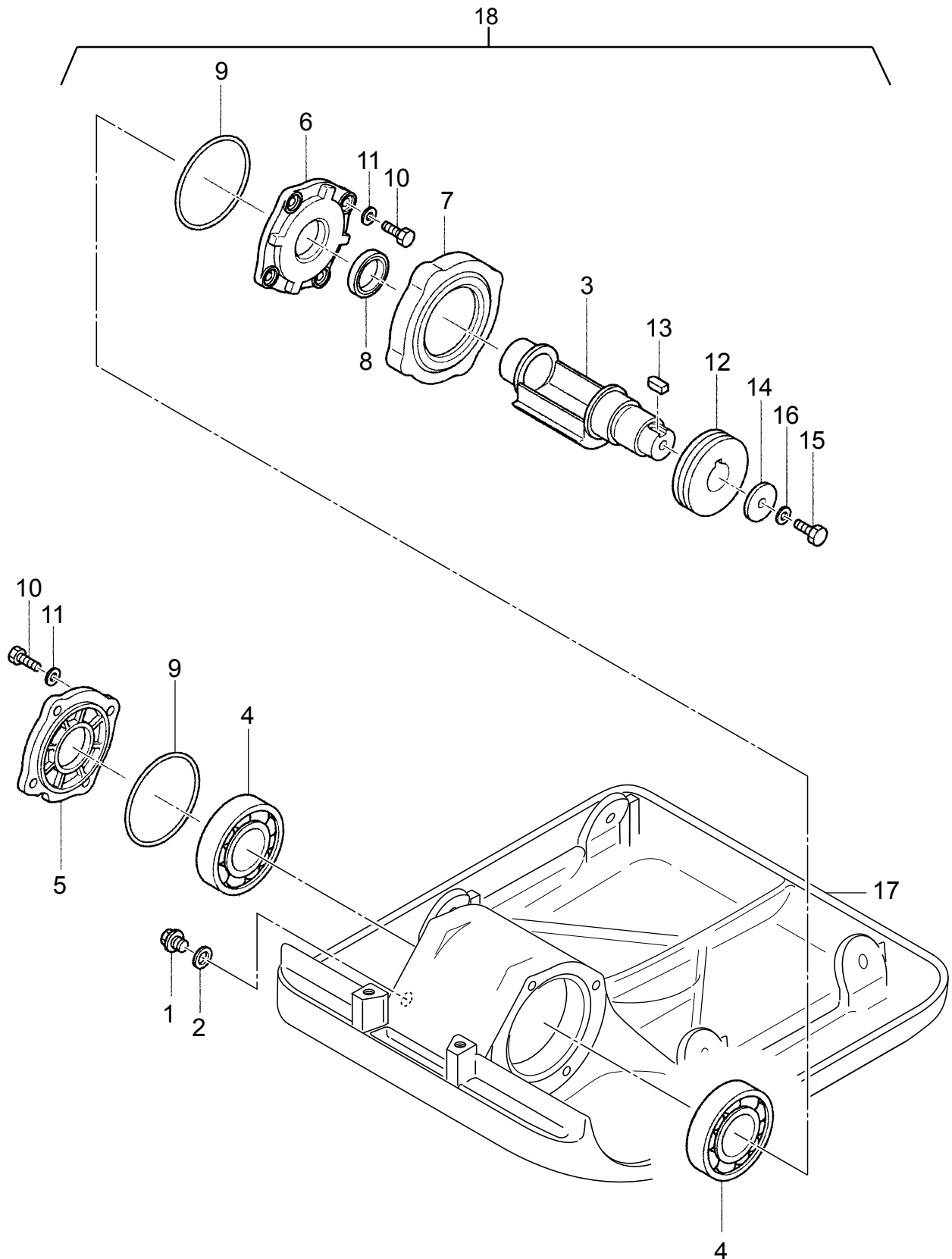

BASE PLATE/VIBRATOR ASSY.

<u>NO.</u>	<u>PART NO.</u>	<u>PART NAME</u>	<u>QTY.</u>	<u>REMARKS</u>
1#	953405270	PLUG 1/4X14 X13L	1	
2#	953405260	PACKING 1/4"	1	
3#	416218390	ECCENTRIC ROTATOR	1	
4#	040406211	BEARING 6211	2	
5#	416338909	CASE COVER (R)	1	
6#	416338919	CASE COVER (L)	1	
7#	416349930	BELT COVER GUARD	1	
8#	060203030	OIL SEAL	1	
9#	050101000	O-RING	2	
10#	014208020	BOLT 8X20	8	
11#	030208200	WASHER, LOCK M8	8	
12#	416464470	PULLEY, VIBRATOR ASSY.	1	
13#	951405240	KEY 7X7X19	1	
14#	952404250	WASHER 11X40X4	1	
15#	0105091025	BOLT 10X25	1	
16#	030210250	WASHER, LOCK M10	1	
17#	416120141	VIBRATING PLATE	1	
18	416910150	VIBRATING PLATE ASSY.....	1.....	INCLUDES ITEMS W/#

TRANSPORT WHEEL ASSY. (OPTION)

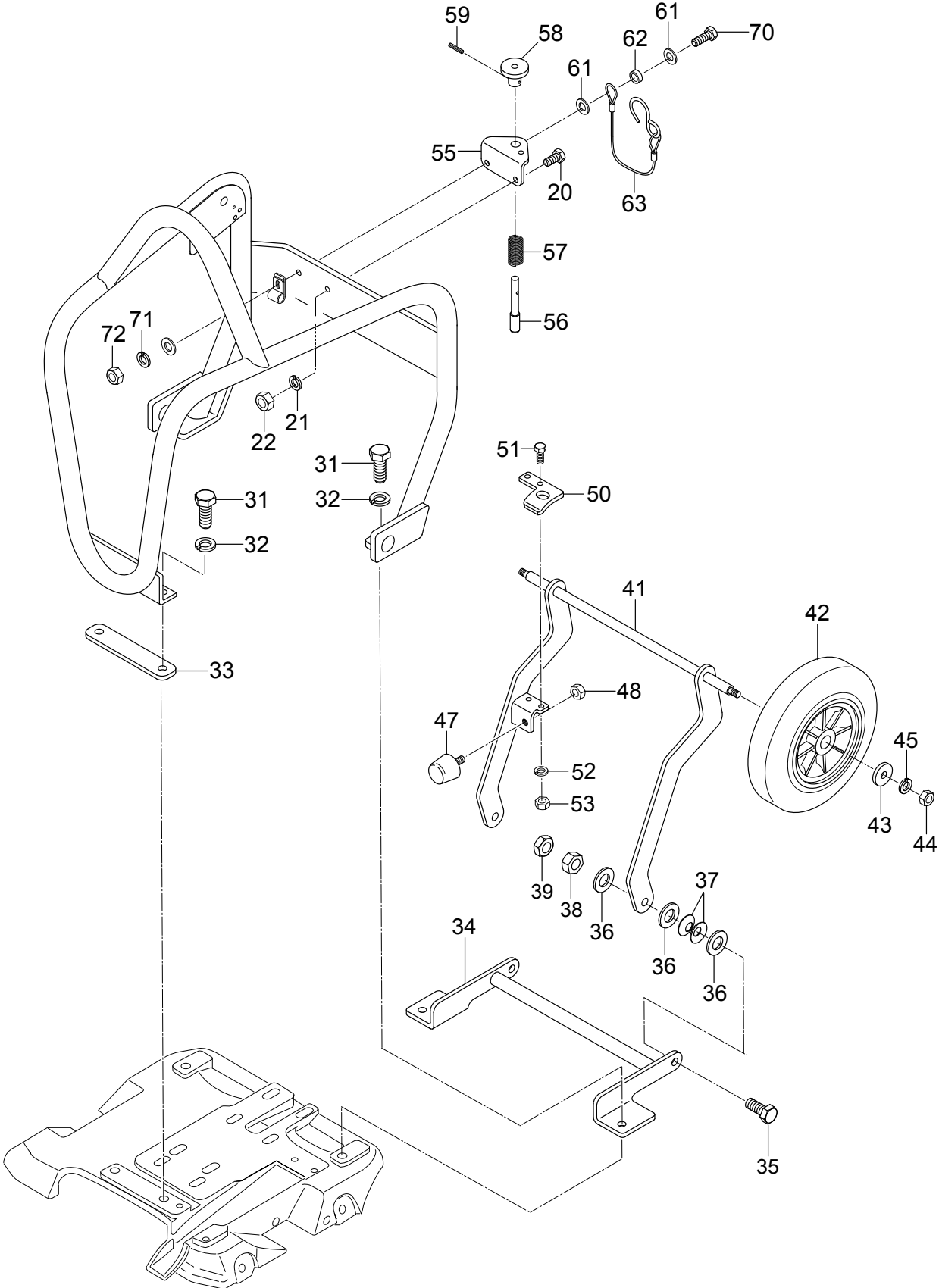

TRANSPORT WHEEL ASSY. (OPTION)

<u>NO.</u>	<u>PART NO.</u>	<u>PART NAME</u>	<u>QTY.</u>	<u>REMARKS</u>
20	0105050616	BOLT 6X15	1	
21	030206150	WASHER, LOCK M6	1	
22	020106050	NUT M6	1	
31	012010030	BOLT 10X30	4	
32	030210250	WASHER, LOCK M10	4	
33	416466680	SPACER, WHEEL	1	
34	416352490	BRACKET, WHEEL	1	
35	012210035	BOLT 10X35	2	
36	031110160	WASHER, FLAT M10	6	
37	032110180	CONICAL LOCK WASHER	4	
38	020310080	NUT M10	2	
39	020310080	NUT M10	2	
41	416218830	AXLE, TRANSPORT WHEEL, WHL88T	1	S/N T2A9197 AND BELOW
41	416219520	AXLE, TRANSPORT WHEEL, WHL88TC.....	1	S/N AND T2A9198 ABOVE
42	959301000	WHEEL	2	
43	952400130	SPACER	2	
44	020108060	NUT M8	2	
45	030208200	WASHER, LOCK M8	2	
47	939010270	STOPPER RUBBER	1	
48	020108060	NUT M8	1	
50	416467230	STOPPER, LOCK PIN	1	
51	011206020	BOLT 6X20	2	
52	030206150	WASHER, LOCK M6	2	
53	020106050	NUT M6	2	
55	416351700	LOCK BRACKET, WHEEL	1	
56	416466690	LOCK PIN, WHEEL	1	
57	458450880	SPRING	1	
58	416467240	LOCK KNOB, WHEEL	1	
59	025403016	SPRING PIN 3X16	1	
61	952408960	WASHER, FLAT 6.5X16X1	2	
62	952408980	COLLAR 6.2X9X4	1	
63	419466670	LOCK WIRE, HANDLE	1	
70	011606025	BOLT 6X25	1	
71	030206150	WASHER, LOCK M6	1	
72	020106050	NUT M6	1	

SPRINKLER ASSY.

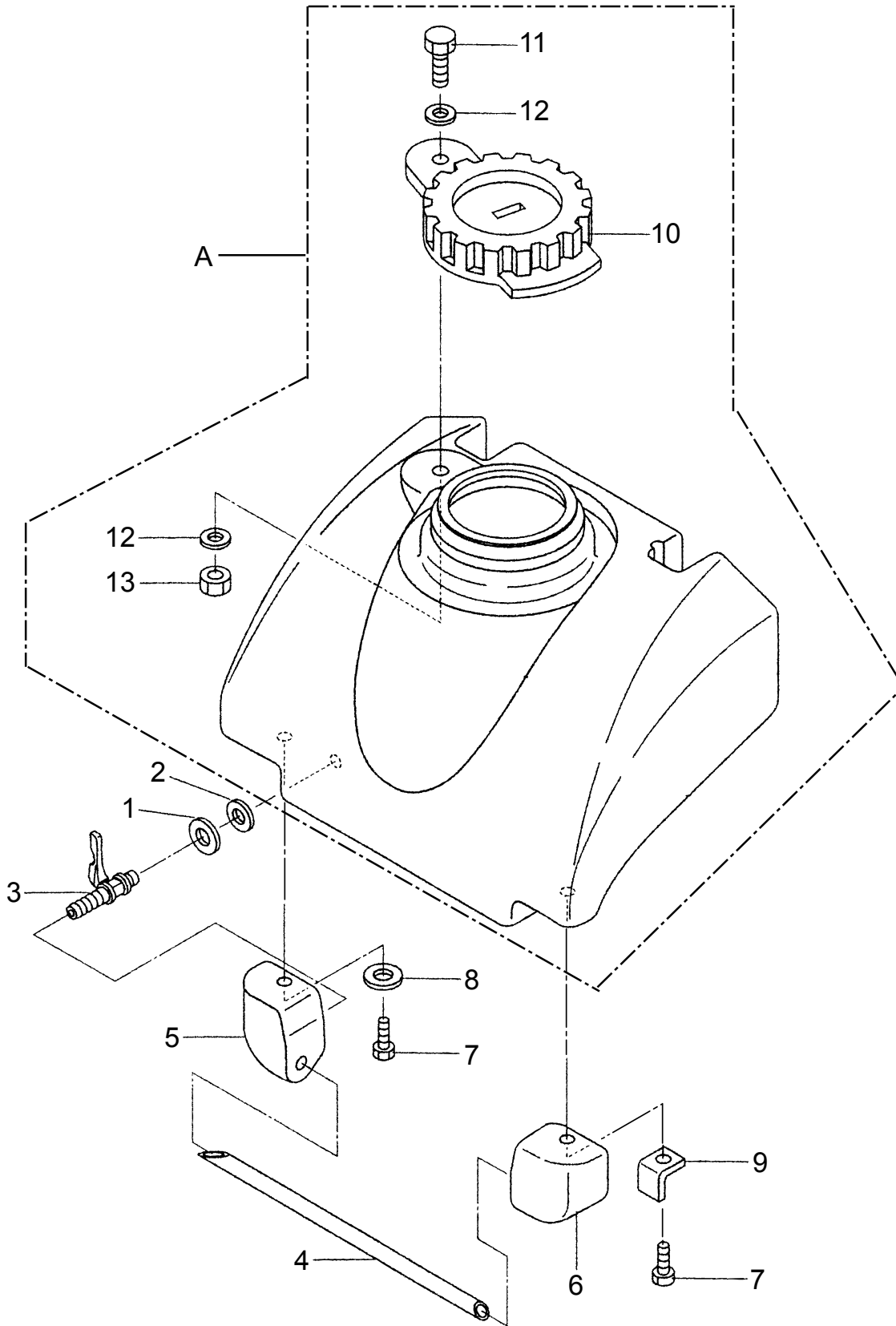

SPRINKLER ASSY.

<u>NO.</u>	<u>PART NO.</u>	<u>PART NAME</u>	<u>QTY.</u>	<u>REMARKS</u>
A	416910110	WATER TANK W/CAP	1	INCLUDES ITEMS W/%
1	033910050	WASHER 14.5X30X1.6	1	
2	953406390	PACKING 13X28X2	1	
3	954403241	COCK PT 1/4"	1	
4	416338930	SPRINKLING PIPE	1	
5	416338940	PIPE HOLDER (L)	1	
6	416452750	PIPE HOLDER (R)	1	
7	001220825	BOLT 8X25	2	
8	0401450080	WASHER, FLAT M8	1	
9	416452790	STAY, PIPE HOLDER	1	
10%	954300342	CAP, WATER TANK	1	
11%	001241030	BOLT 10X30	1	
12%	033910160	WASHER, FLAT M10	2	
13%	022910270	NUT M10	1	

URETHANE PLATE ASSY. (OPTION)

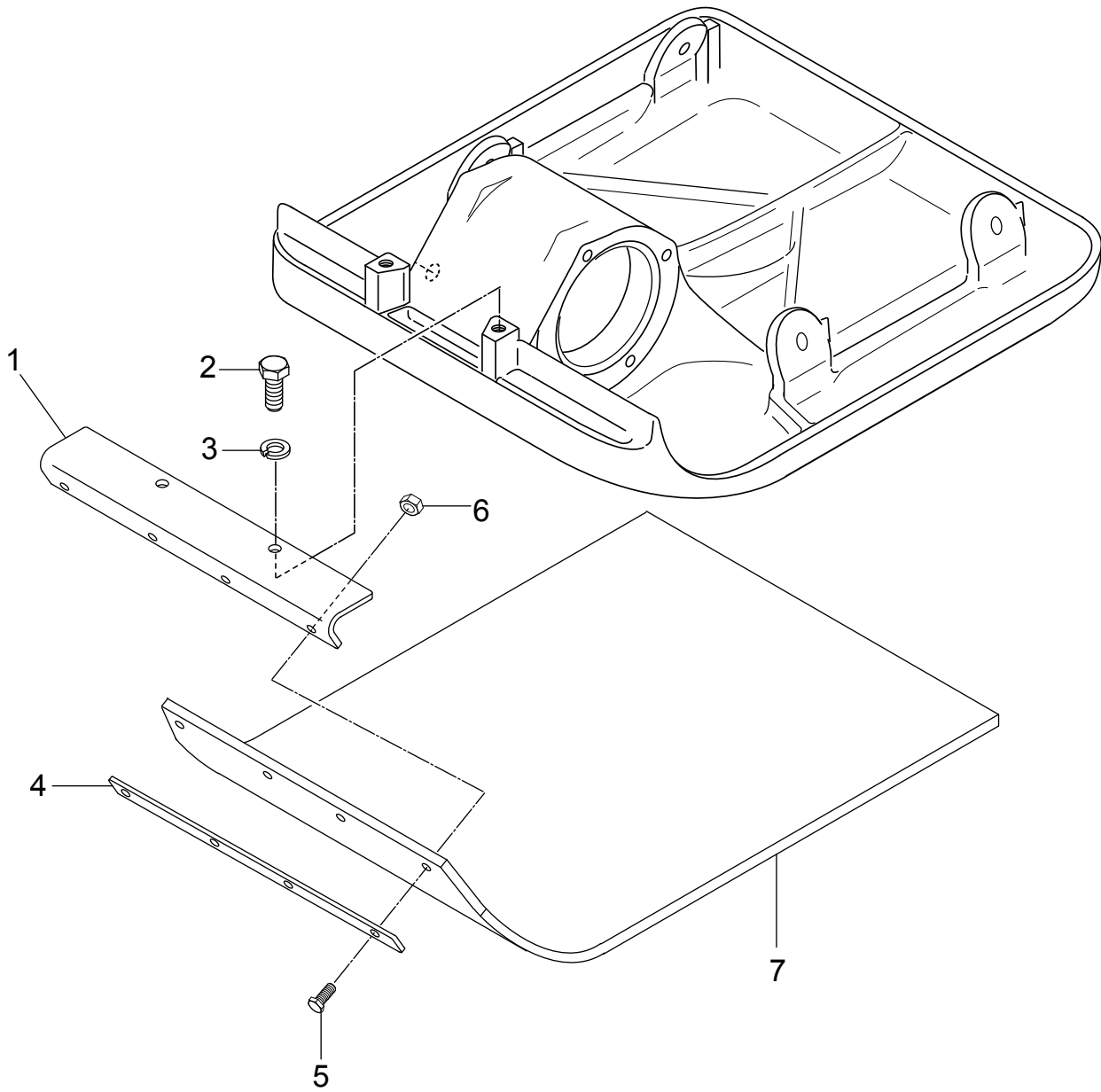

URETHANE PLATE ASSY. (OPTION)

<u>NO.</u>	<u>PART NO.</u>	<u>PART NAME</u>	<u>QTY.</u>	<u>REMARKS</u>
1	416352080	HANGER, URETHANE PLATE	1	
2	001221230	BOLT 12X30	2	
3	012012030	WASHER, LOCK M12	2	
4	416352090	PLATE, URETHANE PLATE	1	
5	011208035	BOLT 8X35	4	
6	022710809	NYLON NUT M8	4	
7	PADUPA88	PAD, URETHANE	1.....	REPLACES P/N 416342390

NAMEPLATE AND DECALS ASSY.

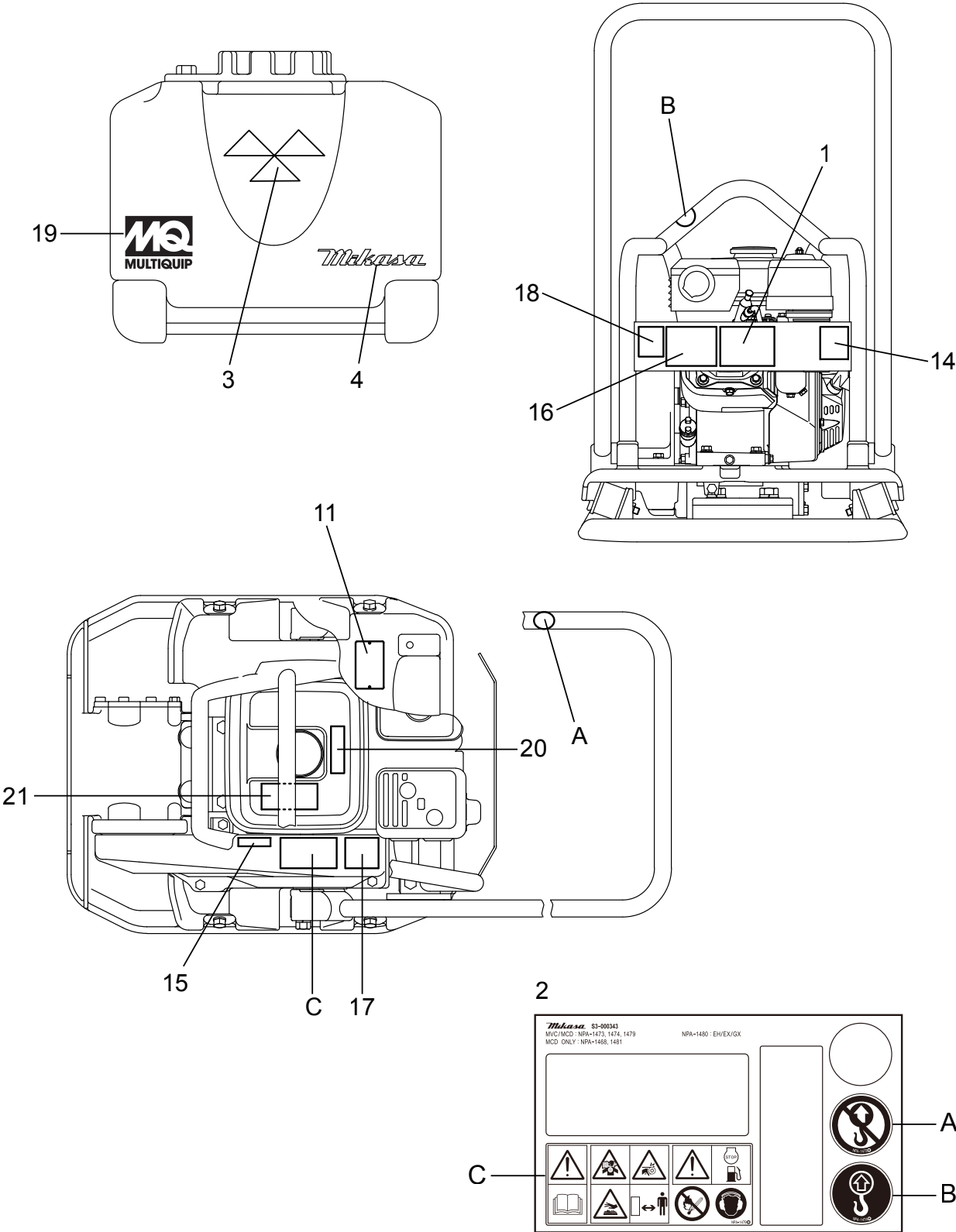

NAMEPLATE AND DECALS ASSY.

<u>NO.</u>	<u>PART NO.</u>	<u>PART NAME</u>	<u>QTY.</u>	<u>REMARKS</u>
1	920218170	DECAL, POSITION	1	
2	920900090	DECAL, SET	1.....	SET ONLY
3	920101410	DECAL, MIKASA MARK 120X60	1	
4	920105070	DECAL, MIKASA MARK 125MM	1	
11	920217430	PLATE, SERIAL NO./88VTH	1	
11	920217440	PLATE, SERIAL NO./88VTHW	1	
14	920210330	DECAL, EC NOISE REQ.LWA105	1	
15	920208350	DECAL, V-BELT RPF3330	1	
16	920203290	DECAL, CAUTION	1	
17	920203060	DECAL, CAUTION	1	
18	920206290	DECAL, CAUTION (MANUAL/EXP)	1	
19	920201580	DECAL, MQ MARK 71X55	1	
20	920214100	DECAL ,E/G FIRE WARNING	1	
21	920212320	DECAL, FUEL CAUTION	1	

HONDA GX160UT2QMX2/QMXC ENG. — CYL. HEAD ASSY.

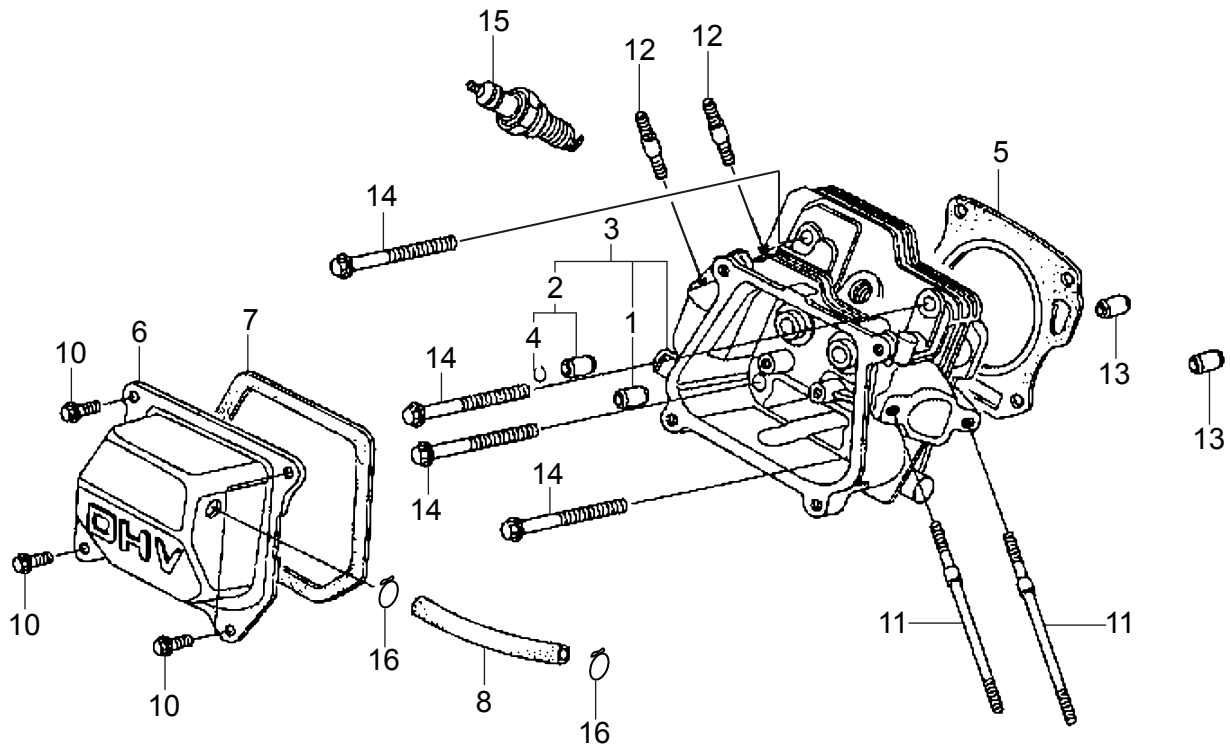

HONDA GX160UT2QMX2/QMXC ENG. — CYL. HEAD ASSY.

NO.	PART NO.	PART NAME	QTY.	REMARKS
1%	12204ZE1306	GUIDE, INLET VALVE (O.S.)	1	
2%	12205ZE1315	GUIDE, EXHAUST VALVE (O. S.).....	1	INCLUDES ITEMS W/\$
3	12210Z4M405	HEAD COMP, CYLINDER.....	1	INCLUDES ITEMS W/%
4\$%	12216ZE5300	CLIP, VALVE GUIDE	1	
5	12251ZL0003	GASKET, CYLINDER HEAD	1	
6	12310Z4M000	COVER CP, HEAD	1	
6◇	12310Z4M840	COVER CP, HEAD	1	
7	12391ZE1000	PACKING, HEAD COVER	1	
8	15721ZH8000	TUBE, BREATHER	1	
8◇	15721ZH1840	TUBE, BREATHER	1	
10	90013883000	FLANGE BOLT 6X12	4	
11	90043ZE1020	STUD BOLT 6X112	2	
12	90047ZE1000	STUD BOLT 8X32	2	
13	9430110160	KNOCK PIN 10X16	2	
14	957010806000	BOLT, FLANGE 8X60	4	
15	0650140480	SPARK PLUG, EY45V	1	
16◇	9500280000	CLIP, TUBE	2	

NOTICE

GX160UT2QMX2

◇ GX160UT2QMXC

HONDA GX160UT2QMX2/QMXC ENG. — CYL. BARREL ASSY.

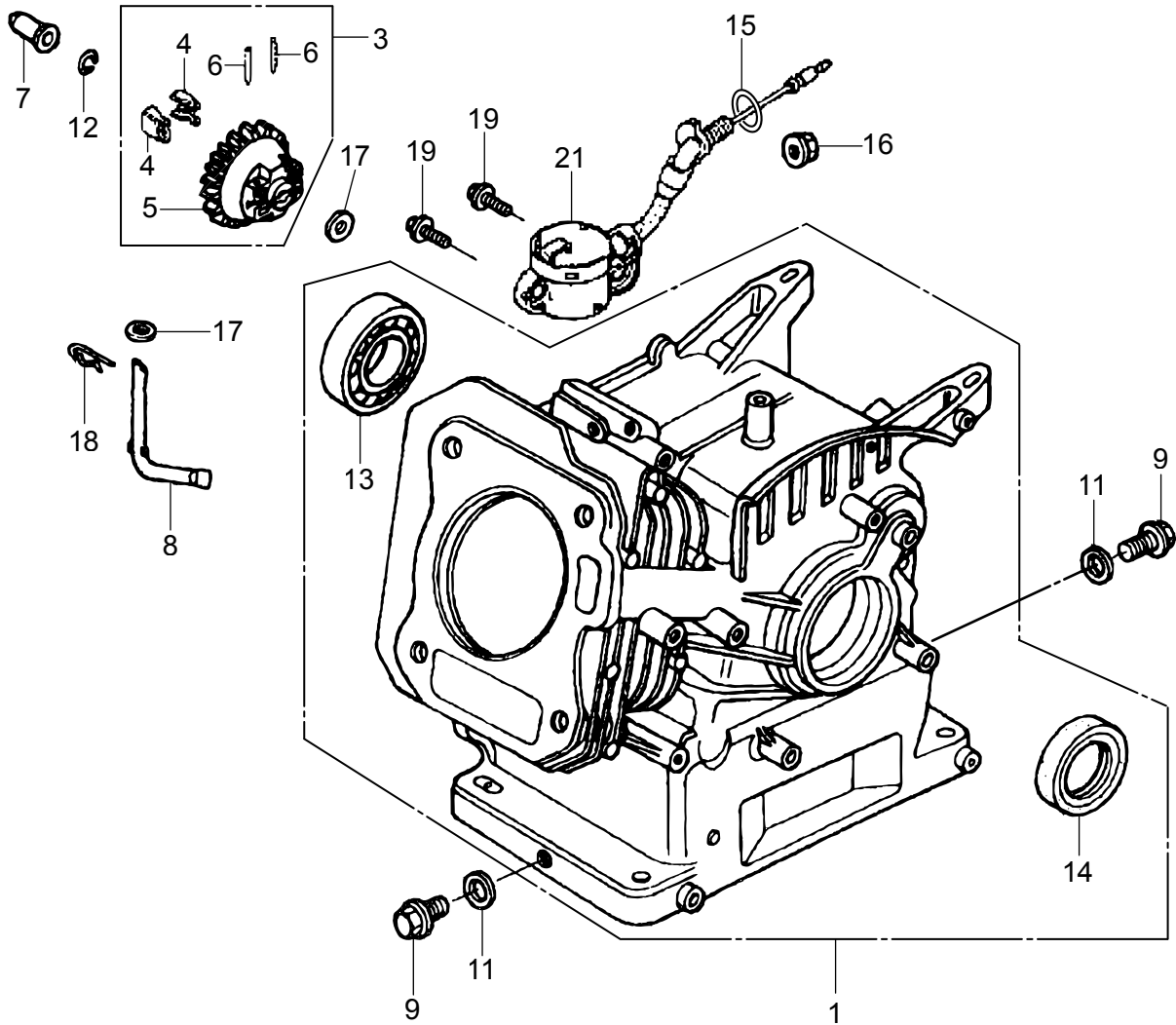

HONDA GX160UT2QMX2/QMXC ENG. — CYL. BARREL ASSY.

NO.	PART NO.	PART NAME	QTY.	REMARKS
1	12000Z4M406	BARREL, ASSY CYLINDER (OIL ALERT)	1	INCLUDES ITEMS W/\$
1◇	12000Z4M416	BARREL, ASSY CYLINDER (OIL ALERT)	1	INCLUDES ITEMS W/\$
3	16510Z4M000	GOVERNOR ASSY.	1	INCLUDES ITEMS W/%
4%	16511Z4M000	WEIGHT, GOVERNOR	2	
5%	16512Z4M000	HOLDER, GOVERNOR WEIGHT	1	
6%	16513ZE1000	PIN, GOVERNOR WEIGHT	2	
7	16531Z4M000	SLIDER, GOVERNOR	1	
8	16541Z4M000	SHAFT, GOVERNOR ARM	1	
9	90131ZE1000	BOLT, DRAIN PLUG	2	
11	90601ZE1000	WASHER, DRAIN PLUG	2	
12	90602ZE1000	CLIP, GOVERNOR HOLDER	1	
13\$	91001ZF1003	BALL BEARING 6205	1	
14\$	91201Z0T801	OIL SEAL 25X41X6	1	
15	91353671004	O-RING 14MM	1	
16	9405010000	FLANGE NUT M10	1	
17	9410106800	WASHER, PLAIN 6MM	2	
18	9425108000	LOCK PIN 8MM	1	
19	957010601200	FLANGE BOLT 6X12	2	
21	35480Z0T003	SWITCH ASSY., OIL LEVEL	1	

NOTICE

GX160UT2QMX2

◇ GX160UT2QMXC

HONDA GX160UT2QMX2/QMXC ENG. — CRANKCASE CVR. ASSY.

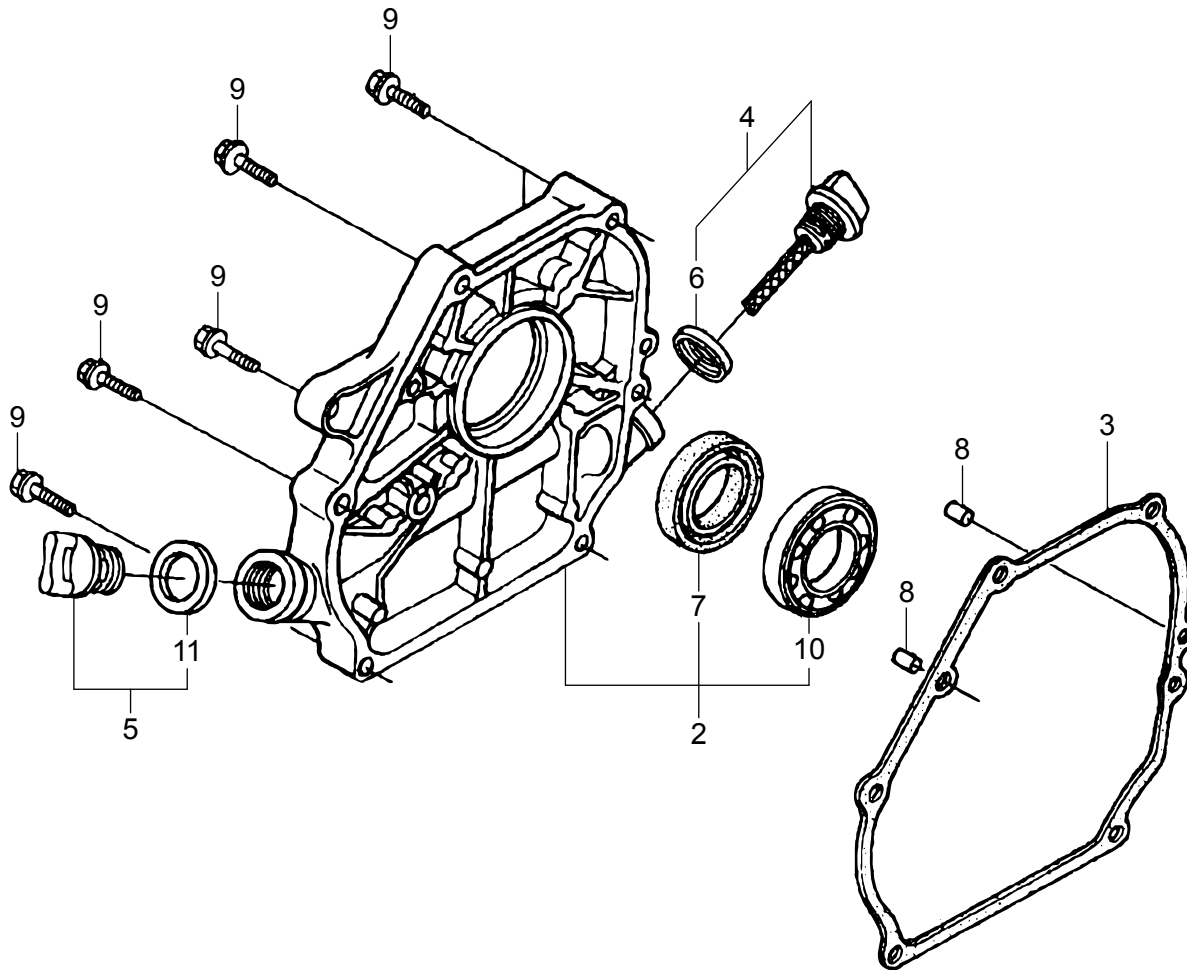

HONDA GX160UT2QMX2/QMXC ENG. — CRANKCASE CVR. ASSY.

<u>NO.</u>	<u>PART NO.</u>	<u>PART NAME</u>	<u>QTY.</u>	<u>REMARKS</u>
2	11300Z4M640	COVER, ASSY. CRANKCASE	1.....	INCLUDES ITEMS W/#
3	11381ZH8801	GASKET CRANKCASE	1	
4	15600Z0T810	CAP ASSY. OIL FILLER	1.....	INCLUDES ITEMS W/\$
5	15600Z0T820	CAP ASSY. OIL FILLER.....	1.....	INCLUDES ITEMS W/%
6\$	15625Z0T800	PACKING, OIL FILLER CAP	1	
7#	91201Z0T801	OIL SEAL 25X41X6	1	
8	9430108140	KNOCK PIN 8X14	2	
9	957010803200	FLANGE BOLT 8X32	6	
10#	961006205000	BALL BEARING 6205	1	
11%	15625Z0T800	PACKING, OIL FILLER CAP	1	

HONDA GX160UT2QMX2/QMXC ENG. — CRANKSHAFT ASSY.

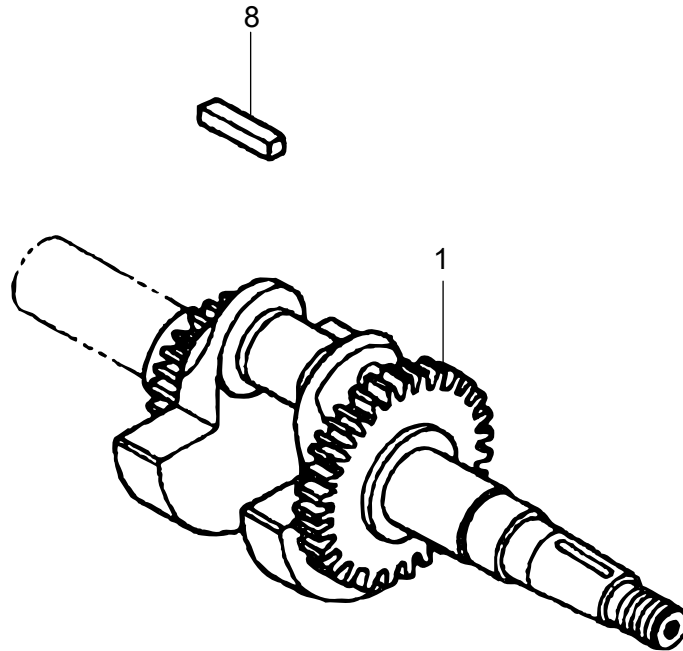

HONDA GX160UT2QMX2/QMXC ENG. — CRANKSHAFT ASSY.

<u>NO.</u>	<u>PART NO.</u>	<u>PART NAME</u>	<u>QTY.</u>	<u>REMARKS</u>
1	13310Z4M800	CRANK SHAFT COMPLETE	1	
8	90745ZE1600	KEY 4.78X4.78X38	1	

HONDA GX160UT2QMX2/QMXC ENGINE — PISTON ASSY.

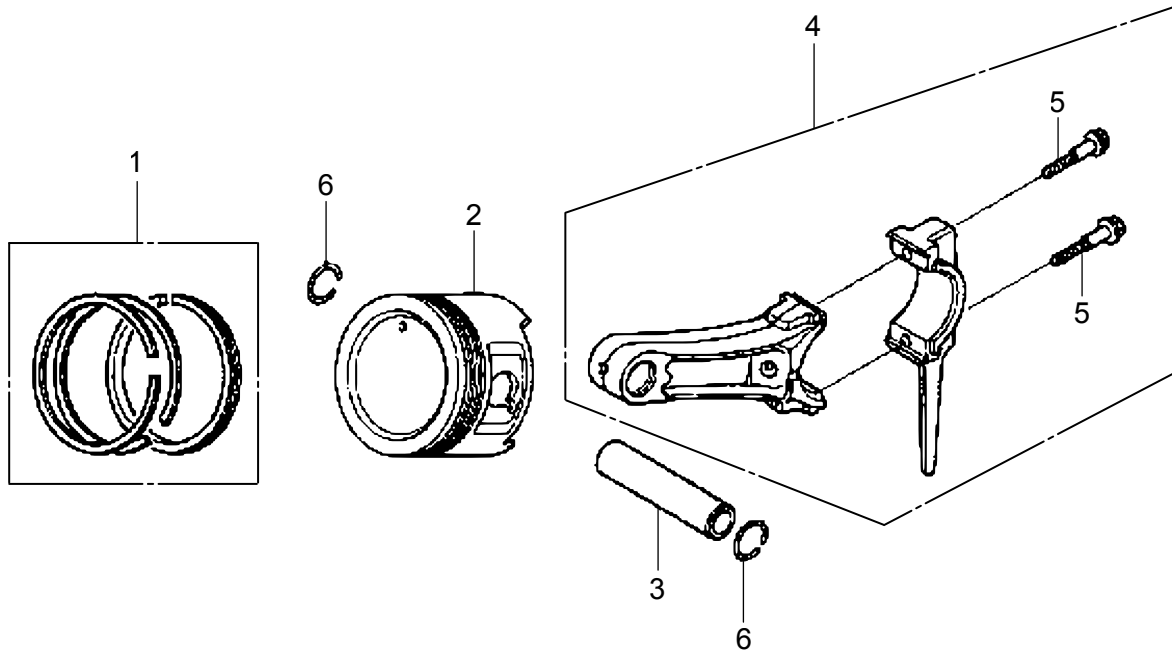

HONDA GX160UT2QMX2/QMXC ENGINE — PISTON ASSY.

NO.	PART NO.	PART NAME	QTY.	REMARKS
1	13010Z4M801	RING SET, PISTON (STD)	1	
2	13101Z4M800	PISTON (STD)	1	
3	13111Z4M000	PIN, PISTON	1	
4	13200Z4M000	ROD AY, CONNECTING.....	2.....	INCLUDES ITEMS W\$
4◇	13200Z0T900	ROD AY, CONNECTING.....	2.....	INCLUDES ITEMS W\$
5\$	90001Z4M000	BOLT, CONNECTING ROD 6X34.5	2	
6	90551ZE1000	CLIP, PISTON PIN 18MM	2	

NOTICE

GX160UT2QMX2

◇ GX160UT2QMXC

HONDA GX160UT2QMX2/QMXC ENG. — CAMSHAFT ASSY.

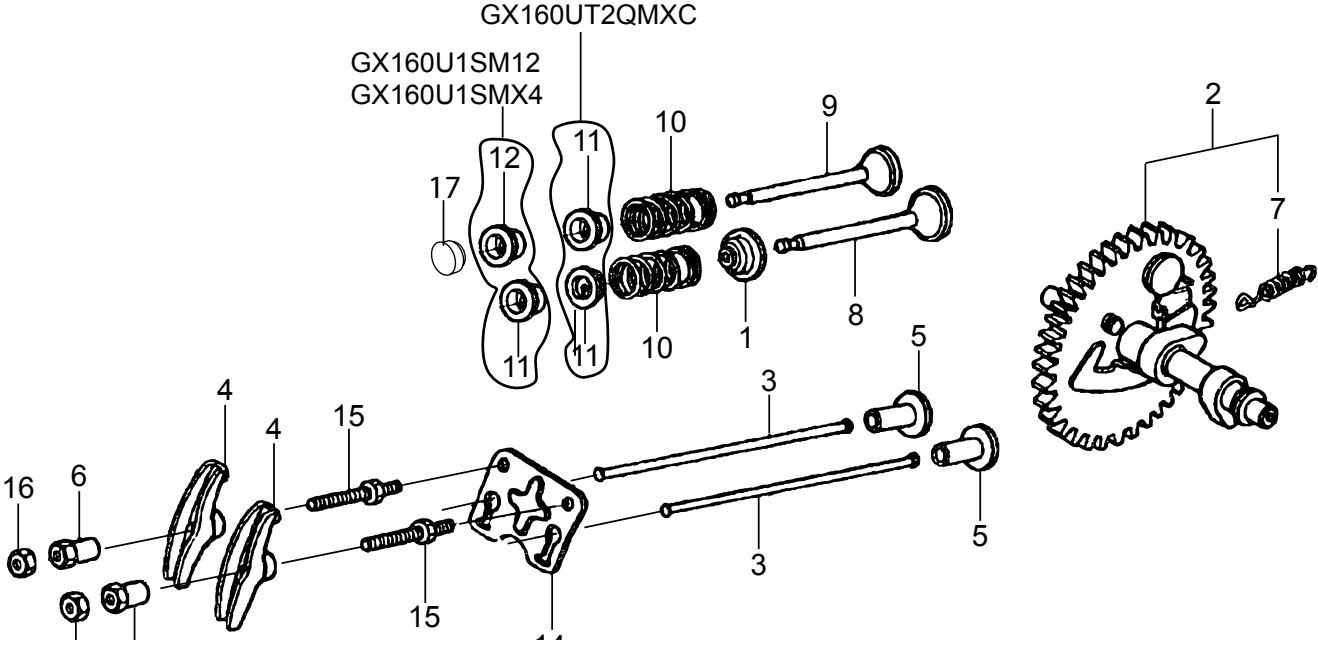

HONDA GX160UT2QMX2/QMXC ENG. — CAMSHAFT ASSY.

NO.	PART NO.	PART NAME	QTY.	REMARKS
1	12209Z4M801	SEAL, VALVE STEM	1	
2	14100Z4M000	CAMSHAFT ASSY.....	1	INCLUDES ITEM W/\$
3	14410Z4M000	ROD CP, PUSH	2	
4	14431ZE1000	ARM, VALVE ROCKER	2	
5	14441ZE1010	VALVE LIFTER	2	
6	14451ZE1013	PIVOT, ROCKER ARM	2	
6◇	14451Z4M000	PIVOT, ROCKER ARM	2	
7\$	14568ZE1000	SPRING, WEIGHT RETURN	1	
8	14711Z4M000	VALVE, INTAKE	1	
9	14721Z4M000	VALVE, EXHAUST	1	
10	14751ZF1000	SPRING, VALVE	2	
11	14771ZE1000	RETAINER, INTAKE VALVE	1	
11◇	14771Z0T900	RETAINER, INTAKE VALVE	2	
12	14773ZE1000	RETAINER, EXHAUST VALVE	1	
14	14791Z4M000	PLATE, PUSH ROD GUIDE	1	
15	90012ZE0010	BOLT, PIVOT, 8MM	2	
16	90206ZE1000	NUT, PIVOT ADJUSTING	2	

NOTICE

GX160UT2QMX2

◇ GX160UT2QMXC

HONDA GX160UT2QMX2/QMXC ENG. — RECOIL STR. ASSY.

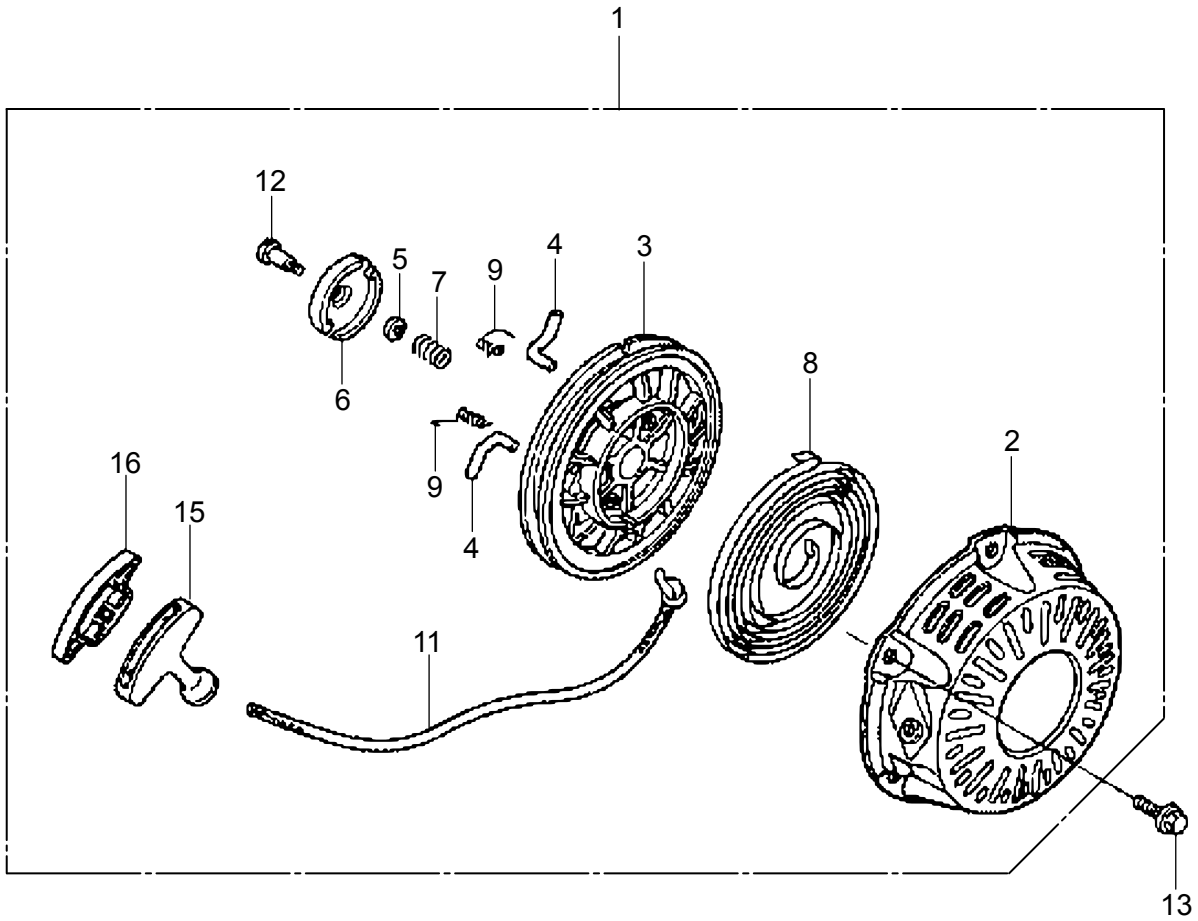

HONDA GX160UT2QMX2/QMXC ENG. — RECOIL STR. ASSY.

<u>NO.</u>	<u>PART NO.</u>	<u>PART NAME</u>	<u>QTY.</u>	<u>REMARKS</u>
1	28400Z4M305ZD	STARTER ASSY., RECOIL	1.....	INCLUDES ITEMS W/\$
2\$	28410Z4M003ZD	CASE CP, STARTER	1	
3\$	28421Z0T003	REEL, RECOIL STARTER	1	
4\$	28422ZH8801	RATCHET, STARTER	2	
5\$	28431ZH8801	PLATE, FRICTION	1	
6\$	28433ZH8801	RATCHET GUIDE	1	
7\$	28441ZH8801	FRICTION SPRING	1	
8\$	28442ZH8003	SPRING, RECOIL STARTER	1	
9\$	28443ZH8801	SPRING, RETURN	2	
11\$	28462ZH8003	ROPE, RECOIL STARTER	1	
12\$	90003ZH8801	SET SCREW	1	
13	90008ZE2003	BOLT, FLANGE 6X10	3	
15\$	28461Z4M305	KNOB, RECOIL STARTER	1	
16\$	28463Z4M003	KNOB, REINFORCEMENT	1	

HONDA GX160UT2QMX2/QMXC ENG. — FAN COVER ASSY.

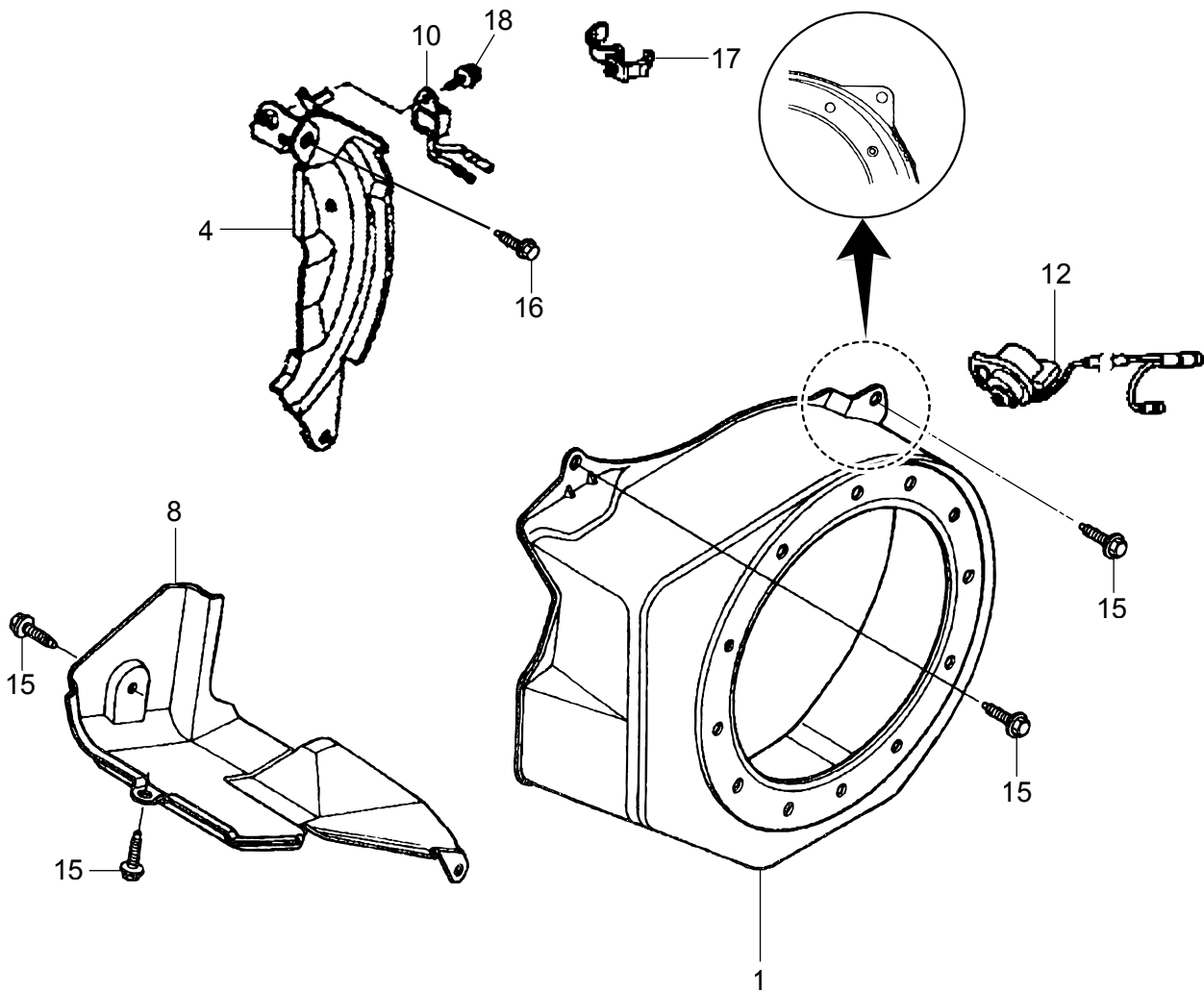

HONDA GX160UT2QMX2/QMXC ENG. — FAN COVER ASSY.

<u>NO.</u>	<u>PART NO.</u>	<u>PART NAME</u>	<u>QTY.</u>	<u>REMARKS</u>
1	19610Z4M000ZB	COVER COMPLETE	1	
4	19611Z4M810	PLATE CP, SIDE (OIL ALERT)	1	
8	19630Z4M000	SHROUD COMPLETE	1	
10	34150ZH7013	ALERT, UNIT, OIL	1	
12	35120Z0T851	SWITCH AY, E/G STOP	1	
15	90013883000	FLANGE BOLT 6X12	6	
16	90022888010	FLANGE BOLT 6X20	1	
17	90601ZH7013	CLIP, HARNESS	1	
18	957010600800	FLANGE BOLT 6X8	1	

HONDA GX160UT2QMX2/QMXC ENG. — CARB. ASSY.

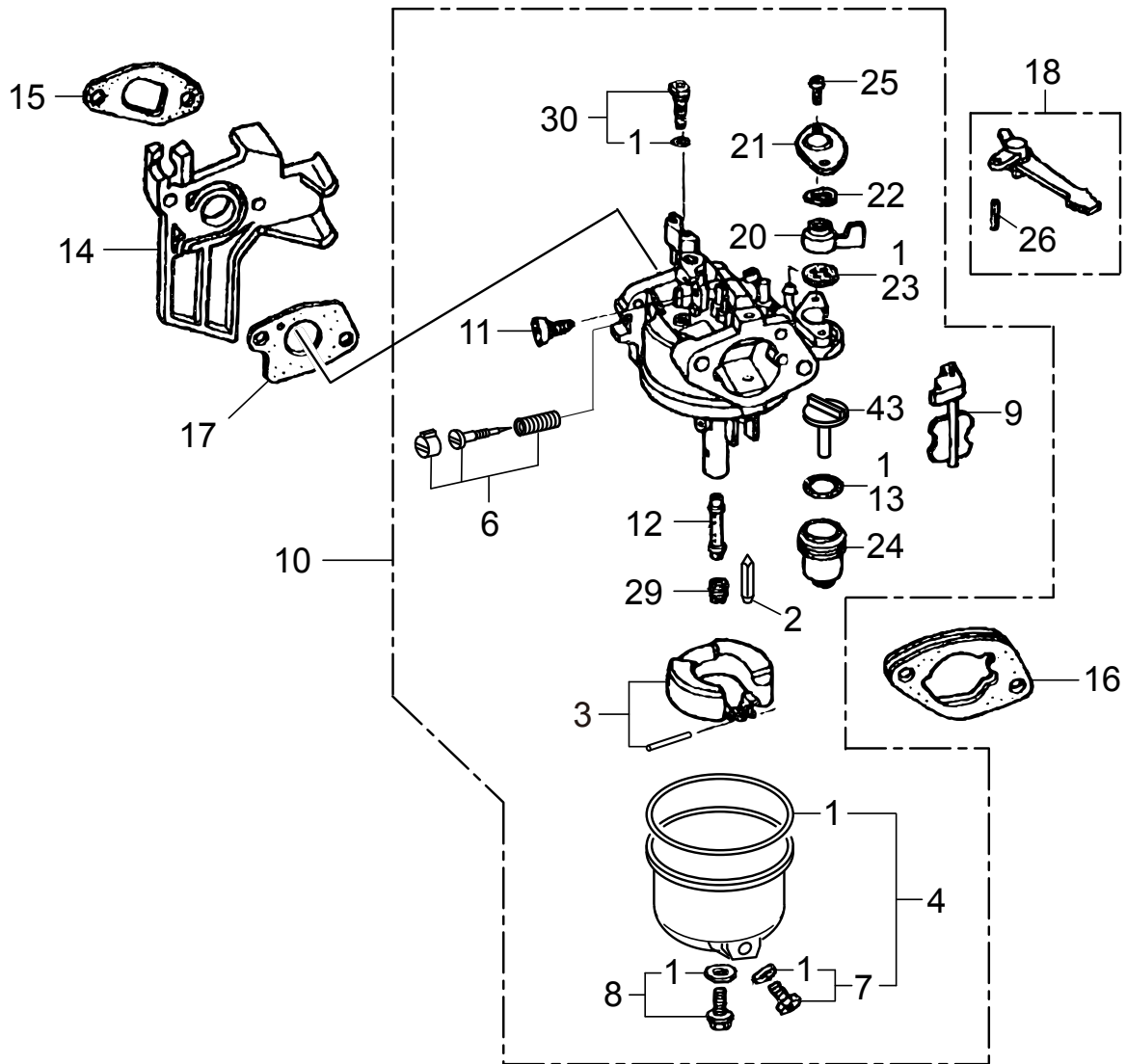

HONDA GX160UT2QMX2/QMXC ENG. — CARB. ASSY.

NO.	PART NO.	PART NAME	QTY.	REMARKS
1#@+&^	16010ZE1812	GASKET SET	1	
2#	16011ZE0005	FLOAT VALVE SET	1	
3#	16013Z0SB01	FLOAT SET	1	
4#	16015Z4M911	CHAMBER SET, FLOAT	1	INCLUDES ITEMS W/+
6#	16016ZH7W01	SCREW SET, PILOT	1	
7#+	16024Z5T901	SCREW SET, DRAIN	1	INCLUDES ITEMS W/^
8#	16028Z5T901	SCREW SET	1	INCLUDES ITEMS W/&
9#	16044Z4M911	CHOKE SET	1	
10	16100Z4M911	CARBURETOR ASSY.....	1	INCLUDES ITEMS W/#
10◇	16100Z4MV22	CARBURETOR ASSY.....	1	INCLUDES ITEMS W/#
11#	16124ZE0005	SCREW, THROTTLE STOP	1	
12#	16166Z4M911	NOZZLE, MAIN	1	
12#◇	16166Z4MV21	NOZZLE, MAIN	1	
13#	16173001004	PACKING, CUP	1	
14	16211Z4M000	INSULATOR, CARBURETOR	1	
15	16212ZH8800	PACKING, INSULATOR	1	
16#	16220ZE1020	SPACER COMP., CARBURETOR	1	
17	16221ZH8801	PACKING, CARBURETOR	1	
18	16610ZE1000	CHOKE LEVER COMP.....	1	INCLUDES ITEMS W/%
20#	16953ZE1812	LEVER, COCK	1	
21#	16954ZE1812	PLATE, LEVER SETTING	1	
22#	16956ZE1811	SPRING, COCK LEVER	1	
23#	16957ZE1812	PACKING, FUEL COCK	1	
24#	16967ZE0811	CUP, FUEL STRAINER	1	
25#	93500030060H	SCREW 3X6	2	
25#◇	93500030061H	SCREW 3X6	2	
26%	9430520122	SPRING PIN 2X12	1	
29#	99101ZH80700	MAIN JET #70	1	
30#	99204ZE00350	PILOT JET SET 835.....	1	INCLUDES ITEMS W/@
30#◇	99204ZE00380	PILOT JET SET 835.....	1	INCLUDES ITEMS W/@
43#	16959Z5T901	FILTER, CUP	1	

NOTICE

GX160UT2QMX2

◇ GX160UT2QMXC

HONDA GX160UT2QMX2 ENGINE — AIR CLEANER ASSY.

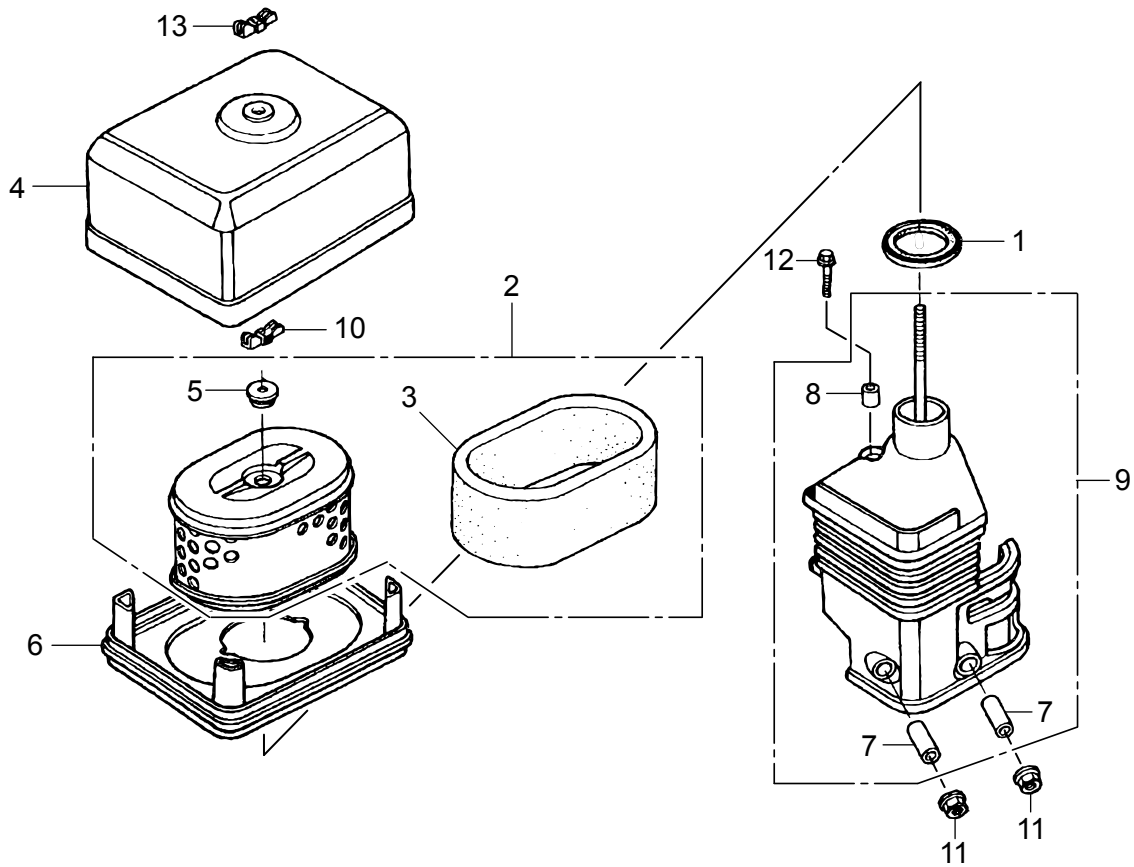

HONDA GX160UT2QMX2 ENGINE — AIR CLEANER ASSY.

<u>NO.</u>	<u>PART NO.</u>	<u>PART NAME</u>	<u>QTY.</u>	<u>REMARKS</u>
1	16271ZE1000	PACKING, ELBOW	1	
2	17210ZE1517	CLEANER ELEMENT	1.....	INCLUDES ITEMS W/#
3#	17218ZE1507	OUTER ELEMENT	1	
4	17231Z4M010	COVER, AIR CLEANER	1	
5#	17232891000	GROMET, AIR CLEANER	1	
6	17235Z4M830	NOSE, SILENCER	1	
7%	17238ZE7010	COLLAR, AIR CLEANER	2	
8%	17239ZE1000	COLLAR (B), AIR CLEANER	1	
9	17410Z4M000	ELBOW CP, AIR CLEANER.....	1.....	INCLUDES ITEMS W/%
10	90325044000	NUT, TOOL BOX SETTING	1	
11	9405006000	FLANGE NUT 6MM	2	
12	957010602000	FLANGE BOLT 6X20	1	
13	90300Z1V000	NUT, AIR CLEANER	1	

HONDA GX160UT2QMXC ENGINE — AIR CLEANER ASSY.

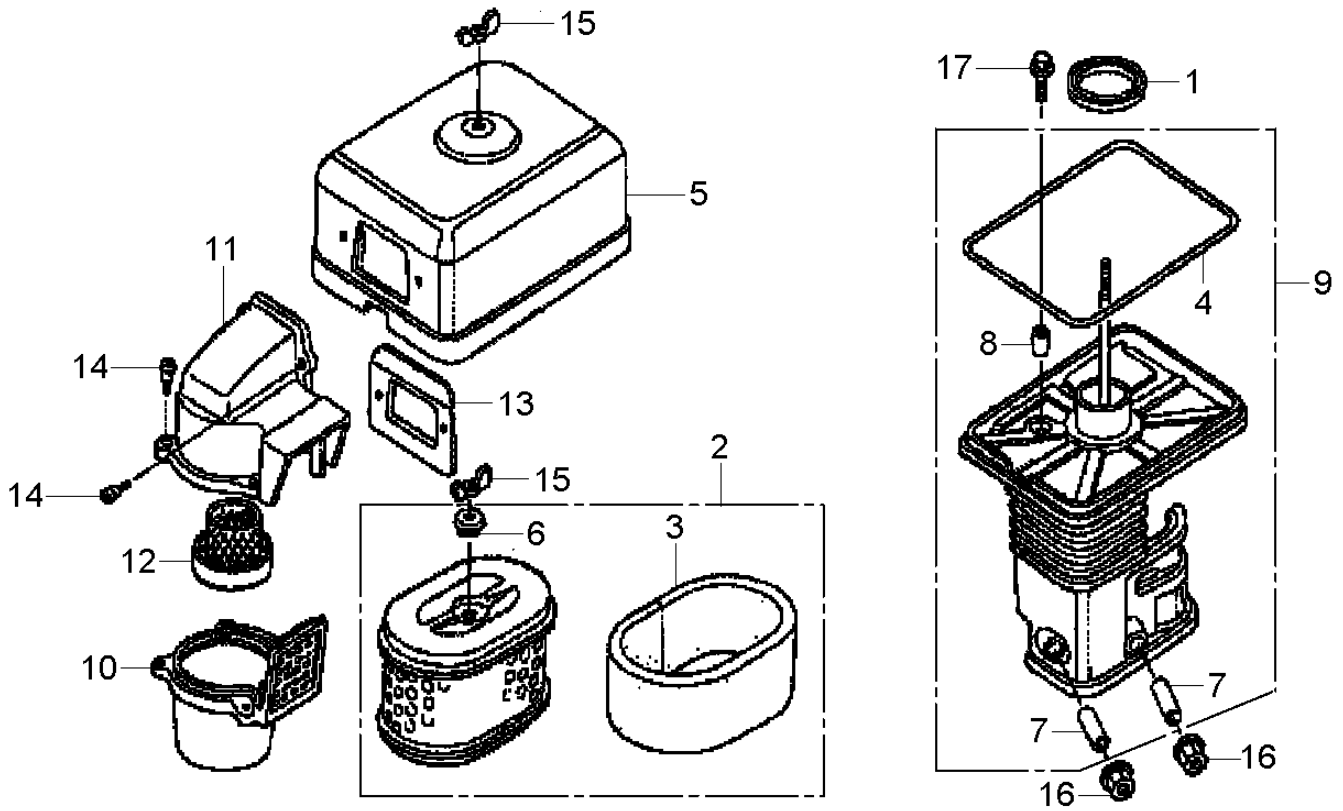

HONDA GX160UT2QMXC ENGINE — AIR CLEANER ASSY.

<u>NO.</u>	<u>PART NO.</u>	<u>PART NAME</u>	<u>QTY.</u>	<u>REMARKS</u>
1	16271ZE1000	PACKING, ELBOW	1	
1	16271ZE1000	PACKING, ELBOW	1	
2	17210ZE1822	ELEMENT, AIR CLEANER	1	
3	17218ZE1821	FILTER, OUTER	1	
4	17219733010	PACKING, AIR CLEANER COVER	1	
5	17230ZE1841	COVER, AIR CLEANER	1	
6	17232891000	GROMMET, AIR CLEANER	1	
7	17238ZE7010	COLLAR, AIR CLEANER	2	
8	17239733000	COLLAR B, AIR CLEANER	1	
9	17410ZE1841	ELBOW COMP., AIR CLEANER	1	
10	17470ZE1842	CASE, PRE AIR CLEANER	1	
11	17475ZE1841	CAP, PRE AIR CLEANER	1	
12	17476ZE1841	GUIDE, PRE AIR CLEANER	1	
13	17478ZE1841	PLATE, PRE AIR CLEANER	1	
14	90300GB0900	BOLT, MUDGUARD	1	
15	90325044000	NUT, TOOL BOX SETTING	1	
16	9405006000	NUT, FLANGE, 6MM	2	
17	957010602000	BOLT, FLANGE, 6X20	1	

HONDA GX160UT2QMX2/QMXC ENGINE — MUFFLER ASSY.

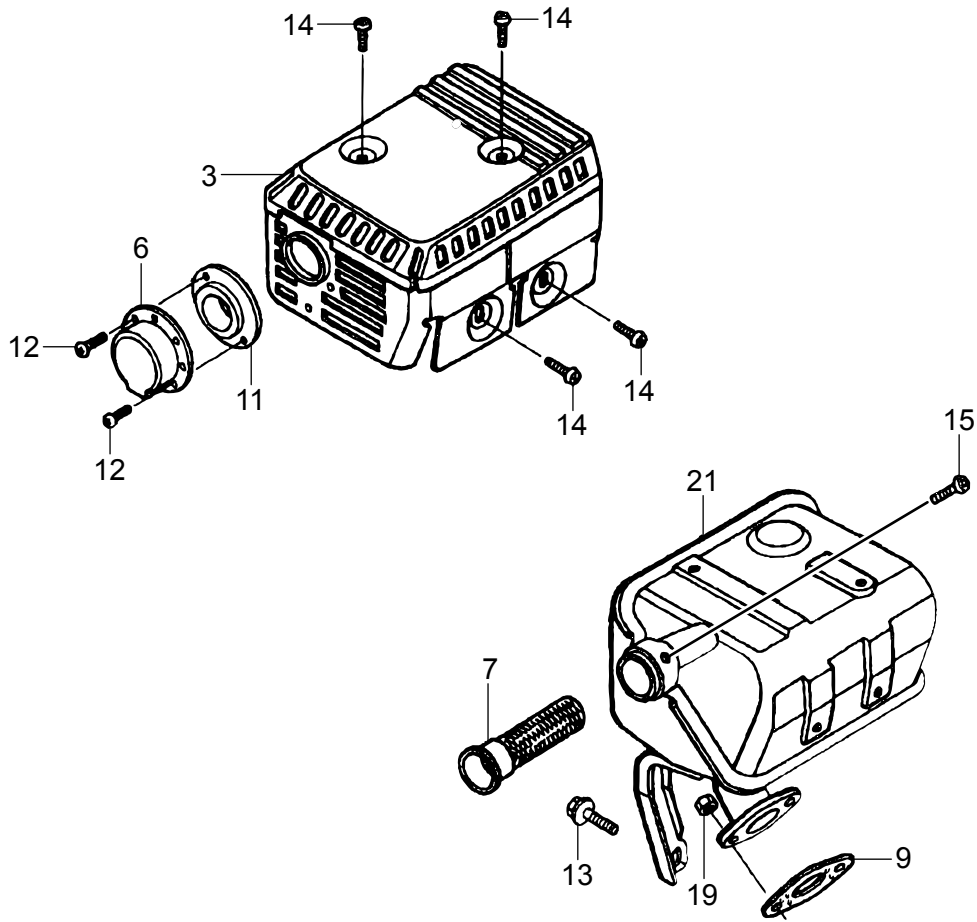

HONDA GX160UT2QMX2/QMXC ENGINE — MUFFLER ASSY.

<u>NO.</u>	<u>PART NO.</u>	<u>PART NAME</u>	<u>QTY.</u>	<u>REMARKS</u>
3	18320Z4M800	PROTECTOR CP, MUFFLER (STD)	1	
3◇	18320Z4M811	PROTECTOR CP, MUFFLER (STD)	1	
6	18340ZE1010	DEFLECTOR CP	1	
7	18355ZE1000	ARRESTER, SPARK	1	
9	18381Z0T801	GASKET, MUFFLER	1	
11	18522ZE1000	GUIDE, MUFFLER	1	
12	90002Z0T800	SCREW, TAPPING, 4X8	2	
13	90016ZE1000	FLANGE BOLT 6X13	1	
14	90050ZE1000	TAPPING SCREW 5X8	4	
15	90055ZE1000	TAPPING SCREW 4X6	1	
19	94001080000S	NUT 8MM	2	
21	18310Z4M810	MUFFLER COMPLETE	1	
21◇	18310Z4MV51	MUFFLER COMPLETE	1	

NOTICE

GX160UT2QMX2

◇ GX160UT2QMXC

HONDA GX160UT2QMX2/QMXC ENGINE — FUEL TANK ASSY.

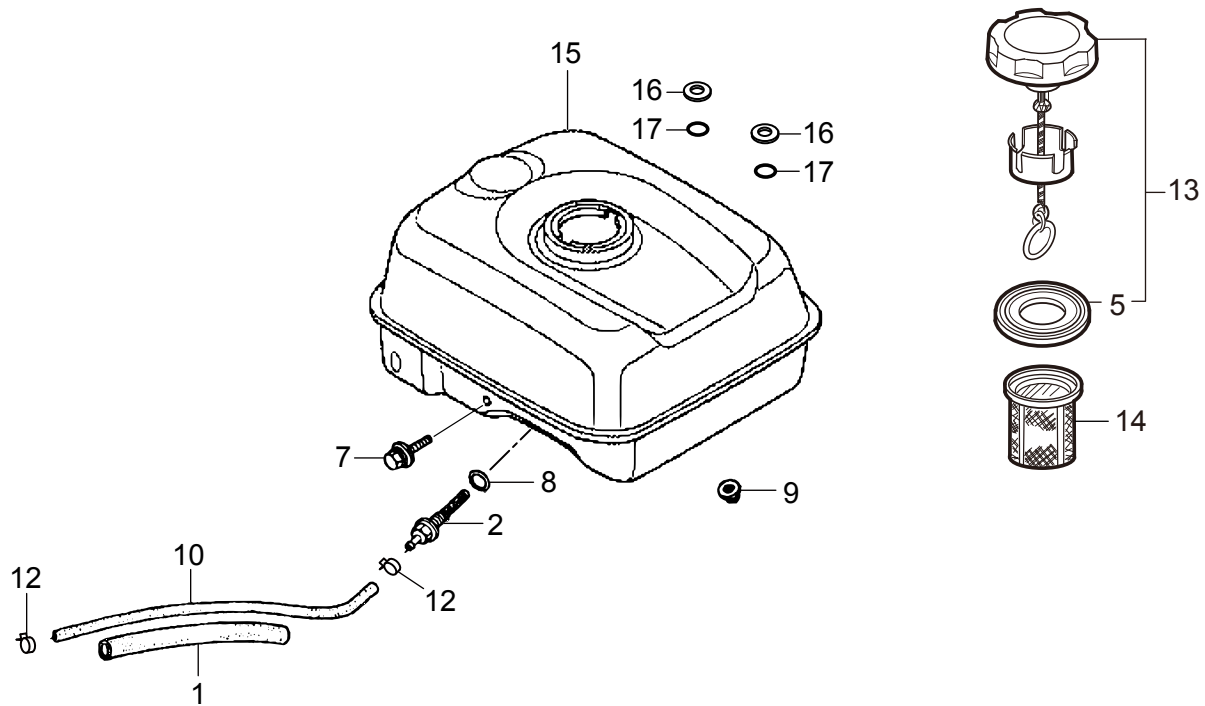

HONDA GX160UT2QMX2/QMXC ENGINE — FUEL TANK ASSY.

NO.	PART NO.	PART NAME	QTY.	REMARKS
1	16854ZH8000	RUBBER, SUPPORT (107MM)	1	
2	16955ZE1010	JOINT, FUEL TANK	1	
5%	17631Z0T801	PACKING, FUEL FILLER CAP	1	
7	90004ZH7003	FLANGE BOLT 6X29	1	
8	91353671004	O-RING 14MM	1	
9	9405006000	FLANGE NUT 6MM	2	
10	91424Z4M003	TUBE, FUEL 4.5X145	1	
12	950024080008	CLAMP, TUBE (D8)	2	
13	17620Z4H020	CAP COMP. , FUEL FILLER	1.....	INCLUDES ITEM W/%
13◇	17620Z4H900	CAP COMP. , FUEL FILLER	1.....	INCLUDES ITEM W/%
14	17672Z4H000	FILTER, FUEL	1	
15	17510Z4M000ZB	TANK COMPLETE, FUEL NH1, BLK	1	
16	90503898000	WASHER, TANK CUSHION	2	
17	91302Z4M003	O-RING 5.5X1.5	2	

NOTICE

GX160UT2QMX2

◇ GX160UT2QMXC

HONDA GX160UT2QMX2/QMXC ENGINE — FLYWHEEL ASSY.

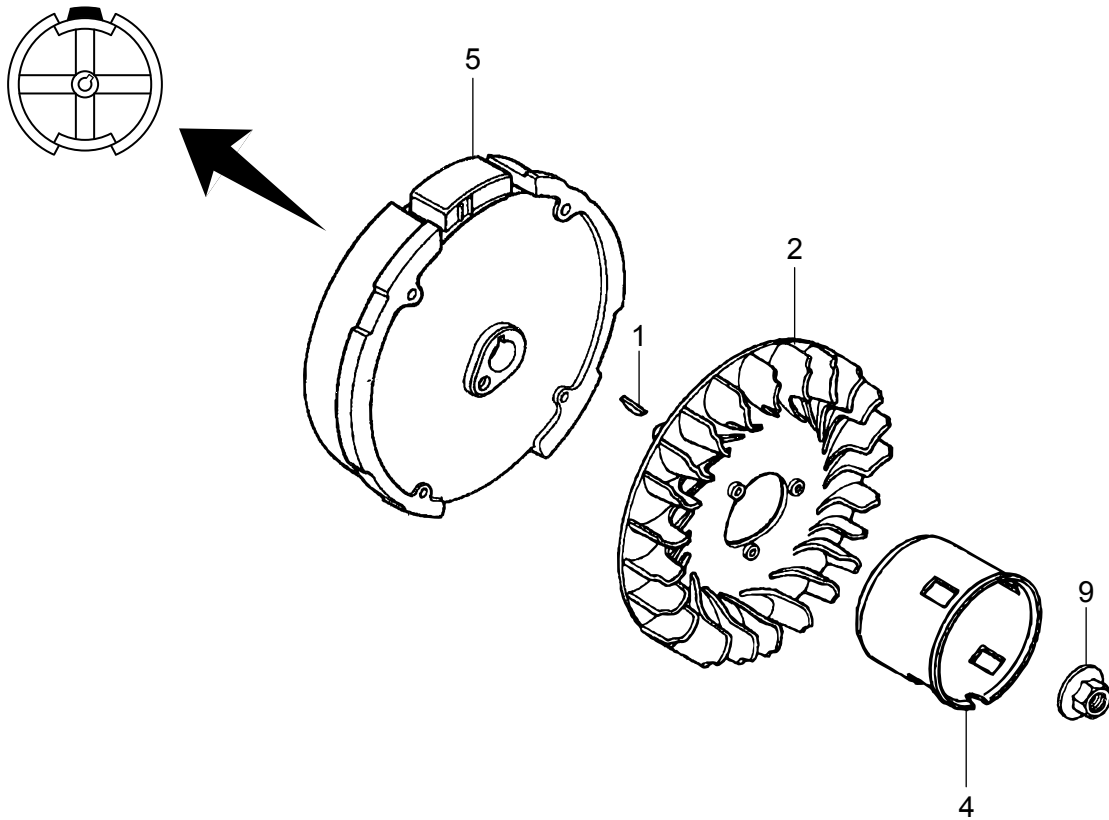

HONDA GX160UT2QMX2/QMXC ENGINE — FLYWHEEL ASSY.

<u>NO.</u>	<u>PART NO.</u>	<u>PART NAME</u>	<u>QTY.</u>	<u>REMARKS</u>
1	13331357000	WOODRUFF KEY 25X18	1	
2	19511ZE1000	COOLING FAN	1	
4	28451ZH8801	STARTER PULLEY	1	
5	31110Z4M000	FLYWHEEL COMPLETE	1	
9	90201Z0T800	NUT, SPECIAL 14MM	1	

HONDA GX160UT2QMX2/QMXC ENGINE — IGN. COIL ASSY.

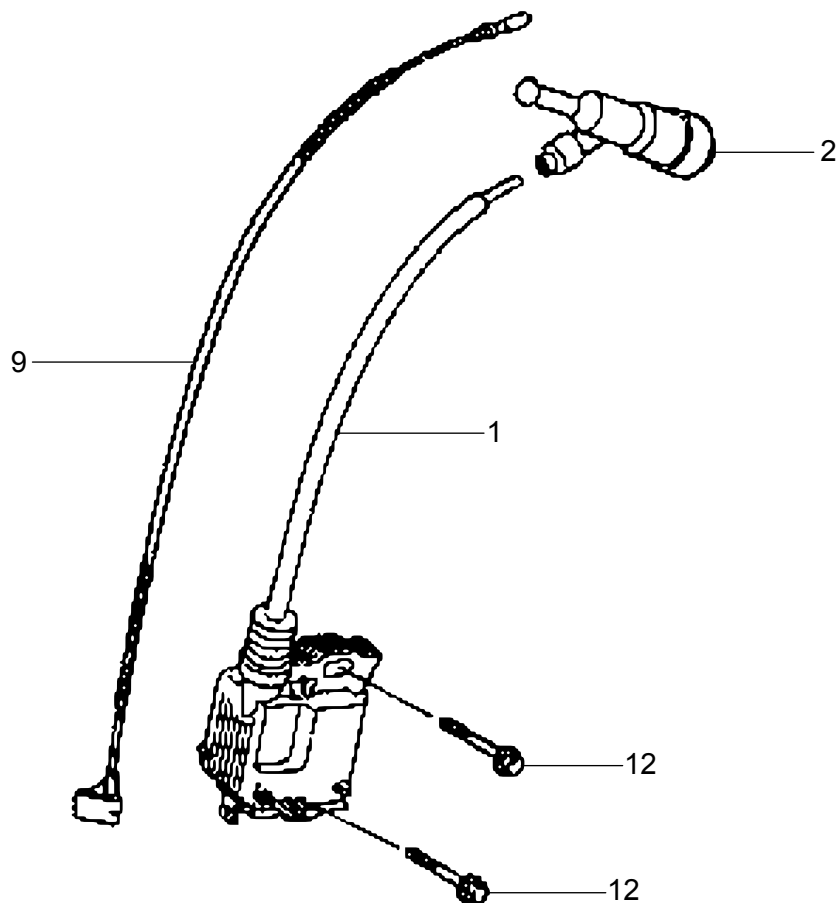

HONDA GX160UT2QMX2/QMXC ENGINE — IGN. COIL ASSY.

<u>NO.</u>	<u>PART NO.</u>	<u>PART NAME</u>	<u>QTY.</u>	<u>REMARKS</u>
1	30500Z0T802	COIL ASSY, IGNITION	1	
2	30700Z0T811	CAP ASSY, NOISE SUPPRESSOR	1	
2◇	30700Z0T812	CAP ASSY, NOISE SUPPRESSOR	1	
9	36101ZE1010	CORD, STOP SWITCH 370MM	1	
12	90121952000	FLANGE BOLT 6X25	2	

NOTICE

GX160UT2QMX2

◇ GX160UT2QMXC

HONDA GX160UT2QMX2/QMXC ENGINE — CONTROL ASSY.

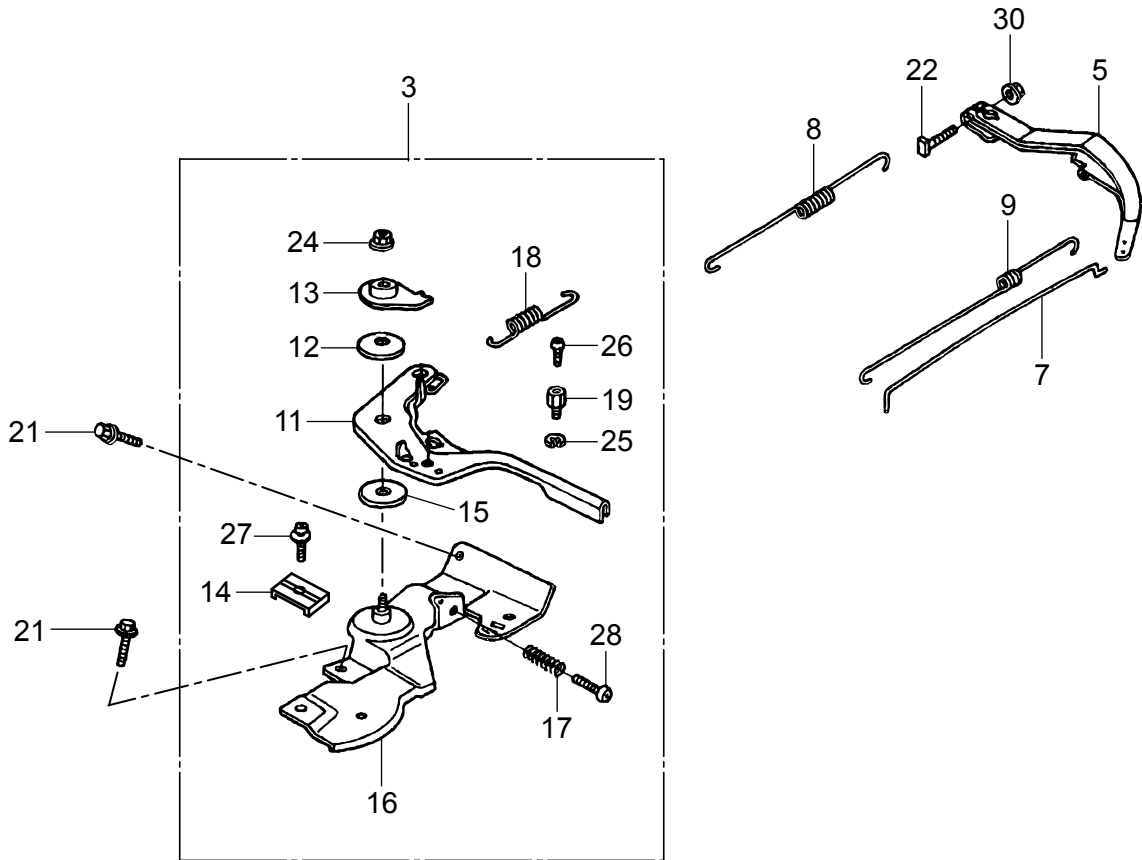

HONDA GX160UT2QMX2/QMXC ENGINE — CONTROL ASSY.

NO.	PART NO.	PART NAME	QTY.	REMARKS
3	16500Z4M306	CONTROL ASSY.....	1	INCLUDES ITEMS W/#
5	16551Z4M000	ARM, GOVERNOR	1	
7	16555Z4M000	ROD, GOVERNOR	1	
8	16561Z4M010	SPRING GOVERNOR	1	
9	16562Z4M000	SPRING, THROTTLE RETURN	1	
11#	16571Z4M000	LEVER, CONTROL	1	
12#	16574ZE1000	LEVER SPRING	1	
13#	16575ZH8000	WASHER, CONTROL LEVER	1	
14#	16576891000	HOLDER, CABLE	1	
15#	16578ZE1000	SPACER, CONTROL LEVER	1	
16#	16580Z4M810	BASE CP, CONTROL	1	
16#◇	16580Z4M850	BASE CP, CONTROL	1	
17#	16584883300	ADJUSTING SPRING	1	
18#	16592ZE1810	SPRING, CABLE, RETURN	1	
19#	16594883010	HOLDER, WIRE	1	
21	90013883000	FLANGE BOLT 6X12	2	
22#	90015ZE5010	BOLT, GOVERNOR ARM	1	
22#◇	90015Z5T000	BOLT, GOVERNOR ARM	1	
24#	90114SA0000	LOCK NUT 6MM	1	
25#	90605230000	CIR CLIP	1	
26#	93500040060H	SCREW 4X6	1	
27#	93500050160A	SCREW 5X16	1	
28#	93500050250H	SCREW 5X25	1	
30	9405006000	FLANGE NUT 6MM	1	

NOTICE

GX160UT2QMX2

◇ GX160UT2QMXC

HONDA GX160UT2QMX2/QMXC ENGINE — DECALS ASSY.

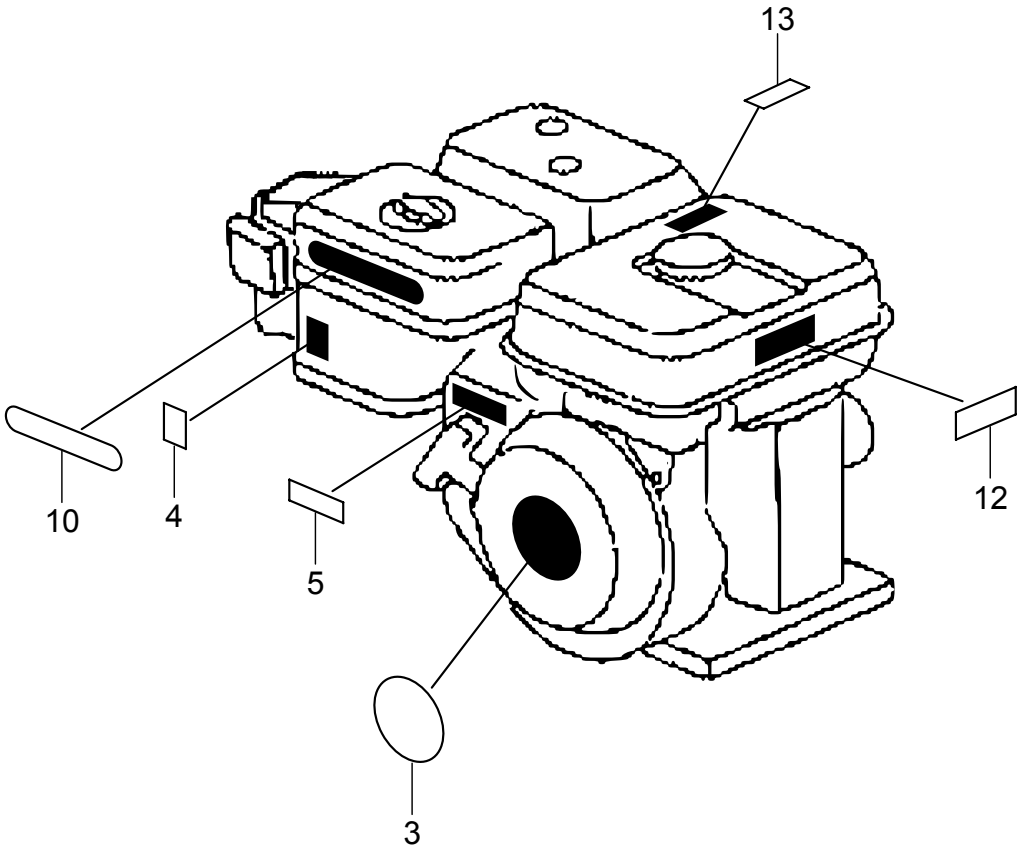

HONDA GX160UT2QMX2/QMXC ENGINE — DECALS ASSY.

<u>NO.</u>	<u>PART NO.</u>	<u>PART NAME</u>	<u>QTY.</u>	<u>REMARKS</u>
3	87521Z4M000	EMBLEM (GX160)	1	
4	87528Z4M000	MARK, CHOKE	1	
5	87532ZH7000	MARK, THROTTLE INDICATION	1	
10◇	87535ZE1841	MARK, AIR CLEANER, GX160UT2QMXC		
12	87516Z4H010	MARK, OP CAUTION	1	
13	87539Z4M000	MARK, EX. CAUTION	1	

TERMS AND CONDITIONS OF SALE — PARTS

PAYMENT TERMS

Terms of payment for parts are net 30 days.

FREIGHT POLICY

All parts orders will be shipped collect or prepaid with the charges added to the invoice. All shipments are F.O.B. point of origin. Multiquip's responsibility ceases when a signed manifest has been obtained from the carrier, and any claim for shortage or damage must be settled between the consignee and the carrier.

MINIMUM ORDER

The minimum charge for orders from Multiquip is \$15.00 net. Customers will be asked for instructions regarding handling of orders not meeting this requirement.

RETURNED GOODS POLICY

Return shipments will be accepted and credit will be allowed, subject to the following provisions:

1. A Returned Material Authorization must be approved by Multiquip prior to shipment.
2. To obtain a Return Material Authorization, a list must be provided to Multiquip Parts Sales that defines item numbers, quantities, and descriptions of the items to be returned.
 - a. The parts numbers and descriptions must match the current parts price list.
 - b. The list must be typed or computer generated.
 - c. The list must state the reason(s) for the return.
 - d. The list must reference the sales order(s) or invoice(s) under which the items were originally purchased.
 - e. The list must include the name and phone number of the person requesting the RMA.
3. A copy of the Return Material Authorization must accompany the return shipment.
4. Freight is at the sender's expense. All parts must be returned freight prepaid to Multiquip's designated receiving point.

5. Parts must be in new and resalable condition, in the original Multiquip package (if any), and with Multiquip part numbers clearly marked.
6. The following items are not returnable:
 - a. Obsolete parts. (If an item is in the price book and shows as being replaced by another item, it is obsolete.)
 - b. Any parts with a limited shelf life (such as gaskets, seals, "O" rings, and other rubber parts) that were purchased more than six months prior to the return date.
 - c. Any line item with an extended dealer net price of less than \$5.00.
 - d. Special order items.
 - e. Electrical components.
 - f. Paint, chemicals, and lubricants.
 - g. Decals and paper products.
 - h. Items purchased in kits.
7. The sender will be notified of any material received that is not acceptable.
8. Such material will be held for five working days from notification, pending instructions. If a reply is not received within five days, the material will be returned to the sender at his expense.
9. Credit on returned parts will be issued at dealer net price at time of the original purchase, less a 15% restocking charge.
10. In cases where an item is accepted, for which the original purchase document can not be determined, the price will be based on the list price that was effective twelve months prior to the RMA date.
11. Credit issued will be applied to future purchases only.

PRICING AND REBATES

Prices are subject to change without prior notice. Price changes are effective on a specific date and all orders received on or after that date will be billed at the revised price. Rebates for price declines and added charges for price increases will not be made for stock on hand at the time of any price change.

Multiquip reserves the right to quote and sell direct to Government agencies, and to Original Equipment Manufacturer accounts who use our products as integral parts of their own products.

SPECIAL EXPEDITING SERVICE

A \$35.00 surcharge will be added to the invoice for special handling including bus shipments, insured parcel post or in cases where Multiquip must personally deliver the parts to the carrier.

LIMITATIONS OF SELLER'S LIABILITY

Multiquip shall not be liable hereunder for damages in excess of the purchase price of the item with respect to which damages are claimed, and in no event shall Multiquip be liable for loss of profit or good will or for any other special, consequential or incidental damages.

LIMITATION OF WARRANTIES

No warranties, express or implied, are made in connection with the sale of parts or trade accessories nor as to any engine not manufactured by Multiquip. Such warranties made in connection with the sale of new, complete units are made exclusively by a statement of warranty packaged with such units, and Multiquip neither assumes nor authorizes any person to assume for it any other obligation or liability whatever in connection with the sale of its products. Apart from such written statement of warranty, there are no warranties, express, implied or statutory, which extend beyond the description of the products on the face hereof.

Effective: February 22, 2006

OPERATION AND PARTS MANUAL

HERE'S HOW TO GET HELP

PLEASE HAVE THE MODEL AND SERIAL
NUMBER ON-HAND WHEN CALLING

UNITED STATES

Multiquip Corporate Office

18910 Wilmington Ave.
Carson, CA 90746
Contact: mq@multiquip.com

Tel. (800) 421-1244
Fax (310) 537-3927

Service Department

800-421-1244
310-537-3700

Technical Assistance

800-478-1244

Fax: 310-943-2238

MQ Parts Department

800-427-1244
310-537-3700

Fax: 800-672-7877

Warranty Department

800-421-1244
310-537-3700

Fax: 310-943-2249

CANADA

Multiquip

4110 Industriel Boul.
Laval, Quebec, Canada H7L 6V3
Contact: infocanda@multiquip.com

Tel: (450) 625-2244
Tel: (877) 963-4411
Fax: (450) 625-8664

UNITED KINGDOM

Multiquip (UK) Limited Head Office

Unit 2, Northpoint Industrial Estate,
Globe Lane,
Dukinfield, Cheshire SK16 4UJ
Contact: sales@multiquip.co.uk

Tel: 0161 339 2223
Fax: 0161 339 3226

© COPYRIGHT 2016, MULTIQUIP INC.

Multiquip Inc, the MQ logo and the Mikasa logo are registered trademarks of Multiquip Inc. and may not be used, reproduced, or altered without written permission. All other trademarks are the property of their respective owners and used with permission.

This manual MUST accompany the equipment at all times. This manual is considered a permanent part of the equipment and should remain with the unit if resold.

The information and specifications included in this publication were in effect at the time of approval for printing. Illustrations, descriptions, references and technical data contained in this manual are for guidance only and may not be considered as binding. Multiquip Inc. reserves the right to discontinue or change specifications, design or the information published in this publication at any time without notice and without incurring any obligations.

Your Local Dealer is:

