

OPERATION AND PARTS MANUAL



MODEL JH90C WALK-BEHIND TROWEL (HONDA GX270UT2QA2 GASOLINE ENGINE)

Revision #2 (9/4/15)

Original Version

To find the latest revision of this
publication, visit our website at:
www.multiquip.com



THIS MANUAL MUST ACCOMPANY THE EQUIPMENT AT ALL TIMES.

P/N 30221

FUEL AND CHEMICAL EXPOSURE WARNINGS



WARNING

Gasoline engine exhaust and some of its constituents, and some dust created by power sanding, sawing, grinding, drilling and other construction activities contains chemicals known to the State of California to cause cancer, birth defects and other reproductive harm. Some examples of these chemicals are:

- Lead from lead-based paints.
- Crystalline silica from bricks.
- Cement and other masonry products.
- Arsenic and chromium from chemically treated lumber.

Your risk from these exposures varies, depending on how often you do this type of work. To reduce your exposure to these chemicals: **ALWAYS** work in a well ventilated area, and work with approved safety equipment, such as dust masks that are specially designed to filter out microscopic particles.

SILICOSIS/RESPIRATORY WARNINGS

⚠️ WARNING



SILICOSIS WARNING

Grinding/cutting/drilling of masonry, concrete, metal and other materials with silica in their composition may give off dust or mists containing crystalline silica. Silica is a basic component of sand, quartz, brick clay, granite and numerous other minerals and rocks. Repeated and/or substantial inhalation of airborne crystalline silica can cause serious or fatal respiratory diseases, including silicosis. In addition, California and some other authorities have listed respirable crystalline silica as a substance known to cause cancer. When cutting such materials, always follow the respiratory precautions mentioned above.

⚠️ WARNING

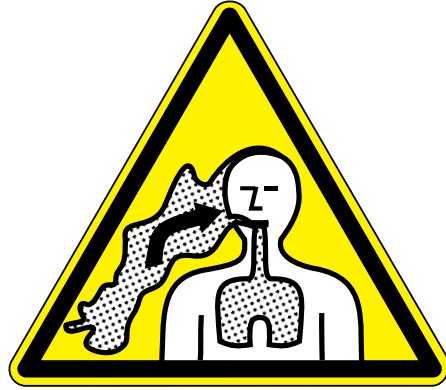

RESPIRATORY HAZARDS

Grinding/cutting/drilling of masonry, concrete, metal and other materials can generate dust, mists and fumes containing chemicals known to cause serious or fatal injury or illness, such as respiratory disease, cancer, birth defects or other reproductive harm. If you are unfamiliar with the risks associated with the particular process and/or material being cut or the composition of the tool being used, review the material safety data sheet and/or consult your employer, the material manufacturer/supplier, governmental agencies such as OSHA and NIOSH and other sources on hazardous materials. California and some other authorities, for instance, have published lists of substances known to cause cancer, reproductive toxicity, or other harmful effects.

Control dust, mist and fumes at the source where possible. In this regard use good work practices and follow the recommendations of the manufacturers or suppliers, OSHA/NIOSH, and occupational and trade associations. Water should be used for dust suppression when wet cutting is feasible. When the hazards from inhalation of dust, mists and fumes cannot be eliminated, the operator and any bystanders should always wear a respirator approved by NIOSH/MSHA for the materials being used.

TABLE OF CONTENTS

JH90C WALK-BEHIND TROWEL

Fuel And Chemical Exposure Warnings	2
Silicosis/Respiratory Warnings	3
Table Of Contents	4
Parts Ordering Procedures	5
Training Checklist	6
Daily Pre-Operation Checklist	7
Safety Information	8-12
Trowel Specifications/Dimensions	13
Engine Specifications	14
General Information	15
Trowel Components	16-17
Engine Components	18
Assembly And Installation	19-23
Inspection	23-24
Operation	25-29
Options	30-31
Maintenance	32-40
Troubleshooting	41-44
Wiring Diagram	45
Explanation Of Code In Remarks Column	46
Suggested Spare Parts	47

Component Drawings

Nameplates And Decals	48-49
Standard Handle Assembly	50-51
Standard Handle Assembly	52-53
Quick Pitch Handle Assembly	54-55
Quick Pitch Handle Assembly	56-57
Guard Ring And Engine Mounting Assembly ...	58-59
Gearbox Assembly	60-61
Engine And Clutch Assembly	62-63
Spider Assembly	64-65
Blades And Pan Assembly	66-67

Honda GX270UT2QA2 Gasoline Engine

Recoil Starter Assembly	68-69
Fan Cover Assembly	70-71
Carburetor Assembly	72-73
Air Cleaner Assembly	74-75
Muffler Assembly	76-77
Fuel Tank Assembly	78-79
Flywheel Assembly	80-81
Cylinder Head Assembly	82-83
Ignition Coil Assembly	84-85
Control Assembly	86-87
Cylinder Barrel Assembly	88-89
Crankcase Cover Assembly	90-91
Crankshaft Assembly	92-93
Piston Assembly	94-95
Camshaft Assembly	96-97
Label Assembly	98-99
Terms And Conditions Of Sale — Parts	100

NOTICE

Specifications and part numbers are subject to change without notice.

PARTS ORDERING PROCEDURES

Ordering parts has never been easier! Choose from three easy options:

Effective:
January 1st, 2006

www.multiquip.com



Order via Internet (Dealers Only):

Order parts on-line using Multiquip's SmartEquip website!

- View Parts Diagrams
- Order Parts
- Print Specification Information



If you have an MQ Account, to obtain a Username and Password, E-mail us at: parts@multiquip.com.

To obtain an MQ Account, contact your District Sales Manager for more information.

Goto www.multiquip.com and click on

Order Parts to log in and save!

Use the **internet** and qualify for a **5% Discount** on *Standard orders* for all orders which include complete part numbers.*

Note: Discounts Are Subject To Change

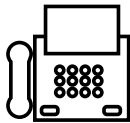

Order via Fax (Dealers Only):

All customers are welcome to order parts via Fax.

Domestic (US) Customers dial:
1-800-6-PARTS-7 (800-672-7877)

Fax your order in and qualify for a **2% Discount** on *Standard orders* for all orders which include complete part numbers.*

Note: Discounts Are Subject To Change



Order via Phone: Domestic (US) Dealers Call:
1-800-427-1244

Non-Dealer Customers:

Contact your local Multiquip Dealer for parts or call 800-427-1244 for help in locating a dealer near you.



International Customers should contact their local Multiquip Representatives for Parts Ordering information.

When ordering parts, please supply:

- | | |
|---|--|
| <input type="checkbox"/> Dealer Account Number | <input type="checkbox"/> Specify Preferred Method of Shipment: |
| <input type="checkbox"/> Dealer Name and Address | <input checked="" type="checkbox"/> UPS/Fed Ex <input checked="" type="checkbox"/> DHL |
| <input type="checkbox"/> Shipping Address (if different than billing address) | <input type="checkbox"/> Priority One <input checked="" type="checkbox"/> Truck |
| <input type="checkbox"/> Return Fax Number | <input type="checkbox"/> Ground |
| <input type="checkbox"/> Applicable Model Number | <input type="checkbox"/> Next Day |
| <input type="checkbox"/> Quantity, Part Number and Description of Each Part | <input type="checkbox"/> Second/Third Day |

NOTICE

All orders are treated as *Standard Orders* and will ship the same day if received prior to 3PM PST.

WE ACCEPT ALL MAJOR CREDIT CARDS!



TRAINING CHECKLIST

Training Checklist			
No.	Description	OK?	Date
1	Read operation manual completely.		
2	Machine layout, location of components, checking of engine oil level.		
3	Fuel system, refueling procedure.		
4	Operation of controls (machine not running).		
5	Safety controls, safety stop switch operation.		
6	Emergency stop procedures.		
7	Startup of machine, engine choke.		
8	Maintaining a hover.		
9	Maneuvering.		
10	Pitching.		
11	Concrete finishing techniques.		
12	Shutdown of machine.		
13	Lifting of machine (lifting bale).		
14	Machine transport and storage.		

DAILY PRE-OPERATION CHECKLIST

Daily Pre-Operation Checklist		✓	✓	✓	✓	✓	✓
1	Engine oil level						
2	Gearbox oil level						
3	Condition of blades						
4	Blade pitch operation						
5	Safety stop switch operation						

SAFETY INFORMATION

Do not operate or service the equipment before reading the entire manual. Safety precautions should be followed at all times when operating this equipment. Failure to read and understand the safety messages and operating instructions could result in injury to yourself and others.



SAFETY MESSAGES

The four safety messages shown below will inform you about potential hazards that could injure you or others. The safety messages specifically address the level of exposure to the operator and are preceded by one of four words: **DANGER**, **WARNING**, **CAUTION** or **NOTICE**.

SAFETY SYMBOLS

DANGER

Indicates a hazardous situation which, if not avoided, **WILL** result in **DEATH** or **SERIOUS INJURY**.

WARNING

Indicates a hazardous situation which, if not avoided, **COULD** result in **DEATH** or **SERIOUS INJURY**.

CAUTION

Indicates a hazardous situation which, if not avoided, **COULD** result in **MINOR** or **MODERATE INJURY**.

NOTICE

Addresses practices not related to personal injury.

Potential hazard associated with the operation of this equipment will be referenced with **hazard symbols** which may appear throughout this manual in conjunction with safety messages.

SYMBOL	SAFETY HAZARD
	<p>WARNING Lethal Exhaust Gas Hazard</p> <ul style="list-style-type: none"> Inhaling exhaust fumes can result in severe injury or death. Only operate equipment in well ventilated areas. DO NOT inhale exhaust gases/fumes.
	<p>WARNING Explosive Fuel Hazard</p> <ul style="list-style-type: none"> Gasoline fuel can cause fire or explosion. Stop engine before refueling. Keep cigarettes, sparks and flames away from hot surfaces.
	<p>CAUTION Burn Hazard</p> <ul style="list-style-type: none"> HOT PARTS can burn skin. DO NOT touch hot parts. Allow machine a sufficient amount of time to cool before performing maintenance.

Warning decals associated with the operation of this equipment are defined below:

DECAL	SAFETY HAZARD
	<p>WARNING Rotating Blade Hazard</p> <ul style="list-style-type: none"> Keep hands and feet clear of guard rings. Stop engine before servicing.
	<p>WARNING Read Manual</p> <p>To avoid injury you must read and understand operator's manual before using this machine.</p>
	<p>WARNING Lifting Crush Hazard</p> <ul style="list-style-type: none"> NEVER allow any person to stand underneath the trowel while lifting. DO NOT lift trowel with pans attached. ALWAYS make sure handle is securely attached. On Quick Pitch™ models make sure T-Handle latch is locked (engaged).
	<p>ALWAYS wear protective clothing when operating this equipment</p>
	<p>WARNING Training</p> <p>This machine to be operated by qualified personnel. Ask for training as needed.</p>
	<p>WARNING Guard Hazard</p> <p>NEVER operate this equipment with guards removed. Keep hands clear.</p>

SAFETY INFORMATION

GENERAL SAFETY

CAUTION

- **NEVER** operate this equipment without proper protective clothing, shatterproof glasses, respiratory protection, hearing protection, steel-toed boots and other protective devices required by the job or city and state regulations.



- Avoid wearing jewelry or loose fitting clothes that may snag on the controls or moving parts as this can cause serious injury.

- **NEVER** operate this equipment when not feeling well due to fatigue, illness or when under medication.



- **NEVER** operate this equipment under the influence of drugs or alcohol.



- **ALWAYS** clear the work area of any debris, tools, etc. that would constitute a hazard while the equipment is in operation.

- No one other than the operator is to be in the working area when the equipment is in operation.

- **DO NOT** use the equipment for any purpose other than its intended purposes or applications.

NOTICE

- This equipment should only be operated by trained and qualified personnel 18 years of age and older.

- Whenever necessary, replace nameplate, operation and safety decals when they become difficult read.

- Manufacturer does not assume responsibility for any accident due to equipment modifications. Unauthorized equipment modification will void all warranties.

- **NEVER** use accessories or attachments that are not recommended by Multiquip for this equipment. Damage to the equipment and/or injury to user may result.

- **ALWAYS** know the location of the nearest fire extinguisher.



- **ALWAYS** know the location of the nearest first aid kit.



- **ALWAYS** know the location of the nearest phone or **keep a phone on the job site**. Also, know the phone numbers of the nearest **ambulance, doctor** and **fire department**. This information will be invaluable in the case of an emergency.



SAFETY INFORMATION

TROWEL SAFETY

DANGER

- Engine fuel exhaust gases contain poisonous carbon monoxide. This gas is colorless and odorless, and can cause death if inhaled.
- The engine of this equipment requires an adequate free flow of cooling air. **NEVER** operate this equipment in any enclosed or narrow area where free flow of the air is restricted. If the air flow is restricted it will cause injury to people and property and serious damage to the equipment or engine.



- **NEVER** operate the equipment in an explosive atmosphere or near combustible materials. An explosion or fire could result causing severe **bodily harm or even death.**



WARNING

- **ALWAYS** keep clear of rotating or moving parts while operating the trowel.
- **DO NOT** start or operate the trowel if the drive train will not disengage. Centrifugal force between the trowel and surface when starting can cause uncontrolled handle movement that can cause serious injury. The handle must not move while pulling the engine recoil starter.
- **NEVER** disconnect any **emergency or safety devices.** These devices are intended for operator safety. Disconnection of these devices can cause severe injury, bodily harm or even death. Disconnection of any of these devices will void all warranties.



CAUTION

- **NEVER** stand on trowel during operation.
- **NEVER** lubricate components or attempt service on a running machine.
- **NEVER** place your feet or hands inside the guard rings while starting or operating this equipment.

- **ALWAYS** keep work area clear around the trowel. Make sure it is free of debris and objects.

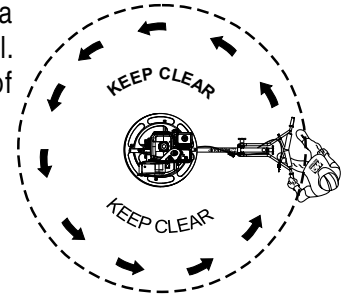

NOTICE

- **ALWAYS** keep the machine in proper running condition.
- Fix damage to machine and replace any broken parts immediately.
- **ALWAYS** store equipment properly when it is not being used. Equipment should be stored in a clean, dry location out of the reach of children and unauthorized personnel.
- A safety manual for operating and maintenance personnel of concrete power trowels produced by the Association of Equipment Manufacturers (AEM) can be obtained for a fee by ordering through their website at www.aem.org.

Order FORM PT-160

ENGINE SAFETY

WARNING

- **DO NOT** place hands or fingers inside engine compartment when engine is running.
- **NEVER** operate the engine with heat shields or guards removed.
- Keep fingers, hands hair and clothing away from all moving parts to prevent injury.
- **DO NOT** remove the engine oil drain plug while the engine is hot. Allow the oil to cool before performing maintenance. This will prevent scalding of personnel.



CAUTION

- **NEVER** touch the hot exhaust manifold, muffler or cylinder. Allow these parts to cool before servicing equipment.



SAFETY INFORMATION

NOTICE

- **NEVER** run engine without an air filter or with a dirty air filter. Severe engine damage may occur. Service air filter frequently to prevent engine malfunction.
- **NEVER** tamper with the factory settings of the engine or engine governor. Damage to the engine or equipment can result if operating in speed ranges above the maximum allowable.



FUEL SAFETY

DANGER

- **DO NOT** add fuel to equipment if it is placed inside truck bed with plastic liner. Possibility exists of explosion or fire due to static electricity.

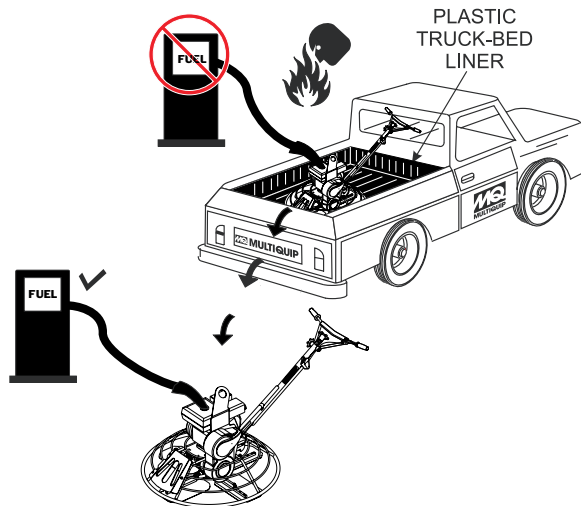

- **DO NOT** start the engine near spilled fuel or combustible fluids. Fuel is extremely flammable and its vapors can cause an explosion if ignited.
- **ALWAYS** refuel in a well-ventilated area, away from sparks and open flames.
- **ALWAYS** use extreme caution when working with **flammable** liquids.
- **DO NOT** fill the fuel tank while the engine is running or hot.
- **DO NOT** overfill tank, since spilled fuel could ignite if it comes into contact with hot engine parts or sparks from the ignition system.

- Store fuel in appropriate containers, in well-ventilated areas and away from sparks and flames.
- **NEVER** use fuel as a cleaning agent.
- **DO NOT** smoke around or near the equipment. Fire or explosion could result from fuel vapors or if fuel is spilled on a hot engine.



TRANSPORTING SAFETY

CAUTION

- **NEVER** allow any person or animal to stand underneath the equipment while lifting.



NOTICE

- Some walk-behind trowels can be lifted or moved by two people utilizing lifting tubes or other special attachments. Generally, however, they must be lifted using lifting bales and cranes, hoists, or forklifts.
- **NEVER** transport trowel with float pans attached unless safety catches are used and are specifically cleared for such transport by the manufacturer.
- **NEVER** hoist the trowel more than three feet off the ground with float pans attached.
- Before lifting, make sure that the lifting bales are not damaged.
- Always make sure crane or lifting device has been properly secured to the lifting bales of the equipment.
- **ALWAYS** shutdown engine before transporting.
- **NEVER** lift the equipment while the engine is running.
- Tighten fuel tank cap securely and close fuel cock to prevent fuel from spilling.
- Use adequate lifting cable (wire or rope) of sufficient strength.
- **DO NOT** lift machine to unnecessary heights.
- **ALWAYS** tie down equipment during transport by securing the equipment with rope.

SAFETY INFORMATION

ENVIRONMENTAL SAFETY/DECOMMISSIONING

NOTICE

Decommissioning is a controlled process used to safely retire a piece of equipment that is no longer serviceable. If the equipment poses an unacceptable and unrepairable safety risk due to wear or damage or is no longer cost effective to maintain (beyond life-cycle reliability) and is to be decommissioned (demolition and dismantlement), be sure to follow rules below.

- **DO NOT** pour waste or oil directly onto the ground, down a drain or into any water source.
- Contact your country's Department of Public Works or recycling agency in your area and arrange for proper disposal of any electrical components, waste or oil associated with this equipment.
- When the life cycle of this equipment is over, remove battery and bring to appropriate facility for lead reclamation. Use safety precautions when handling batteries that contain sulfuric acid.
- When the life cycle of this equipment is over, it is recommended that the trowel frame and all other metal parts be sent to a recycling center.



Metal recycling involves the collection of metal from discarded products and its transformation into raw materials to use in manufacturing a new product.

Recyclers and manufacturers alike promote the process of recycling metal. Using a metal recycling center promotes energy cost savings.

EMISSIONS INFORMATION

NOTICE

The gasoline engine used in this equipment has been designed to reduce harmful levels of carbon monoxide (CO), hydrocarbons (HC) and nitrogen oxides (NOx) contained in gasoline exhaust emissions.

This engine has been certified to meet US EPA Evaporative emissions requirements in the installed configuration.

Attempting to modify or make adjustments to the engine emission system by unauthorized personnel without proper training could damage the equipment or create an unsafe condition.

Additionally, modifying the fuel system may adversely affect evaporative emissions, resulting in fines or other penalties.

Emission Control Label

The emission control label is an integral part of the emission system and is strictly controlled by regulation(s).

The label must remain with the engine for its entire life.

If a replacement emission label is needed, please contact your authorized engine distributor.

TROWEL SPECIFICATIONS/DIMENSIONS

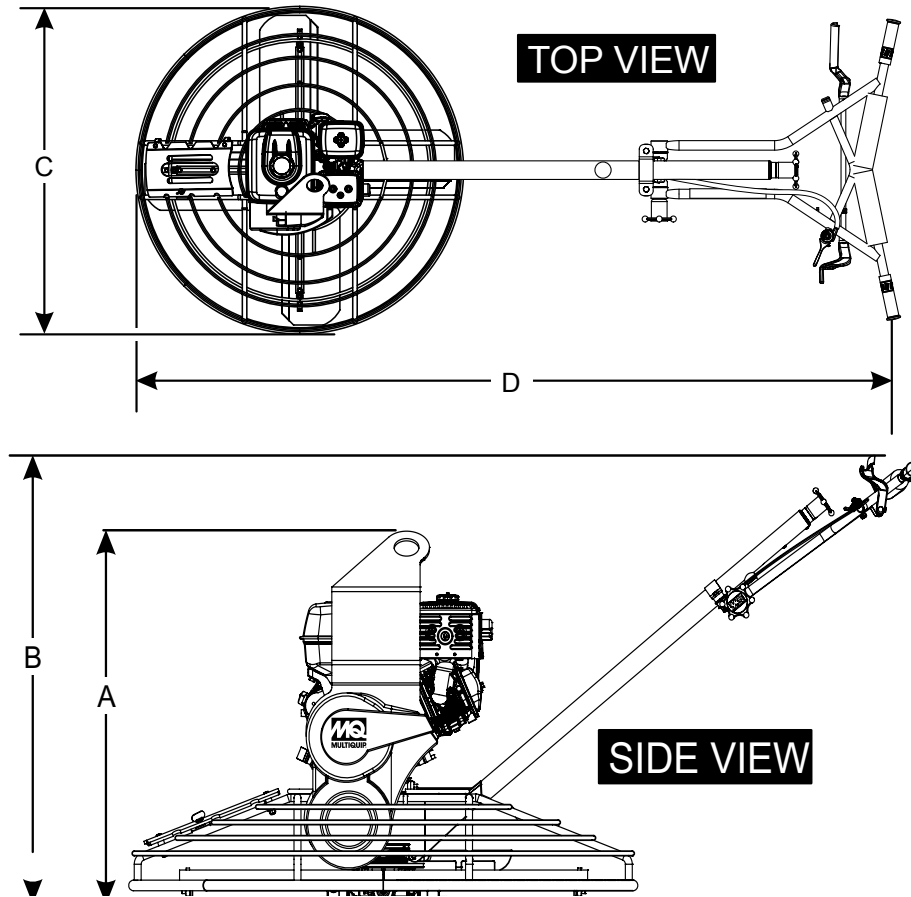

Figure 1. Dimensions

Table 1. Trowel Specifications			
A–Height (Lifting Bale) – in (mm.)	36.7 (931.6)	Path Width – in (mm.)	914 (36)
B–Height (Handle) – in (mm.) Standard	41.4 (1,044.2)	Rotor – RPM (Dry Concrete)	90-155
Quick Pitch™	41.4 (1,044.2)		
C–Width (Ring Diameter) – in (mm.)	36.5 (927.1)	Gear Box Oil Capacity – oz (ml.)	828 (28)
D–Width – in (mm.)	70.5 (1,789.4)	Shipping Weight – lbs. (kg)	Standard
			Quick Pitch™
Number of Blades	4		

ENGINE SPECIFICATIONS

Table 2. JH90C Noise and Vibration Emissions

Model		JH90C
Guaranteed ISO 11201:2010 Based Sound Pressure Level at Operator Station in dB(A)		121
Guaranteed ISO 3744:2010 Based Sound Power Level in dB(A)		90
Hand-Arm Vibration Per ISO 5349-1: 2001 in $m/s^2 \Sigma A(8)$	Standard Handle (SXHC)	1.62
	Quick Pitch™ Handle (QXHC)	1.62

NOTES:

1. Sound Pressure and Power Levels are "A" weighted Measures per ISO 226:2003 (ANSI S1.4-1981). They are measured with the operating condition of the machine which generates the most repeatable but highest values of the sound levels. Under normal circumstances, the sound level will vary depending on the condition of the material being worked upon.
2. The vibration level indicated is the vector sum of the RMS (Root Mean Square) Values of amplitudes on each axis, standardized to an 8 hour exposure period, and obtained using operating condition of the machine that generates the most repeatable but highest values in accordance with the applicable standards for the machine.
3. Per EU Directive 2002/44/EC, the daily exposure action value for whole body vibration is $0.5 m/s^2 \Sigma A(8)$. The daily exposure limit value is $1.15 m/s^2 \Sigma A(8)$.

Table 3. Engine Specifications/Dimensions

Model	Honda GX270UT2QA2 Engine
Type	Air-cooled 4 stroke, Single Cylinder, OHV, Horizontal Shaft Gasoline Engine
Bore X Stroke	3.0 in. X 2.3 in. (77 mm x 58 mm)
Displacement	16.4 cu-in. (270 cc)
Max. Output	8.5 H.P. @ 3600 RPM
Fuel Tank Capacity	Approx. 1.95 U.S. Gallons (6.0 Liters))
Fuel	Unleaded Gasoline
Lube Oil Capacity	1.06 qt. (1.1 liters)
Oil Type	4-Stroke API, SF or SG SAE 10W-30 General Use
Speed Control Method	Centrifugal Flyweight Type
Cooling System	Forced Air
Starting Method	Recoil Start
Spark Plug Type	BPR6ES NGK
Spark Plug Gap	0.028-0.031 in. (0.70 - 0.80 mm)
Dimensions (L x W x H)	15.0 x 16.8 X 16.6 in. (381 X 428 X 422 mm)
Dry Net Weight	55.1 lbs. (25 Kg.)

INTENDED USE

Operate this trowel, tools and components in accordance with the manufacturer's instructions. Use of any other tools for stated operation is considered contrary to designated use. The risk of such use lies entirely with the user. The manufacturer cannot be held liable for damages as a result of misuse.

TROWEL FAMILIARIZATION

This walk-behind trowel is designed for the floating and finishing of concrete slabs.

Take a walk around the trowel. Take notice of all the major components (Figure 2 and Figure 3) like the engine, blades, steering handle, kill switch, gearbox, etc. Check that there is always oil in the engine.

Read all the safety instructions carefully. Safety instructions will be found throughout this manual and on the trowel. Keep all safety information in good, readable condition. Operators should be well trained on the operation and maintenance of the trowel.

Before using your trowel, test it on a flat watered down section of finished concrete that is free of any debris and other objects.

This trial test run will increase your confidence in using the trowel and at the same time it will familiarize you with the trowel's controls. In addition you will understand how the trowel handles under actual conditions.

ENGINE

This trowel is equipped with a HONDA 8.5 HP gasoline engine. Refer to the engine owner's manual for instructions regarding the operation and maintenance of your engine. Please contact your nearest Multiquip Dealer for a replacement should the original manual disappear or otherwise become unusable.

DRIVE SYSTEM

Power is transferred from the engine to the gearbox input shaft via a V-belt pulley drive system. The pulley engages using a centrifugal clutch. See parts section of this manual for a breakdown of the drive system.

GEARBOX

The **gearbox** is located beneath the engine and transfers power to the **spider** assembly. The gearbox controls the rotational speed of the trowel and is equipped with two shafts (input and output).

SPIDER

The vertical output shaft of the gearbox connects to a cast hub called the **spider**. The spider has 4 arms that extend outward that are used for attachment of blades or other accessories. Remember as the gearbox output shaft rotates so does the spider assembly.

GUARD RING

This unit is equipped with a safety guard ring. It is designed to help protect items from coming into contact with the rotating blades while the trowel is in operation.

BLADES

The blades of the trowel finish the concrete as they are rotated around the surface. This trowel comes equipped with four **combination blades** (8 in./203 mm wide) per rotor equally spaced in a radial pattern and attached to a vertical rotating shaft by means of a spider assembly.

TRAINING

For proper training, please use the "TRAINING CHECKLIST" form located in the front of this manual. This checklist will provide an outline for an experienced operator to provide training to a new operator.

TROWEL COMPONENTS

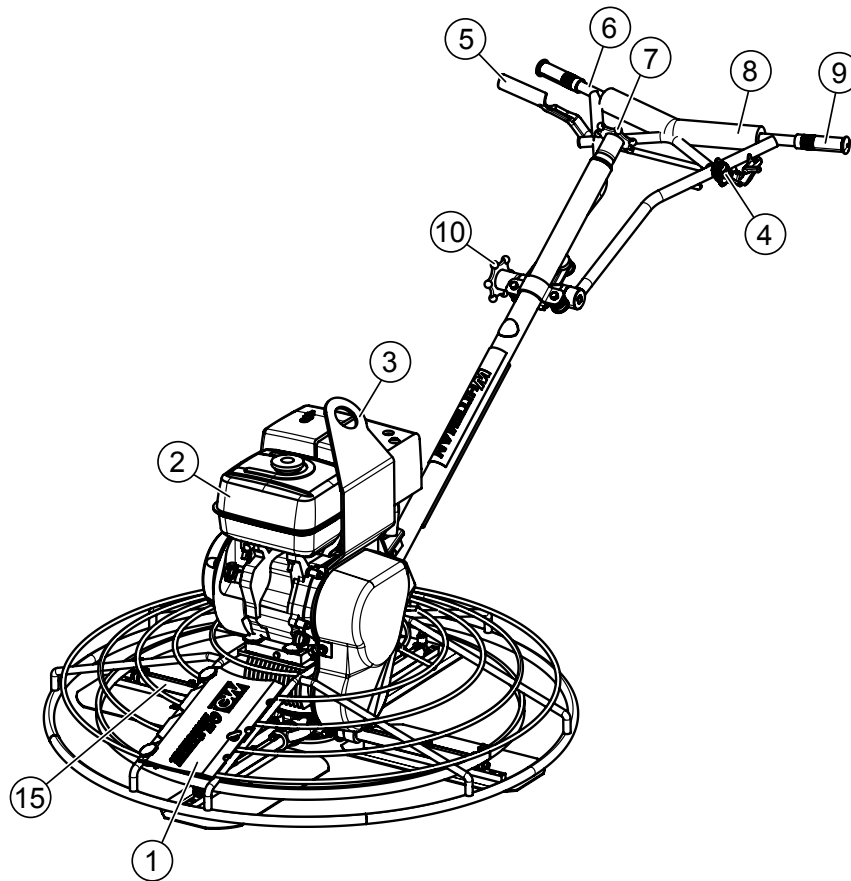

Figure 2. Trowel Control and Components

Figure 2 and Figure 3 shows the location of the basic controls or components, for the trowel. Listed below is a brief explanation of each control or component.

1. **Access Panel** — Allows access to the blade area. **NEVER** run the trowel with this access panel removed.
2. **Engine** — Honda 8.5 HP gasoline engine.
3. **Lifting Bale** — Attach a suitable lifting device to lifting bale whenever lifting of the trowel is required.
4. **Throttle Lever** — Controls engine speed. Returns engine to idle when released.
5. **Left Clutch Lever** — Squeeze to engage clutch. 4-blade rotation will start. This is the primary control lever.
6. **Vibratory Handle Bar** — Installed rubber shock mounts/isolators reduces vibration when the trowel is operating.
7. **Star Wheel Pitch Knob (4-Blade)**— To adjust the pitch of the blades, rotate the star wheel clockwise to pitch blades upwards. Rotate star wheel counterclockwise to pitch blades flat (no pitch).
8. **Handle Bar Pad** — Foam rubber pad that protects the body when coming in contact with handle bar.
9. **Hand Grips** — When maneuvering of the trowel is required **ALWAYS** place both hands on each grip to operate the trowel. Replace hand grips when they become worn or damaged.
10. **Star Wheel Knob (Handlebar Adjuster)** — Changes the angle/height of the handlebar. Loosen the star wheel (turn counterclockwise) to place the handlebar in the desired position. Tighten the star wheel (turn clockwise) to lock handlebar.

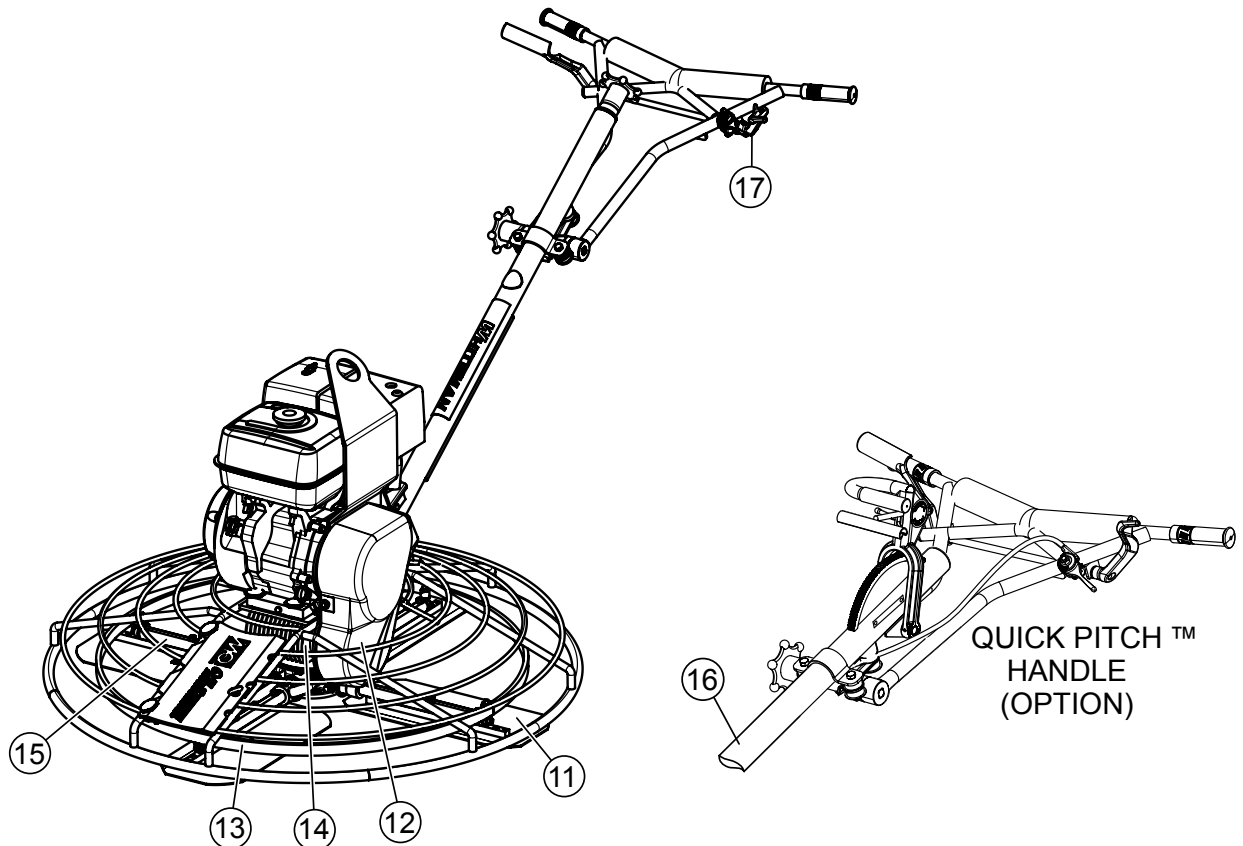
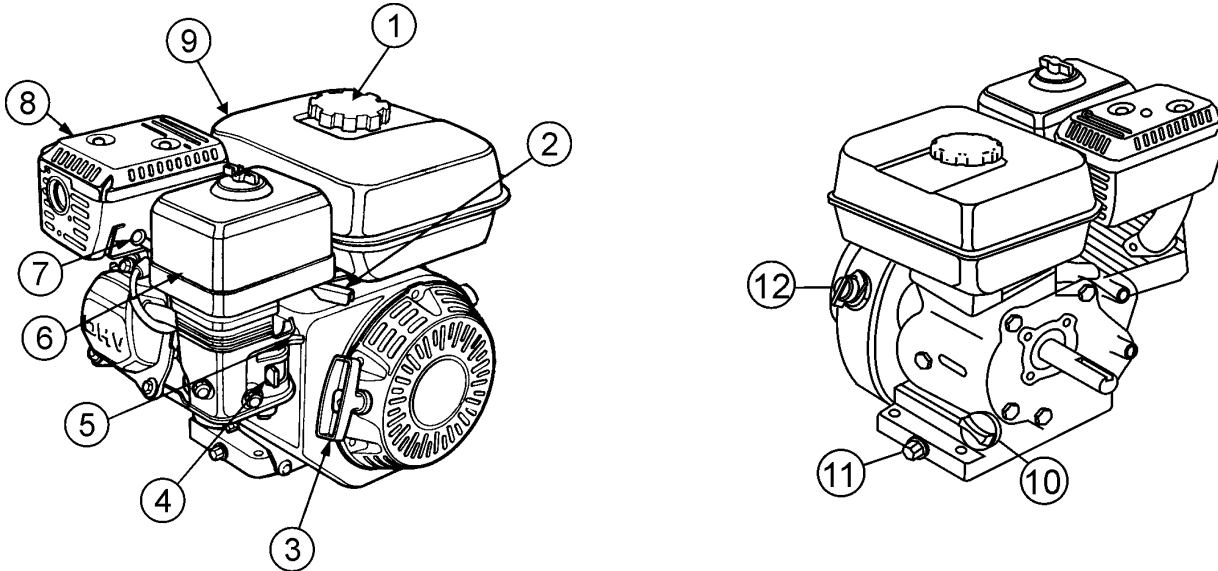

Figure 3. Trowel Control and Components (Cont.)

11. **Blades** — This trowel is equipped with combination blades. These blades are versatile and should take care of most troweling needs. In addition float discs can be attached to the trowel arms that will allow the trowel to float on "wet" concrete.
12. **V-Belt Cover** — Remove this cover to gain access to the V-belt. **NEVER** operate the trowel with this cover removed.
13. **Guard Ring** — **NEVER** put hands or feet inside guard ring while the machine is running.
14. **Gearbox** — Helical worm gear drive gearbox. Provides rotation of blades via engine interface. **ALWAYS** check gearbox oil level (sight glass) prior to each use. Fill with recommended type gearbox oil.
15. **Trowel Arm** — **NEVER** operate the trowel with a bent, broken or out of adjustment trowel arm. If the blades show uneven wear patterns or some blades wear out faster than others, the trowel arm may need to be adjusted. Use the trowel arm adjustment tool P/N 1817 to adjust the trowel arms.
16. **Quick Pitch™ Control Handle** — Contact MQ unit sales for this option.
17. **Right Clutch Lever** — Pull up to engage the clutch. 4-blade rotation will start. This is the secondary control lever.

ENGINE COMPONENTS



INITIAL SERVICING

Figure 4. Engine Controls and Components

The engine (Figure 4) must be checked for proper lubrication and filled with fuel prior to operation. Refer to the manufacturer's engine manual for instructions and details of operation and servicing.

1. **Fuel Filler Cap** – Remove this cap to add unleaded gasoline to the fuel tank. Make sure cap is tightened securely. **DO NOT** over fill.

DANGER



Add fuel to the tank only when the engine is stopped and has had an opportunity to cool down. In the event of a fuel spill, **DO NOT** attempt to start the engine until the fuel residue has been completely wiped up and the area surrounding the engine is dry.

2. **Throttle Lever** – Used to adjust engine RPM speed. This lever is connect to the throttle lever cable located on the handle bars. Reference throttle cable installation procedure in this manual.
3. **Recoil Starter (pull rope)** – Manual-starting method. Pull the starter grip until resistance is felt, then pull briskly and smoothly.
4. **Fuel Valve Lever** – **OPEN** to let fuel flow, **CLOSE** to stop the flow of fuel.
5. **Choke Lever** – Used in the starting of a cold engine, or in cold weather conditions. The choke enriches the fuel mixture.

6. **Air Cleaner** – Prevents dirt and other debris from entering the fuel system. Remove wing-nut on top of air filter canister to gain access to filter element.

NOTICE

Operating the engine without an air filter, with a damaged air filter, or a filter in need of replacement will allow dirt to enter the engine, causing rapid engine wear.

7. **Spark Plug** – Provides spark to the ignition system. Set spark plug gap according to engine manufacturer's instructions. Clean spark plug once a week.
8. **Muffler** – Used to reduce noise and emissions. **NEVER** touch when **hot!**
9. **Fuel Tank** – Fill with unleaded gasoline. Reference Table 3 for fuel tank capacity. For additional information refer to Honda engine owner's manual.
10. **Dipstick/Oil Filler Cap** – Remove this cap to determine if the engine oil is low. Add oil through this filler port as recommended in Table 4.
11. **Oil Drain Plug** – Remove this plug to remove oil from the engine's crankcase.
12. **Engine ON/OFF Switch** – **ON** position permits engine starting, **OFF** position stops engine operation.

ASSEMBLY AND INSTALLATION

UNPACKING THE TROWEL

The trowel is shipped with the handlebar in the folded or stowed position (Figure 5).

1. To place the handlebar in the operational position, simply turn the star wheel counterclockwise to release it from its locked/stowed position.
2. Next, pull back on the handlebar and place the handlebar in the desired position. Turn star wheel clockwise to lock handlebar firmly in place so that it will not move or slip.

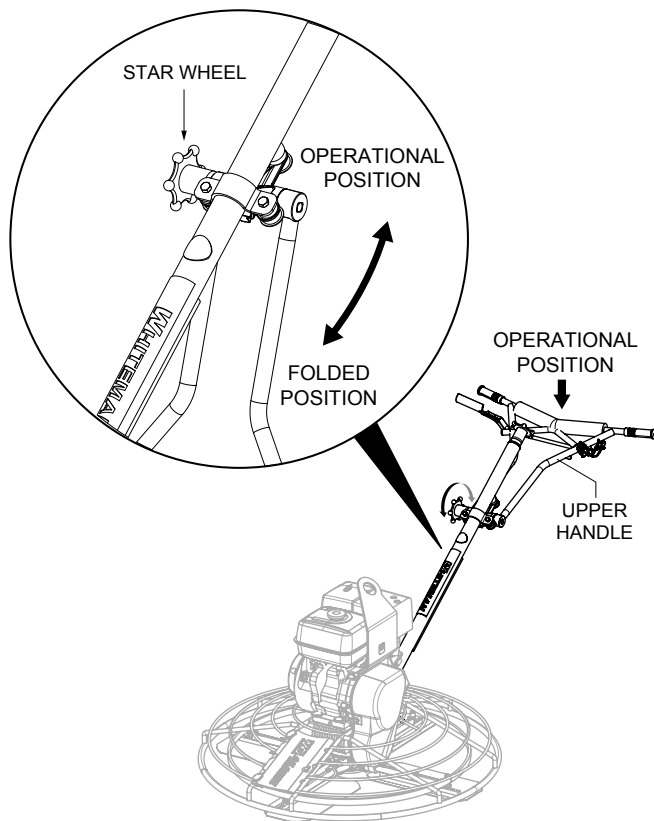

Figure 5. Trowel Folded and Operational Positions

ASSEMBLY AND INSTALLATION

Before the trowel can be put into operation there are some components that must be installed. This section provides general instructions on how to install those components.

MAIN HANDLE TUBE INSTALLATION

1. Attach the main handle tube to the gearbox using the supplied hardware as shown in Figure 6.

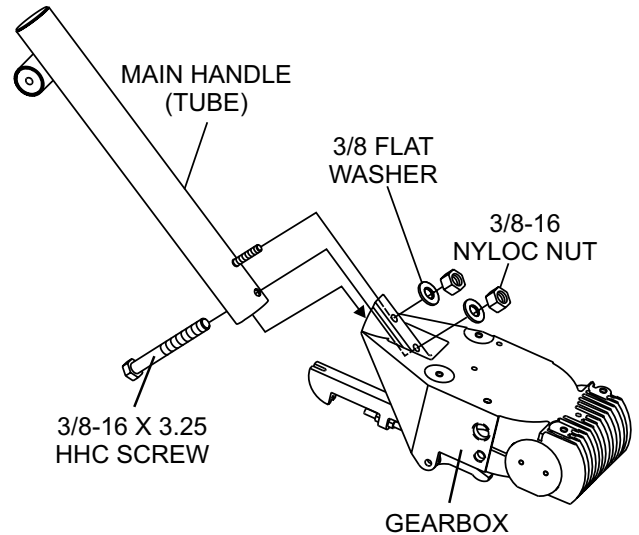

Figure 6. Handle Installation

2. The handlebar is already attached to the main handle tube.
3. If readjustment is necessary, loosen the star wheel as shown in Figure 7 and move the handlebar to the desired position.

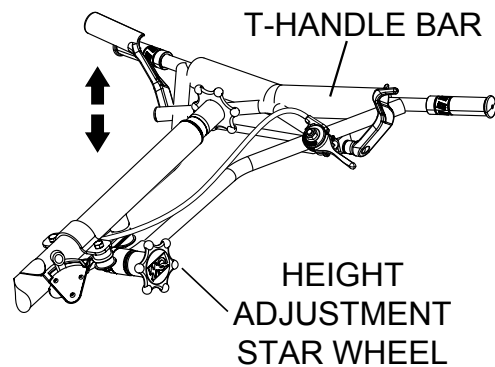

Figure 7. Handlebar Adjustment

ASSEMBLY AND INSTALLATION

BLADE PITCH CABLE INSTALLATION

1. For trowels equipped with a **Standard** handle (SXHC), simply turn the **star wheel** counterclockwise to pitch the blades flat. This will release the tension on the blade pitch cable (Figure 8).

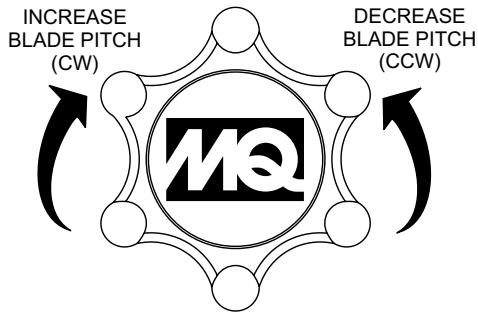

Figure 8. Adjusting Cable Blade Pitch (Standard Handle)

2. For trowels equipped with a **Quick Pitch™ T-handle** (QXHC), simply squeeze the trigger lock and push the **T-handle** towards the engine to pitch the blades downward. Pushing the **T-handle** towards the engine will cause the blades to lay flat (Figure 9). This will release the tension on the blade pitch cable.

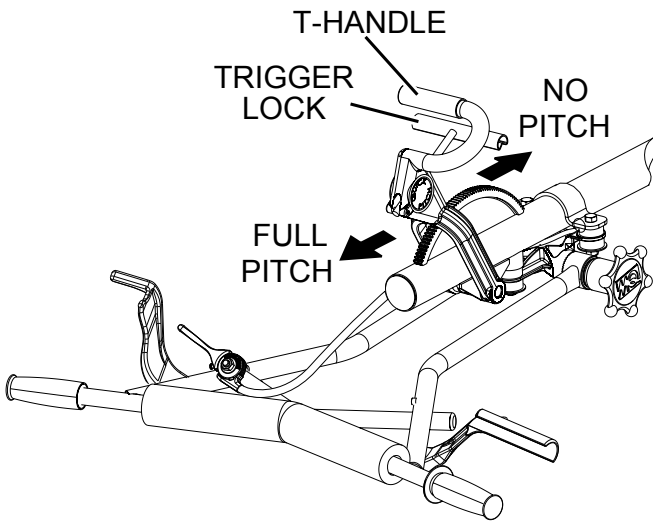

Figure 9. Adjusting Cable Blade Pitch (Quick-Pitch™ Handle)

WARNING

The **Quick Pitch™ T-handle** is under spring tension and can snap in the direction of force (toward user) if not firmly grasped which may cause bodily injury.

3. Remove brass set nut #1 from the blade pitch cable end. See Figure 10.

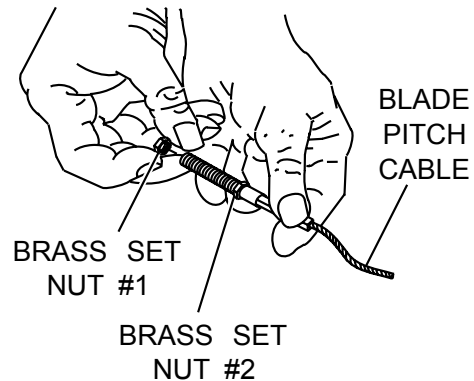

Figure 10. Blade Pitch Cable

4. Thread the brass set nut #2 towards the cable as far as possible. See Figure 10.
5. Insert the cable end through the yoke eyelet (Figure 11). Tighten brass set nut #1 by hand to remove all the slack from the cable.

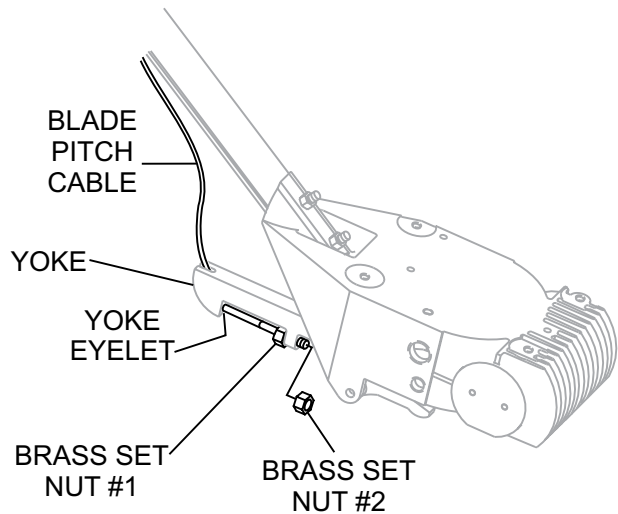

Figure 11. Cable Yoke Attachment

6. Using a wrench, tighten the brass set nut #2 up against the yoke boss. This will lock the cable in place.
7. Using a wrench, tighten the brass set nut #1 against the yoke boss.

ASSEMBLY AND INSTALLATION

THROTTLE CABLE INSTALLATION

Refer to Figure 12 for the location of components.

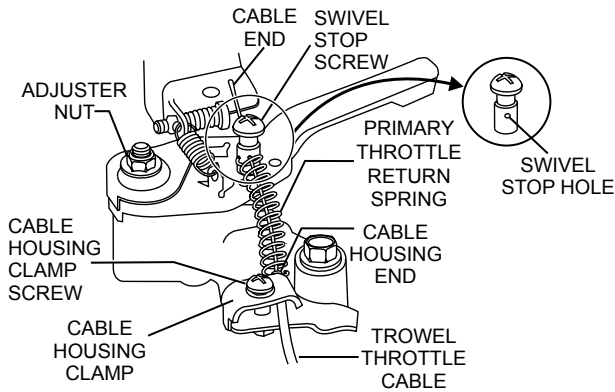

Figure 12. Throttle Cable Installation

1. Uncoil the throttle cable and housing.
2. Check that the throttle cable is fed through the tube on the underside of the handle and secured to the upper handle and main tube with the zip ties.
3. Place the throttle in the run position (Figure 13).
4. Back off both the cable housing clamp screw and the swivel stop screw.
5. Place the primary throttle return spring (P/N 21746) between the cable housing clamp and the swivel stop screw.
6. Feed the cable assembly through the cable housing clamp, primary throttle return spring, and swivel stop hole, until the cable housing extends under the housing clamp to its far edge.
7. On the throttle lever, slightly loosen the locking nut and cable retaining screw as shown in Figure 13.
8. Ensure that the cable housing is seated in the throttle cable receiver as shown in Figure 13.
9. Route throttle wire past the cable retaining screw (Figure 13) approximately 1/2". To secure throttle wire, tighten the cable retaining screw.

10. Adjust cable tension by loosening or tightening the locking nut and cable retaining screw on the throttle lever (see Figure 13)

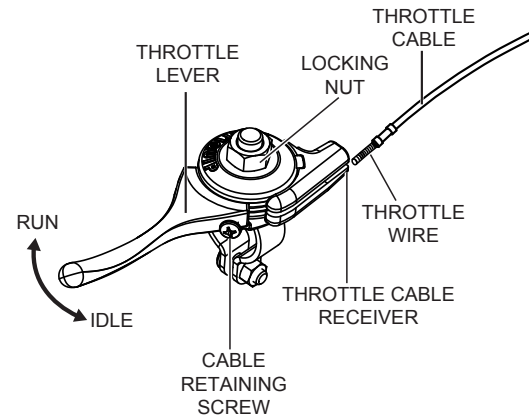

Figure 13. Adjusting Cable Tension

NOTICE

If the throttle lever does not return to the "neutral" position with throttle backed off, loosen adjusting nut 1/2 turn at a time, tighten and recheck. Readjust throttle tension as necessary.

INSTACLUTCH CABLE INSTALLATION

1. Uncoil the free end of the clutch cable.
2. Check that the clutch cable (Figure 14) is attached to the handlebar cable anchor.

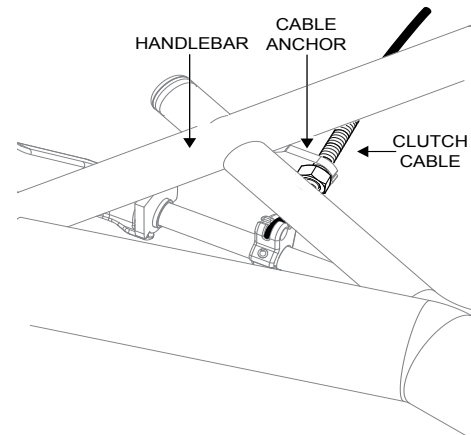

Figure 14. Handlebar Clutch Cable

3. Check that the clutch cable is fed along the tube and secured with zip ties.

ASSEMBLY AND INSTALLATION

- Using a 7/16" wrench remove the three 1/4" retaining bolts (Figure 15) that secure the clutch cover to the frame.

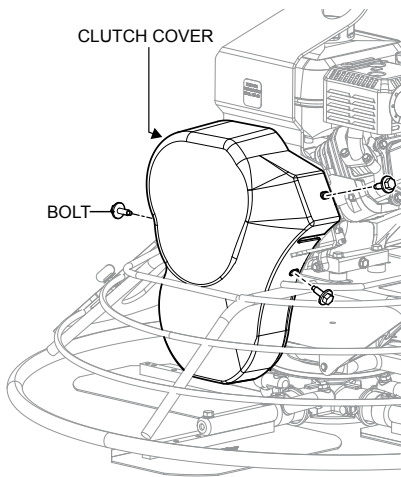

Figure 15. Clutch Cover Removal

- Route the clutch cable (Figure 16) underneath the top most rung of the guard ring.

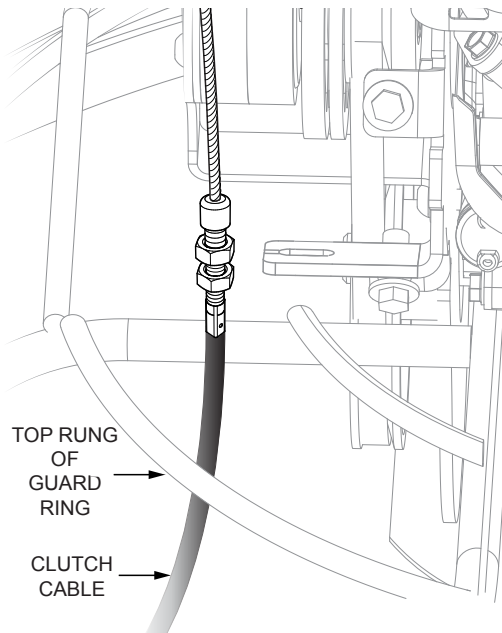

Figure 16. Clutch Cable Routing

- Remove the 5/16" outer nut (Figure 17) and rubber cap from the threaded end on the clutch cable.

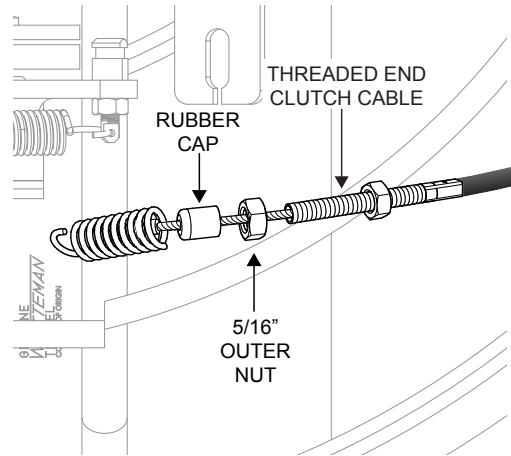

Figure 17. Outer Nut And Rubber Cap Removal

- Adjust the 5/16" inner nut (Figure 18) away from the threaded end on the clutch cable to the inner nut.

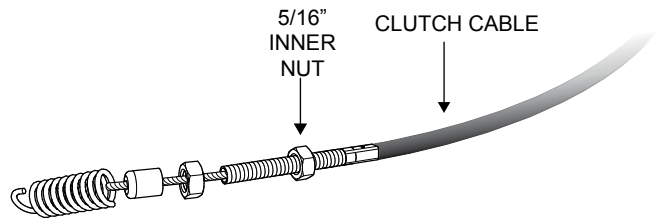

Figure 18. Inner Nut Adjustment

- Insert the exposed cable (Figure 19) into the cable slot on the cable anchor.

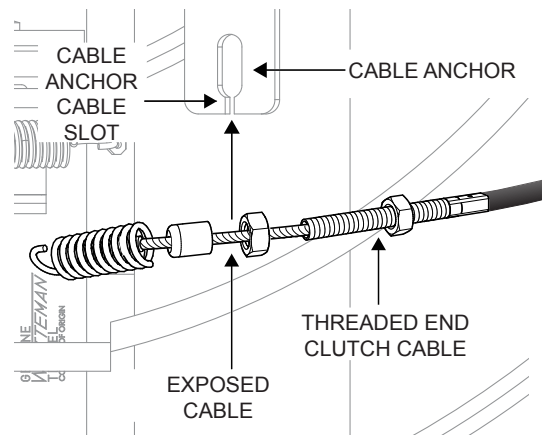

Figure 19. Inserting Clutch Cable Into Cable Anchor

ASSEMBLY AND INSTALLATION/INSPECTION

9. Connect the clutch cable to the clutch anchor by placing the spring loop over the clutch anchor flats as shown in Figure 20. Use needle nose pliers to slide the spring loop fully into the groove.

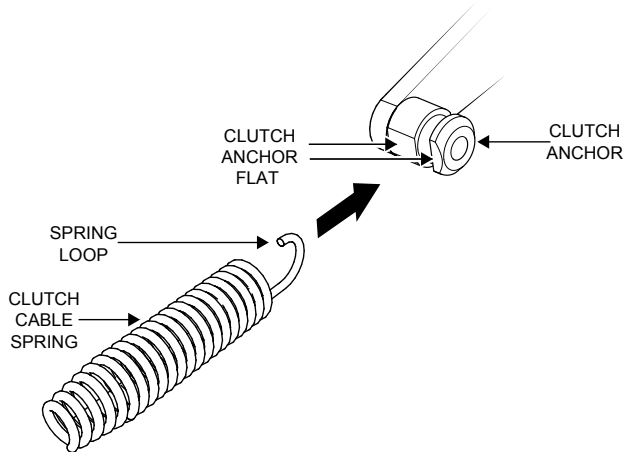

Figure 20. Spring Loop Attachment.

10. Tighten the inner nut (Figure 21) against the clutch cable support bracket until there is no longer any slack in the cable between the threaded cable end and the clutch cable spring.

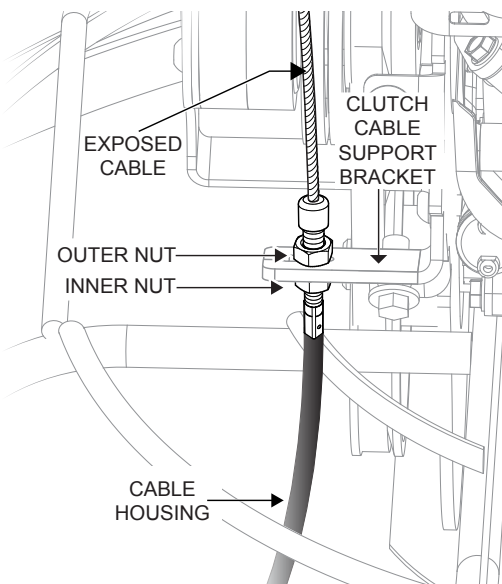

Figure 21. Attaching Clutch Cable To Cable Support Bracket

11. Using two 1/2" wrenches tighten the inner and outer nut against the clutch cable support bracket.

Before Starting

1. Read all safety instructions at the beginning of manual.
2. Clean the trowel, removing dirt and dust, particularly the engine cooling air inlet, carburetor and air cleaner.
3. Check the air filter for dirt and dust. If air filter is dirty, replace air filter with a new one as required.
4. Check carburetor for external dirt and dust. Clean with dry compressed air.
5. Check fastening nuts and bolts for tightness.

Engine Oil Check

1. To check the engine oil level, place the trowel on secure level ground with the engine stopped.
2. Remove the dipstick from the engine oil filler hole (Figure 22) and wipe clean.

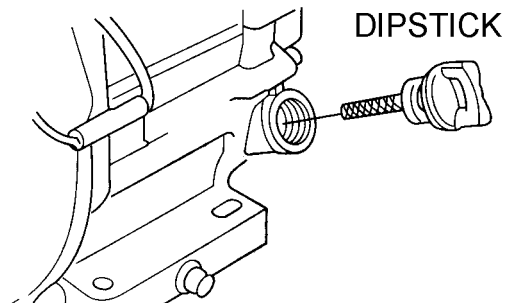

Figure 22. Engine Oil Dipstick Removal

3. Insert and remove the dipstick without screwing it into the filler neck. Check the oil level shown on the dipstick.

- If the oil level is low (Figure 23), fill to the edge of the oil filler hole with the recommended oil type as listed in Table 4. Reference Table 3 for maximum engine oil capacity.

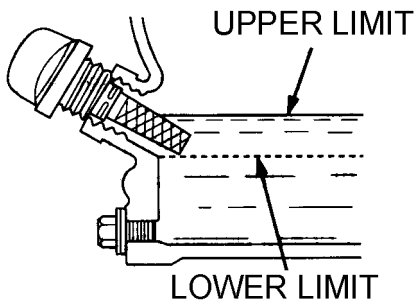

Figure 23. Engine Oil Dipstick (Oil Level)

Table 4. Oil Type		
Season	Temperature	Oil Type
Summer	25°C or Higher	SAE 10W-30
Spring/Fall	25°C~10°C	SAE 10W-30/20
Winter	0°C or Lower	SAE 10W-10

! DANGER



EXPLOSIVE FUEL!

Motor fuels are highly flammable and can be dangerous if mishandled. **DO NOT** smoke while refueling. **DO NOT** attempt to refuel the trowel if the engine is hot! or running.

Fuel Check

- Visually inspect to see if fuel level is low. If fuel is low, replenish with unleaded fuel.
- When refueling, be sure to use a strainer for filtration. **DO NOT** top-off fuel. Wipe up any spilled fuel immediately.

Gearbox Oil

- Determine if the gearbox oil is low by removing the oil plug located on the side of the gearbox. (Figure 24) This plug will be marked by the "check" decal. The correct level of the lubrication oil should be to the bottom of the fill plug.

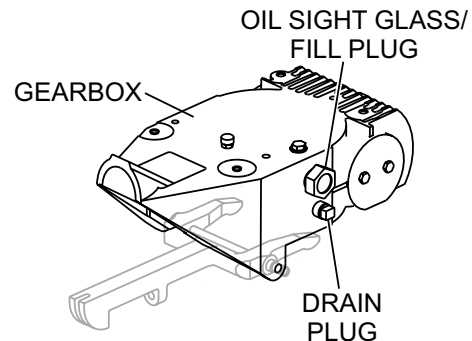

Figure 24. Gearbox

- If lubrication oil begins to seep out as the drain plug is being removed, then it can be assumed that the gearbox has a sufficient amount of oil.
- If lubrication oil does not seep out as the drain plug is being removed, fill with type ISO 680 (P/N 10139) gearbox lubricant oil until the oil filler hole overflows.

V-Belt Check

A worn or damaged V-belt can adversely affect the performance of the trowel. If a V-belt is defective or worn simply replace the V-belt as outlined in the maintenance section of this manual.

Belt Guard Check

Check for damage, loose or missing hardware.

Blade Check

Check for worn or damaged blades. Check to see if one blade is worn out while the others look new. If this is the case there could be a blade pitch problem. Refer to the maintenance section of this manual for blade pitch adjustment procedure. Replace any worn blades.

Operation

This section is intended to assist the operator with the initial start-up of the walk-behind trowel. It is extremely important that this section be read carefully before attempting to use the trowel in the field. **DO NOT** use your trowel until this section is thoroughly understood.

Lifting the Trowel Onto a Slab

Extra care should be taken when lifting the trowel off the ground. Serious damage to the machine or personal injury could be caused by dropping a trowel.

WARNING

NEVER attempt to lift this machine alone. **NEVER** lift the trowel by the guard ring as it may rotate and cause injury.

ALWAYS make certain the handle is secure and use only the manufacturer's approved lifting point. The trowel may be lifted at the center lifting bale by crane or other lifting device of adequate capacity.

NOTICE

DO NOT attempt to operate the trowel until the Safety, General Information and Inspection sections of this manual have been read and thoroughly understood.

NOTICE

The trowel is heavy and awkward to move around. Use proper heavy lifting procedures and **DO NOT** lift the trowel by the guard rings.

Lifting Bale

The lift bale provides an optimal lift point for lifting the trowel. When lifting the trowel onto a concrete slab, attach a chain or rope to the lifting bale. Make sure the lifting device has adequate lifting capacity to lift the trowel.

Using a crane or forklift (Figure 25) to lift the trowel is highly recommended, and is perfectly safe for the trowel. **ALWAYS** use extra care when lifting the trowel off the ground.

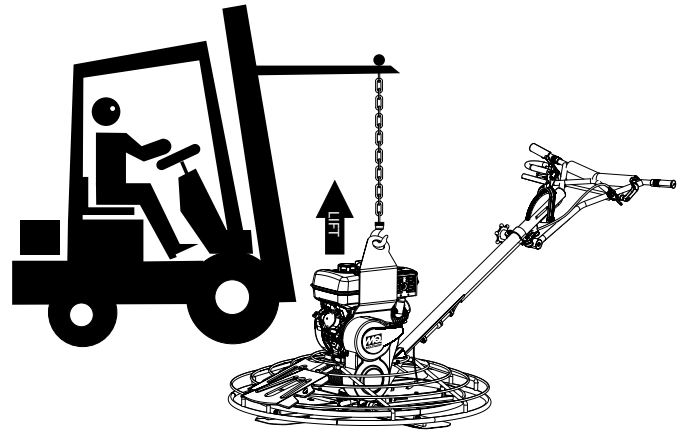

Figure 25. Lifting the Trowel

NEVER lift the trowel to unnecessary heights. **DO NOT** stand underneath the trowel while it is being lifted. Serious damage to the machine or personal injury could be caused by dropping a trowel.

Starting the Engine

1. Turn the engine start/stop switch to the "ON" position (Figure 26).

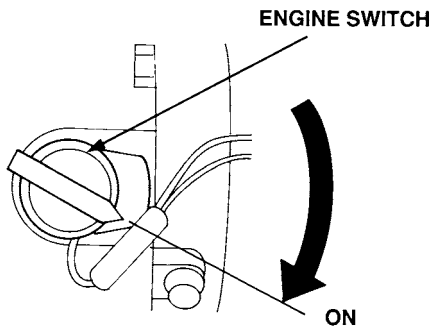

Figure 26. Engine ON/OFF Switch (ON Position)

2. Place the engine fuel valve lever (Figure 27) in the "ON" position.

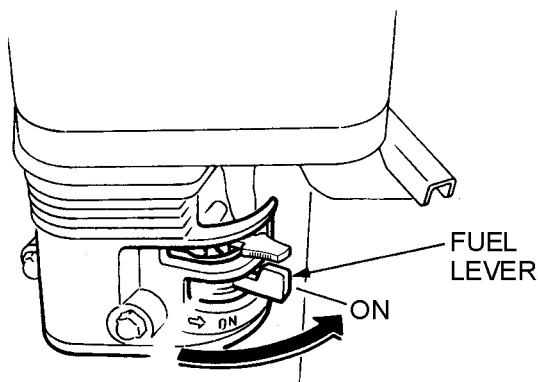

Figure 27. Engine Fuel Valve Lever (ON)

3. Push the *throttle lever* (Figure 28) in the "idle" position.

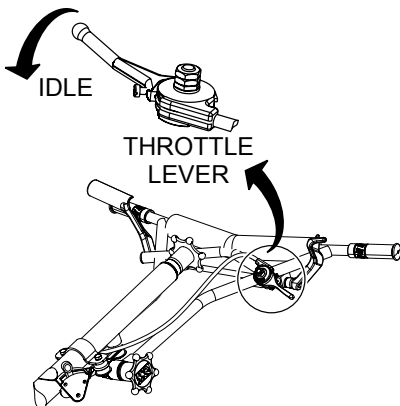

Figure 28. Throttle (Idle Position)

4. Place the *choke lever* (Figure 29) in the "OPEN" position.

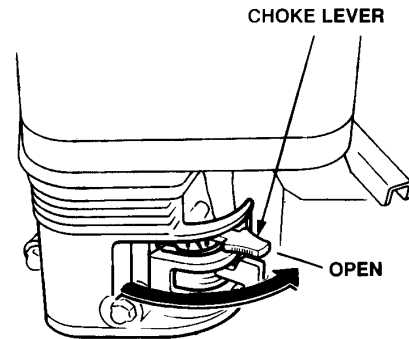

Figure 29. Choke Lever Open

5. Grasp the starter grip (Figure 30) and slowly pull it out. The resistance becomes the hardest at a certain position, corresponding to the compression point. Pull the starter grip briskly and smoothly for starting.

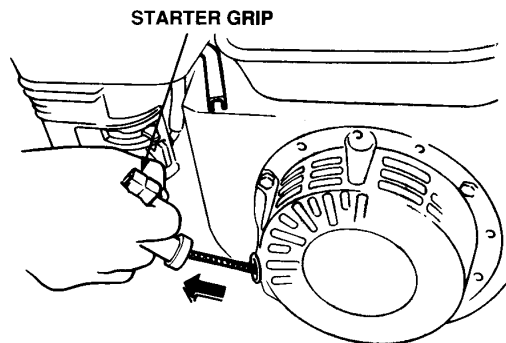

Figure 30. Starter Grip

6. If the engine has started, slowly return the choke lever (Figure 31) to the **CLOSED** position. If the engine has not started repeat steps 1 through 5.

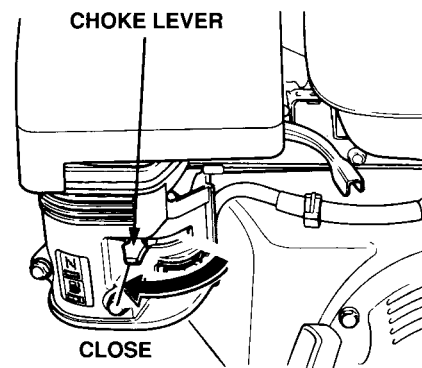

Figure 31. Choke Lever Closed

7. Before the trowel is placed into operation, run the engine for several minutes. Check for fuel leaks, and noises that would associate with a loose guard ring and/or covers.

To Begin Troweling

1. To begin troweling, place the throttle lever (Figure 32) in the "RUN" position.

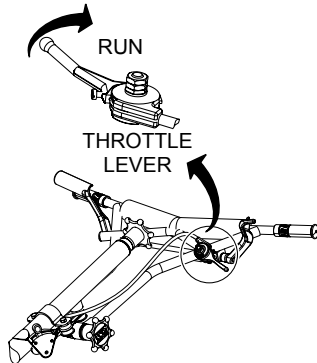

Figure 32. Throttle Lever (Run)

2. Squeeze the pull the clutch lever (Figure 33) to begin 4-blade rotation. Verify that the blades are rotating.

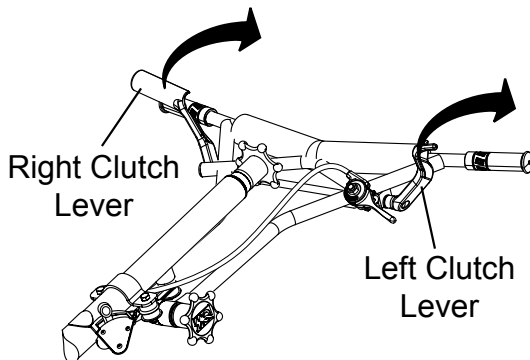

Figure 33. Clutch Levers (Blade Activation)

Concrete Finishing Techniques

The following steps are intended as a basic guide to machine operation, and are not to be considered a complete guide to concrete finishing. We suggest that all operators (experienced and novice) read "*Slabs on Grade*" published by the *American Concrete Institute, Detroit, Michigan*. Read the "Training" section of this manual for more information.

Pitching the Blades (Standard Handle)

To pitch the blades upwards using the "Standard" handle, (Figure 34) simply turn the *star-wheel* clockwise. Turning the star wheel counter clockwise will cause the blades to lay flat.

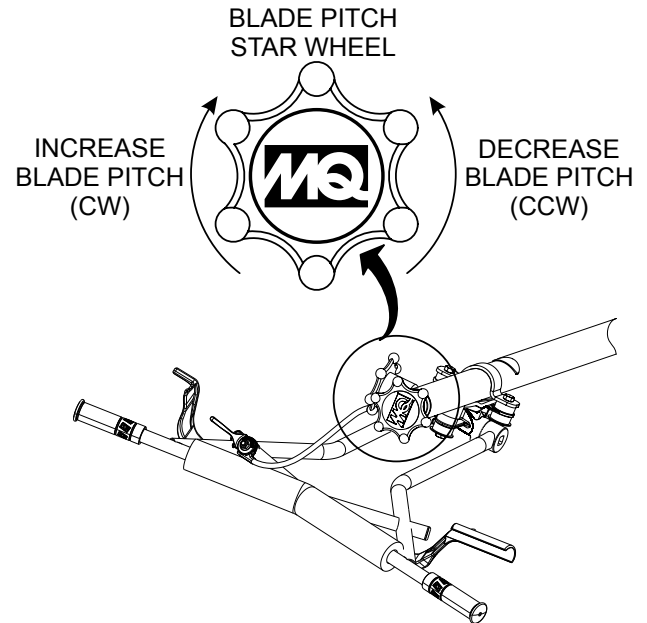

Figure 34. Blade Pitch Star Wheel

Pitching the Blades (Quick Pitch™ Handle)

To pitch the blades upwards using the "Quick Pitch™" handle, (Figure 35) simply *pull* the T-handle backwards while squeezing the trigger. Pushing the T-handle forward will cause the blades to lay flat.

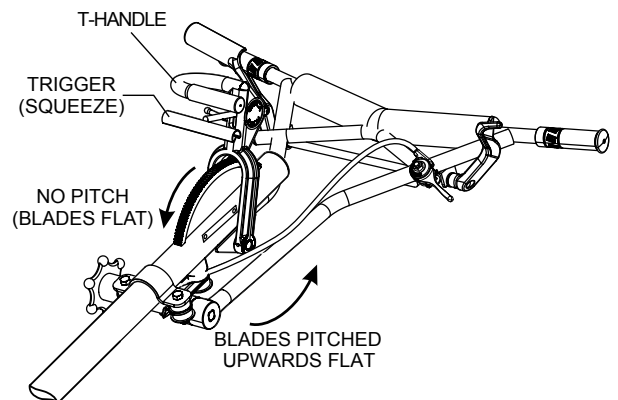

Figure 35. Blade Pitch T-Handle

OPERATION

Maneuvering the Trowel

1. Get into the operator's position behind the handle. With a secure foothold and a firm grasp on the handle and clutch levers, slowly increase the engine speed until the desired blade speed is obtained.
2. Figure 36 below illustrates a typical walk-behind trowel application. Practice maneuvering the trowel. The trick is to let the trowel do the work.

3. Continue to practice maneuvering the trowel. Try to practice as if you were finishing a slab of concrete. Practice edging and covering a large area.

Remember a good finishing technique is to work backwards. Be careful when moving backwards so that hazards can be avoided. The best way to get accustomed to the trowel is repeated use.

To move the trowel to the operator's left, **lift up** on the handle, to move the trowel to the right **push down** on the handle.

Remember! that if you let go of the trowel, just **step away** and let the trowel come to a complete **STOP** before trying to recover the trowel.

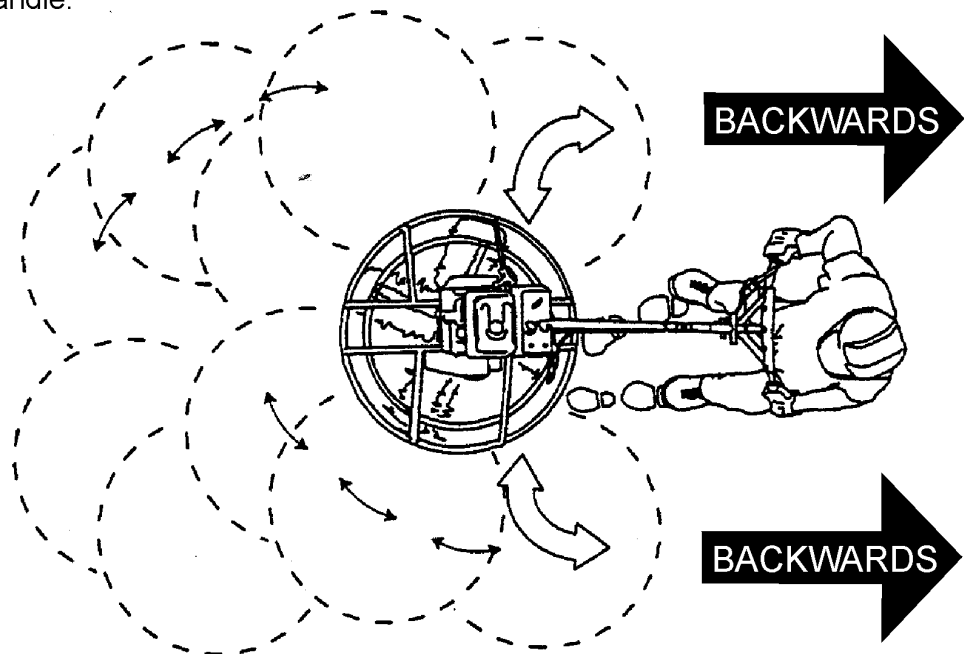

The best method for finishing concrete is to slowly walk **backwards** with the trowel, guiding the trowel from side to side. This will cover all footprints on wet concrete.

Figure 36. Maneuvering the Trowel

CAUTION

NEVER place your **feet** or **hands** inside the guard rings while starting or operating this equipment.

CAUTION

ALWAYS keep clear of **rotating** or **moving** parts while operating this equipment.

Stopping The Engine

1. Move the throttle lever to the (Figure 37) "IDLE" position and run the engine for three minutes at low speed.

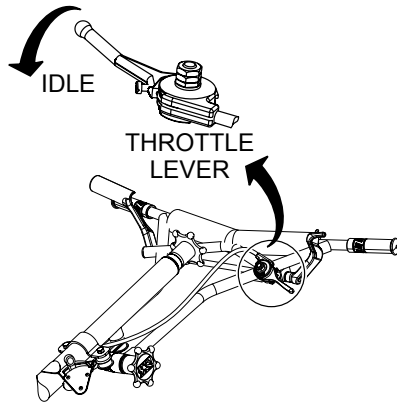

Figure 37. Throttle Lever (Idle)

2. After the engine cools, turn the engine start/stop switch to the "OFF" position (Figure 38).

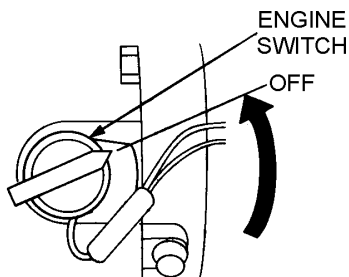

Figure 38. Engine ON/OFF Switch (OFF Position)

3. Close the fuel shut-off valve (Figure 39) by moving the fuel valve lever to the **OFF** position.

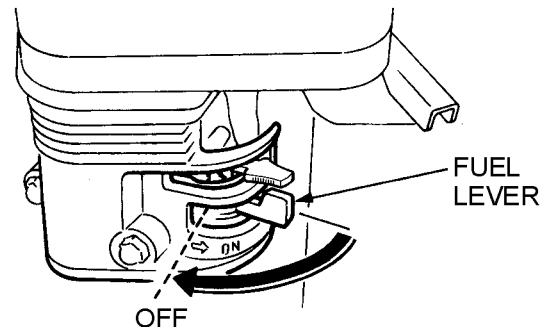

Figure 39. Fuel Valve Lever (OFF)

NOTICE

Trowel blades should be changed when they fail to finish concrete in a satisfactory manner.

Blades are a vital part of finishing concrete. This trowel, or finisher, has been designed to finish concrete and the blades are built to stringent quality standards out of the finest steel.

If you need replacement blades, consult the parts list in this manual for part numbers and order them from your Multiquip parts dealer or importer.

Combo Blades

This trowel is equipped with combination float/finish (Figure 40) blades as original equipment. These blades have been designed for optimum performance in both the floating and finishing operations. These blades are versatile and should take care of most troweling needs.

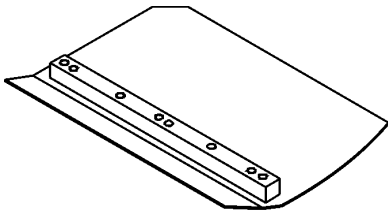

Figure 40. Combination Blade

Finish Blades (Optional)

These blades (Figure 41) have been specifically designed for finish operations with this trowel. They will provide a premium surface finishing capability from your trowel. They should only be used after the concrete has set to the point where the trowel does not sink into the concrete when placed on it.

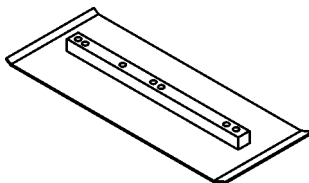

Figure 41. Finish Blade

Clip-On Float Blades (Optional)

These blades will clip (Figure 42) onto an existing installed blade, allowing your finisher to float on “wet” concrete so that the troweling operation can begin as early as possible. These blades are easily removable, so that after the floating operation, when the concrete is sufficiently cured, they can be removed to expose the finish blades for continued troweling.

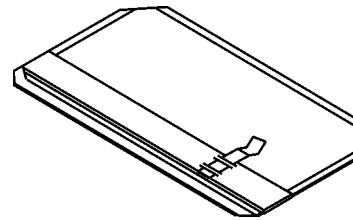

Figure 42. Clip-On Float Blade

Float Discs (Optional)

These round discs (Figure 43) attach to the spiders and allow the machine to “float” on “wet” concrete. The disc design allows early floating and easy movement from wet to dry areas. They are also very effective in embedding large aggregates and surface hardeners.

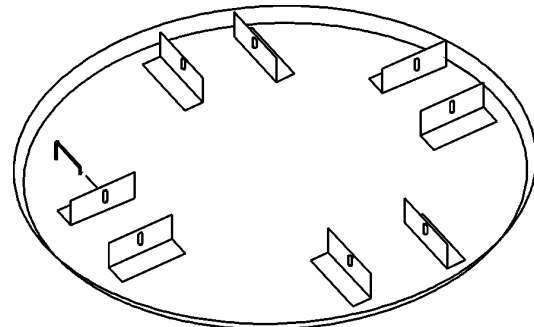

Figure 43. Float Disc/Pan

NOTICE

For optimum panning performance blade speed must be changed. Use Low Speed Kit. Reference Engine and Clutch Assembly in parts section of this manual.

Trowel Arm Adjustment Tool (Optional)

If blades show uneven wear patterns or some tend to wear out faster than others, the trowel arms may need to be adjusted. A special tool is available (Figure 44) that will adjust all of the trowel arms consistently. The Trowel Arm Fixture P/N is 1817.

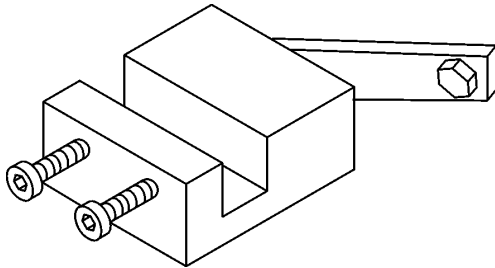

Figure 44. Trowel Arm Adjustment Fixture

Quick Pitch™ Handle (Optional)

This feature (Figure 45) is not standard equipment on this model walk-behind trowel. To order this feature please contact MQ unit sales.

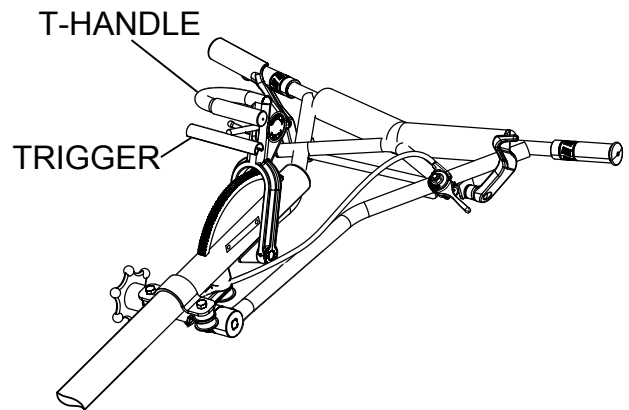

Figure 45. Quick Pitch™ Handle (Option)

The Quick Pitch™ Handle feature allows the operator to adjust the pitch of the blades by grasping the handle, then squeezing the trigger lever and then moving the handle either forward or backwards to achieve the desired blade pitch.

MAINTENANCE

Table 5. Engine Maintenance Schedule

DESCRIPTION (3)	OPERATION	BEFORE EACH USE	FIRST MONTH OR 20 HRS.	EVERY 6 MONTHS OR 100 HRS.	EVERY YEAR OR 300 HRS.	EVERY 2 YEARS OR 500 HRS.
Engine Oil	Check	X				
	Change		X	X		
Engine Oil Filter	Replace	Every 200 Hrs.				
Air Cleaner	Check	X				
	Clean			X (1)		
	Change					X (*)
Spark Plugs	Check/Adjust			X		
	Replace				X	
Spark Arrester	Clean			X		
Fuel Filter	Replace				X (2)	
Fuel Tube	Check	Every 2 years (replace if necessary) (2)				

* - Replace the paper filter element only.

(1) Service more frequently when used in **DUSTY** areas.

(2) These items should be serviced by your service dealer, unless you have the proper tools and are mechanically proficient. Refer to the HONDA Shop Manual for service procedures.

(3) For commercial use, log hours of operation to determine proper maintenance intervals.

Table 6. Trowel Maintenance Schedule

ITEM	OPERATION	DAILY	Periodic Maintenance Interval		
			Every 50-60 Hrs	Every 200-300 Hrs	Every 2000-2500 Hrs
V-Belt	Check/Replace	X			
Relube Trowel Arms	Grease		X		
Blades	Check/Replace		X		
Trowel Arms	Remove/Clean			X	
Thrust Collar/Bushing	Remove/Clean			X	
Blade Arms	Adjust			X	
Arm Bushing	Remove/Replace				X
Wear Ring	Remove/Replace				X
Thrust Collar Bearing	Remove/Replace				X
Pitch Control Cable	Check				X
Clutch	Remove/Clean			X	

General maintenance practices are crucial to the performance and longevity of your trowel. This equipment requires routine cleaning, blade and trowel arm inspection, lubrication and V-belt inspection for wear and damage. Reference Table 5 and Table 6 for scheduled engine and trowel maintenance.

The following procedures, devoted to maintenance, can prevent serious trowel damage or malfunctioning.

NOTICE

Reference **HONDA** engine manual supplied with your trowel for more detailed engine maintenance and troubleshooting.

CAUTION



ALWAYS allow the engine to cool before servicing. **NEVER** attempt any maintenance work on a hot engine.

CAUTION

ALWAYS disconnect the spark plug wire from the spark plug and secure away from the engine before performing maintenance or adjustments on the machine.

WARNING



Some maintenance operations may require the engine to be run. Ensure that the maintenance area is well ventilated. Gasoline engine exhaust contains poisonous carbon monoxide gas that can cause unconsciousness and may result in **DEATH**.

GENERAL CLEANLINESS

Clean the trowel daily. Remove all dust and slurry buildup. If the trowel is steam-cleaned, ensure that lubrication is accomplished **AFTER** steam cleaning.

ENGINE CHECK

Check daily for any oil and/or fuel leakage, thread nut and bolt tightness, and overall cleanliness.

Engine Air Cleaner

DANGER



DO NOT use gasoline or low flash point solvents for cleaning the air cleaner, the possibility exists of fire or explosion which can cause damage to the equipment and severe bodily harm or even **DEATH!**

CAUTION



Wear protective equipment such as approved safety glasses or face shields and dust masks or respirators when cleaning air filters with compressed air.

This engine is equipped with a replaceable, high-density paper air cleaner element. See Figure 46 for air cleaner components.

1. Remove the air cleaner cover and foam filter element.
2. Tap the paper filter element several times on a hard surface to remove dirt, or blow compressed air not exceeding 30 psi (207 kPa, 2.1 kgf/cm²) through the filter element from the inside out. **NEVER** brush off dirt. Brushing will force dirt into the fibers. Replace the paper filter element if it is excessively dirty.
3. Clean foam element in warm, soapy water or nonflammable solvent. Rinse and dry thoroughly. Dip the element in clean engine oil and completely squeeze out the excess oil from the element before installing.

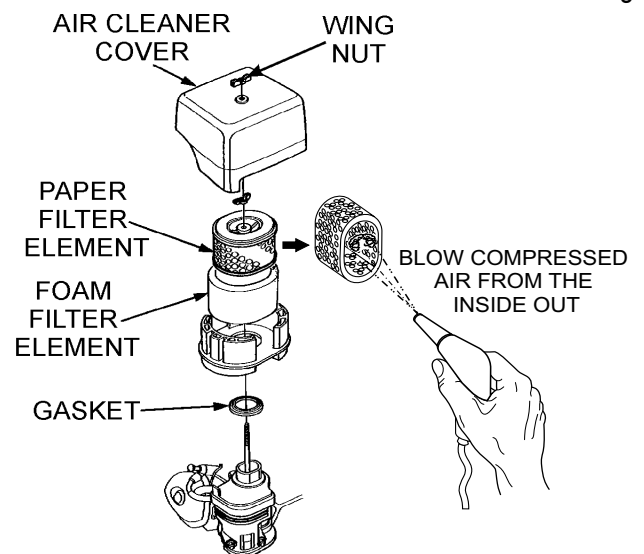

Figure 46. Engine Air Cleaner

NOTICE

Operating the engine with loose or damaged air cleaner components could allow unfiltered air into the engine causing premature wear and failure.

ENGINE OIL

1. Drain the engine oil when the oil is warm as shown in Figure 47.
2. Remove the oil drain bolt and sealing washer and allow the oil to drain into a suitable container.
3. Replace engine oil with recommended type oil as listed in Table 4. For engine oil capacity, see Table 3 (engine specifications). **DO NOT** overfill.
4. Reinstall drain bolt with sealing washer and tighten securely.

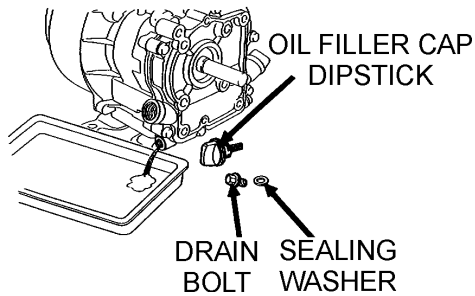

Figure 47. Draining Engine Oil

SPARK PLUG

NOTICE

NEVER use a spark plug of incorrect heat range.

1. Remove and clean spark plug (Figure 48) with a wire brush if it is to be reused. Discard spark plug if the insulator is cracked or chipped.
2. Using a feeler gauge adjust spark plug gap to 0.028 ~0.031 inch (0.7~0.8 mm).
3. Thread spark plug into cylinder hole by hand to prevent cross-threading, then tighten securely.

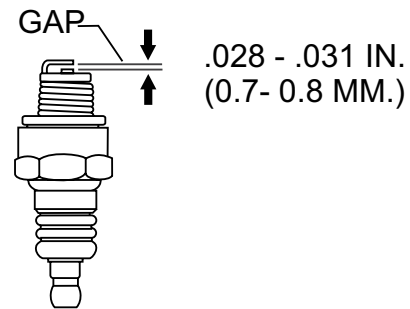

Figure 48. Spark Plug Gap

V-BELT

Visually examine the V-belt (Figure 49) and determine if it is full of tiny cracks, frayed, has pieces of rubber missing, is peeling or otherwise damaged.

Also, examine the belt and determine if it is **oil soaked** or "**glazed**" (hard shiny appearance on the sides of the belt). Either of these two conditions can cause the belt to run hot, which can weaken it and increase the danger of it breaking.

If the V-belt exhibits any of the above wear conditions replace the V-belt immediately.

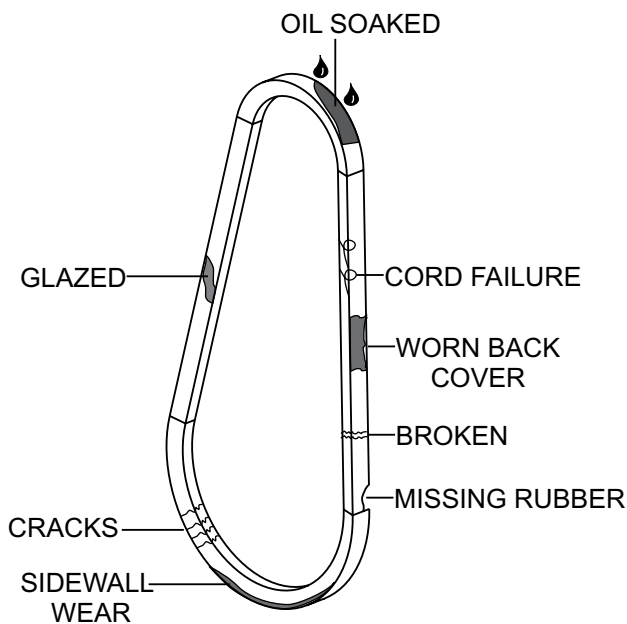

Figure 49. V-Belt Inspection

SPARK ARRESTER CLEANING

Clean the spark arrester every 6 months or 100 hours.

1. Remove the 4 mm screw (3) from the exhaust deflector, then remove the deflector. See Figure 50
2. Remove the 5 mm screw (4) from the muffler protector, then remove the muffler protector.
3. Remove the 4 mm screw from the spark arrester, then remove the spark arrester.

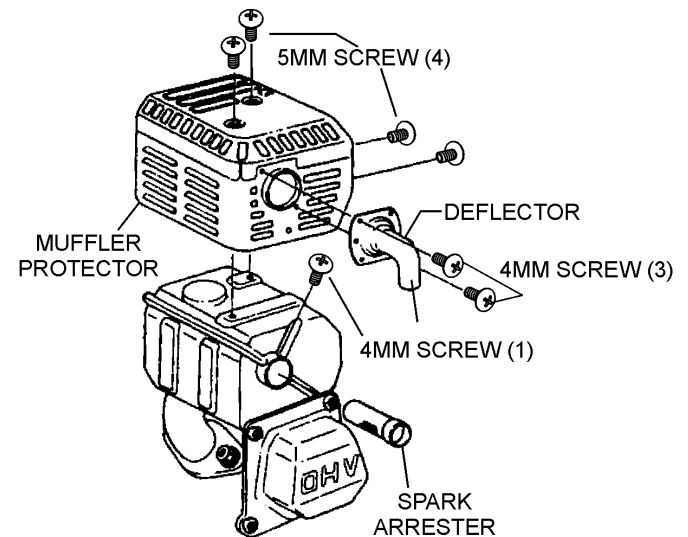

Figure 50. Spark Arrester Removal

4. Carefully remove carbon deposits from the spark arrester screen (Figure 51) with a wire brush.

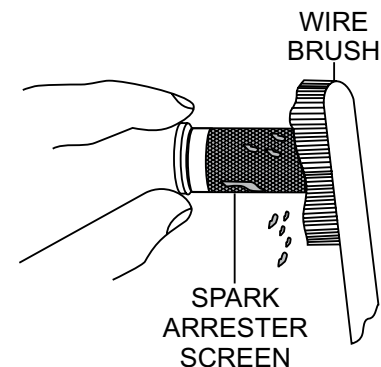

Figure 51. Cleaning The Spark Arrester

5. If the spark arrester is damaged and has breaks or holes, replace with a new one.
6. Reinstall the spark arrester and muffler protector in reverse order of disassembly.

BLADE PITCH ADJUSTMENT PROCEDURE

The maintenance adjustment of blade pitch is an adjustment that is made by a bolt (Figure 52) on the arm of the trowel arm lever. This bolt is the contact point of the trowel arm lever to the lower wear plate on the thrust collar. The goal of the adjustment is to promote consistent blade pitch and finishing quality. Adjustments are made by tightening or loosening the blade pitch adjustment bolt.

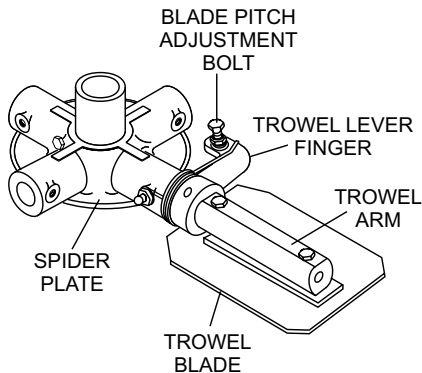

Figure 52. Blade Pitch Adjustment Bolt

Watch for the following indications when determining if blade pitch adjustments are necessary:

- Is the machine wearing out blades unevenly, (i.e. one blade is completely worn out while the others look new)?
- Does the machine have a perceptible rolling or bouncing motion when in use?
- Look at the machine while it is running, do the guard rings “rock up and down” relative to the ground?

If it is determined that blade pitch adjustments are required do the following:

NOTICE

Before any blade pitch adjustments can be made it is essential to have a clean level area free of dirt and debris to test the trowel. Any unlevel spots in the floor or debris under the trowel blades will give an incorrect perception of adjustment. Ideally, a 5 x 5 ft. (1.5 x 1.5 meter), three-quarter inch (19 mm) thick **FLAT** steel plate should be used for testing.

1. Place the trowel on a flat, level area free of dirt and debris.

2. Pitch the blades as flat as possible. The pitch adjustment bolts (Figure 53) should all barely make contact (0.10 inch max. clearance) with the **lower wear plate** on the spider. All pitch alignment bolts should be spaced the same distance from the lower wear plate. If one is not making contact, adjustment will be necessary.

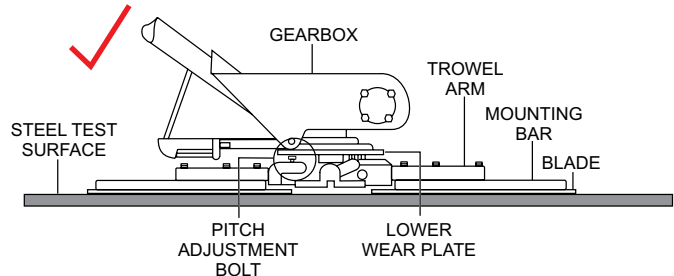

Figure 53. Correct Blade Pitch (Flat)

3. Adjust the “**high**” bolts down to the level of the one that is not touching, or adjust the “**low**” bolt up to the level of the higher ones. If possible, adjust the low bolt up to the level of the rest of the bolts. This is the fastest way, but may not always work. Verify after adjustment the blades pitch correctly.
4. Blades that are incorrectly adjusted often will not be able to pitch flat. This can occur if the adjusting bolts are raised too high. Conversely, adjusting bolts that are too low will not allow the blades to be pitched high enough for finishing operations.
5. If, after making blade pitch adjustments the machine is still finishing poorly, blades, trowel arms, and trowel arm bushings may be suspect and should be looked at for adjustment, wear, or damage.
6. Figure 54 illustrates, “incorrect alignment”, worn spider bushings or bent trowel arms.

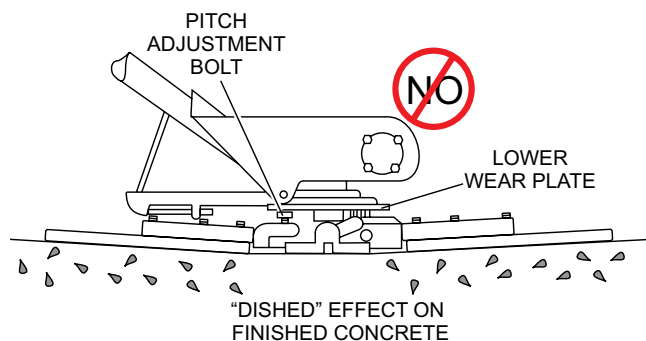

Figure 54. Incorrect Spider Plate Alignment

SPIDER REMOVAL

Remove the spider assembly from the gearbox shaft as follows:

1. Locate the cone point square head set screw (Figure 55) and attached jam nut found on the side of the spider assembly.
2. Loosen the jam nut and cone point square head set screw.
3. Carefully lift the upper trowel/gearbox assembly off of the spider assembly. A slight tap with a rubber mallet may be necessary to dislodge the spider from the main shaft of the gearbox.

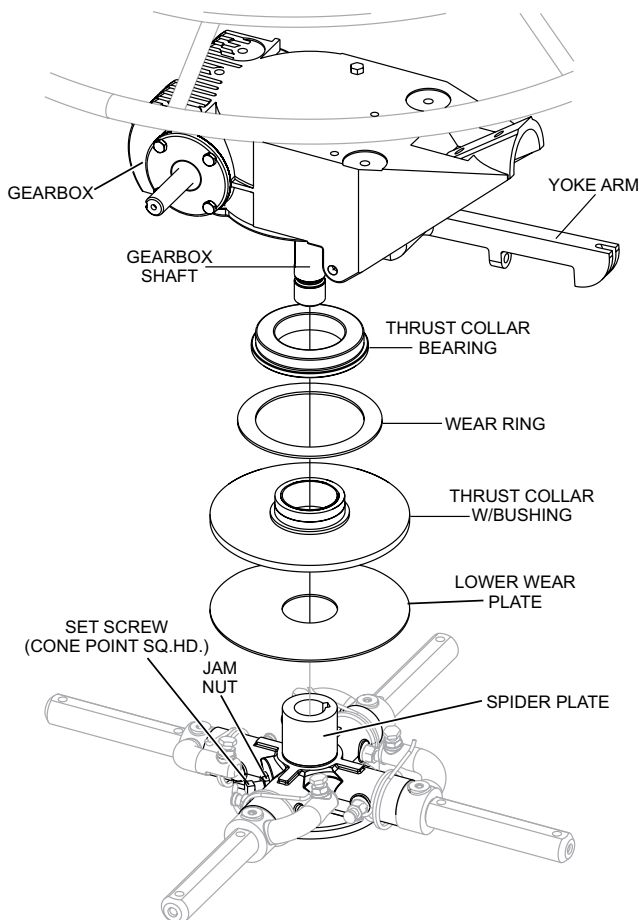

Figure 55. Spider Removal

CHANGING BLADES

It is recommended that **ALL** the blades on the trowel are changed at the same time. If only one or some of the blades are changed, the machine will not finish concrete consistently and the machine may wobble or bounce.

Perform the following procedure when changing blades: Please note the blade orientation on the trowel arm before removing.

1. Lift the trowel up, placing blocks under the main guard ring to support it.
2. Remove the bolts and lock washers from all the trowel arms, and then remove the blades as shown in Figure 56.

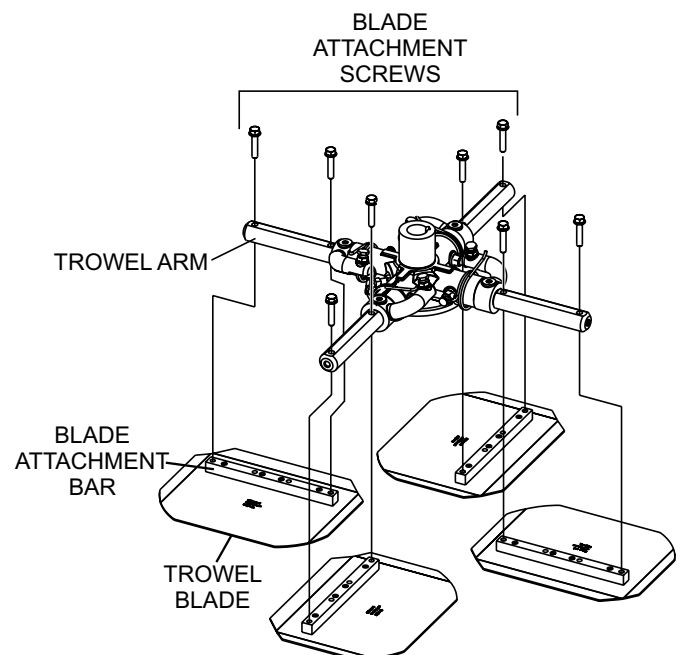

Figure 56. Blade Removal

3. Wire brush and remove all concrete and debris from all six sides of each of the four trowel arms. This is important to properly seat the new blades.
4. Install the new blades, maintaining the proper blade orientation for direction of rotation.
5. Reinstall the bolts and lock washers.

TROWEL ARM REMOVAL

1. Each trowel arm is held in place at the spider plate by a hex head bolt (zerk grease fitting) and a roll pin. Remove both the hex head bolt and the roll pin (Figure 57) from the spider plate.
2. Remove the trowel arm from the spider plate.
3. Should the trowel arm inserts (bushing) come out with the trowel arm, remove the bushing from the trowel arm and set aside in a safe place. If the bushing is retained inside the spider plate, carefully remove the bushing
4. Examine the trowel arm bushing insert (Figure 57), clean if necessary. Replace bushing if out of round or worn.

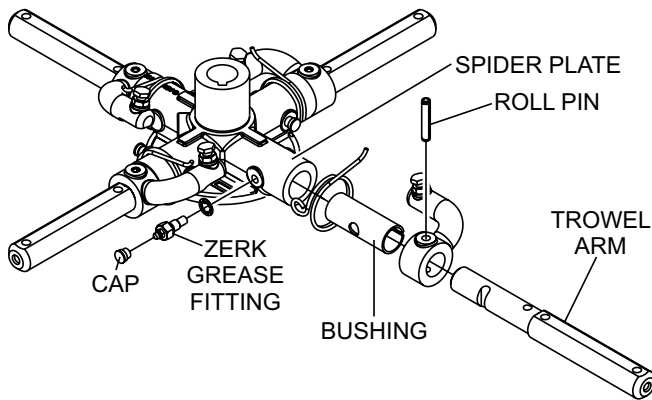

Figure 57. Trowel Arm Removal

CHECKING TROWEL ARM STRAIGHTNESS

Trowel arms (Figure 58) can be damaged by rough handling, such as dropping the trowel on the pad, or by striking exposed plumbing, forms, or rebar while in operation. A bent trowel arm will not allow the trowel to operate in a smooth fluid rotation. If bent trowel arms are suspect, check for flatness as follows:

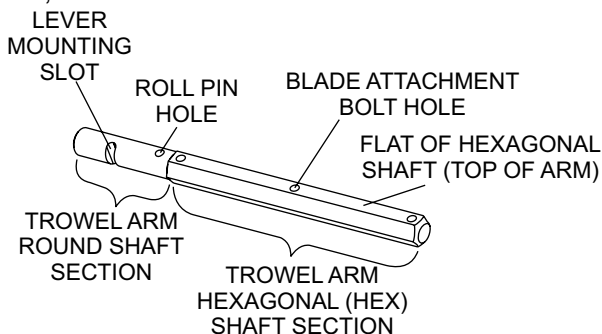

Figure 58. Trowel Arm

1. Use a thick steel plate, granite slab or any surface which is true and flat, to check all six sides of each trowel arm for flatness (Figure 59).
2. Check each of the six sides of the trowel arm (hex section). A feeler gauge of .004 inch (0.10 mm) should not pass between the flat of the trowel arm and the test surface along its length on the test surface.

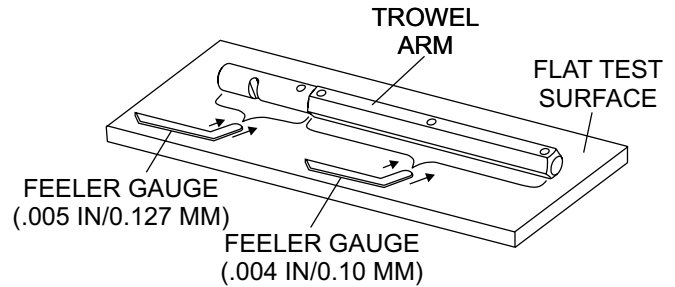

Figure 59. Checking Trowel Arm Flatness

3. Next, check the clearance between the round shaft and the test surface as one of the flat hex sections of the arm rests on the test surface. Rotate the arm to each of the flat hex sections and check the clearance of the round shaft. Use a feeler gauge (Figure 60) of .005 inch (0.127 mm). Each section should have the same clearance between the round of the trowel arm shaft and the test surface.
4. If the trowel arm is found to be uneven or bent, replace the trowel arm.

TROWEL ARM LEVER ADJUSTMENT

The easiest and most consistent way to adjust the trowel arm lever is to use the Trowel Arm Adjustment Fixture (P.N. 1817).

As each trowel arm is locked into the fixture, the arm bolt is adjusted to where it contacts a stop on the fixture. This will consistently adjust all of the trowel arms, keeping the finisher as flat and evenly pitched as possible.

This fixture will allow consistent adjustment of the trowel arm lever. It comes with all the hardware necessary to properly accomplish this maintenance and instructions on how to properly utilize this tool. Adjusting the trowel arm lever without a fixture requires a special talent.

Perform the following procedure when adjusting the trowel arm lever:

1. Unscrew the locking bolts on the adjustment fixture and place the trowel arm (lever attached) into the fixture channel as shown in Figure 60.
2. Ensure the fixture arm is in the up position.
3. A thin shim may be required to cover the blade holes on the trowel arm. Make sure to align the trowel adjustment bolt with the fixture adjustment bolt.

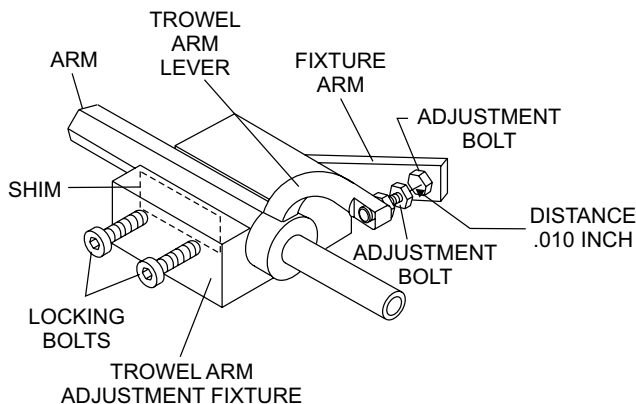

Figure 60. Trowel Arm Adjustment Fixture

4. Use an allen wrench to tighten the locking bolts securing the trowel arm in place.
5. Adjust the bolt distance shown in Figure 60 to match one of the arms. The other arms will be adjusted to match this distance.

6. Loosen the locking nut on the trowel arm lever, then turn the trowel arm adjusting bolt until it barely touches (.010") the fixture adjusting bolt.
7. Once the correct adjustment is made, tighten the lock nut on the trowel arm to lock in place.
8. Loosen locking nuts on the adjustment fixture, and remove trowel arm.
9. Repeat steps for the remaining trowel arms.

REASSEMBLY

1. Clean and examine the upper/lower wear plates and thrust collar. Examine the entire spider assembly. Wire brush any concrete or rust buildup. If any of the spider components are found to be damaged or out of round, replace them.
2. Make sure that the bronze trowel arm bushing is not damage or out of round. Clean the bushing if necessary. If the bronze bushing is damaged or worn, replace it.
3. Reinstall bronze bushing onto trowel arm.
4. Repeat steps 2 -3 for each trowel arm.
5. Make sure that the spring tensioner is in the correct position to exert tension on the trowel arm.
6. Insert all trowel arms with levers into spider plate (with bronze bushing already installed) using care to align grease hole on bronze bushing with grease hole fitting on spider plate.
7. Lock trowel arms in place by tightening the hex head bolt with zerk grease fitting and jam nut.
8. Reinstall the blades onto the trowel arms.
9. Install stabilizer ring onto spider assembly.
10. Reinstall lower wear plate, thrust collar and upper wear ring in the reverse order that they were disassembled onto the spider shaft. Make sure that there is little or no lateral movement between the thrust collar and the spider shaft.
11. Carefully lift the upper trowel assembly, line up the keyway on gear box main shaft and insert into spider assembly.

12. Reinstall square head cone point into spider plate and tighten in place. Tighten jam nut. Use care in making sure point of set screw engages groove in gear box main shaft.
13. Lubricate all grease points (zerk fittings) with premium "Lithum 12" based grease, conforming to NLGI Grade #2 consistency.

INSTALLING PANS ONTO FINISHER BLADES

These round discs, sometimes referred to as "pans", attach to the spiders arms and allow early floating on wet concrete and easy movement from wet to dry areas. They are also very effective in embedding large aggregates and surface hardeners.

Refer to Figure 61 when installing pans onto finisher blades.

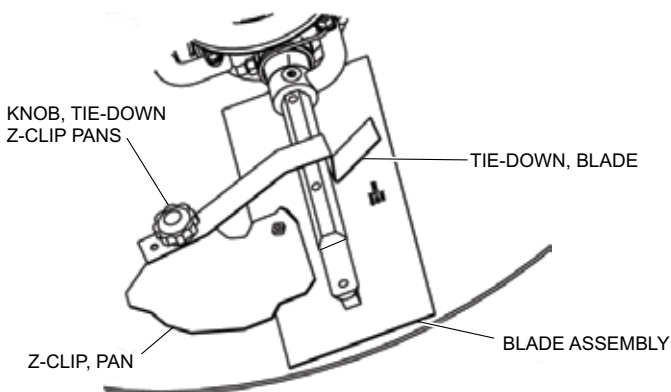

Figure 61. Z-Clip Finisher Pan Installation

1. Lift trowel just enough to slide pan under blades. Lower finisher onto pan with blades adjacent to Z-Clips.
2. Rotate blades into position under Z-Clips. Ensure that the blades are rotated in the direction of travel when the machine is in operation or use the engine to rotate the blades into position.
3. Attach the blade tie-downs to the far side of the Z-Clip brackets with tie-down knobs as shown in Figure 61.
4. Check to make certain that the blade edges are secured under the Z-Clips and the tie-downs are secured completely over the edges of the blade bar before the machine is put back into operation.

LONG-TERM STORAGE

For storage of the trowel for over 30 days, the following is required:

- Drain the fuel tank completely, or add STA-BIL to the fuel.
- Run the engine until the gasoline in the carburetor is completely consumed.
- Completely drain the oil from the crankcase and refill with fresh oil.
- Remove the spark plug. Pour 5 to 10 cc of SAE 30 oil into the cylinder. Turn the engine switch to the **START** position for a few seconds to distribute the oil. Reinstall the spark plug.
- Clean all external parts of the trowel with a cloth.
- Cover the trowel and store in a clean, dry place.

TROUBLESHOOTING

Troubleshooting (Engine)		
Symptom	Possible Problem	Solution
Difficult to start, fuel is available, but no spark at spark plug.	Spark plug bridging?	Check gap, insulation or replace spark plug.
	Carbon deposit on spark plug?	Clean or replace spark plug.
	Short circuit due to deficient spark plug insulation?	Check spark plug insulation, replace if worn.
	Improper spark plug gap?	Set to proper gap.
	Fuel reaching carburetor?	Check fuel line.
	Water in fuel tank?	Flush or replace fuel tank.
	Fuel filter clogged?	Replace fuel filter.
	Stuck carburetor?	Check float mechanism.
	Spark plug is red?	Check transistor ignition unit.
	Spark plug is bluish white?	If insufficient compression, repair or replace engine. If injected air leaking, correct leak. If carburetor jets clogged, clean carburetor.
	No spark present at tip of spark plug?	Check transistor ignition unit is broken, and replace defective unit. Check if voltage cord cracked or broken and replace. Check if spark plug if fouled and replace.
	No oil?	Add oil as required.
	Oil pressure alarm lamp blinks upon starting? (if applicable)	Check automatic shutdown circuit, "oil sensor". (if applicable)
Difficult to start, fuel is available, and spark is present at the spark plug.	ON/OFF switch is shorted?	Check switch wiring, replace switch.
	Ignition coil defective?	Replace ignition coil.
	Improper spark gap, points dirty?	Set correct spark gap and clean points.
	Condenser insulation worn or short circuiting?	Replace condenser.
	Spark plug wire broken or short circuiting?	Replace defective spark plug wiring.
Difficult to start, fuel is available, spark is present and compression is normal.	Wrong fuel type?	Flush fuel system, and replace with correct type of fuel.
	Water or dust in fuel system?	Flush fuel system.
	Air cleaner dirty?	Clean or replace air cleaner.
	Choke open?	Close choke.
Difficult to start, fuel is available, spark is present and compression is low.	Suction/exhaust valve stuck or protruded?	Reseat valves.
	Piston ring and/or cylinder worn?	Replace piston rings and/or piston.
	Cylinder head and/or spark plug not tightened properly?	Torque cylinder head bolts and spark plug.
	Head gasket and/or spark plug gasket damaged?	Replace head and spark plug gaskets.
No fuel present at carburetor.	No fuel in fuel tank?	Fill with correct type of fuel.
	Fuel cock does not open properly?	Apply lubricant to loosen fuel cock lever, replace if necessary.
	Fuel filter/lines clogged?	Replace fuel filter.
	Fuel tank cap breather hole clogged?	Clean or replace fuel tank cap.
	Air in fuel line?	Bleed fuel line.

TROUBLESHOOTING

Troubleshooting (Engine) - continued		
Symptom	Possible Problem	Solution
Weak in power, compression is proper and does not misfire.	Air cleaner dirty?	Clean or replace air cleaner.
	Improper level in carburetor?	Check float adjustment, rebuild carburetor.
	Defective spark plug?	Clean or replace spark plug.
	Improper spark plug?	Set to proper gap.
Weak in power, compression is proper but misfires.	Water in fuel system?	Flush fuel system and replace with correct type of fuel.
	Dirty spark plug?	Clean or replace spark plug.
	Ignition coil defective?	Replace ignition coil.
Engine overheats.	Spark plug heat value incorrect?	Replace with correct type of spark plug.
	Wrong type of fuel?	Replace with correct type of fuel.
	Cooling fins dirty?	Clean cooling fins.
	Intake air restricted?	Clear intake of dirt and debris. Replace air cleaner elements as necessary.
	Oil level too low or too high?	Adjust oil to proper level.
Rotational speed fluctuates.	Governor adjusted incorrectly?	Adjust governor.
	Governor spring defective?	Replace governor spring.
	Fuel flow restricted?	Check entire fuel system for leaks or clogs.
Recoil starter malfunctions. (if applicable)	Recoil mechanism clogged with dust and dirt?	Clean recoil assembly with soap and water.
	Spiral spring loose?	Replace spiral spring.
Starter malfunctions.	Loose, damaged wiring?	Ensure tight, clean connections on battery and starter.
	Battery insufficiently charged?	Recharge or replace battery.
	Starter damaged or internally shorted?	Replace starter.
Burns too much fuel.	Over-accumulation of exhaust products?	Check and clean valves. Check muffler and replace if necessary.
	Wrong spark plug?	Replace spark plug with manufacturer's suggested type.
Exhaust color is continuously "white".	Lubricating oil is wrong viscosity?	Replace lubricating oil with correct viscosity.
	Worn rings?	Replace rings.
Exhaust color is continuously "black".	Air cleaner clogged?	Clean or replace air cleaner.
	Choke valve set to incorrect position?	Adjust choke valve to correct position.
	Carburetor defective, seal on carburetor broken?	Replace carburetor or seal.
	Poor carburetor adjustment, engine runs too rich?	Adjust carburetor.
Will not start, no power with ON/OFF switch in "ON" position.	ON/OFF switch not activated ON?	Turn on ON/OFF Switch.
	ON/OFF switch/wiring defective?	Replace ON/OFF switch. Check wiring.
	Centrifugal stop switch not activated ON?	Turn on centrifugal stop switch.
	Centrifugal stop switch/wiring defective?	Replace centrifugal stop switch. Check wiring.

TROUBLESHOOTING

Troubleshooting (Walk-Behind Trowel)		
Symptom	Possible Problem	Solution
Engine running rough or not at all.	Engine ON/OFF Switch in "OFF" position or malfunctioning?	Make sure that the Engine ON/OFF Switch is ON or replace switch if necessary.
	Centrifugal ON/OFF Switch in "OFF" position or malfunctioning?	Place centrifugal stop switch in "ON" position. Check wiring. Replace switch if necessary.
	Fuel?	Look at the fuel system. Make sure there is fuel being supplied to the engine. Check to ensure that the fuel filter is not clogged.
	Ignition?	Check to ensure that the ignition switch has power and is functioning correctly.
	Loose wire connections	Check wiring. Replace or repair as necessary.
	Bad contacts in ON/OFF switch?	Replace ON/OFF switch.
Trowel bounces, rolls concrete, or makes uneven swirls in concrete.	Blades?	Make certain blades are in good condition, not excessively worn. Finish blades should measure no less than 2" (50mm) from the blade bar to the trailing edge, combo blades should measure no less than 3.5" (89mm). Trailing edge of blade should be straight and parallel to the blade bar.
	Pitch adjustment?	Check that all blades are set at the same pitch angle as measured at the spider. A field adjustment tool is available for height adjustment of the trowel arms. (Contact Parts Dept.)
	Bent trowel arms?	Check the spider assembly for bent trowel arms. If one of the arms is even slightly bent, replace it immediately.
	Spider?	Check fit of arms in spider. This can be done by moving the trowel arms up and down. If there is more than 1/8 inch (3.2 mm) of travel at the tip of the arm, the spider and arms should be replaced.
	Thrust collar?	Check the flatness of the thrust collar by rotating it on the spider. If it varies by more than 0.02 inch (0.5 mm) replace the thrust collar.
	Thrust collar bushing?	Check the thrust collar by rocking it on the spider. If it can tilt more than 3/32 inch (2.4 mm) - as measured at the thrust collar O.D., replace the thrust collar.
	Thrust bearing worn?	Check the thrust bearing to see that it is spinning freely. Replace if necessary.

TROUBLESHOOTING

Troubleshooting (Walk-Behind Trowel) - continued		
Symptom	Possible Problem	Solution
Machine has a perceptible rolling motion while running.	Main shaft?	The main output shaft of the gearbox assembly should be checked for straightness. The main shaft must run straight and cannot be more than 0.003" (0.08 mm) out of round at the spider attachment point.
	Yoke?	Check to make sure that both fingers of the yoke press evenly on the wear cap. Replace yoke as necessary.
	Blade Pitch?	Check to ensure that each blade is adjusted to have the same pitch as all other blades. Adjust per maintenance section in manual.
Clutch slipping or sluggish response to engine speed change.	Worn V-belts?	Replace V-belt.
	Hand clutch out of adjustment?	Adjust per instructions in maintenance section of this manual.
	Worn or defective hand clutch parts?	Replace parts as necessary.
	Worn bearings in gearbox?	Rotate input shaft by hand. If shaft rotates with difficulty, check the input and output shaft bearings. Replace as necessary.
	Worn or broken gears in gearbox?	Verify that the gearbox shaft rotates when the input shaft is rotated. Replace both the worm and worm gear as a set.
Trowel blades do not rotate.	Defective clutch?	Replace clutch.
	Broken V-belt?	Replace V-belt.
	Defective ON/OFF switch?	Check and replace ON/OFF switch if necessary.
	Defective centrifugal ON/OFF switch?	Check and replace centrifugal ON/OFF switch if necessary.

WIRING DIAGRAM

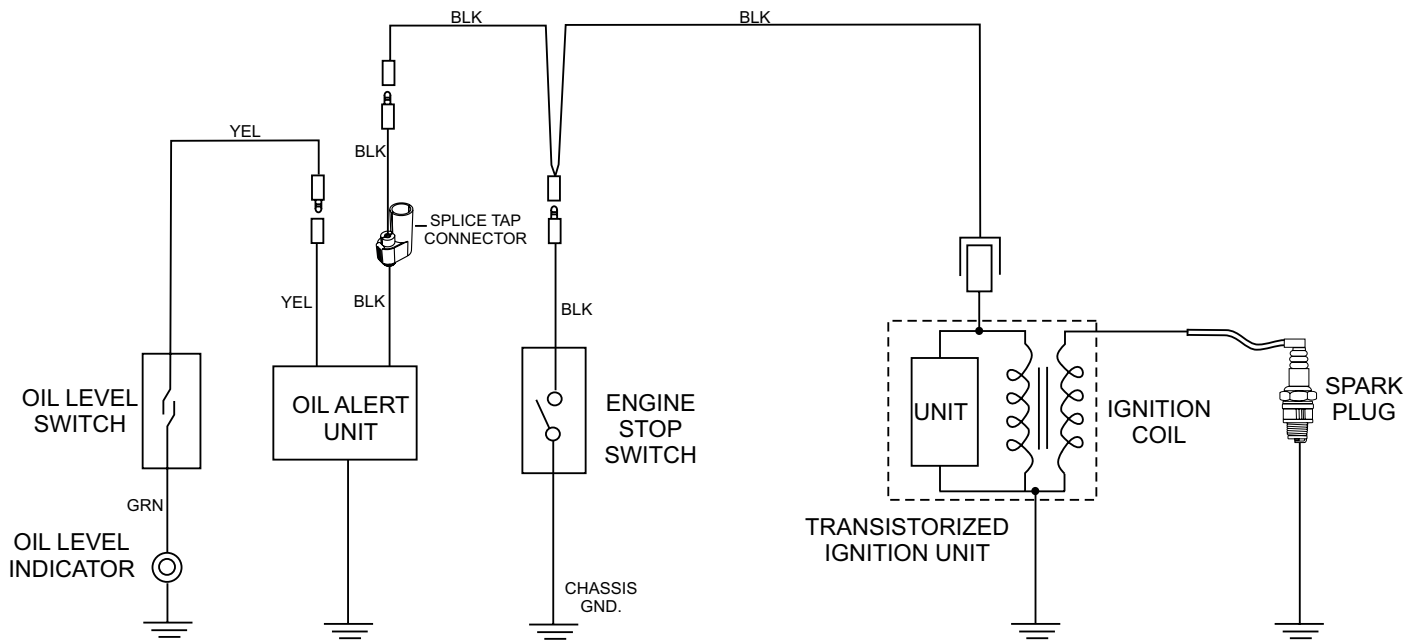
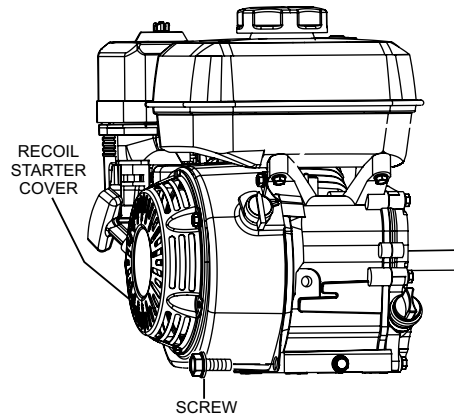

EXPLANATION OF CODE IN REMARKS COLUMN

The following section explains the different symbols and remarks used in the Parts section of this manual. Use the help numbers found on the back page of the manual if there are any questions.

NOTICE

The contents and part numbers listed in the parts section are subject to change **without notice**. Multiquip does not guarantee the availability of the parts listed.

SAMPLE PARTS LIST

NO.	PART NO.	PART NAME	QTY.	REMARKS
1	12345	BOLT	1	INCLUDES ITEMS W/%
2%		WASHER, 1/4 IN.		NOT SOLD SEPARATELY
2%	12347	WASHER, 3/8 IN. ...	1	MQ-45T ONLY
3	12348	HOSE	A/R	MAKE LOCALLY
4	12349	BEARING	1	S/N 2345B AND ABOVE

NO. Column

Unique Symbols — All items with same unique symbol (@, #, +, %, or >) in the number column belong to the same assembly or kit, which is indicated by a note in the “Remarks” column.

Duplicate Item Numbers — Duplicate numbers indicate multiple part numbers, which are in effect for the same general item, such as different size saw blade guards in use or a part that has been updated on newer versions of the same machine.

NOTICE

When ordering a part that has more than one item number listed, check the remarks column for help in determining the proper part to order.

PART NO. Column

Numbers Used — Part numbers can be indicated by a number, a blank entry, or TBD.

TBD (To Be Determined) is generally used to show a part that has not been assigned a formal part number at the time of publication.

A blank entry generally indicates that the item is not sold separately or is not sold by Multiquip. Other entries will be clarified in the “Remarks” Column.

QTY. Column

Numbers Used — Item quantity can be indicated by a number, a blank entry, or A/R.

A/R (As Required) is generally used for hoses or other parts that are sold in bulk and cut to length.

A blank entry generally indicates that the item is not sold separately. Other entries will be clarified in the “Remarks” Column.

REMARKS Column

Some of the most common notes found in the “Remarks” Column are listed below. Other additional notes needed to describe the item can also be shown.

Assembly/Kit — All items on the parts list with the same unique symbol will be included when this item is purchased.

Indicated by:

“INCLUDES ITEMS W/(unique symbol)”

Serial Number Break — Used to list an effective serial number range where a particular part is used.

Indicated by:

“S/N XXXXX AND BELOW”

“S/N XXXX AND ABOVE”

“S/N XXXX TO S/N XXX”

Specific Model Number Use — Indicates that the part is used only with the specific model number or model number variant listed. It can also be used to show a part is NOT used on a specific model or model number variant.

Indicated by:

“XXXXX ONLY”

“NOT USED ON XXXX”

“Make/Obtain Locally” — Indicates that the part can be purchased at any hardware shop or made out of available items. Examples include battery cables, shims, and certain washers and nuts.

“Not Sold Separately” — Indicates that an item cannot be purchased as a separate item and is either part of an assembly/kit that can be purchased, or is not available for sale through Multiquip.

SUGGESTED SPARE PARTS

JH90C WALK-BEHIND TROWEL

1 to 3 Units

Qty.	P/N	Description
1.....	21172.....	CABLE, THROTTLE
1.....	20285.....	CABLE, CONTROL, (STD)
1.....	20297.....	CABLE, CONTROL, (Q.P.)
1.....	30230.....	CABLE, INSTACLUTCH
2.....	1243.....	V-BELT, A27
4.....	1157 A.....	BUSHING, TROWEL ARM
4.....	2826-1.....	ARM, TROWEL, 9-3/4"
1.....	10968.....	THRUST BEARING KIT
2.....	20111.....	OIL, MOBIL SYNTHETIC 22OZ.

HONDA GX270UT2QA2 ENGINE

Qty.	P/N	Description
3.....	17210ZE2515.....	ELEMENT, AIR CLEANER
3.....	9807956846.....	SPARK PLUG, BPR6ES
1.....	28462ZE2W11.....	ROPE, RECOIL STARTER
1.....	17620Z4H030.....	CAP, FUEL TANK
1.....	17672Z4H000.....	FUEL, FILTER

NOTICE

Part numbers on this Suggested Spare Parts list may supersede/replace the part numbers shown in the following parts lists.

NAMEPLATES AND DECALS

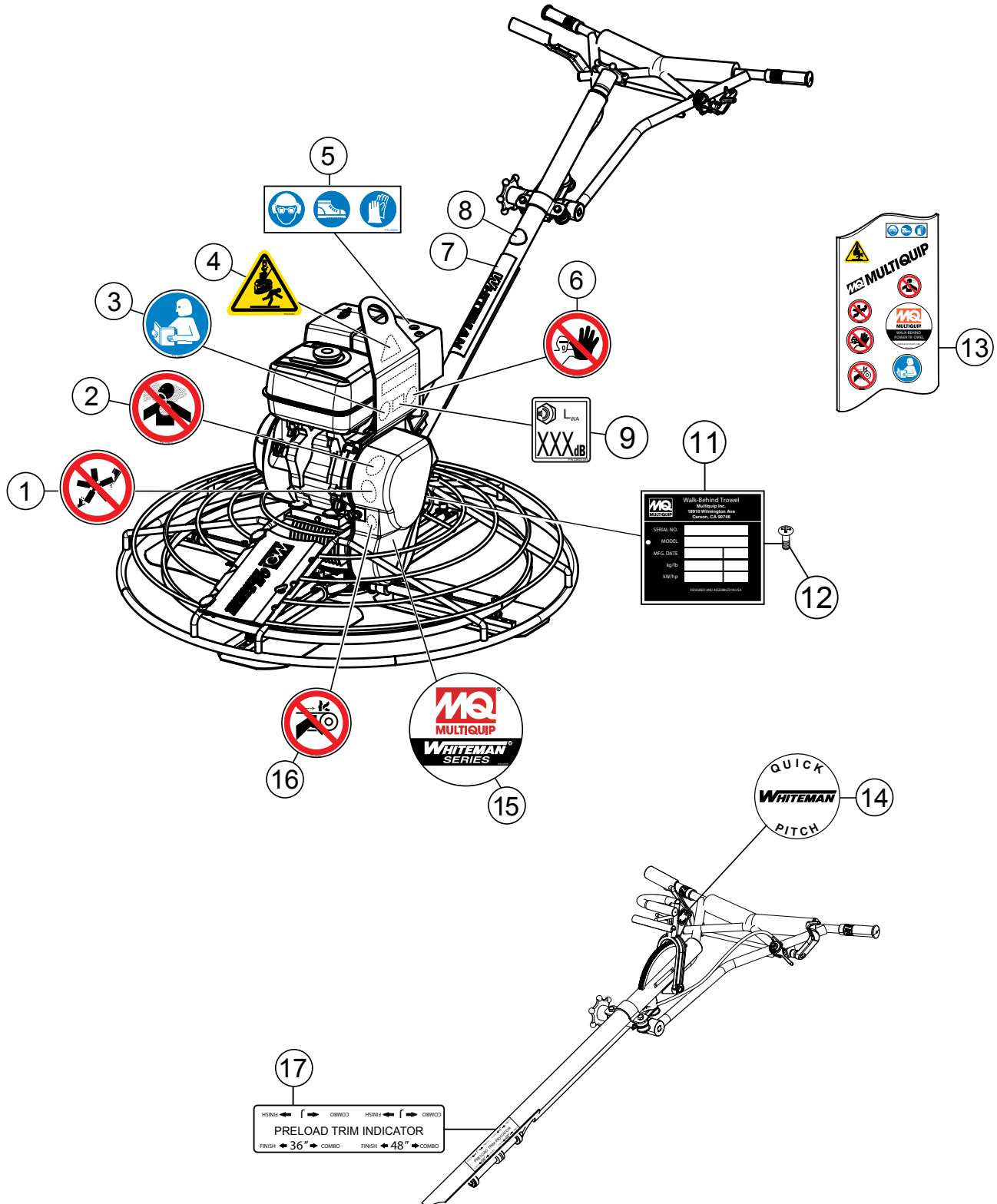

NAMEPLATES AND DECALS

<u>NO.</u>	<u>PART NO.</u>	<u>PART NAME</u>	<u>QTY.</u>	<u>REMARKS</u>
1#	23698	ISO DECAL: ROTATING BLADE HAZARD, 2.00" DIA.	1	
2#	23810	ISO DECAL: INHALATION HAZARD, 2.00" DIA	1	
3#	23699	ISO DECAL: READ MANUAL, 2.00" DIA.	1	
4#	23700	ISO DECAL: LIFTING/CRUSH, 2.4" X 2.0"	1	
5#	36099	ISO DECAL: PROTECTIVE CLOTHING, 3.50" X 1.13"	1	
6#	23701	ISO DECAL: ASK FOR TRAINING, 2.00" DIA.	1	
7	2942	DECAL: MQ WHITEMAN 13" WHITE	1	
8	1492	DECAL: FINISHER HANDLE	1	
9	23803-111	ISO DECAL: GUARANTEED SOUND 111 dbA	1	
10#	20816	DECAL: MQ LOGO 6.78" X .80"	2	
11		DECAL: SERIAL PLATE	1.....	CONTACTMQPARTS DEPT.
12	4014	SCREW, 2-3/16 P-K TYPE U-DRIVE	2	
13	30319	DECAL KIT	1.....	INCLUDES ITEMS W/#
14	12405	DECAL: WHITEMAN QUICK PITCH	1	
15#	22070	DECAL: MQ WHITEMAN POWER TROWEL, ROUND	1	
16#	23704	ISO DECAL: GUARD WARNING 2.00" DIA.	1	
17	1735	DECAL: PRELOAD TRIM INDICATOR	1	

STANDARD HANDLE ASSY.

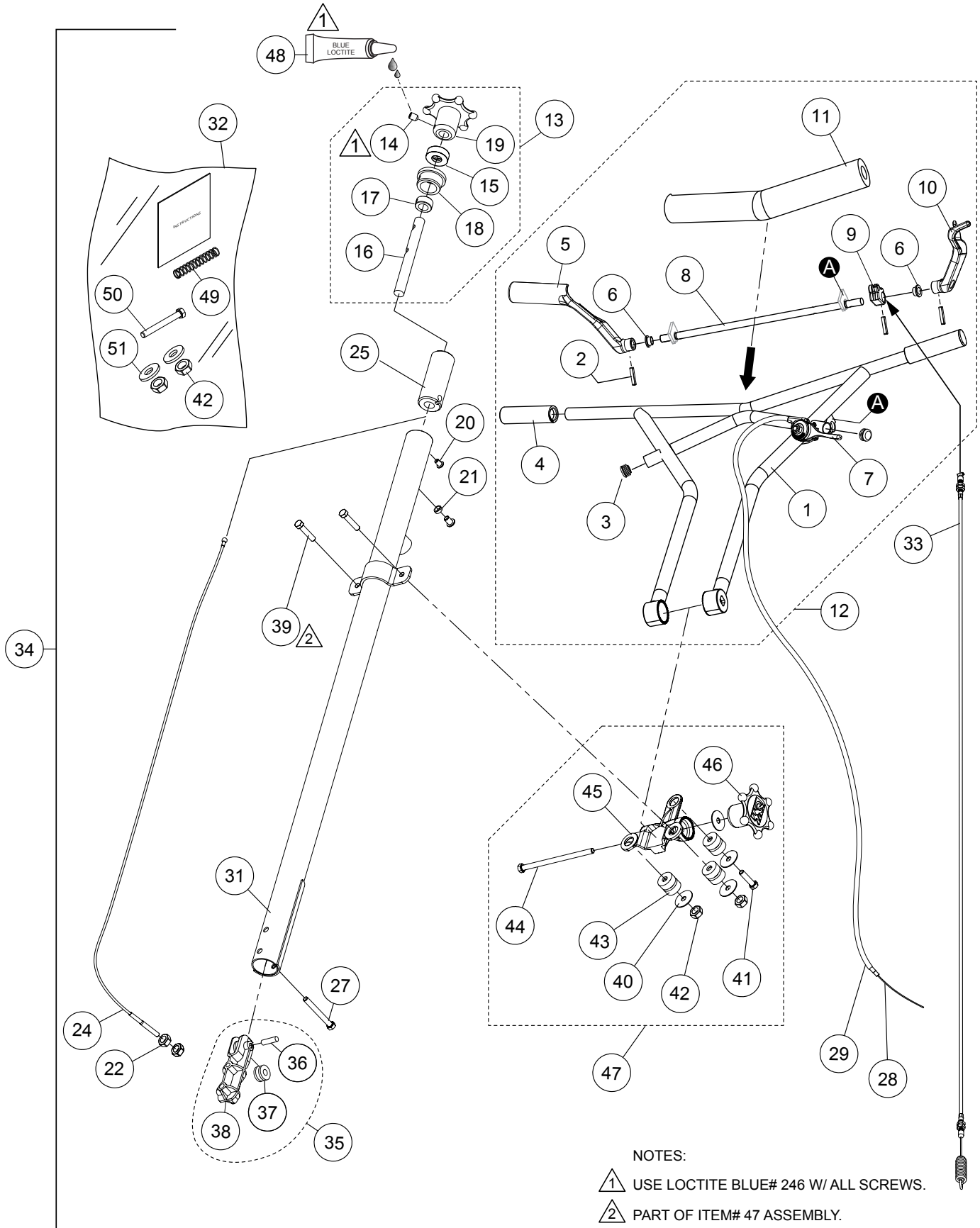

STANDARD HANDLE ASSY.

<u>NO.</u>	<u>PART NO.</u>	<u>PART NAME</u>	<u>QTY.</u>	<u>REMARKS</u>
1#%	30155	UPPER HANDLE	1	
2#%	30203	PIN, ROLL, 3/16" X 7/8"	3	
3#%	22208	PLUG, THROTTLE LEVER	2	
4#%	30174	GRIP	2	
5#%	30169	CASTING, RIGHT PADDLE	1	
6#%	30173	BUSHING, FLANGED	2	
7#%	22732	THROTTLE LEVER ASSY.	1	
8#%	30172	ROD, TORSION BAR	1	
9#%	30171	CASTING, CABLE PULL	1	
10#%	30170	CASTING, LEFT PADDLE	1	
11#%	22166	COVER, VIBE CONTROL HANDLE PAD	1	
12#	30156	UPPER HANDLE ASSY.	1	INCLUDES ITEMS W/%
13#	20819	HAND WHEEL ASSY., PITCH CONTROL	1	INCLUDES ITEMS W/\$
14#\$	0122 C	SCREW, SHS 3/8-16 X 1/2"	1	
15#\$	0281	BEARING, THRUST	1	
16#\$	1478	SHAFT, TROWEL CONTROL	1	
17#\$	3615	COLLAR, SET 3/4" ID, W/SET SCREW	1	
18#\$	20282	BEARING, TROWEL CONTROL	1	
19#\$	20817	WHEEL, HAND PITCH CONTROL	1	
20#	0786	SCREW, BHC 1/4-20 X 3/8" NYL PATCH, NP	2	
21#	0786 A	SPACER, SLIDE BLOCK GUIDE	1	
22#	1116	NUT, BRASS JAM 5/16-18	2	
24#	20285	CABLE, CONTROL	1	
25#	20287	SLIDE BLOCK, TROWEL CONTROL	1	
27#	21017	SCREW, HHC 3/8-16 X 3-1/4" FULL THRD GRD5	1	
28#	21172	CABLE, THROTTLE	1	
29#	21173	HOUSING, THROTTLE CABLE	1	
31#	22095-P	HANDLE, W/ FIN VIBE CONTROL	1	
32#	30220	KIT, HANDLE INSTALLATION	1	INCLUDES ITEMS W/◆
33#	30230	CABLE, CLUTCH	1	
34	SXHC	MAIN HANDLE ASSY.	1	INCLUDES ITEMS W/#, CONTACT UNIT SALES

STANDARD HANDLE ASSY.

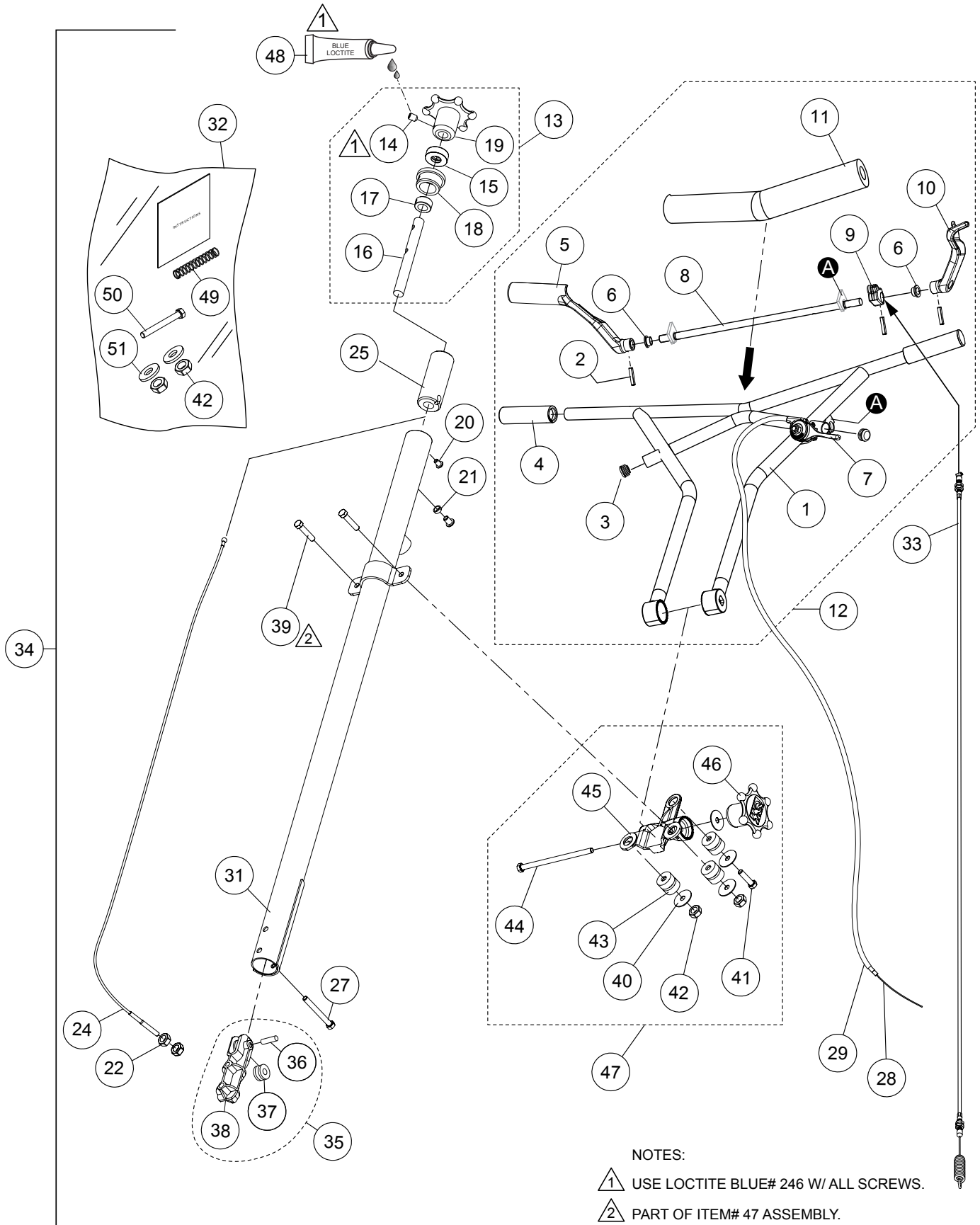

NOTES:

- ▲ 1 USE LOCTITE BLUE# 246 W/ ALL SCREWS.
- ▲ 2 PART OF ITEM# 47 ASSEMBLY.

STANDARD HANDLE ASSY.

NO.	PART NO.	PART NAME	QTY.	REMARKS
35#	20280	BLOCK, PITCH CONTROL	1.....	INCLUDES ITEMS W/@
36#@	20279	PIN, SUPPORT BLOCK	1	
37#@	1118	PULLEY, PITCH CABLE ASSY.	1	
38#@	20275	BLOCK, SUPPORT	1	
39#◇	1665	SCREW, HHC 3/8-16 X 2"	2	
40#◇	3233	WASHER, FENDER, 1-1/2" OD X 3/8" ID	4	
41#◇	9154	SCREW, HHC 3/8-16 X 1-3/4"	1	
42#◇◆	10133	NUT, NYLOC 3/8-16	4	
43#◇	22059	ISOLATOR, VIBRATION	3	
44#◇	22167	SCREW, HHC 3/8-16 X 6-1/2" GRD 5	1	
45#◇	22206	CHASSIS, CAST VIBRATION ISOLATOR	1	
46#◇	20439	WHEEL ASSY., HAND	1	
47#	30206	VIBE CHASSIS ASSY.....	1.....	INCLUDES ITEMS W/◇
48#	60097	LOCTITE, BLUE #246	1	
49#◆	21746	SPRING, PRIMARY THROTTLE RETURN	1	
50#◆	1493	SCREW, HHC 3/8-16 X 3-1/4"	1	
51#◆	10136	WASHER, 3/8" FLAT	2	

QUICK PITCH HANDLE ASSY.

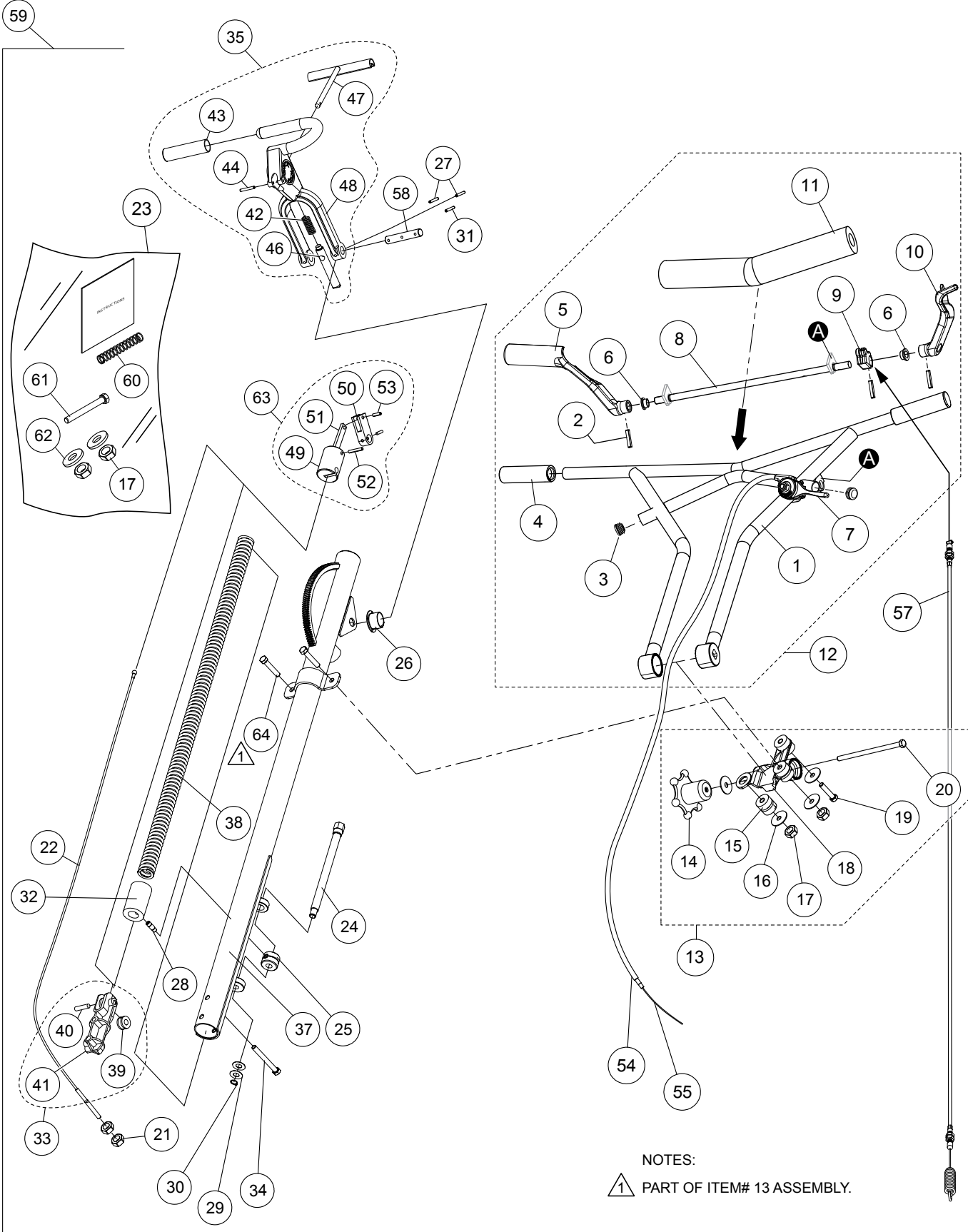

NOTES:
 1 PART OF ITEM# 13 ASSEMBLY.

QUICK PITCH HANDLE ASSY.

NO.	PART NO.	PART NAME	QTY.	REMARKS
1#%	30155	UPPER HANDLE.....	1	
2#%	30203	PIN, ROLL, 3/16" X 7/8".....	3	
3#%	22208	PLUG, THROTTLE LEVER.....	2	
4#%	30174	GRIP.....	2	
5#%	30169	CASTING, RIGHT PADDLE.....	1	
6#%	30173	BUSHING, FLANGED, BRONZE, .51" ID X .625" OD.....	2	
7#%	22732	THROTTLE LEVER ASSY.....	1	
8#%	30172	ROD, TORSION BAR.....	1	
9#%	30171	CASTING, CABLE PULL.....	1	
10#%	30170	CASTING, LEFT PADDLE.....	1	
11#%	22166	COVER, VIBE CONTROL HANDLE PAD.....	1	
12#	30156	UPPER HANDLE ASSY.	1	INCLUDES ITEMS W/%
13#	30206	VIBE CHASSIS ASSY.....	1	INCLUDES ITEMS W/@
14#@	20439	WHEEL ASSY., HAND.....	1	
15#@	22059	ISOLATOR, VIBRATION.....	3	
16#@	3233	WASHER, FENDER, 1.5" OD X 3/8" ID.....	4	
17#@	❖10133	NUT, NYLOC 3/8-16.....	4	
18#@	22206	CHASSIS, CAST VIBRATION ISOLATOR.....	1	
19#@	9154	SCREW, HHC 3/8-16 X 1-3/4".....	1	
20#@	22167	SCREW, HHC 3/8-16 X 6-1/2" GRD 5.....	1	
21#	1116	NUT, BRASS JAM 5/16-18.....	2	
22#	20297	CABLE, CONTROL.....	1	
23#	30220	KIT, HANDLE INSTALLATION.....	1	INCLUDES ITEMS W/❖
24#	1717	SCREW, Q.P. TRIM ADJUSTMENT.....	1	
25#	1718	NUT, Q.P. TRIM CONTROL ADJUSTMENT.....	1	
26#	1719	BUSHING, PIVOT PLATE.....	2	
27#	1729	PIN, ROLL 3/16" X 1-1/4".....	2	
28#	1732	PIN, Q.P. ADJUSTMENT.....	1	
29#	1733	WASHER, 1/2" X 1/32".....	2	
30#	1737	RING, SNAP.....	1	
31#	4568	PIN, ROLL 3/16" X 1".....	1	
32#	20270	Q.P. ADJUSTMENT BLOCK.....	1	
33#	20280	BLOCK, PITCH CONTROL.....	1	INCLUDES ITEMS W/◇
34#	21017	SCREW, HHC 3/8-16 X 3-1/4" FULL THRD GRD5.....	1	
35#	20390	TRIGGER, Q.P. ASSY.....	1	INCLUDES ITEMS W/\$
37#	22060-P	MAIN HANDLE, Q.P. VIBE CONTROL.....	1	
38#	1715	Q.P. SPRING CENTER BALANCE.....	1	
39#◇	1118	PULLEY, PITCH CABLE HANDLE.....	1	
40#◇	20279	PIN, SUPPORT BLOCK 3/8" X 1.59".....	1	
41#◇	20275	BLOCK, SUPPORT.....	1	
42#\$	1706	SPRING, COMPRESSION.....	1	
43#\$	1724	GRIP, HANDLE.....	1	

QUICK PITCH HANDLE ASSY.

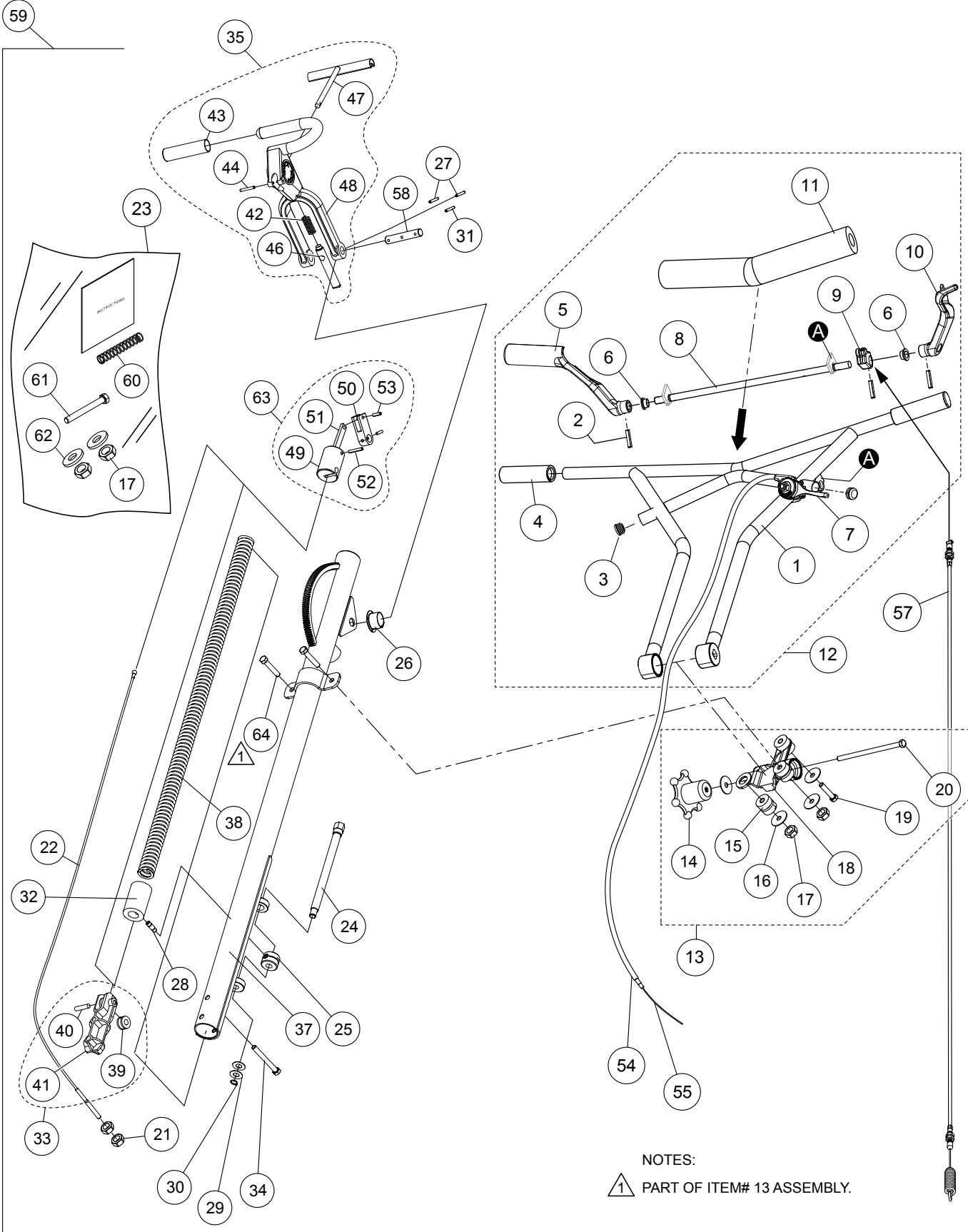

NOTES:
 1 PART OF ITEM# 13 ASSEMBLY.

QUICK PITCH HANDLE ASSY.

<u>NO.</u>	<u>PART NO.</u>	<u>PART NAME</u>	<u>QTY.</u>	<u>REMARKS</u>
44#	\$ 1729	PIN, ROLL 3/16" X 1-1/4"	1	
46#	\$ 20437	PIN, Q.P. LATCH	1	
47#	\$ 1746	TRIGGER, Q.P.	1	
48#	\$ 20389	TRIGGER, QP	1	
49#	◆ 20269	BLOCK, CABLE SLIDE	1	
50#	◆ 20443	ARM, SLIDE CONTROL	1	
51#	◆ 1709	Q.P. DOGBONE	1	
52#	◆ 20276	PIN, ROLL, 1/4" X 1-3/4"	1	
53#	◆ 1731	PIN, ROLL, 1/4" X 3/4"	1	
54#	21173	HOUSING, THROTTLE CABLES	1	
55#	21172	CABLE, THROTTLE	1	
57#	30230	CABLE, INSTACLUTCH, 66.88" L	1	
58#	1711	SHAFT, CONTROL Q.P.	1	
59	QXHC	MAIN HANDLE ASSY, QUICK PITCH.	1	INCLUDES ITEMS W/ CONTACT UNIT SALES
60#	❖ 21746	SPRING, PRIMARY THROTTLE RETURN	1	
61#	❖ 1493	SCREW, HHC 3/8-16 X 3-1/4"	1	
62#	❖ 10136	WASHER, 3/8" FLAT	2	
63#	20293	LINKAGE, QP CONTROL.....	1	INCLUDES ITEMS W/◆
64#	@ 1665	SCREW, HHC 3/8-16 X 2"	2	

GUARD RING AND ENGINE MOUNTING ASSY.

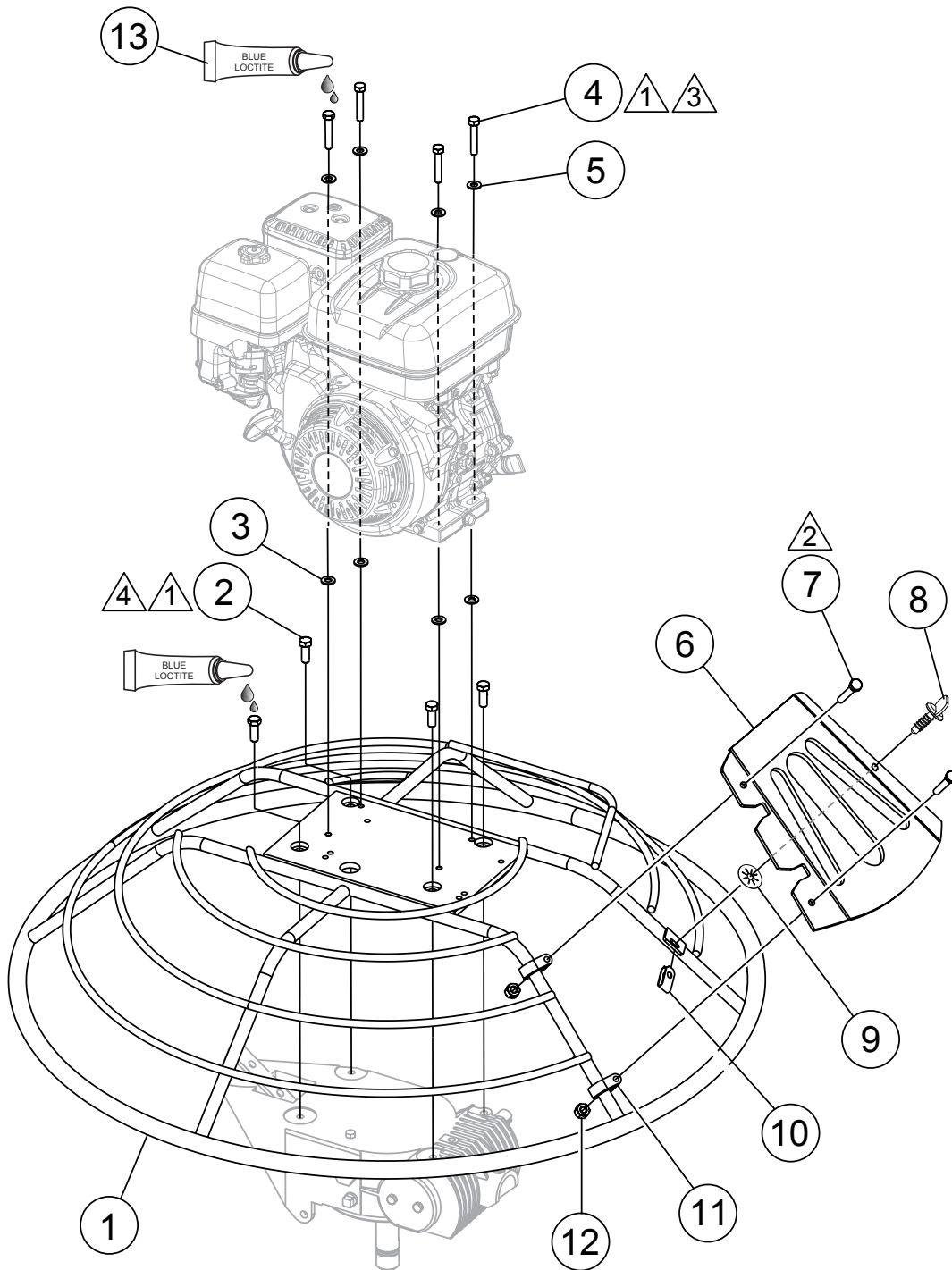

NOTES:

- △1 USE LOCTITE BLUE# 246 W/ ALL SCREWS.
- △2 TORQUE TO 8 FT.-LBS. (10.8 N·m)
- △3 TORQUE TO 14.5 FT.-LBS. (20 N·m)
- △4 TORQUE TO 23 FT.-LBS. (31 N·m)

GUARD RING AND ENGINE MOUNTING ASSY.

<u>NO.</u>	<u>PART NO.</u>	<u>PART NAME</u>	<u>QTY.</u>	<u>REMARKS</u>
1	21965	GUARD RING	1	
2	0205	SCREW, HHC 3/8-16 X 1"	4	
3	13351	WASHER, FLAT 3/8 EXT THICK HIGH STRENGTH	4	
4	1391	SCREW, HHC 5/16-24 X 1-1/2 ZINC	4	
5	933241	WASHER, FLAT SAE 5/16 GRD 9 YZ	4	
6	21880	ACCESS PANEL	1	
7	26250	SCREW, HHC 1/4-20 X 1-3/4"	2	
8	21893	SCREW, FAST LEAD	1	
9	21986	WASHER, FAST LEAD-STAINLESS	1	
10	21894	CLIP, FAST LEAD	1	
11	21922	CLAMP, 0.625" ID PIPE	2	
12	10024	NUT, NYLOC 1/4-20	2	
13	60097	BLUE LOCTITE, #246	AR	

GEARBOX ASSY.

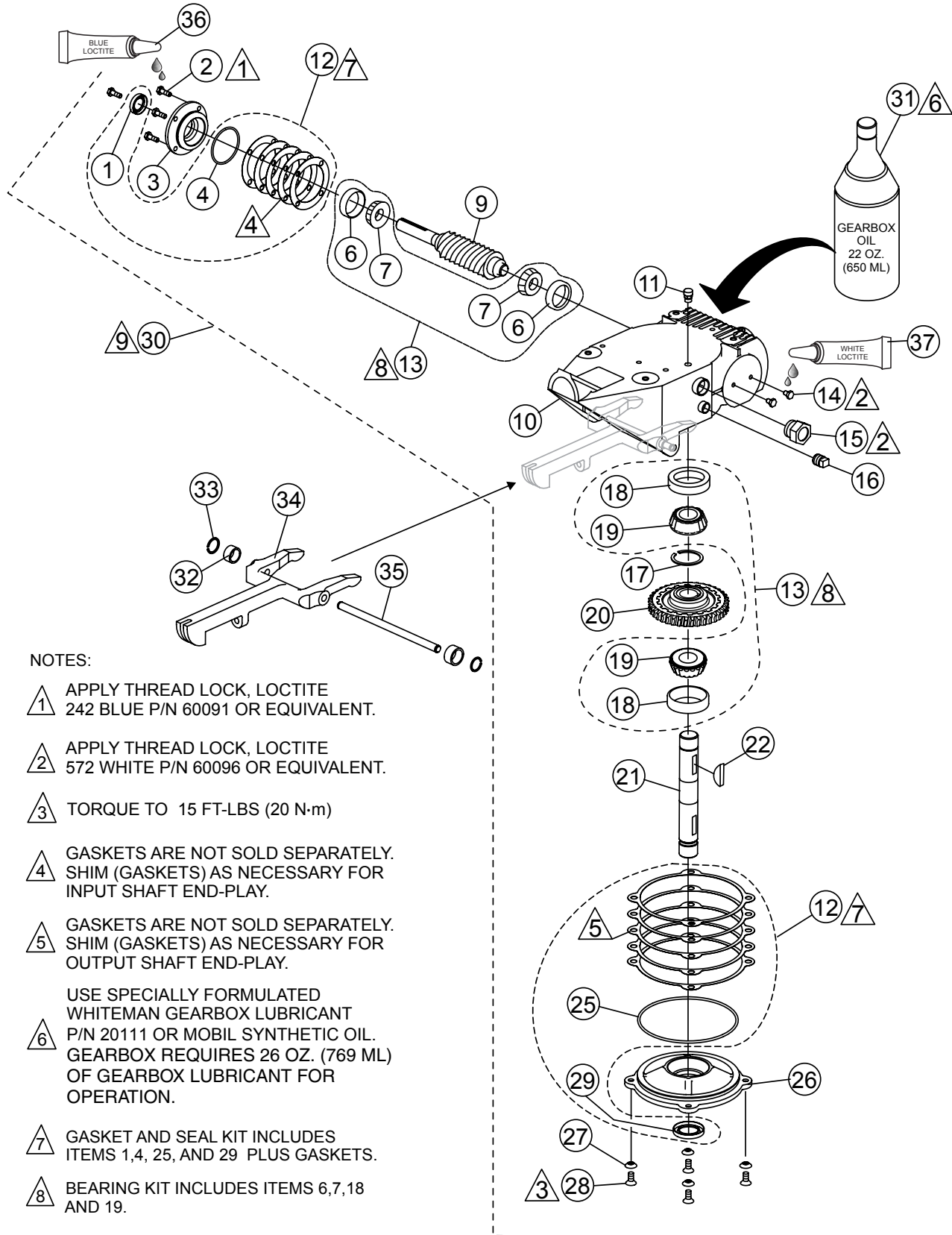

NOTES:

- ▲ 1 APPLY THREAD LOCK, LOCTITE 242 BLUE P/N 60091 OR EQUIVALENT.
- ▲ 2 APPLY THREAD LOCK, LOCTITE 572 WHITE P/N 60096 OR EQUIVALENT.
- ▲ 3 TORQUE TO 15 FT-LBS (20 N·m)
- ▲ 4 GASKETS ARE NOT SOLD SEPARATELY. SHIM (GASKETS) AS NECESSARY FOR INPUT SHAFT END-PLAY.
- ▲ 5 GASKETS ARE NOT SOLD SEPARATELY. SHIM (GASKETS) AS NECESSARY FOR OUTPUT SHAFT END-PLAY.
- ▲ 6 USE SPECIALLY FORMULATED WHITEMAN GEARBOX LUBRICANT P/N 20111 OR MOBIL SYNTHETIC OIL. GEARBOX REQUIRES 26 OZ. (769 ML) OF GEARBOX LUBRICANT FOR OPERATION.
- ▲ 7 GASKET AND SEAL KIT INCLUDES ITEMS 1,4, 25, AND 29 PLUS GASKETS.
- ▲ 8 BEARING KIT INCLUDES ITEMS 6,7,18 AND 19.
- ▲ 9 GEARBOX ASSEMBLY ITEM 30, INCLUDES ITEMS WITHIN DASHED LINE EXCEPT ITEMS 12,13 AND 31.

GEARBOX ASSY.

<u>NO.</u>	<u>PART NO.</u>	<u>PART NAME</u>	<u>QTY.</u>	<u>REMARKS</u>
1%\$	0753	SEAL, OIL.....	1	
2%	0131A	SCREW, HHC 1/4-20 X 3/4"	4	
3%	12876	FLANGE, INPUT SHAFT	1	
4%\$	20395	O-RING, 2".....	1	
6%#	20466	BEARING, CUP, TIMKEN #M11910	2	
7%#	20465	BEARING, CONE, TIMKEN #LM11949.....	2	
9%	1851	GEAR, WORM "B" INPUT SHAFT	1	
10%	12874	CASE, GEAR.....	1	
11%	21218	VENT, AIR.....	1	
12	21046	GASKET/SEAL KIT	1	INCLUDES ITEMS W/\$
13	21047	BEARING KIT	1	INCLUDES ITEMS W/#
14%	20476	SCREW, HHC 1/4-28 X 3/8"	2	
15%	21033	SIGHT GLASS, 3/4 M PIPE STEEL	1	
16%	0121 A	FITTING, PLUG 3/8 MP SQ HEAD	1	
17%	1138	RING, SNAP	1	
18%#	20475	BEARING, CUP TIMKEN #M86610.....	2	
19%#	20474	BEARING, CONE TIMKEN #M86647	2	
20%	1140	GEAR, WORM, COMPOSITE	1	
21%	20470	SHAFT, OUTPUT	1	
22%	1139	KEY, WOODRUFF #810	1	
25%\$	20396	O-RING.....	1	
26%	12875	COVER, GEARBOX.....	1	
27%	10235	WASHER, C/S EXT. SHKP	4	
28%	20875	SCREW, FHSC 5/16-18 X 3/4"	4	
29%\$	0254	SEAL, OIL.....	1	
30	20407	GEARBOX ASSY.	1	INCLUDES ITEMS W/%
31	20111	OIL, MOBIL SYNTHETIC SHC634, 22 OZ. (650 ML)	2	
32	22292	SPACER, 0.5" X 0.402" X .25"L UNTREATED	2	
33	20802	RING, SNAP	2	
34	1150	YOKE ARM	1	
35	20801	PIN, YOKE	1	
36	60091	LOCTITE, BLUE #242	AR	
37	60096	LOCTITE, WHITE #572	AR	

ENGINE AND CLUTCH ASSY.

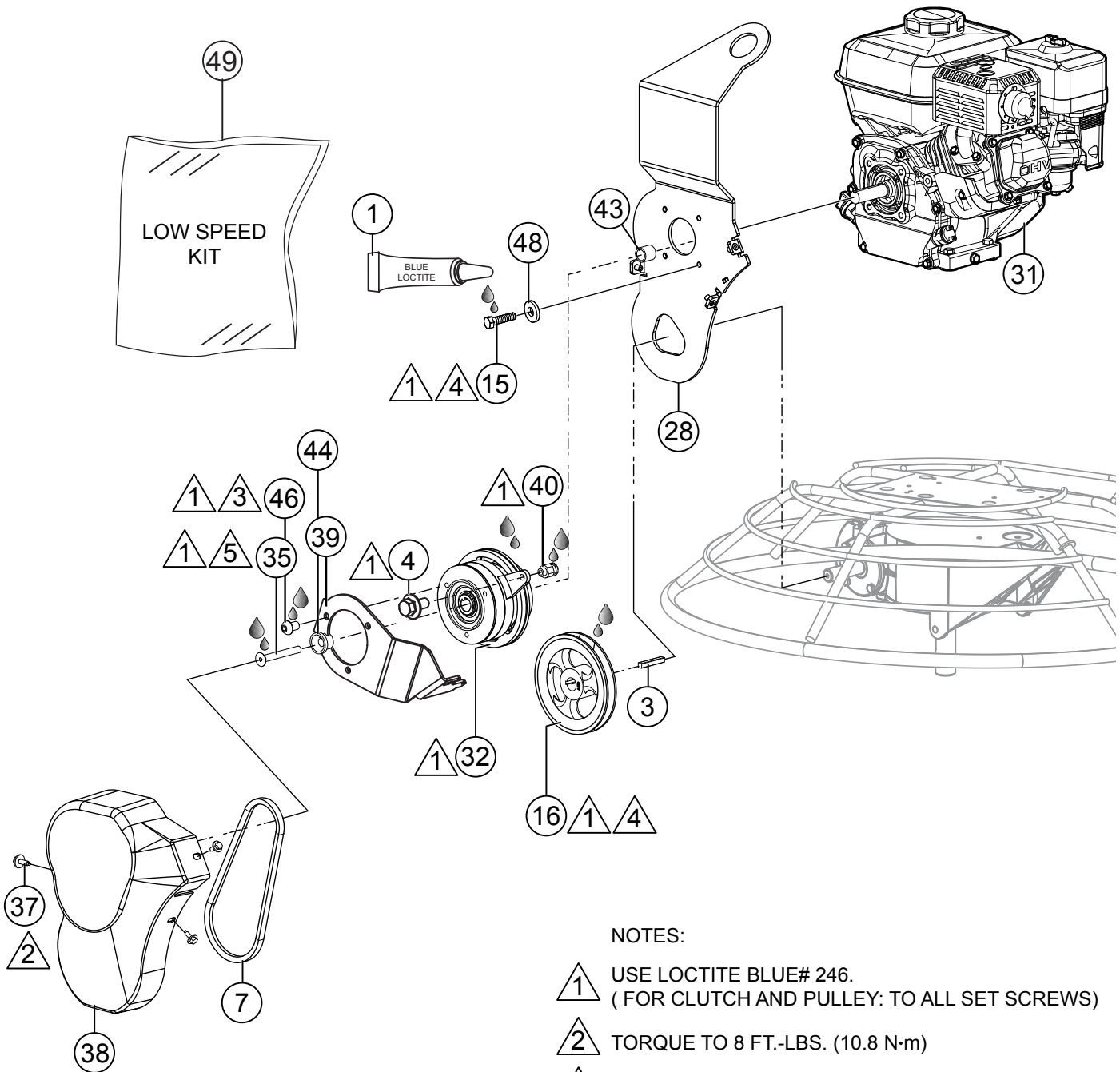

NOTES:

- 1 USE LOCTITE BLUE# 246.
(FOR CLUTCH AND PULLEY: TO ALL SET SCREWS)
- 2 TORQUE TO 8 FT.-LBS. (10.8 N·m)
- 3 TORQUE TO 13 FT.-LBS. (18 N·m)
- 4 TORQUE TO 14.5 FT.-LBS. (19.6 N·m)
- 5 TORQUE TO 42 FT.-LBS. (57 N·m)

ENGINE AND CLUTCH ASSY.

<u>NO.</u>	<u>PART NO.</u>	<u>PART NAME</u>	<u>QTY.</u>	<u>REMARKS</u>
1	60097	BLUE LOCTITE, #246	AR	
3	0627	KEY, 3/16" X 1-1/4"	1	
4	22538-001	SCREW, HEX FLANGE, 1/4-20 X .5,THR ROLL	1	
7	1243	BELT, A27, GATES HP-II	1	
7\$	0152 3	V-BELT, A28	1	
15	10229	SCREW, HHC 5/16-24 X 1"	4	
16	11049	PULLEY AK49 X 3/4"	1	
16\$	21140	PULLEY, AK-54 X 3/4" (LOW SPEED)	1	
28	21984	LIFTNG BALE ASSY.	1	
31	22623	ENGINE, HONDA GX270UT2QA2 (8.5 H.P.)	1	
32	22891	CLUTCH, FRICTION DRIVE W/ADJ. SHEAVE, 1.0"	1	
35	23965	SCREW, FHSC, 7/16-20 X 1.00"	1	
37	30119	SCREW, 1/4-20 X 7/8" IND HEX, DOG PT	3	
38	30199	BELT GUARD	1	
39	30344	BRACKET	1	
40	30202	ANCHOR, SPRING	1	
43	30236	SPACER, 1" SHAFT	1	
44	30240	END CAP, 1" SHAFT	1	
46	32448	SCREW, BHC, 5/16-18 X 1/2"	3	
48	933241	WASHER, FLAT SAE 5/16 GRD 9 YZ	8	
49	22587	LOW SPEED KIT	1.....	INCLUDES ITEMS W/\$

SPIDER ASSY.

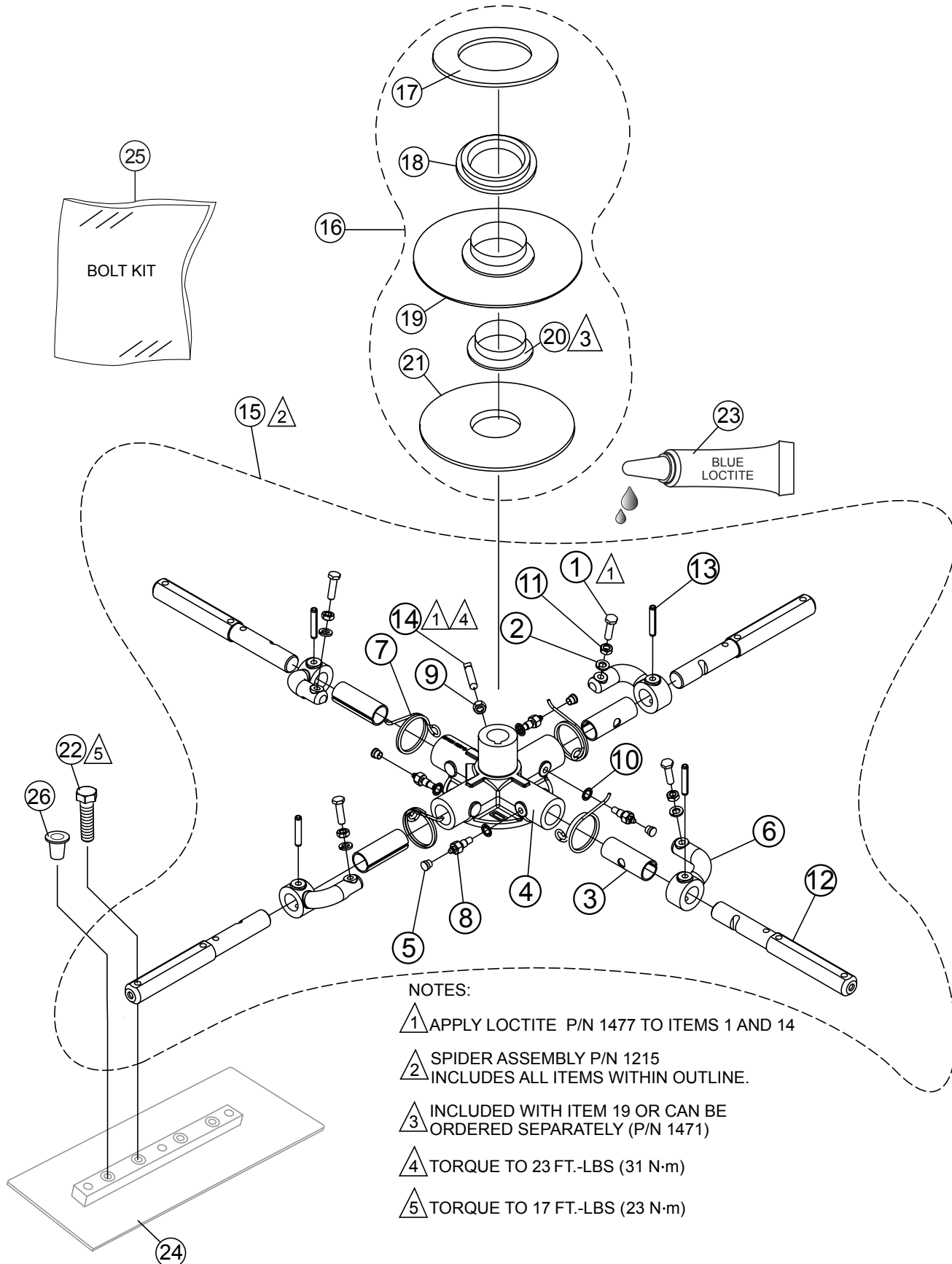

SPIDER ASSY.

<u>NO.</u>	<u>PART NO.</u>	<u>PART NAME</u>	<u>QTY.</u>	<u>REMARKS</u>
1%	0164 B	SCREW, HHC ROUNDED 3/8-16, FULL THREAD	4	
2%	0166 A	LOCK WASHER 3/8" MED	4	
3%	1157 A	BUSHING, TROWEL ARM	4	
4%	1161-1	SPIDER PLATE, 1-1/8" SHAFT 4BLD, SILVER	1	
5%	1162 A	CAP, GREASE ZERK #2 YELLOW	4	
6%	1163-1	LEVER, TROWEL ARM, SILVER	4	
7%	1316	SPRING, LS ARM RETURN	4	
8%	1322	RETAINING SCREW ASSY.	4	
9%	1456	NUT, HEX FINISH 3/8-16	1	
10%	1875	WASHER, INT. SHKP. 3/8"	4	
11%	1876	NUT, HEX JAM 3/8-16 CLASS 2B	4	
12%	2826-1	ARM, TROWEL, 9-3/4", SILVER	4	
13%	4164	ROLL PIN 5/16" X 1-3/4"	4	
14%	12097	SCREW, SQHS 3/8-16 X 1-3/4" CONE GRD 8 PLTD	1	
15	1215	SPIDER PLATE ASSY.,	1	INCLUDES ITEMS W/%
16	10968	THRUST COLLAR ASSY.	1	INCLUDES ITEMS W/\$
17\$	12208	WEAR RING	1	
18\$	12778	FLANGE BEARING	1	
19\$	10793	THRUST COLLAR	1	INCLUDES ITEMS W/#
20\$#	1471	THRUST COLLAR BUSHING	1	
21\$	1154 A	WEAR PLATE	1	
22@	21906	SCREW, HHCS 5/16-18 X 1-1/2" GRD 5	8	
23	1477	BLUE LOCTITE, #242	AR	
24		BLADE ASSY	4	CONTACT MQ UNIT SALES DEPT
25	23647	KIT, BOLT	1	INCLUDES ITEMS W/@
26@	1434	PLUG, BLADE	4	

BLADES AND PAN ASSY.

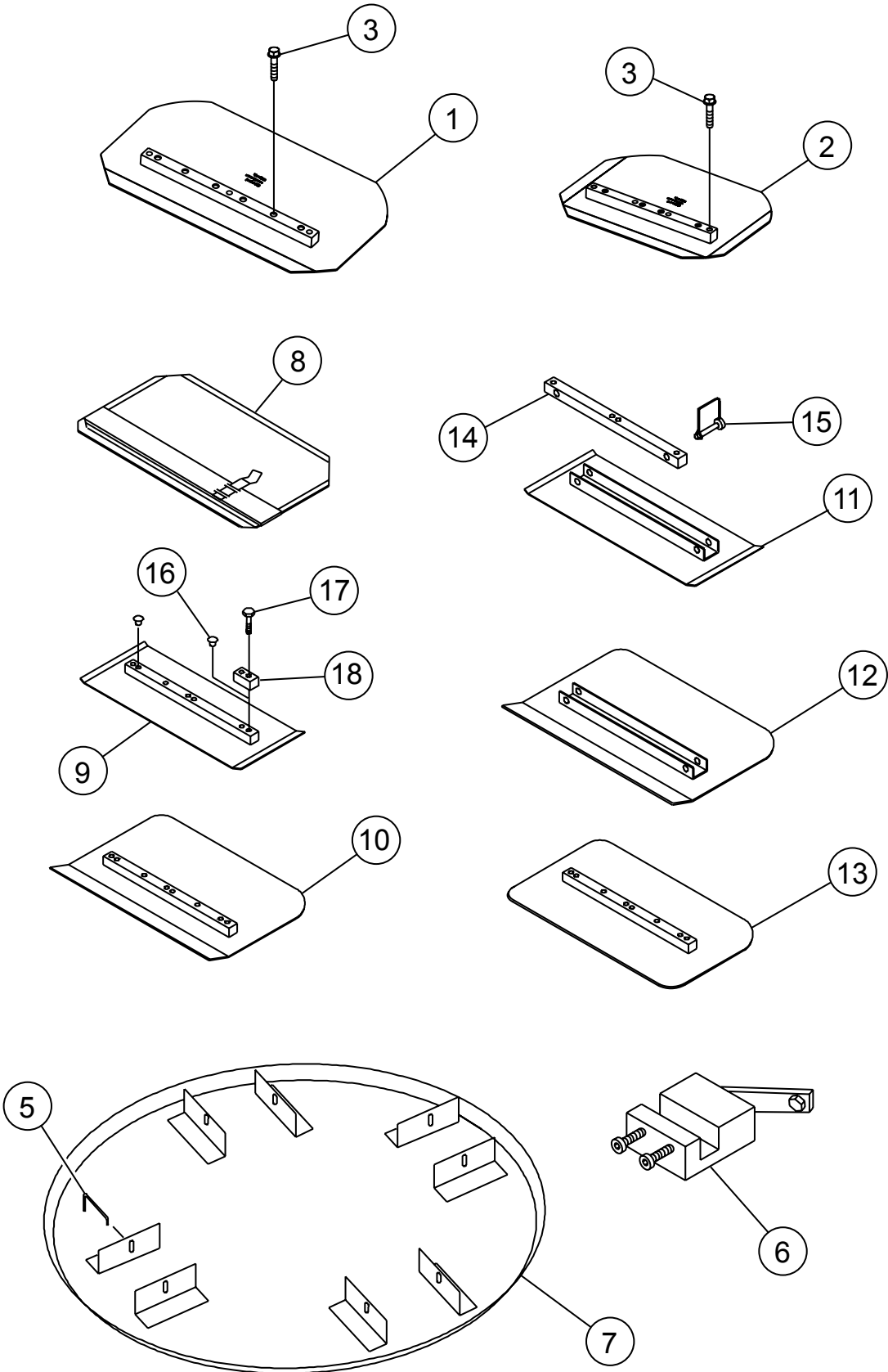

BLADES AND PAN ASSY.

<u>NO.</u>	<u>PART NO.</u>	<u>PART NAME</u>	<u>QTY.</u>	<u>REMARKS</u>
1		BLADE, COMBO 8" X 14".....	4.....	(ALL EXCEPT 30")
2		BLADE, COMBO 8 X 10-1/2".....	4.....	(30" TROWEL ONLY)
3	21906	SCREW, HHFS 5/16-18 X 1-1/2" GR5.....	8.....	ALL
5	20646	LATCH PIN FOR FLOAT PANS.....	4.....	CONTACT UNIT SALES DEPT./ ACC. ITEM
6	1817	TRWL ARM ADJ. FIXTURE 36" TO 46" MODELS.....	1.....	CONTACT UNITS SALES DEPT./ ACC. ITEM
7		FLOAT DISC.....	1.....	CONTACT UNIT SALES DEPT./ ACC. ITEM
8		FLOAT BLADE.....	4.....	CONTACT UNIT SALES DEPT./ ACC. ITEM
9		FINISH BLADE.....	4.....	CONTACT UNIT SALES DEPT./ ACC. ITEM
10		COMBO FLOAT & FINISH BLADE.....	4.....	CONTACT UNIT SALES DEPT./ ACC. ITEM
11		ENDURO UNIVERSAL FINISH BLADE.....	4.....	CONTACT UNIT SALES DEPT./ ACC. ITEM
12		ENDURO UNIVERSAL COMBO BLADE.....	4.....	CONTACT UNIT SALES DEPT./ ACC. ITEM
13		REVERSIBLE COMBO BLADE.....	4.....	CONTACT UNIT SALES DEPT./ ACC. ITEM
14		UNIVERSAL MOUNTING BAR.....	4.....	CONTACT UNIT SALES DEPT./ ACC. ITEM
15	QS1869	SNAP PIN FOR QC BLADES.....	8.....	CONTACT UNIT SALES DEPT./ ACC. ITEM
16	1434	PLUG, BLADE (FINISH BLADE ONLY)	4	
17	0202	SCREW, HHC 5/16-18 X 1" ZINC	4	
18	0201	LUG, GUARD RING	4	

HONDA GX270 — RECOIL STARTER ASSY.

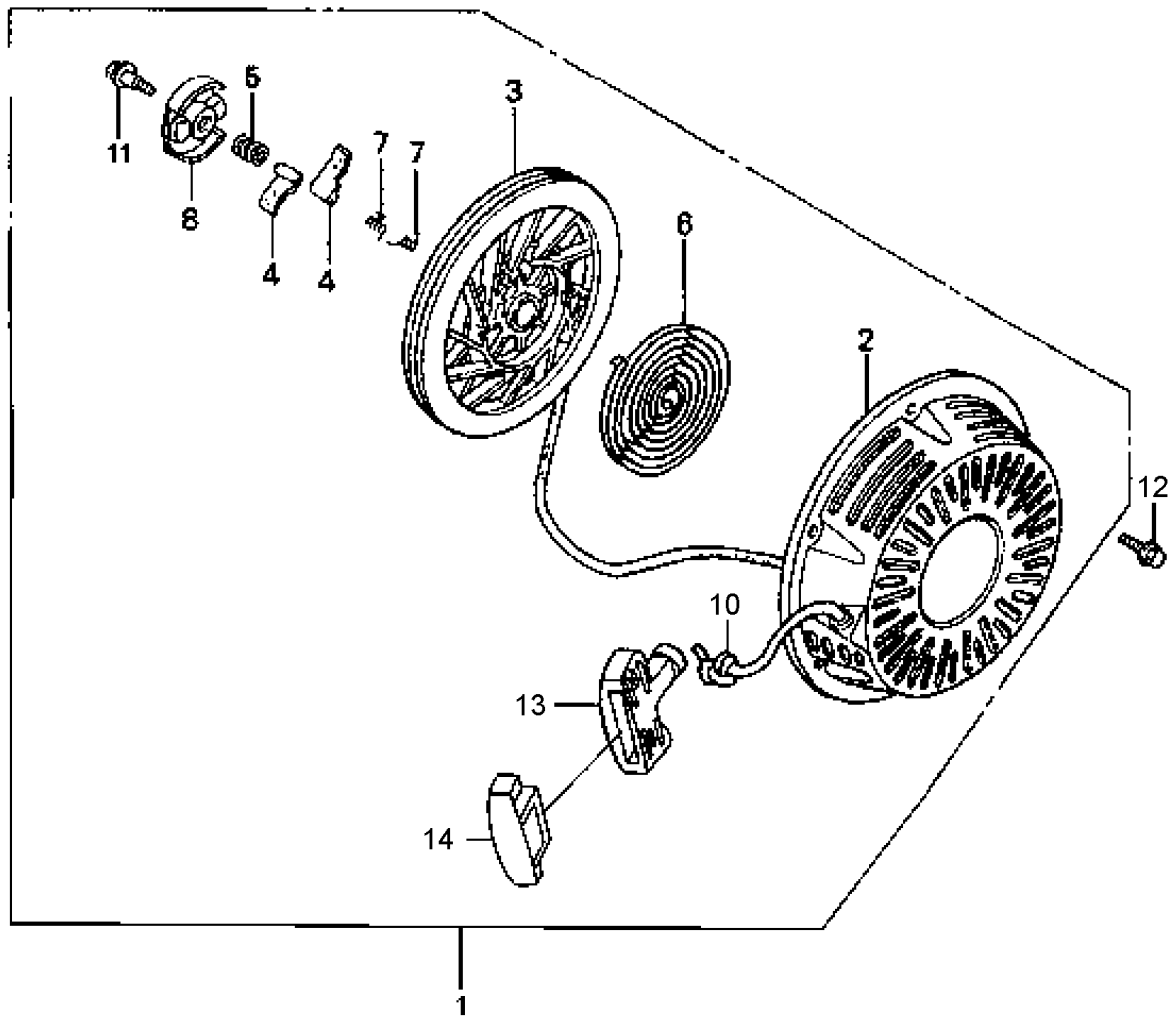

HONDA GX270 — RECOIL STARTER ASSY.

<u>NO.</u>	<u>PART NO.</u>	<u>PART NAME</u>	<u>QTY.</u>	<u>REMARKS</u>
1	28400Z5K305ZB	STARTER ASSY., RECOIL *NH1*	1.....	INCLUDES ITEMS W/# REPLACES P/N 28400Z5K003ZB
2#	28410ZE2W01ZB	CASE COMP., RECOIL STARTER, NH1, BLK	1	
3#	28421ZE2W01	PULLEY, RECOIL STARTER	1	
4#	28422ZE2W01	RATCHET, STARTER	2	
5#	28441ZE2W01	SPRING, FRICTION	1	
6#	28442ZE2W01	SPRING, STARTER RETURN	1	
7#	28443ZE2W01	SPRING, RATCHET	2	
8#	28444ZE2W01	RETAINER, SPRING	1	
10#	28462ZE2W11	ROPE, RECOIL STARTER	1	
11#	90004ZE2W01	SCREW, CENTER	1	
12	90008ZE2003	BOLT, FLANGE, 6X10	3	
13#	28461Z5T305	GRIP, STARTER	1	
14#	28463Z5T003	GRIP, REINFORCEMENT	1	

HONDA GX270 — FAN COVER ASSY.

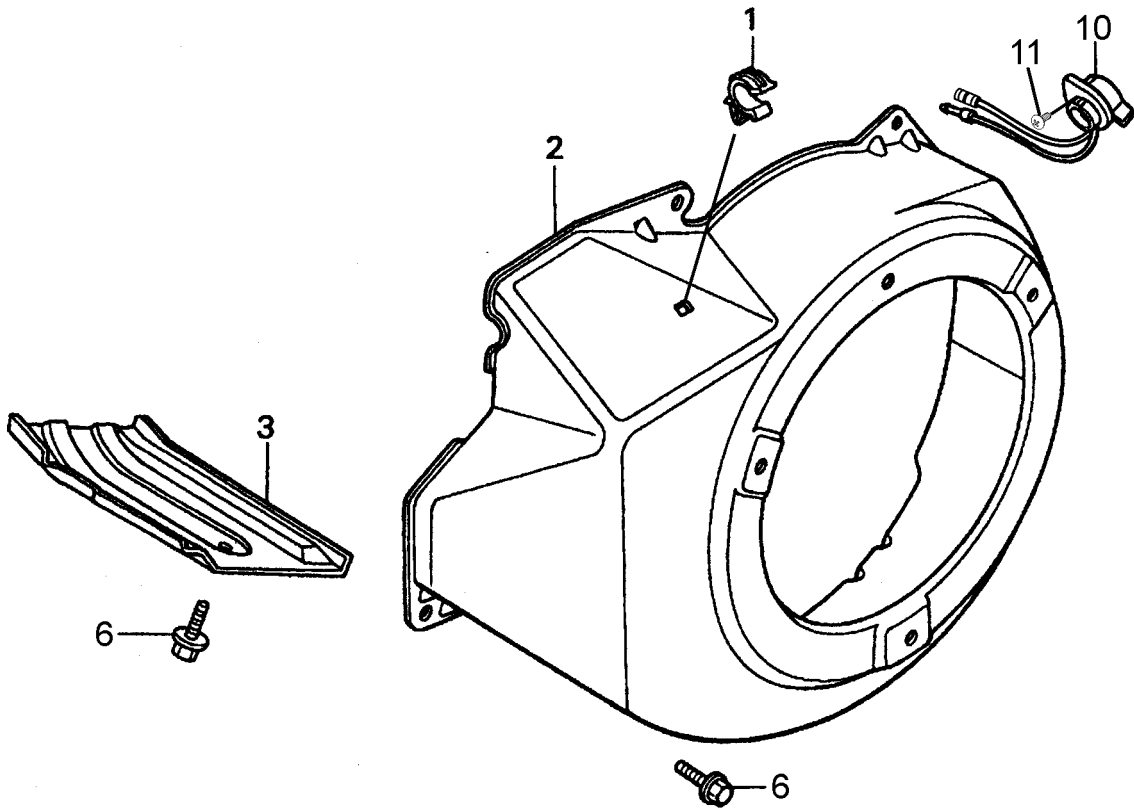

HONDA GX270 — FAN COVER ASSY.

<u>NO.</u>	<u>PART NO.</u>	<u>PART NAME</u>	<u>QTY.</u>	<u>REMARKS</u>
1	16731ZE2003	CLIP, TUBE	1	
2	19610Z5K000ZA	COVER COMP., FAN, NH1, BLACK	1	
3	19631Z5K000	SHROUD	1	
6	90013883000	BOLT, FLANGE, 6X12	6	
10	35120Z5T003	SWITCH ASSY., ENGINE STOP	1	
11	90004Z5T000	SCREW, TAPPING, 3X6	2	

HONDA GX270 — CARBURETOR ASSY.

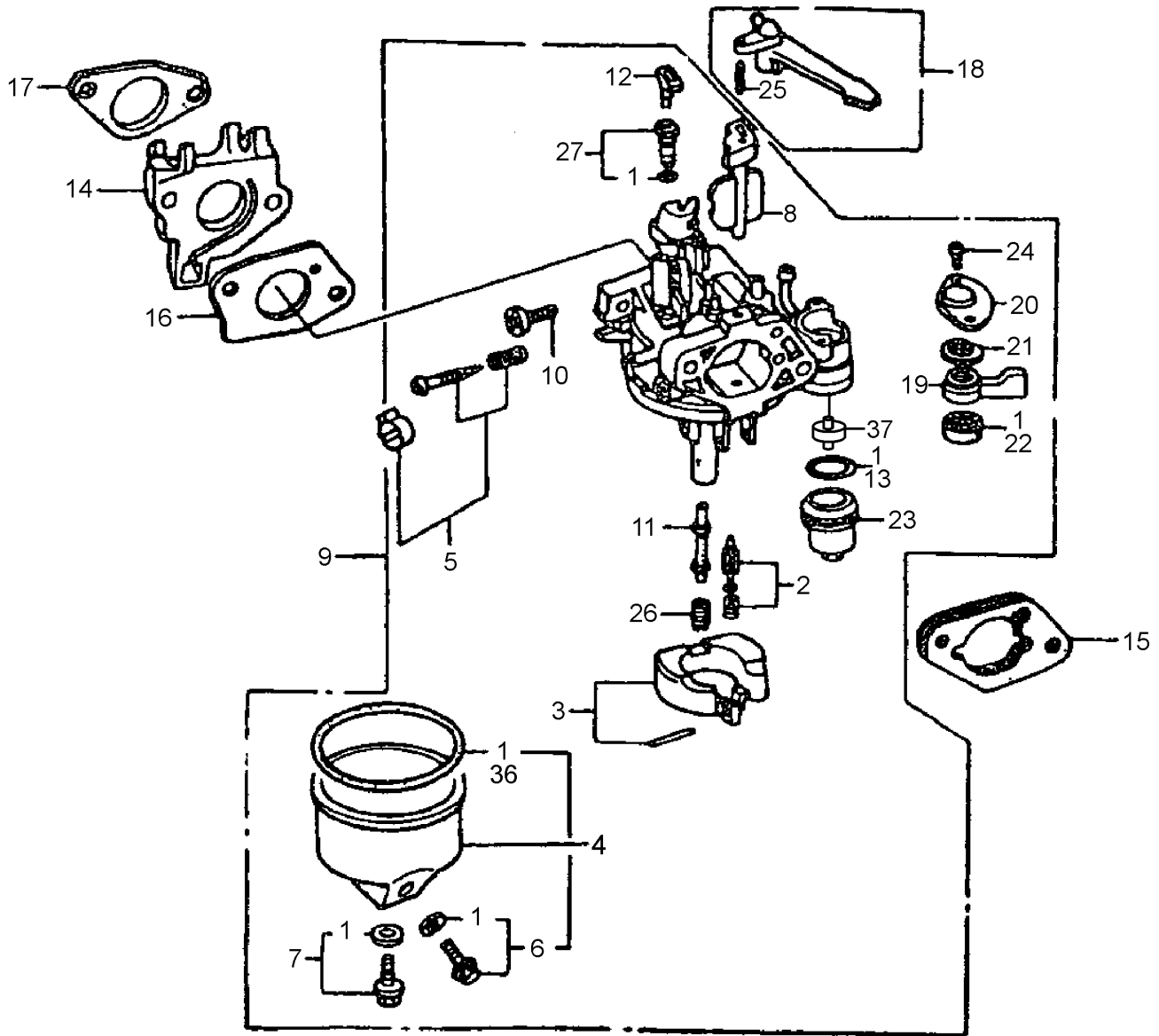

NOTICE

Gasket Set, item 1 included with items 6, 7, 13, 22, and 27.

HONDA GX270 — CARBURETOR ASSY.

<u>NO.</u>	<u>PART NO.</u>	<u>PART NAME</u>	<u>QTY.</u>	<u>REMARKS</u>
1#	16010ZE2812	GASKET SET	1	
2#	16011ZA0931	VALVE SET, FLOAT	1	
3#	16013Z1C003	FLOAT SET	1	
4#	16015Z5T901	CHAMBER SET, FLOAT	1	
5#	16016ZH7W01	SCREW SET, PILOT	1	
6#	16024Z5T901	SCREW SET, DRAIN	1	
7#	16028Z5T901	SCREW SET	1	
8#	16044ZE2005	CHOKE SET	1	
9	16100Z5KY01	CARBURETOR ASSY. (BE21J A)	1	INCLUDES ITEMS W/#
10#	16124ZE0005	SCREW, THROTTLE STOP	1	
11#	16166Z5KY01	NOZZLE, MAIN	1	
12#	16172ZE3W10	COLLAR, SETTING	1	
13#	16955283000	PACKING, FUEL STRAINER CUP	1	REPLACES P/N 16173001004
14	16211ZE2010	INSULATOR, CARBURETOR	1	
15	16220ZA0702	SPACER COMP., CARBURETOR	1	
16	16221Z5K000	PACKING, CARBURETOR	1	
17	16212Z5K000	PACKING, INSULATOR	1	
18	16610ZE1000	LEVER COMP., CHOKE (STD.)	1	INCLUDES ITEMS W/%
19#	16953ZE1812	LEVER, COCK	1	
20#	16954ZE1812	PLATE, LEVER SETTING	1	
21#	16956ZE1811	SPRING, COCK LEVER	1	
22#	16957ZE1812	PACKING, FUEL COCK	1	
23#	16967ZE0811	CUP, FUEL STRAINER	1	
24#	93500030060H	SCREW, PAN, 3X6	2	REPLACES P/N 93500030061H
25%	9430520122	PIN, SPRING, 2X12	1	
26#	99101ZH80820	JET, MAIN, #82	1	
26#	99101ZH80850	JET, MAIN, #85	1	
26#	99101ZH80880	JET, MAIN, #88	1	
27#	99204ZE20380	JET SET, PILOT, #38	1	
37#	16959Z5T901	FILTER, CUP	1	

HONDA GX270 — AIR CLEANER ASSY.

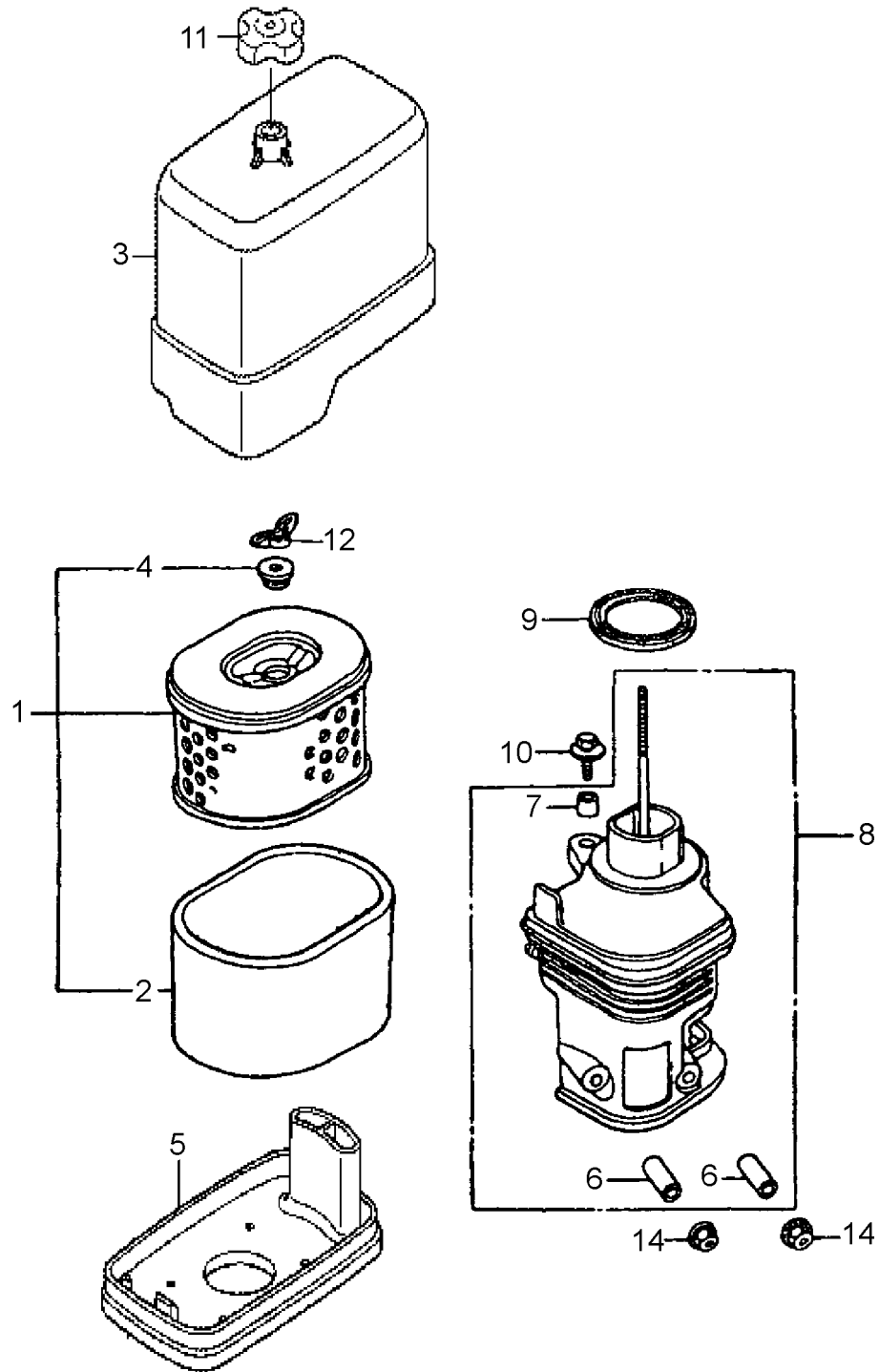

HONDA GX270 — AIR CLEANER ASSY.

<u>NO.</u>	<u>PART NO.</u>	<u>PART NAME</u>	<u>QTY.</u>	<u>REMARKS</u>
1	17210ZE2515	ELEMENT, AIR CLEANER (DUAL)	1.....	INCLUDES ITEMS W/# REPLACES P/N 17210ZE2822
2#	17218ZE2505	FILTER, OUTER	1.....	REPLACES P/N 17218ZE2821
3	17231Z5K000	COVER, AIR CLEANER CASE	1	
4#	17232891000	GROMMET, AIR CLEANER	1	
5	17235Z5K000	NOSE, SILENCER	1	
6%	17238ZE2310	COLLAR, AIR CLEANER	2	
7%	17239ZE1000	COLLAR B, AIR CLEANER	1	
8	17410Z5K000	ELBOW COMP., AIR CLEANER	1.....	INCLUDES ITEMS W/%
9	17417Z5T000	PACKING, AIR CLEANER CASE	1	
10	90009Z1C000	BOLTWASHER, 6X22	1	
11	90202Z2E000	NUT, AIR CLEANER COVER	1	
12	90325044000	NUT, TOOL BOX SETTING	1	
14	9405006000	NUT, FLANGE, 6MM	2	

HONDA GX270 — MUFFLER ASSY.

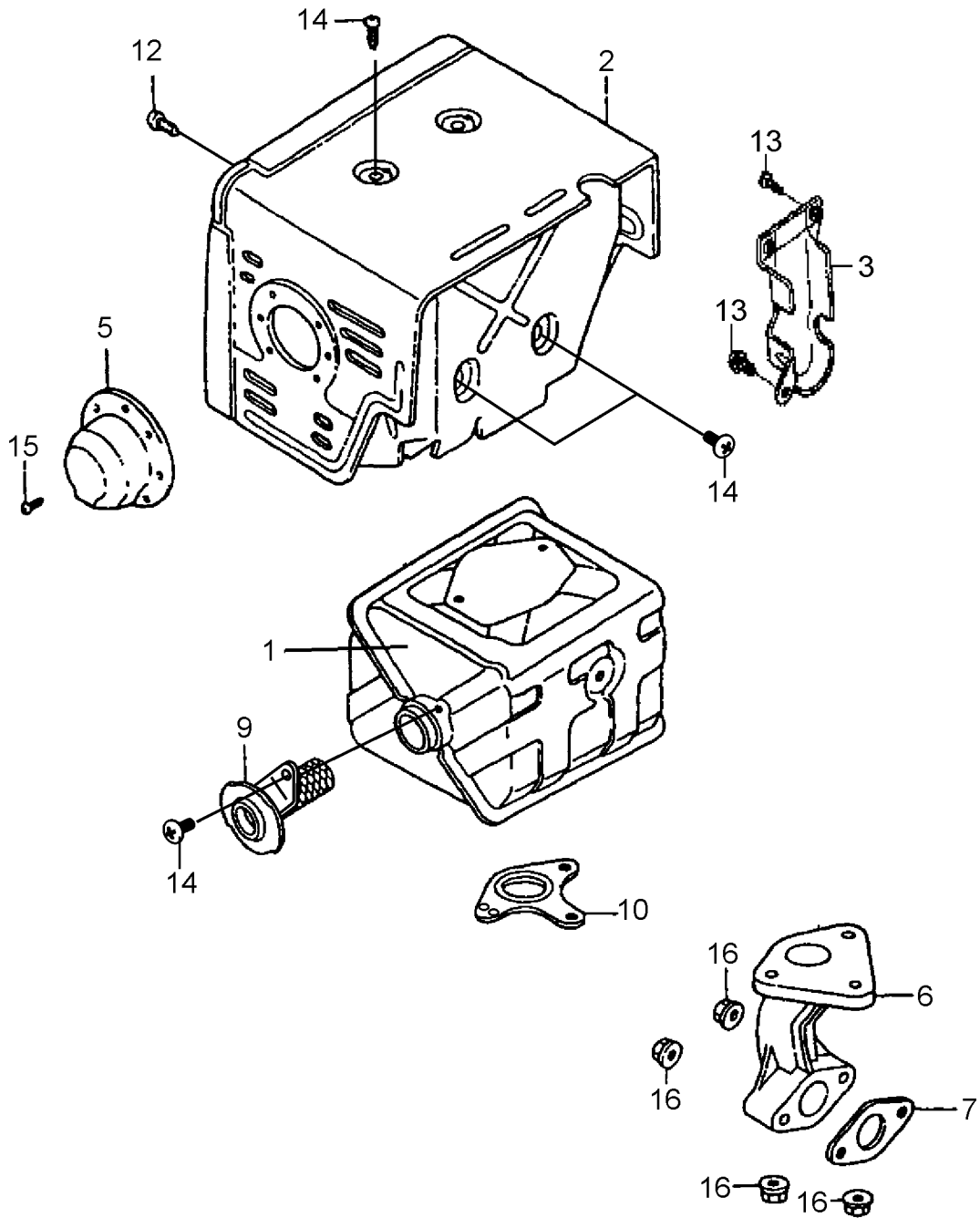

HONDA GX270 — MUFFLER ASSY.

<u>NO.</u>	<u>PART NO.</u>	<u>PART NAME</u>	<u>QTY.</u>	<u>REMARKS</u>
1	18310Z5K000	MUFFLER COMP.	1	
2	18320Z5K000	PROTECTOR COMP., MUFFLER	1	
3	18323ZE2W00	PROTECTOR, EX. PIPE	1	
5	18331ZE3811	CAP, MUFFLER	1	
6	18331Z5T000	PIPE, EX.	1	
7	18333Z1C801	GASKET, EX. PIPE	1	
9	18350Z5T800	ARRESTER COMP., SPARK	1	
10	18381ZE2W10	GASKET, MUFFLER (ARRESTER)	1	
12	90006ZE2000	SCREW, TAPPING, 6X10	1	
13	90013883000	BOLT, FLANGE, 6X12	1	
14	90050ZE1000	SCREW, TAPPING, 5X8	8	
15	90055ZE1000	SCREW, TAPPING, 4X6	3	
16	9405008000	NUT, FLANGE, 8MM	5	

HONDA GX270 — FUEL TANK ASSY.

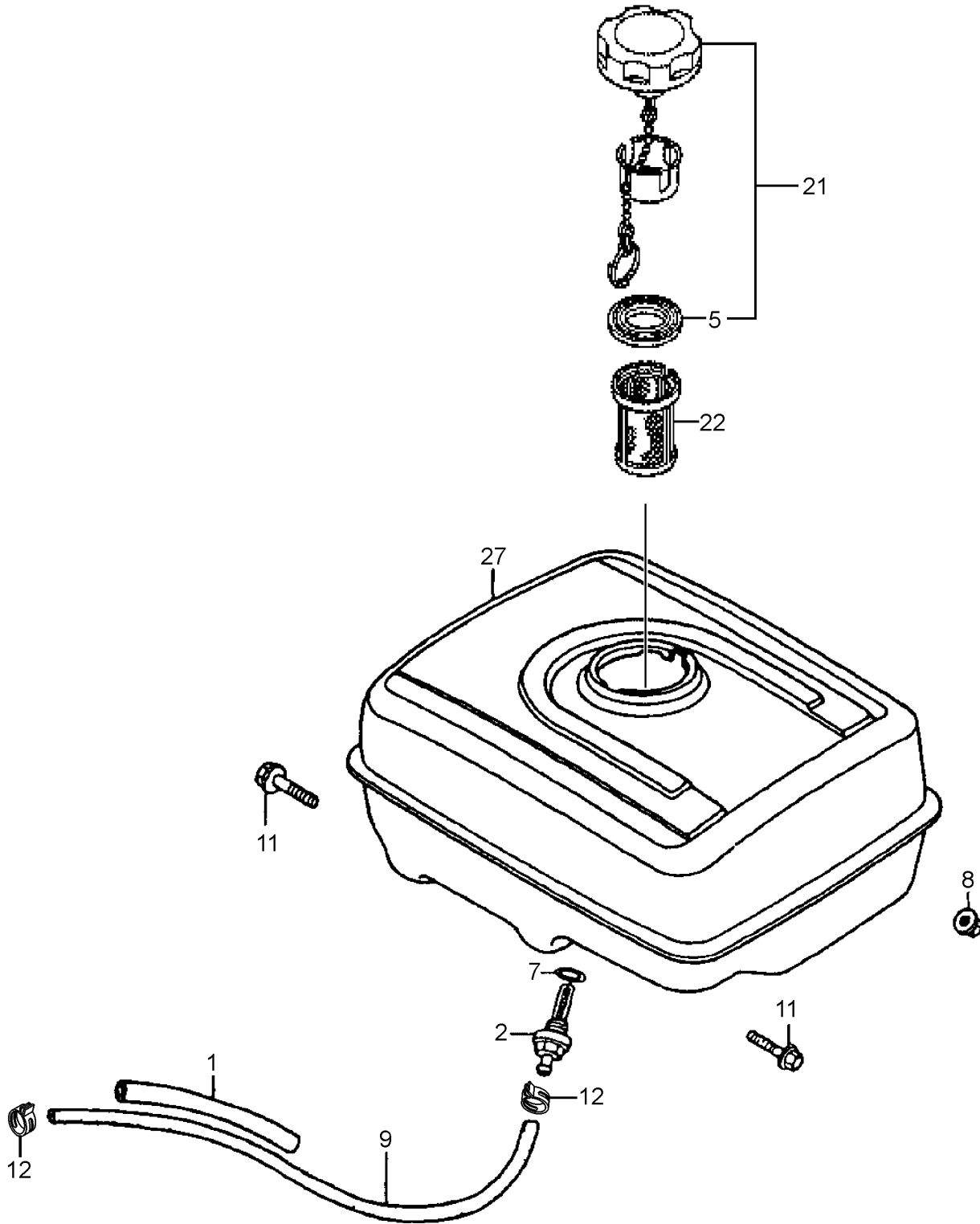

HONDA GX270 — FUEL TANK ASSY.

<u>NO.</u>	<u>PART NO.</u>	<u>PART NAME</u>	<u>QTY.</u>	<u>REMARKS</u>
1	16854ZH8000	RUBBER, SUPPORTER (107MM)	1	
2	16955ZE1010	JOINT, FUEL TANK	1	
5 #	17631Z0T801	PACKING, FUEL FILL. CAP	1	
7	91353671003	O-RING, 14MM	1	REPLACES P/N 91353671004
8	9405008000	NUT, FLANGE, 8MM	2	
9	91424Z5K003	TUBE, FUEL, 4.5X210	1	
11	957010802500	BOLT, FLANGE, 8X25	2	
12	950024080008	CLAMP, TUBE (D8)	2	
21	17620Z4H030	CAP COMP., FUEL FILL. (CHROME PLT.)	1	INCLUDES ITEM W/#
22	17672Z4H000	FILTER, FUEL	1	
27	17510Z5K000ZA	TANK COMP., FUEL, NH1 BLACK	1	

HONDA GX270 — FLYWHEEL ASSY.

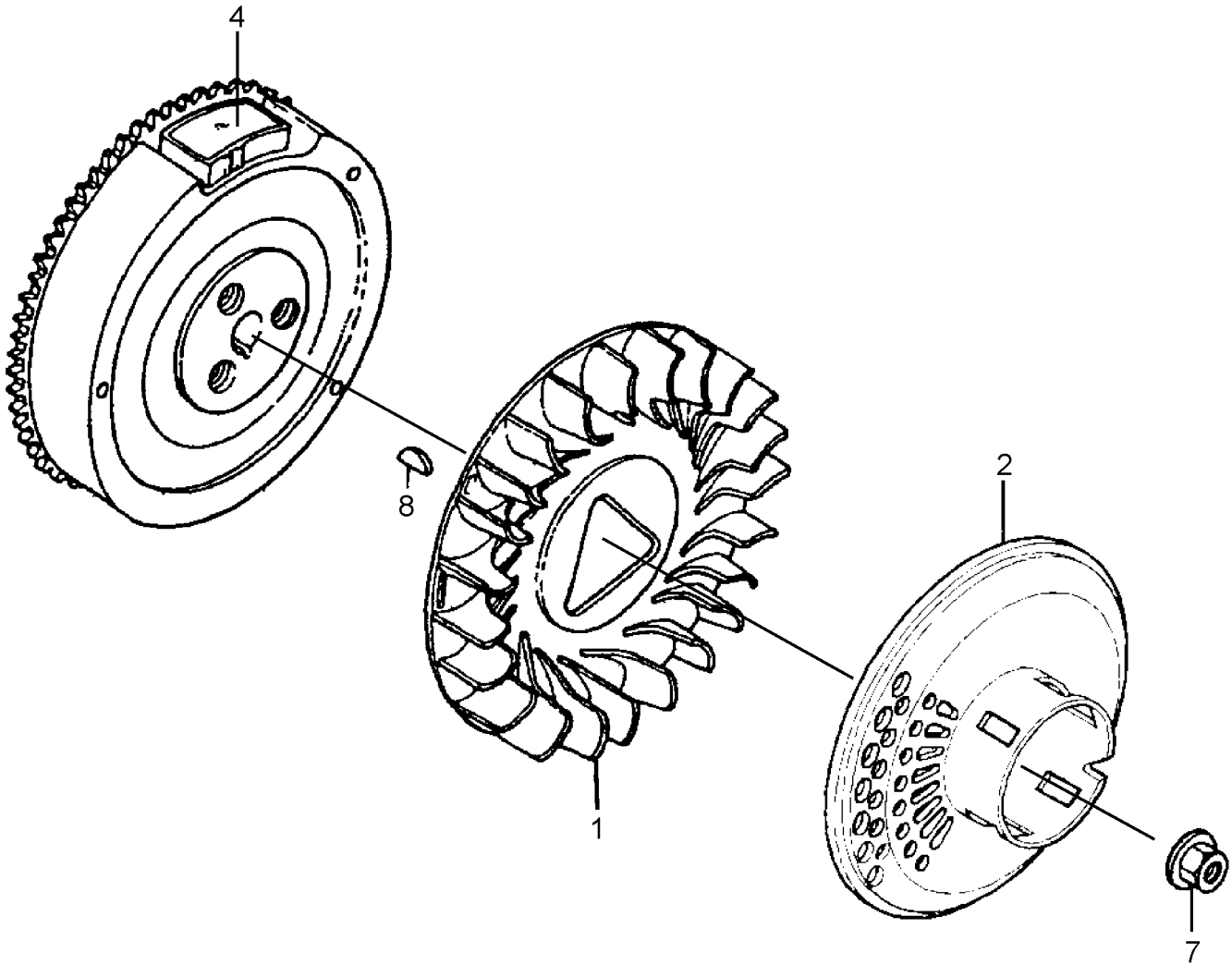

HONDA GX270 — FLYWHEEL ASSY.

<u>NO.</u>	<u>PART NO.</u>	<u>PART NAME</u>	<u>QTY.</u>	<u>REMARKS</u>
1	19511ZE2000	FAN, COOLING	1	
2	28450ZE2W11	PULLEY COMP., STARTER	1	
4	31110Z5K000	FLYWHEEL COMP.	1	
7	90201ZE3V00	NUT, SPECIAL, 16MM	1	
8	90741ZE2000	KEY, SPECIAL WOODRUFF, 25X18	1	

HONDA GX270 — CYLINDER HEAD ASSY.

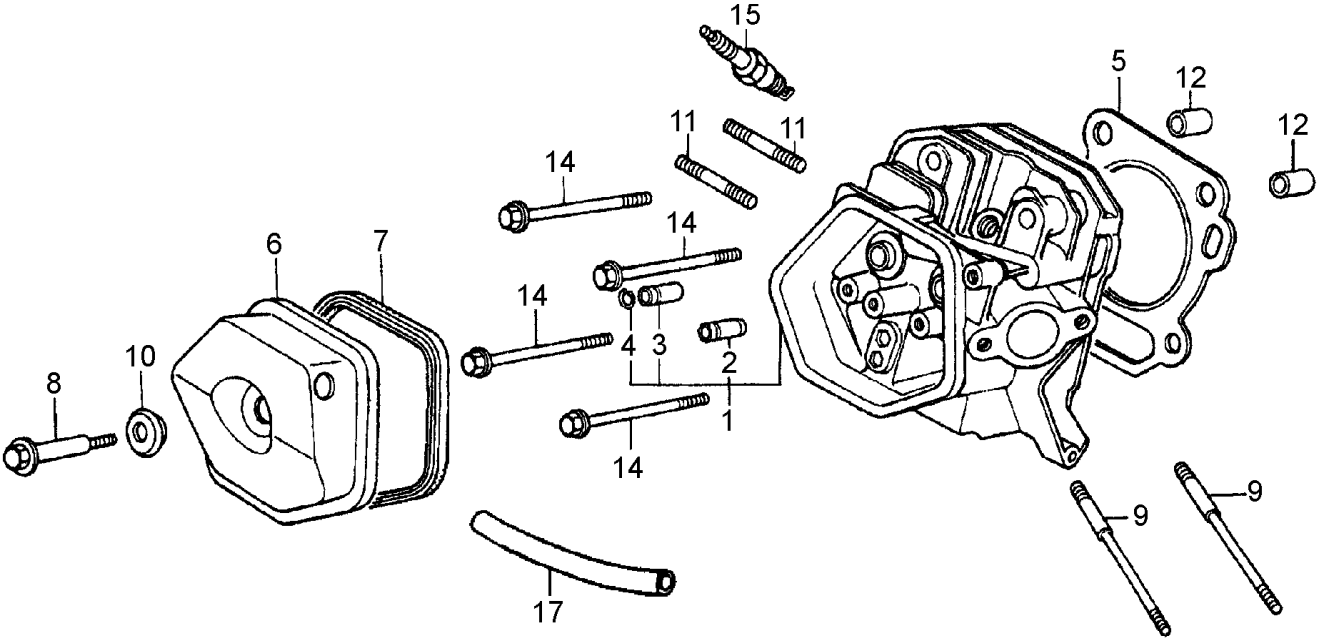

HONDA GX270 — CYLINDER HEAD ASSY.

<u>NO.</u>	<u>PART NO.</u>	<u>PART NAME</u>	<u>QTY.</u>	<u>REMARKS</u>
1	12210Z5K405	HEAD COMP., CYLINDER	1.....	INCLUDES ITEMS W/#
2#	12204ZE2306	GUIDE, IN. VALVE (O.S.)	1	
3#	12205ZE2305	GUIDE, EX. VALVE (O.S.)	1	
4#	12216ZE2300	CLIP, VALVE GUIDE	1	
5	12251Z5K003	GASKET, CYLINDER HEAD	1	
6	12310ZE2020	COVER COMP., HEAD	1	
7	12391ZE2020	PACKING, HEAD COVER	1	
8	90014Z5T000	BOLT, HEAD COVER	1	
9	90042ZE2000	BOLT, STUD, 8X123	2	
10	90441ZE2010	WASHER COMP., HEAD COVER	1	
11	92900080320E	BOLT, STUD, 8X32	2	
12	9430112200	DOWEL PIN, 12X20	2	
14	957011008000	BOLT, FLANGE, 10X80	4	
15	9807955876	PLUG, SPARK (BPR5ES)	1	
15	9807956846	PLUG, SPARK (BPR6ES)	1.....	REPLACES P/N 9807956876
17	12357Z5T020	TUBE, BREATHER	1	

HONDA GX270 — IGNITION COIL ASSY.

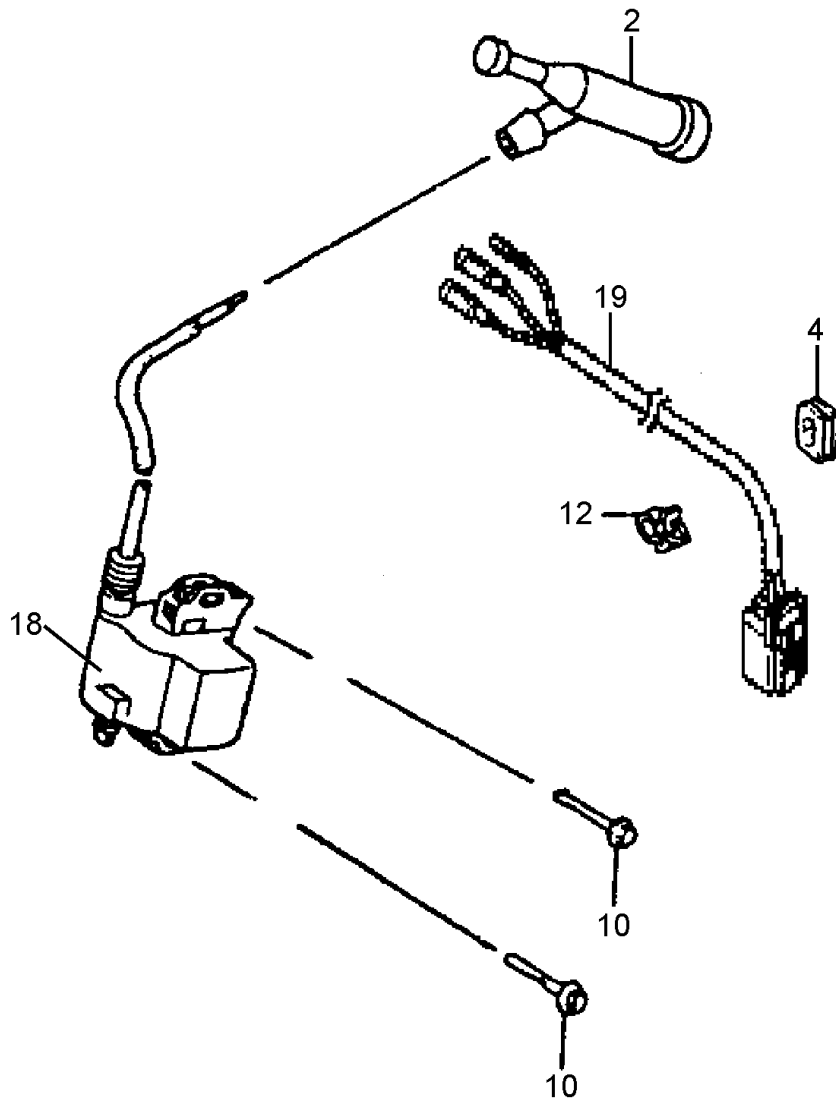

HONDA GX270 — IGNITION COIL ASSY.

<u>NO.</u>	<u>PART NO.</u>	<u>PART NAME</u>	<u>QTY.</u>	<u>REMARKS</u>
2	30700Z1C811	CAP ASSY., NOISE SUPPRESSOR	1	
4	31512ZE2000	GROMMET, CORD	1	
10	90015883000	BOLT, FLANGE, 6X28	2	
12	90684ZA0601	CLIP, HARNESS	1	
18	30500Z5K003	COIL ASSY., IGNITION	1	
19	32110Z5K000	HARNESS ASSY., ENGINE WIRE	1	

HONDA GX270 — CONTROL ASSY.

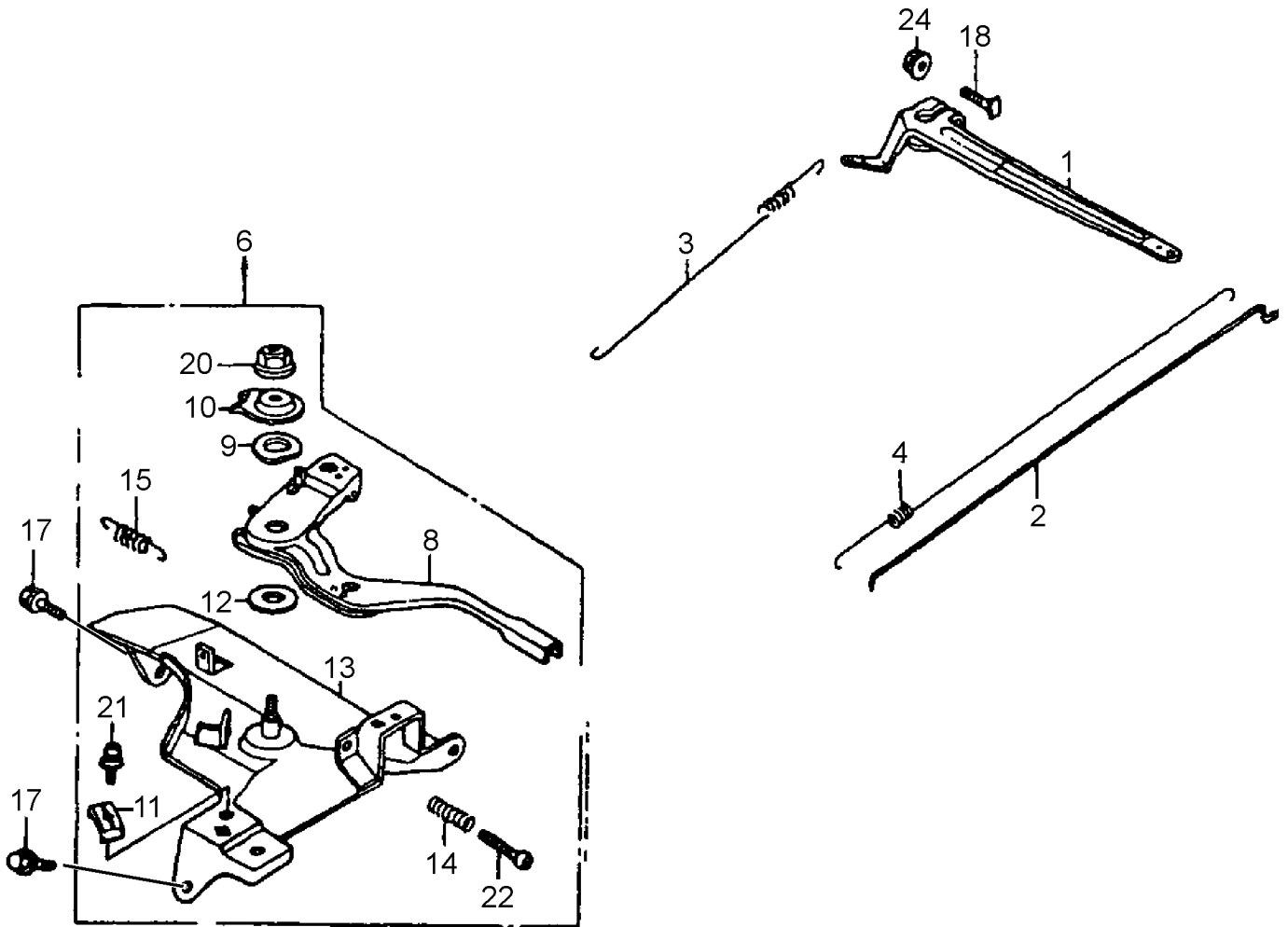

HONDA GX270 — CONTROL ASSY.

<u>NO.</u>	<u>PART NO.</u>	<u>PART NAME</u>	<u>QTY.</u>	<u>REMARKS</u>
1	16551ZE2000	ARM, GOVERNOR	1	
2	16555ZE2000	ROD, GOVERNOR	1	
3	16561ZE2000	SPRING, GOVERNOR (L=145.0MM)	1	
4	16562ZE2000	SPRING, THROTTLE RETURN	1	
6	16500Z5K307	CONTROL ASSY. (REMOTE)	1	INCLUDES ITEMS W/#
8#	16571ZE2W00	LEVER, CONTROL	1	
9#	16574ZE1000	SPRING, LEVER	1	
10#	16575ZE2W00	WASHER, CONTROL LEVER	1	
11#	16576891000	HOLDER, CABLE	1	
12#	16578ZE1000	SPACER, CONTROL LEVER	1	
13#	16580Z5K000	BASE COMP., CONTROL	1	
14#	16584883300	SPRING, CONTROL ADJUSTING	1	
15#	16592883310	SPRING, CABLE RETURN	1	
17	90013883000	BOLT, FLANGE, 6X12	2	
18	90015Z5T000	BOLT, GOVERNOR ARM	1	
20#	90114SA0000	NUT, SELFLOCK, 6MM	1	
21#	0202005T125	SCREW, PAN, 5X16	1	REPLACES P/N 93500050160A
22#	93500050280A	SCREW, PAN, 5X28	1	
24	9405006000	NUT, FLANGE, 6MM	1	

HONDA GX270 — CYLINDER BARREL ASSY.

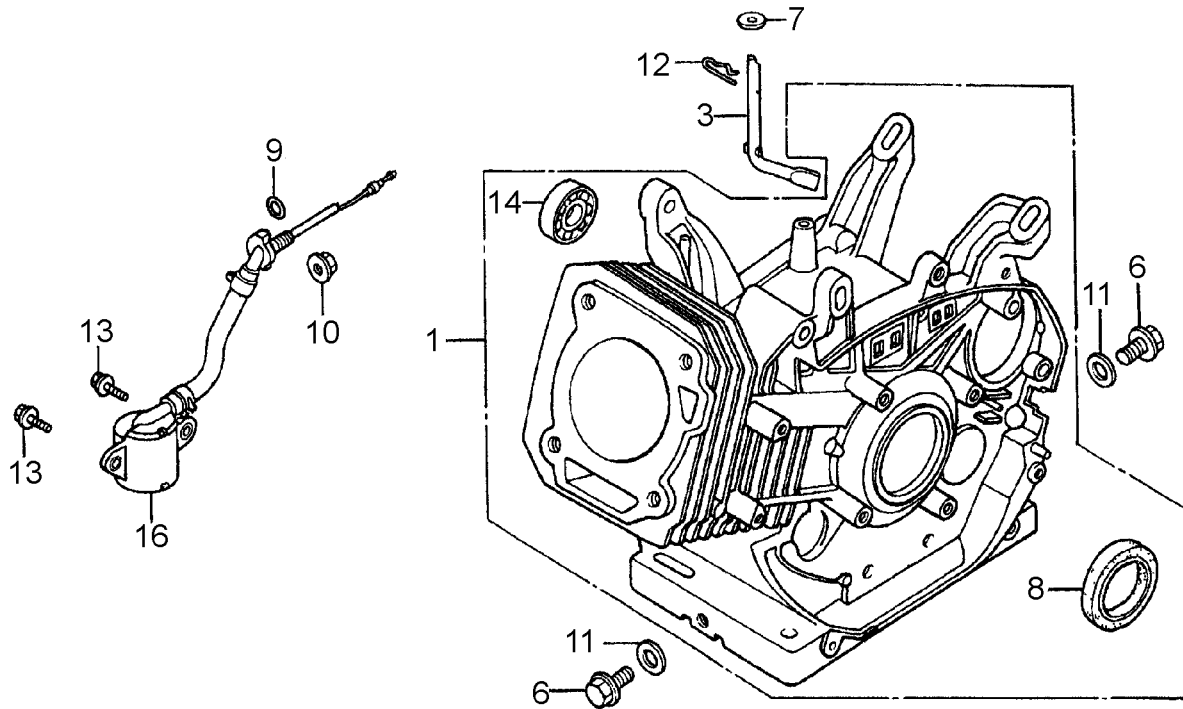

HONDA GX270 — CYLINDER BARREL ASSY.

<u>NO.</u>	<u>PART NO.</u>	<u>PART NAME</u>	<u>QTY.</u>	<u>REMARKS</u>
1	12000Z5KQ00	BARREL ASSY., CYLINDER	1.....	INCLUDES ITEMS W/#
3	16541ZE2010	SHAFT, GOVERNOR ARM	1	
6	90131896650	BOLT, DRAIN PLUG, 12X15	2.....	REPLACES P/N 90131883000
7	90446KE1000	WASHER, 8.2X17X0.8	1	
8#	91201Z1D003	OIL SEAL, 30X46X8	1	
9	91353671003	ORING, 14MM	1.....	REPLACES P/N 91353671004
10	9405010000	NUT, FLANGE, 10MM	1	
11	031112230	WASHER, DRAIN PLUG, 12MM	2.....	REPLACES P/N 9410912000
12	9425110000	PIN, LOCK, 10MM	1	
13	957010601200	BOLT, FLANGE, 6X12	2	
14#	961006202000	BEARING, RADIAL BALL, 6202	1	
16	35480ZF6003	SWITCH ASSY., OIL LEVEL	1	

HONDA GX270 — CRANKCASE COVER ASSY.

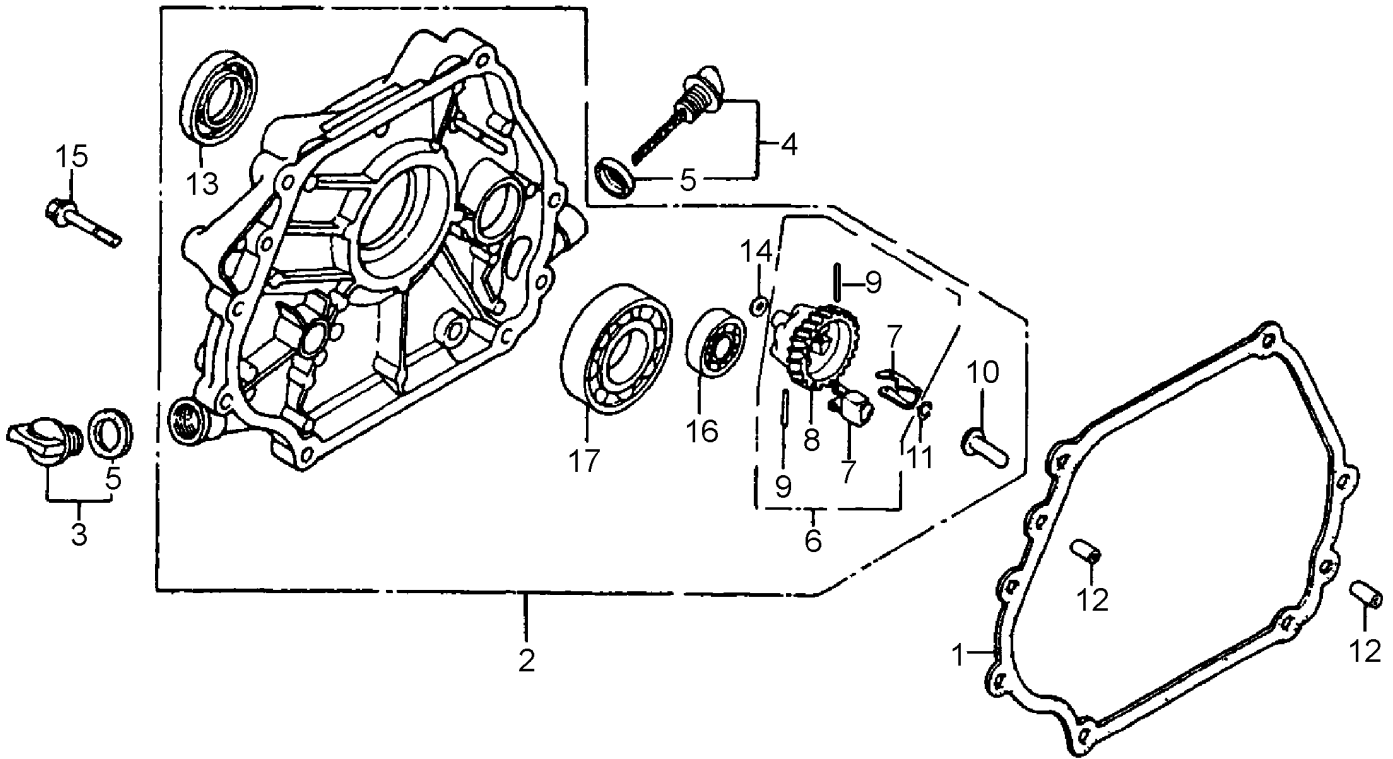

HONDA GX270 — CRANKCASE COVER ASSY.

<u>NO.</u>	<u>PART NO.</u>	<u>PART NAME</u>	<u>QTY.</u>	<u>REMARKS</u>
1	11381Z5K000	PACKING, CASE COVER	1	
2	11400Z1D600	COVER ASSY., CRANKCASE	1	INCLUDES ITEMS W/#
3	15600Z0T820	CAP ASSY., OIL FILLER	1	INCLUDES ITEMS W/%
4	15600Z1C000	CAP ASSY., OIL FILLER	1	INCLUDES ITEMS W/\$
5%\$	15625Z0T800	PACKING, OIL FILLER CAP	2	
6#	16510ZE2811	GOVERNOR ASSY.	1	INCLUDES ITEMS W/@
7#@	16511ZE2000	WEIGHT, GOVERNOR	2	
8#@	16512ZE2811	HOLDER, GOVERNOR WEIGHT	1	
9#@	16513ZE2000	PIN, GOVERNOR WEIGHT	2	
10#	16531Z0A000	SLIDER, GOVERNOR	1	
11#	90602ZE1000	CLIP, GOVERNOR HOLDER	1	
12	90701HC4000	DOWEL PIN, 8X12	2	
13#	91201Z1D003	OIL SEAL, 30X46X8	1	
14#	58176	WASHER, FLAT 6MM	1	REPLACES P/N 9410106800
15	957010803500	BOLT, FLANGE, 8X35	7	
16#	961006202000	BEARING, RADIAL BALL, 6202	1	
17#	961006206000	BEARING, RADIAL BALL, 6206	1	

HONDA GX270 — CRANKSHAFT ASSY.

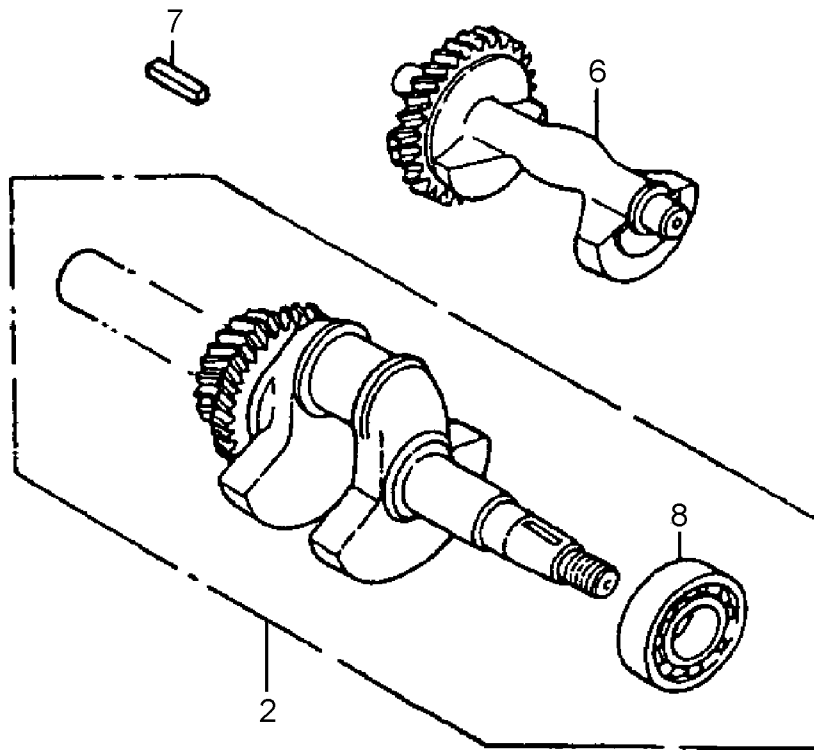

HONDA GX270 — CRANKSHAFT ASSY.

<u>NO.</u>	<u>PART NO.</u>	<u>PART NAME</u>	<u>QTY.</u>	<u>REMARKS</u>
2	13310ZH9811	CRANKSHAFT COMP.	1.....	INCLUDES ITEM W/#
6	13351ZE2010	WEIGHT, BALANCER	1	
7	90745ZE2600	KEY, 6.3X6.3X43	1	
8#	91001ZH9003	BEARING, RADIAL BALL	1	

HONDA GX270 — PISTON ASSY.

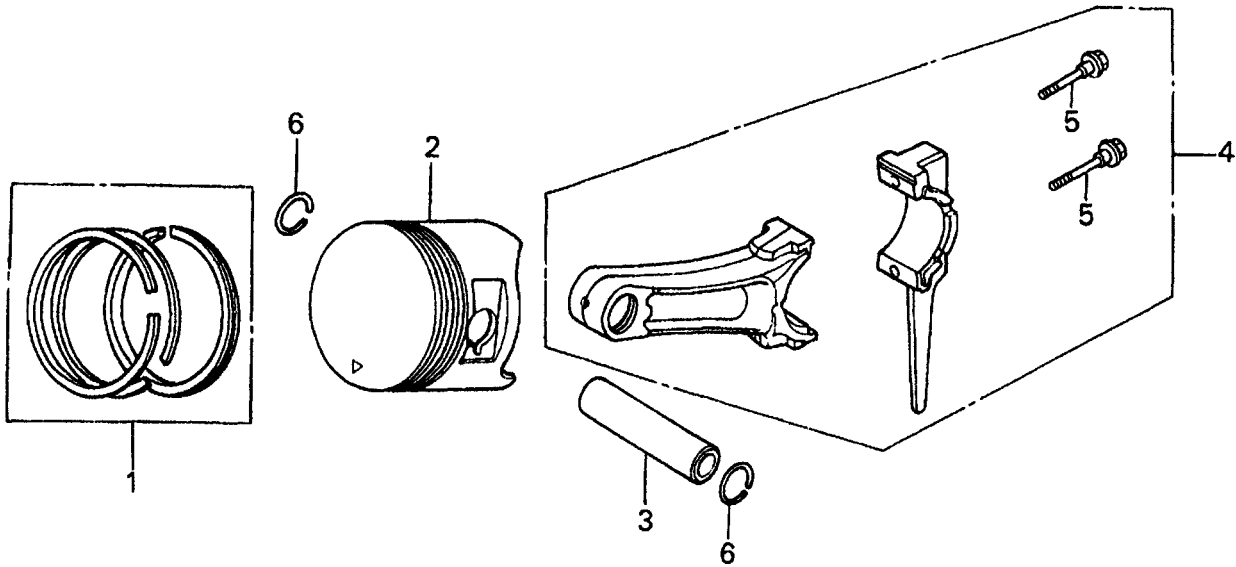

HONDA GX270 — PISTON ASSY.

<u>NO.</u>	<u>PART NO.</u>	<u>PART NAME</u>	<u>QTY.</u>	<u>REMARKS</u>
1	13010Z5K004	RING SET, PISTON (STD.)	1	
1	13011Z5K004	RING SET, PISTON (0.25)	1	
1	13012Z5K004	RING SET, PISTON (0.50)	1	
1	13013Z5K004	RING SET, PISTON (0.75)	1	
2	13101Z5K000	PISTON (STD.)	1	
2	13102Z5K000	PISTON (0.25)	1	
2	13103Z5K000	PISTON (0.50)	1	
2	13104Z5K000	PISTON (0.75)	1	
3	13111Z5K000	PIN, PISTON	1	
4	13200Z1D000	ROD ASSY., CONNECTING (STD.)	1	INCLUDES ITEMS W/#
4	13200Z1D305	ROD ASSY., CONNEC. (0.25 UNDER SIZE)	1	INCLUDES ITEMS W/#
5#	90001ZE8000	BOLT, CONNECTING ROD	2	
6	90551ZE1000	CLIP, PISTON PIN, 18MM	2	

HONDA GX270 — CAMSHAFT ASSY.

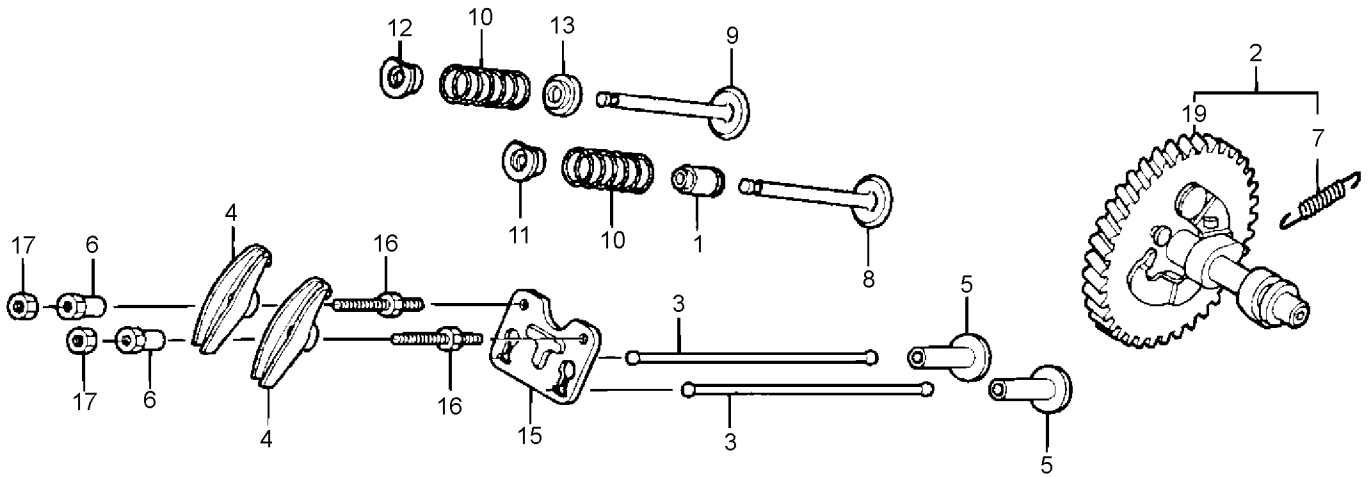

HONDA GX270 — CAMSHAFT ASSY.

<u>NO.</u>	<u>PART NO.</u>	<u>PART NAME</u>	<u>QTY.</u>	<u>REMARKS</u>
1	12209ZE8003	SEAL, VALVE STEM	1	
2	14100Z5K810	CAMSHAFT ASSY.....	1.....	INCLUDES ITEMS W/# S/N 1043291 AND BELOW
3	14410Z1D000	ROD, PUSH	2	
4	14431ZE2010	ARM, VALVE ROCKER	2	
5	14441ZE2000	LIFTER, VALVE	2	
6	14451ZE1013	PIVOT, ROCKER ARM	2	
7#	14568ZE1000	SPRING, WEIGHT RETURN	1.....	S/N 1043291 AND BELOW
8	14711Z5K000	VALVE, IN.	1	
9	14721Z5K000	VALVE, EX.	1	
10	14751Z1C000	SPRING, VALVE	2	
11	14771Z8S000	RETAINER, IN. VALVE SPRING	1	
12	14771Z8S000	RETAINER, IN. VALVE SPRING	1	
13	14775ZE2010	SEAT, VALVE SPRING	1	
15	14791Z1D000	GUIDE, PUSH ROD	1	
16	90012ZE0010	BOLT, PIVOT, 8MM	2	
17	90206ZE1000	NUT, PIVOT ADJUSTING	2	
19#	14100Z5K910	CAMSHAFT COMP.....	1.....	S/N 1043292 AND ABOVE

HONDA GX270 — LABEL ASSY.

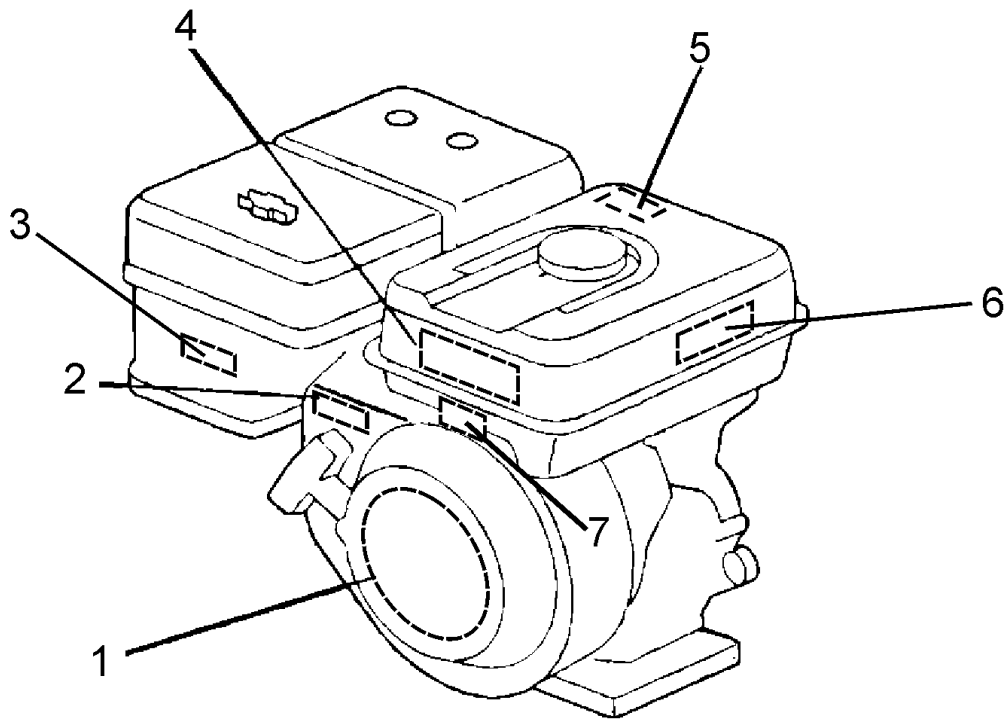

HONDA GX270— LABEL ASSY.

<u>NO.</u>	<u>PART NO.</u>	<u>PART NAME</u>	<u>QTY.</u>	<u>REMARKS</u>
1	87521Z5K000	EMBLEM (GX270)	1	
2	87532ZH7000	MARK, THROTTLE INDICATION	1	
3	87528Z5T000	MARK, CHOKE	1	
4	87519Z4H000	MARK, OPERATOR CAUTION	1	
5	87539Z0J000	MARK, EX, CAUTION	1	
6	87516Z4H010	MARK, OPERATOR CAUTION	1	
7	87539Z0J800	MARK, EX. CAUTION	1	

TERMS AND CONDITIONS OF SALE — PARTS

PAYMENT TERMS

Terms of payment for parts are net 30 days.

FREIGHT POLICY

All parts orders will be shipped collect or prepaid with the charges added to the invoice. All shipments are F.O.B. point of origin. Multiquip's responsibility ceases when a signed manifest has been obtained from the carrier, and any claim for shortage or damage must be settled between the consignee and the carrier.

MINIMUM ORDER

The minimum charge for orders from Multiquip is \$15.00 net. Customers will be asked for instructions regarding handling of orders not meeting this requirement.

RETURNED GOODS POLICY

Return shipments will be accepted and credit will be allowed, subject to the following provisions:

1. A Returned Material Authorization must be approved by Multiquip prior to shipment.
2. To obtain a Return Material Authorization, a list must be provided to Multiquip Parts Sales that defines item numbers, quantities, and descriptions of the items to be returned.
 - a. The parts numbers and descriptions must match the current parts price list.
 - b. The list must be typed or computer generated.
 - c. The list must state the reason(s) for the return.
 - d. The list must reference the sales order(s) or invoice(s) under which the items were originally purchased.
 - e. The list must include the name and phone number of the person requesting the RMA.
3. A copy of the Return Material Authorization must accompany the return shipment.
4. Freight is at the sender's expense. All parts must be returned freight prepaid to Multiquip's designated receiving point.

5. Parts must be in new and resalable condition, in the original Multiquip package (if any), and with Multiquip part numbers clearly marked.
6. The following items are not returnable:
 - a. Obsolete parts. (If an item is in the price book and shows as being replaced by another item, it is obsolete.)
 - b. Any parts with a limited shelf life (such as gaskets, seals, "O" rings, and other rubber parts) that were purchased more than six months prior to the return date.
 - c. Any line item with an extended dealer net price of less than \$5.00.
 - d. Special order items.
 - e. Electrical components.
 - f. Paint, chemicals, and lubricants.
 - g. Decals and paper products.
 - h. Items purchased in kits.
7. The sender will be notified of any material received that is not acceptable.
8. Such material will be held for five working days from notification, pending instructions. If a reply is not received within five days, the material will be returned to the sender at his expense.
9. Credit on returned parts will be issued at dealer net price at time of the original purchase, less a 15% restocking charge.
10. In cases where an item is accepted, for which the original purchase document can not be determined, the price will be based on the list price that was effective twelve months prior to the RMA date.
11. Credit issued will be applied to future purchases only.

PRICING AND REBATES

Prices are subject to change without prior notice. Price changes are effective on a specific date and all orders received on or after that date will be billed at the revised price. Rebates for price declines and added charges for price increases will not be made for stock on hand at the time of any price change.

Multiquip reserves the right to quote and sell direct to Government agencies, and to Original Equipment Manufacturer accounts who use our products as integral parts of their own products.

SPECIAL EXPEDITING SERVICE

A \$35.00 surcharge will be added to the invoice for special handling including bus shipments, insured parcel post or in cases where Multiquip must personally deliver the parts to the carrier.

LIMITATIONS OF SELLER'S LIABILITY

Multiquip shall not be liable hereunder for damages in excess of the purchase price of the item with respect to which damages are claimed, and in no event shall Multiquip be liable for loss of profit or good will or for any other special, consequential or incidental damages.

LIMITATION OF WARRANTIES

No warranties, express or implied, are made in connection with the sale of parts or trade accessories nor as to any engine not manufactured by Multiquip. Such warranties made in connection with the sale of new, complete units are made exclusively by a statement of warranty packaged with such units, and Multiquip neither assumes nor authorizes any person to assume for it any other obligation or liability whatever in connection with the sale of its products. Apart from such written statement of warranty, there are no warranties, express, implied or statutory, which extend beyond the description of the products on the face hereof.

Effective: February 22, 2006

OPERATION AND PARTS MANUAL

HERE'S HOW TO GET HELP

PLEASE HAVE THE MODEL AND SERIAL
NUMBER ON-HAND WHEN CALLING

UNITED STATES

Multiquip Corporate Office

18910 Wilmington Ave.
Carson, CA 90746
Contact: mq@multiquip.com

Tel. (800) 421-1244
Fax (310) 537-3927

Service Department

800-421-1244
310-537-3700

Fax: 310-537-4259

Technical Assistance

800-478-1244

Fax: 310-943-2238

MQ Parts Department

800-427-1244
310-537-3700

Fax: 800-672-7877
Fax: 310-637-3284

Warranty Department

800-421-1244
310-537-3700

Fax: 310-943-2249

CANADA

Multiquip

4110 Industriel Boul.
Laval, Quebec, Canada H7L 6V3
Contact: jmartin@multiquip.com

Tel: (450) 625-2244
Tel: (877) 963-4411
Fax: (450) 625-8664

UNITED KINGDOM

Multiquip (UK) Limited Head Office

Unit 2, Northpoint Industrial Estate,
Globe Lane,
Dukinfield, Cheshire SK16 4UJ
Contact: sales@multiquip.co.uk

Tel: 0161 339 2223
Fax: 0161 339 3226

© COPYRIGHT 2015, MULTIQUIP INC.

Multiquip Inc, the MQ logo are registered trademarks of Multiquip Inc. and may not be used, reproduced, or altered without written permission. All other trademarks are the property of their respective owners and used with permission.

This manual MUST accompany the equipment at all times. This manual is considered a permanent part of the equipment and should remain with the unit if resold.

The information and specifications included in this publication were in effect at the time of approval for printing. Illustrations, descriptions, references and technical data contained in this manual are for guidance only and may not be considered as binding. Multiquip Inc. reserves the right to discontinue or change specifications, design or the information published in this publication at any time without notice and without incurring any obligations.

Your Local Dealer is:



PN: 30221