

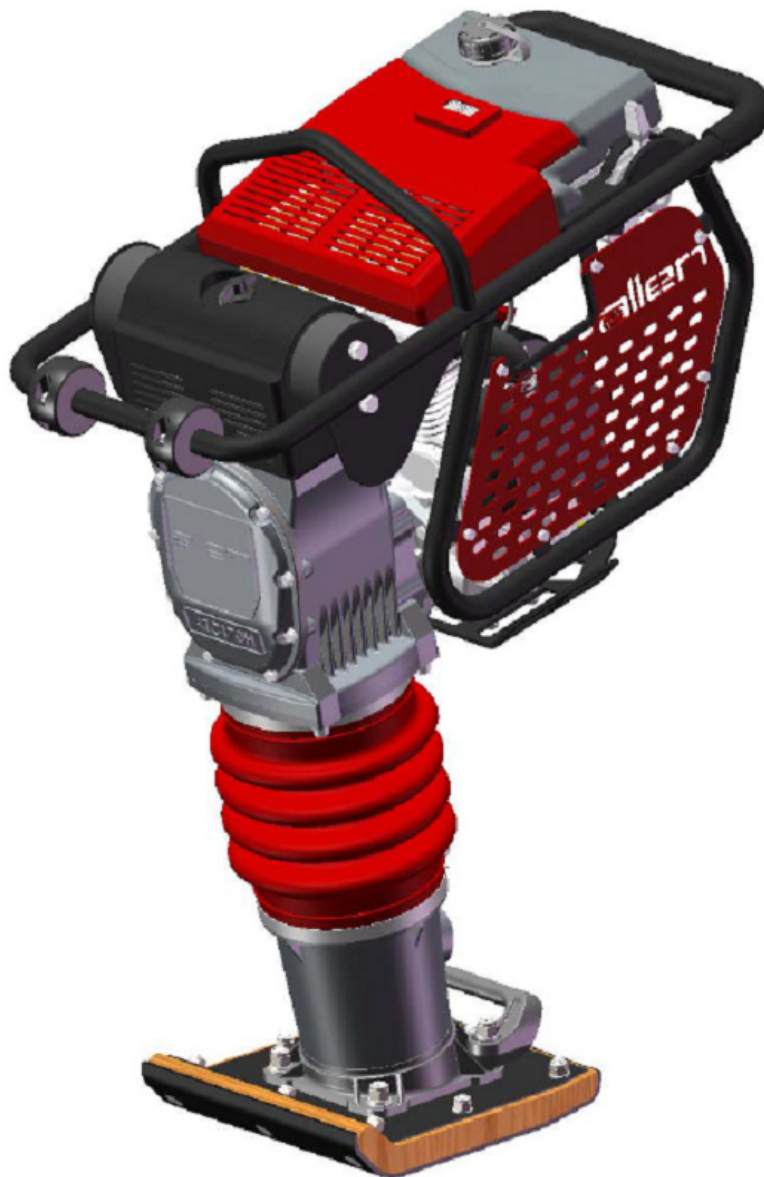

# OPERATIONS - PARTS MANUAL



**ATC130H / ATC170H**  
**Gasoline Rammer**

**allen**  
**ENGINEERING**  
CORPORATION  
819 South 5th Street  
Paragould, AR 72450

## NOTICE

Keep a copy of this manual available with the machine at all times.

# Gasoline Rammer

## OPERATIONS - PARTS

## MANUAL

This manual covers the products listed below:

<u>Part No.</u>	<u>Description</u>
ATC130H	GASOLINE RAMMER (1,390 KGF) GX100
ATC170H	GASOLINE RAMMER (1,600 KGF) GX100

Copyright © 2014 Allen Engineering Corporation  
All rights reserved

All information, specifications, and illustrations in this manual are subject to change without notice and are based on the latest information at the time of publication. No part of this manual may be reproduced or transmitted in any form or by any means, electronic or mechanical, for any purpose, without the express written permission of Allen Engineering Corporation (AEC). AEC assumes no responsibility or liability for any errors or inaccuracies that may appear in this manual.

Allen Products are covered under one or more of the following patent numbers:

**U.S. Design Patents:** 344,736; 400,542; 400,544; 402,998; 402,999; 403,332; 404,041; 404,042; 410,931; 413,127; 416,564; 465,897; 466,909; 474,203.

**U.S. Utility Patents:** 5,108,220; 5,238,323; 5,328,295; 5,352,063; 5,405,216; 5,476,342; 5,480,257; 5,480,258; 5,533,831; 5,562,361; 5,567,075; 5,613,801; 5,658,089; 5,685,667; 5,803,658; 5,816,739; 5,816,740; 5,890,833; 5,934,823; 5,967,696; 5,988,938; 5,988,939; 6,019,433; 6,019,545; 6,048,130; 6,053,660; 6,089,786; 6,106,193; 6,857,815; 5,288,166; 6,582,153 B1, 7,108,449; 7,114,876; 7,316,523; 7,690,864 B2

**Canadian Patents:** 2,039,893.

First Issue: July 2014  
Amended: November 2015

Printed in U.S.A.

# Limited Warranty

Allen Engineering Corporation ("Allen") warrants its products to be free of defects in material or workmanship for:

## **TWO YEARS FROM END USER'S DATE OF PURCHASE**

Warranty period begins on the date of purchase by the End User of the product. All warranty is based on the following limited warranty terms and conditions, including the disclaimer of implied warranties and consequential damages.

1. Allen's obligation and liability under this warranty is limited to repairing or replacing parts if, after Allen's inspection, there is determined to be a defect in material or workmanship. Allen reserves the choice to repair or replace.
2. If Allen chooses to replace the part, it will be at no cost to the customer and will be made available to the Allen Distributor, Dealer, or Rental Center from whom the End User purchased the product.
3. Replacement or repair parts, installed in the product, are warranted only for the remainder of warranty period of the product as though they were the original parts.
4. Allen does not warranty engines or batteries. Engine warranty claims should be made directly to an authorized factory service center for the particular engine manufacturer. Batteries are not warranted due to unknown treatment during transport, etc, and any battery claims should be directed to the battery manufacturer.
5. Allen's warranty does not cover the normal maintenance of products or its components (such as engine tuneups and oil & filter changes). The warranty also does not cover normal wear and tear items (such as belts and consumables).
6. Allen's warranty will be void if it is determined that the defect resulted from operator abuse, failure to perform normal maintenance on the product, modification to product, alterations or repairs made to the product without the written approval of Allen. Allen specifically excludes from warranty any damage to any trowels resulting from an impact to the rotors.
7. Impact damage to gear boxes is not covered under the Allen warranty and is deemed customer abuse.
8. Allen will pay shop labor on warranty items at the Allen Shop Labor Rate in existence on the date of the warranty claim. An Allen labor chart will determine the time allowed to complete a repair and will govern the shop labor hours that will be allowed.
9. Allen will pay freight on warranty replacement parts at worldwide standard ground rates. No warranty replacement parts will be shipped air freight at the expense of Allen. Allen only pays outbound freight charges when sending warranty replacement parts to the customer via ground service. Allen does not pay any inbound freight. However, if Allen determines this to be a warranted item, only then will Allen reimburse the customer for inbound freight at standard ground rates.
10. ALLEN ENGINEERING CORPORATION'S WARRANTY POLICY WILL NOT COVER THE FOLLOWING: TAXES; SHOP SUPPLIES; ENVIRONMENTAL SURCHARGES; AIR FREIGHT; TRAVEL TIME; LOSS OF TIME; INCONVENIENCE; LOSS OF RENTAL REVENUE; RENTAL COSTS OF EQUIPMENT USED TO REPLACE THE PRODUCT BEING REPAIRED; LOSS OF USE OF THE PRODUCT; COMMERCIAL LOSS; OR ANY OTHER CHARGES WHATSOEVER OR ANY LIABILITIES FOR DIRECT, INCIDENTAL, OR CONSEQUENTIAL DAMAGE OR DELAY.
11. ALLEN ENGINEERING CORPORATION MAKES NO OTHER WARRANTY, EXPRESSED OR IMPLIED. THIS LIMITED WARRANTY IS IN LIEU OF THE WARRANTY OF MERCHANTABILITY AND FITNESS. THERE ARE NO OTHER WARRANTIES THAT EXTEND BEYOND THE DESCRIPTION ON THIS DOCUMENT.
12. No Allen employee or representative is authorized to change this warranty in any way or grant any other warranty unless such change is made in writing and signed by an officer of Allen Engineering Corporation.

# Table of Contents

<b>Title</b>	<b>Page</b>
Limited Warranty	4
Table of Contents	5
Information Contained In This Manual	7
Dealer Information	8
Ordering Parts	9
<b>Section 1 - Safety</b>	
Safety Information	10
<b>Section 2 - Operations</b>	
Machine Description	12
Pre-Start Checks	13
Start/Stop Procedure	13
Operation	15
<b>Section 3 - Service</b>	
Service and Maintenance	16
Troubleshooting	18
Technical Data	19

## Table of Contents - Continued

Title	Page
<b>Section 4 - Parts</b>	
ATC130H and ATC170H Fuel Tank and Handle Assembly	20
ATC130H and ATC170H Gear Case and Engine Assembly	22
ATC130H and ATC170H Guide Cylinder & Spring Assembly	24
ATC130H Rammer Shoe Assembly	26
ATC170H Rammer Shoe Assembly	28

# Information Contained in this Manual



This manual provides information and procedures to safely operate and maintain the Allen Machine.

For your own safety and protection from personal injury, carefully read, understand, and observe the safety instructions described in this manual. Keep this manual or a copy of it with the machine at all times.

Always operate this machine in accordance with the instructions described in this manual. A well maintained piece of equipment will provide many years of trouble free operation.

This manual is divided into the following sections:

**SECTION 1  
SAFETY**

**SECTION 2  
OPERATIONS**

**SECTION 3  
SERVICE**

**SECTION 4  
PARTS**

Complete any warranty requirements as specified by the engine manufacturer in their instructions found inside the manual box located on the operator's control panel.

Your engine is not manufactured by Allen Engineering Corporation, Inc, and therefore is not covered under Allen Engineering Corporation, Inc warranty.

Your engine manufacturer should be contacted if you wish to purchase a parts manual or a repair manual for your engine.

Refer to enclosed owners engine manual for complete O&M instructions. See your battery manufacturer for battery warranty.

## Dealer Information

Your Dealer has Allen Engineering Corporation trained mechanics and original Allen replacement parts. Always contact the Allen Dealer who sold you this machine for Allen Certified repairs and replacement parts.

Place Allen Dealer information below for future reference.

Dealer Name:	_____
Phone #:	(____) - ____ - _____
Address:	_____
City:	_____
State:	_____
Zip:	_____
Salesman:	_____
Mobile Phone	_____
Additional Comments:	_____
	_____
	_____





## Ordering Parts

Section 4 contains illustrated parts lists for help in ordering replacement parts for your machine. Follow the instructions below when ordering parts to insure prompt and accurate delivery:

1. All orders for service parts - include the serial number for the machine. Shipment will be delayed if this information is not available.
2. Include correct description and part number from the "PARTS" section of this manual.
3. Specify exact shipping instructions, including the preferred routing and complete destination address.
4. DO NOT return parts to AEC without receiving written authorization from AEC. All authorized returns must be shipped pre-paid.
5. When placing an order, please contact the AEC dealer nearest you.

### **NOTE**

*All information, specifications, and illustrations in this manual are subject to change without notice and are based on the latest information at the time of publication.*

VISIT US!!!



[www.alleneng.com](http://www.alleneng.com)

LIKE US!!!



[www.facebook.com/AllenEngineering](http://www.facebook.com/AllenEngineering)

FOLLOW US!!!



[@alleneng](https://twitter.com/alleneng)

WATCH US!!!



[www.youtube.com/AllenMachinery](http://www.youtube.com/AllenMachinery)

## SECTION 1 SAFETY

## Safety Information



This CAUTION sign indicates a potential hazard, which if ignored could result in injuries to the operator and/or those close by, as well as damaging the machine.



This WARNING sign indicates a potential hazard, which if ignored could result in the DEATH of the operator and/or those close by.

For your own personal protection and for the safety of those around you, please read and ensure you fully understand the following safety information. It is the responsibility of the operator to ensure that he/she fully understands how to operate this equipment safely. If you are unsure about the safe and correct use of the Vibratory Plate Compactor, consult your supervisor or ALLEN.



Improper maintenance can be hazardous. Read and understand this section before you perform any maintenance, service or repairs.

### General Safety

- This machine is heavy and must not be lifted single-handedly; either get help or use suitable lifting equipment.
- This machine is to be used for its intended application only.
- This machine must only be operated by well-trained personnel.
- The owner of this machine must observe, and train the user to observe, the effective laws of labour protection in the country of application.
- Personal Protective Equipment (PPE) must be worn by the operator whenever the equipment is being used.
- Cordon off the work area and keep members of the public and unauthorised personnel at a safe distance.
- This machine must be operated on ground where stability is guaranteed. When working near the rim of excavated trenches, use the machine properly so that the machine may not fall down or collapse the excavation.
- Make sure you know how to safely switch this machine OFF before you switch it ON in case you run into any difficulties.
- Always switch OFF the engine before servicing it.
- During use, the engine becomes very hot. Always allow the engine to cool down before touching it.
- Never leave the engine running and unattended.
- Never remove or tamper with any fitted guards; they are there for your own protection. If they are damaged or missing, DO NOT USE THE MACHINE until the guard has been replaced or repaired.
- Always switch OFF the engine before transporting it, moving it around site or servicing it.
- Do not operate the machine when you are ill, feeling tired or when under the influence of alcohol or drugs.

- This machine is designed to eliminate the possible risks arising from the use of it. However, risks DO reside, and these residual risks are not clearly recognisable and may cause personal injury or property damage, and possibly death. If such unpredictable and unrecognisable risks become apparent, the machine must be stopped immediately, and operator or his supervisor must take appropriate measure to eliminate such risks. It is sometimes necessary that the manufacturer must be informed of such event for future counter measuring.

### Fuel Safety



Fuel is flammable. It may cause injury and property damage. Shut down the engine, extinguish all open flames and do not smoke while filling the fuel tank. Always wipe up any spilled fuel.

- Before re-fuelling, switch off the engine and allow it to cool.
- When re-fuelling, use a proper funnel, and avoid spilling over the engine.
- When re-fuelling, DO NOT smoke or allow naked flames in the area.
- Spilt fuel must be made safe immediately by using sand. If fuel is spilt on your clothes, change them.
- Store fuel in an approved, purpose made container away from heat and sources of ignition.

### Health & Safety

#### ***Vibration***

Some vibration from the compacting operation is transmitted through the handle to the operator's hands. Ensure operator rotation and do not exceed the maximum recommended usage times.

#### ***Dust***

The compaction process can produce dust, which may be hazardous to your health. Always wear a mask that is suited to the type of dust being produced.

#### ***Fuel***

Do not ingest fuel or inhale fuel vapors and avoid contact with your skin. Wash fuel splashes immediately. If you get fuel in your eyes, irrigate with copious amounts of water and seek medical attention as soon as possible.



The exhaust fumes produced by this machine are highly toxic and can kill!

#### ***Exhaust Fumes***

Do not operate the Rammer indoors or in confined spaces. Make sure the work area is adequately ventilated.

## SECTION 2 OPERATIONS

## Operations

### Machine Description

#### *Intended Use*

This machine is intended for base preparation, driveways, foundations, curbs, and footings. It can also be used for repair work on streets, highways and/or pavements/sidewalks.

### ATC130H / ATC170H

1. Oil Plug/Site Glass
2. Engine
3. Throttle Lever
4. Operating Handle
5. Fuel Tank
6. Lifting Point
7. Fuel ON/OFF Lever
8. Primary Air Cleaner
9. Crankcase
10. Bellow
11. Ramming Shoe/Foot

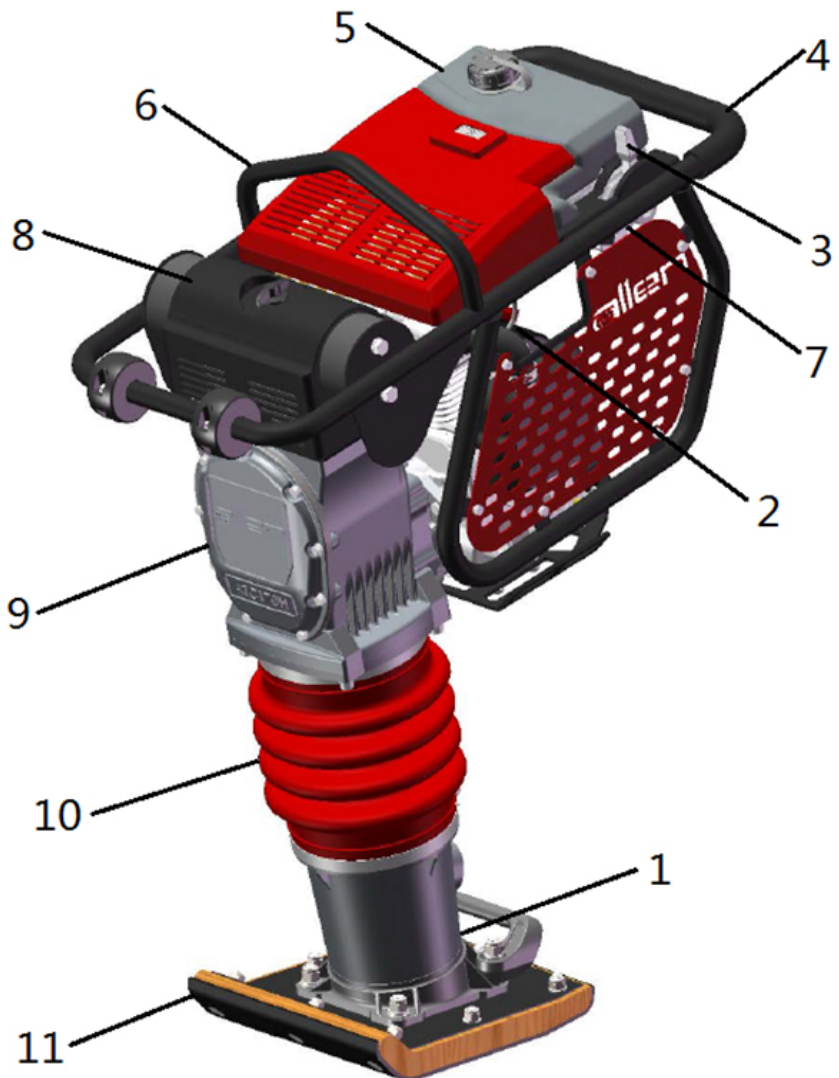

### Pre-start Checks

The following pre-start checks must be performed before the start of each work session or after every four hours of use, whichever is first. Please refer to the Service and Maintenance section for detailed guidance. If any fault is discovered, the Plate Compactor must not be used until the fault is rectified.

1. Thoroughly inspect the machine for signs of damage, Make sure all guards are in place and secured.
2. Check hoses, filler openings, drain plugs and other areas for signs of leakage. Fix any leaks before operating.
3. Check the engine oil level and top up as necessary. Use proper engine oil with the proper viscosity (SAE 10W-30 is recommended).
4. Check the engine fuel level and top us as necessary. Use clean fuel. The use of contaminated fuel may damage the fuel system.



This machine uses unleaded petrol/gasoline!!

5. Check the air filter is clean. Excessive dirt/dust accumulation within the filter element will cause erratic engine operation. Clean the air filter element when it is contaminated (refer to the Service and Maintenance section).
6. Check for fuel and oil leaks.

### Start/Stop Procedure

1. Open the fuel cock.
2. Set the engine switch to the ON position.
3. Set the speed control lever to the STARTING position (Halfway between HIGH and LOW position).
4. Move the choke lever to the CLOSED position.
5. Taking a firm hold of the Operating handle with one hand, grasp the recoil starter handle with the other, Pull the recoil starter handle until engine resistance is felt, then let starter return.
6. Taking care not to pull the starter rope fully out, pull the starter handle briskly.
7. Repeat until the engine fires.
8. Once the engine fires gradually set the choke lever to the OPEN position.
9. Let the engine run at idle for a few minutes to warm up.
10. After the engine has warmed up, the machine is ready for operation.
11. Move the throttle lever to the high speed 'H' position quickly to prevent damage from occurring to the clutch. The 'Full Throttle' position of this machine has been preset at the factory to achieve optimum machine performance.
12. With the engine running in the full throttle position, the machine will move forward and compact loose 'lifts'.
13. In preparation for stopping the engine, move the throttle lever to the LOW position.

## SECTION 2 OPERATIONS

### Operations (cont'd)

14. Allow the engine to idle for 1-3 minutes.
15. Set the engine switch to the OFF position. Do not touch the HOT engine part at this time.
16. Close the fuel cock.
17. Pull the recoil starter slowly until you feel resistance. Then release your hand from the starter knob to set it back to its original position. This will prevent any air or humidity from entering into the cylinder.

Model	Engine	Maximum RPM	
		Optimum	Upper Limit
ATC130H/ATC170H	HONDA GX100	3700~3800	4100

The Max rpm as shown above is the number of ignitions per minute. The number of ignitions per minute is different from the number of rotations of the engines Power Take-Off Shaft.



DO NOT alter this setting since irregular vibration or damage to the gear transmission mechanism can result, and both engine and machine warranties will be automatically voided.

Having carried out the check in the 'Pre-Start' section, you may now start the engine.



### Operation

This machine is fitted with a centrifugal clutch. This allows the engine to run at idle without driving the power transmission gears. As the engine speed is increased, the clutch will engage and the engine will drive the power transmission gears.

- To avoid damage to the centrifugal clutch, move the throttle lever quickly from the L to H position. For correct operation, the engine speed should be set to maximum.
- Avoid operating the machine on a fully compacted, hard, or non-yielding surface. Otherwise, the power transmission gears will be damaged and the life of the machine will be greatly reduced.
- When working in a narrow trench, if the ramming shoe should get caught between the walls of the trench, the rammer may miss-strike and can be severely damaged. The ramming shoe may especially be damaged severely.
- Be sure that the rammer is steered only with the handle. It should only be pushed. The rammer must not be pressed into the materials being compacted. Excessive pressure on the operating handle will lead to the unsatisfactory compaction due to the fact that the jumping action is hindered.

### Operation at High Altitude

For continuous High-Altitude operation above 1,000m (3,000FT), it will be necessary to change the engine main jet to a type that will allow for correct fueling of the engine. Otherwise, the unit will suffer from a lack of engine power and not work correctly. Please contact dealers for details.

## **SECTION 3 SERVICE**

# **Service**

### **Service and Maintenance**

The Rammers are designed to give many years of trouble free operation. It is, however, important that the simple regular maintenance listed in this section is carried out. It is recommended that an approved dealer carry out all major maintenance and repairs. Always use genuine Allen replacement parts, the use of spurious parts may void your warranty.

Before any maintenance is carried out on the machine, switch off the engine and disconnect the HT lead from the spark plug. Always set the machine on level ground to ensure any fluid levels will be correctly read. Only use recommended oils.

### **Servicing the Engine**

Service the engine according to the engine manufacturer's specifications. Refer to the engine operation and maintenance manual.

#### **Maintenance: Every 8 hours or daily**

1. Check for loose bolts and nuts, retighten if necessary.
2. Check and clean the air filter element, re-lube the element in accordance with the engine manufacturer's recommendations. If operating conditions are unusually dusty and severe, filter element cleaning should be done more frequently.
3. Check oil level in crankcase of engine and replenish as necessary. Check the oil level in the ramming cylinder according to the following procedures:
  - Make sure that the machine has not been run in the last 10 minutes.
  - Set the machine on a level surface and remove the oil plug.
  - The top surface of the oil must be seen just below the lower rim of the hole on the oil sight glass. Replenish as necessary.

**NOTICE:** Care should be taken not to overfill/over pump the rammer with oil/grease. Overfilling will cause excessive load on the engine, which may result in poor or irregular vibration.

#### **Maintenance: Every 50 hours or weekly**

Check for loose bolts and nuts. Retighten if necessary.

#### **Maintenance: Every 200 hours**

Check the ramming cylinder oil. Do not overfill.



## Fuel, Lubricant

Model	Fuel		Engine Crankcase			Ramming Cylinder	
	Type	Capacity	Type	Engine	Capacity	Type	Capacity
ATC130H	Unleaded Gasoline	3.8L	SAE 10W – 30, API, SG, SF/CC,	GX100	0.30L	SAE 10W – 30, API, SG, SF/CC,	0.5L
ATC170H			CD			CD	

## Transportation and Storage

### Lifting

Where it is necessary to use lifting equipment to position the rammer, check and confirm that the rubber isolators on the operation handle is not damaged or cracked. If they are cracked or damaged, replace the rubber isolators before attempting to lift the machine. Also make sure that the lifting equipment has a WLL (Working Load Limit) suitable for the rammer's weight (See specification chart on page 19 or the machine number plate). Attach suitable chains or slings ONLY to the lifting point on top of the rammer's operating handle.

- NEVER leave the engine running whilst transporting or moving the rammer, even if it is only a short distance.
- The height of the operating handle can be adjusted within the range of 850 ~ 880 mm. Loosen three bolts at each side of the operating handles base, and retighten them at the desired handle height. Note that when the handle is set too high, excessive vibration may be transmitted through the handle.

### On Site Transport

The rammer may be moved vertically by 2 people, or laid only on the Transport Rollers.

### Road Transport

The rammer must be transported as far as possible standing up, strapped to the body side board of the truck, or strapped inside a lorry (panel truck). If not possible, it may be laid down (engine facing upwards, not on its sides) only on the Transport Rollers, in a stable position and strongly strapped down to guard against rolling or sliding.



Wait until the unit is completely cool before laying it down.

## SECTION 3 SERVICE

### Service (cont'd)

#### Long-term Storage

The chemical composition of the fuel will deteriorate after prolonged storage. When the machine needs to be stored for a long time, remove all the fuel from the fuel tank. You can achieve this by running the engine with the fuel tap being closed. Also remove the fuel from the drain plug.

Clean up oil and dust accumulation on rubber parts.

Clean the base plate and apply a light coating of oil to prevent rust formation.

Cover the machine and store in a dry place.

#### Troubleshooting

Problems	Possible Causes	Countermeasures
Engine will not start	<ol style="list-style-type: none"> <li>1. No fuel.</li> <li>2. Fuel tap has been closed.</li> <li>3. Engine turned off.</li> <li>4. Contaminated/damaged spark plug.</li> <li>5. Faulty carburetor</li> </ol>	<ol style="list-style-type: none"> <li>1. Fill fuel tank.</li> <li>2. Open fuel tap.</li> <li>3. Turn engine ON.</li> <li>4. Replace spark plug.</li> <li>5. Service the carburetor.</li> </ol>
Engine stops suddenly or stops when the engine rpm is increased	<ol style="list-style-type: none"> <li>1. See above</li> <li>2. Main jet of the carburetor clogged with dirt.</li> <li>3. Air filter element dirty.</li> <li>4. Spark plug cap is loose</li> </ol>	<ol style="list-style-type: none"> <li>1. See above.</li> <li>2. Take out main jet of the carburetor and clean with an air gun.</li> <li>3. Clean the element.</li> <li>4. Tightly fit cap to the plug.</li> </ol>
Engine runs but unit does not produce impact	<ol style="list-style-type: none"> <li>1. Lack of engine power.</li> <li>2. Clutch is slipping.</li> <li>3. Power transmission gears are damaged.</li> </ol>	<ol style="list-style-type: none"> <li>1. See above</li> <li>2. Dismantle clutch assembly, clean shoe and drum with proper solvent. Replace clutch shoe if necessary.</li> <li>3. Contact dealer.</li> </ol>

MODEL	ATC130H	ATC170H
DIMENSION (LxWxH)	735x370x1035	735x370x1,070
OPERATING WEIGHT - KG	69	79
SHOE SIZE (LxW)	340x275	340x285
STROKE - mm	50-70	50-70
IMPACT FORCE - KGF (KN)	1,390 (14)	1,600 (16)
BLOWS PER MINUTE (bpm)	650 -700	650 -700
COMPACTION DEPTH (DEPENDING ON SOIL) - mm	610	610
TRAVEL SPEED - m/min	13-Oct	13-Oct
COMPACTED AREA - m <sup>2</sup> /h	260	260
FUEL TANK CAPACITY- Ltr	3.5	3.5
ENGINE	HONDA GX100	HONDA GX100
ENGINE TYPE	Air-cooled single-cylinder 4-stroke Gasoline Engine	Air-cooled single-cylinder 4-stroke Gasoline Engine
POWER OUTPUT - hp (Kw)	3.0 (2.2) / 3600RPM	3.0 (2.2) / 3600RPM

# SECTION 4 PARTS

## ATC130H / ATC170H Fuel Tank and Handle Assembly - Illustration

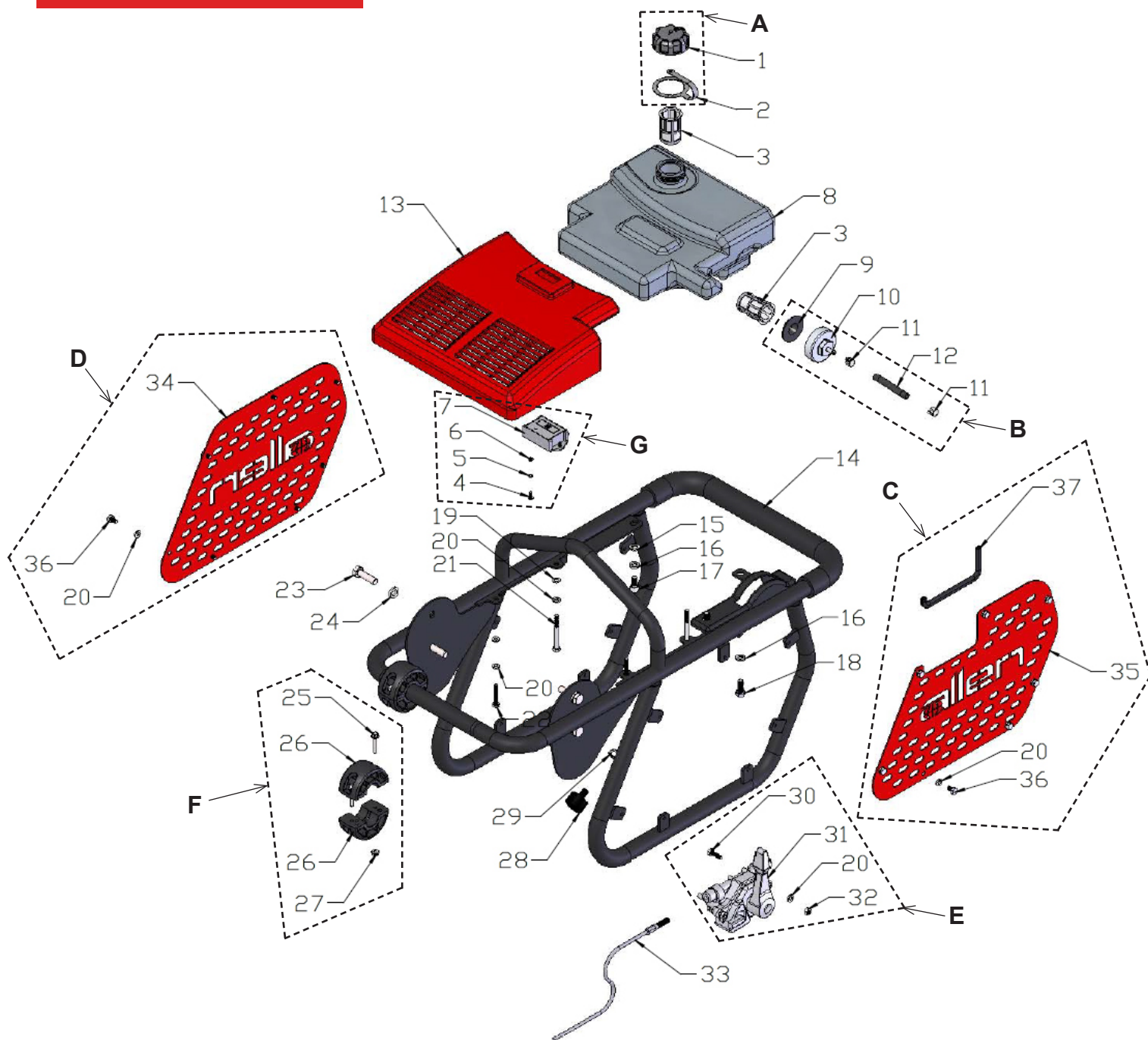

# ATC130H / ATC170H Fuel Tank and Handle Assembly - Parts List

## SECTION 4 PARTS

NO.	PART NO.	PART DESCRIPTION	QTY
01-1	A - 064851	FUEL TANK CAP	1
01-2		STRAP	1
01-3	061796	STRAINER	2
01-4	G - 064852	FSTN, PAN HEAD SCREW M4x10	2
01-5		FSTN, LW W4-DIN-2	2
01-6		FSTN, FW W4-DIN-2	2
01-7		TACHOMETER	1
01-8	061801	FUEL TANK	1
01-9	B - 064861	PACKING	1
01-10		FUEL TANK CAP ,BOTTOM	1
01-11		HOSE BAND	2
01-12		FUEL HOSE	1
01-13	061806	COVER	1
01-14	061807	OPERATION HANDLE	1
01-15	061808	FSTN, FW W8-DIN-1	3
01-16	061809	FSTN, LW W8-DIN-1	4
01-17	061810	FSTN, SCREW M8x16-8.8-GB-1	3
01-18	061811	FSTN, HHCS FN.B-M8x20-8.8-DIN-1	1
01-19	061812	FSTN, FW W6-DIN-1	4
01-20		FSTN, LW W6-DIN-1	20
01-21	061814	FSTN, HHCS M6x60-8.8HALF-DIN-1	2
01-22	061815	FSTN, HHCS M6x35-8.8-DIN-1	2
01-23	061816	FSTN, HHCS M10x35-8.8-DIN-1	4
01-24	061817	FSTN, LW W10-DIN-1	4
01-25	F - 064853	FSTN, HHCS M5x20-8.8-DIN-3	4
01-26		ROLLER	4
01-27		FSTN, HEX NUT M5-DIN-3	4
01-28	061821	CUSHION	1
01-29	061822	FSTN, LOCK NUT M10-DIN-1	1
01-30	E - 064854	FSTN, HHCS M6x20-8.8-DIN-1	2
01-31		THROTTLE LEVER ASSY	1
01-32		FSTN, NUT M6-DIN-1	2
01-33	061826	THROTTLE CABLE	1
01-34	C - 064856	RIGHT COVER	1
01-20		FSTN, LW W6-DIN-1	7
01-36		FSTN, HHCS M6x10-8.8-DIN-1	7
01-35		LEFT COVER	1
01-20	D - 064855	FSTN, LW W6-DIN-1	7
01-36		FSTN, HHCS M6x10-8.8-DIN-1	7
01-37		EDGE PROTECTOR	1

# SECTION 4 PARTS

## ATC130H Gear Case and Engine Assembly Illustration

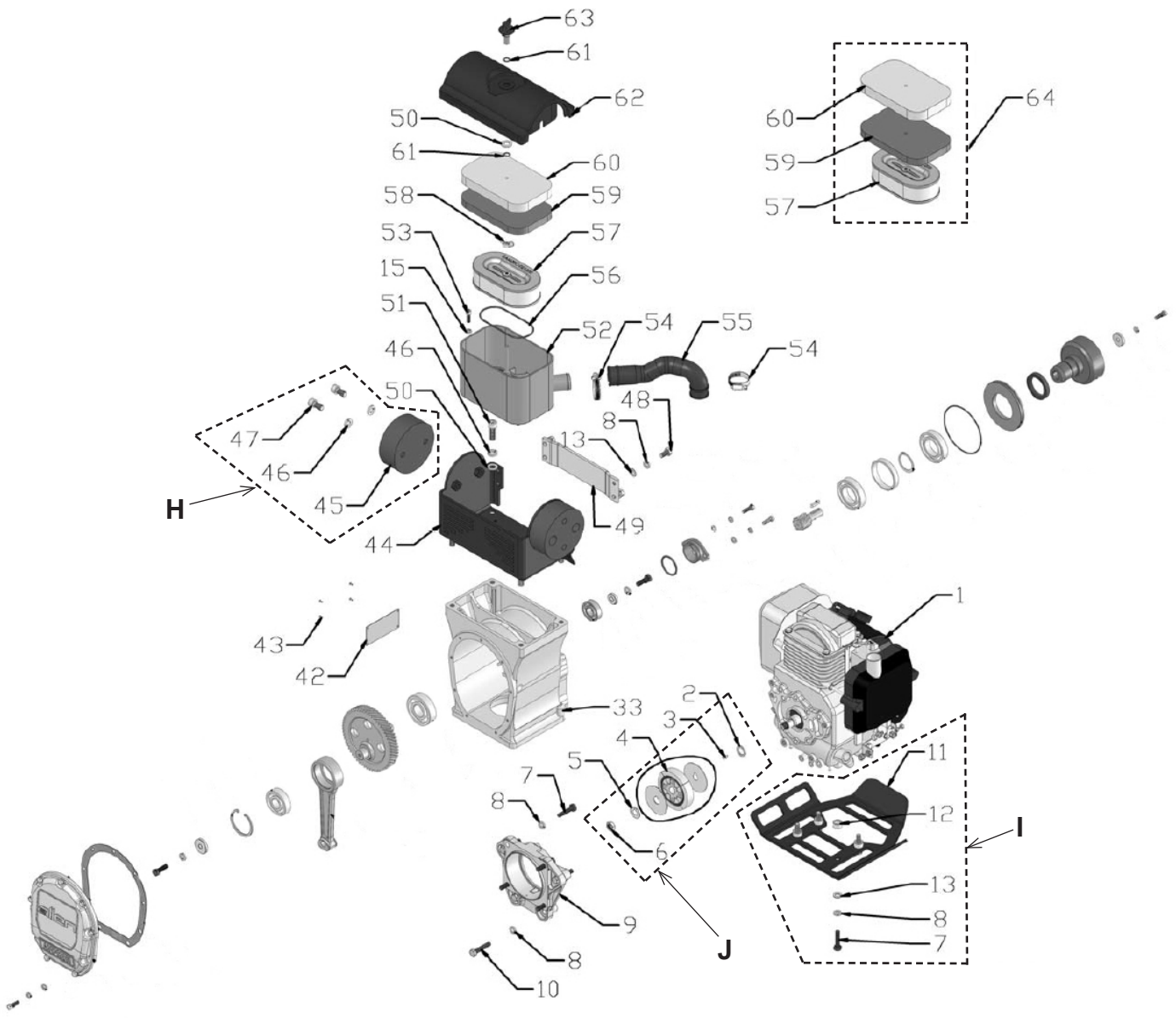

# ATC130H Gear Case and Engine Assembly Parts List

## SECTION 4 PARTS

NO.	PART NO.	PART DESCRIPTION	QTY
02-1	061831	ENGINE	1
02-2	<b>J</b> - 064859	FSTN, WASHER 80-0997	1
02-3		WOODRUFF KEY, 4x5x13	1
02-4		CENTRIFUGAL CLUTCH ASSY	1
02-5		FSTN, LW 80-0998	1
02-6		FSTN, THIN NUT M12x1.25-DIN-2	1
02-7	061837	FSTN, HHCS M8x35-8.8-DIN-1	8
02-8	061838	FSTN, LW W8-DIN-1	18
02-9	061839	FLANGE	1
02-10	061840	FSTN, HHCS M8x40-8.8-DIN-1	4
02-11	<b>I</b> - 064858	ENGINE SUPPORT	1
02-12		FSTN, WASHER 276-040200	4
02-13		FSTN, WASHER W8-DIN-1	8
02-33	064860	GEARBOX ASSEMBLY	1
02-42	061872	NAMEPLATE	1
02-43	061873	RIVET	4
02-44	061874	HANDLE SUPPORT	1
02-45	<b>H</b> - 064857	SHOCK ABSORBER	2
02-46		FSTN, LW W10-DIN-1	8
02-47		FSTN, SCREW M10x20-8.8-GB-1	4
02-48	061878	FSTN, HHCS M8x16-8.8-DIN-1	4
02-49	061879	FIXING PLATE	1
02-50	061880	FSTN, WASHER W10-DIN-1	5
02-51	061881	FSTN, SCREW M10x30-8.8-GB-1	4
02-52	061882	AIR CLEANER BOX	1
02-53	061883	FSTN, SCREW M6x20-8.8-GB-1	4
02-54	061884	HOOP	2
02-55	061885	INTAKE PIPE	1
02-56	061886	O-RING, W04-90x3.5	1
02-57	061887	FILTER	1
02-58	061888	FSTN, WING NUT M6	1
02-59	061889	SECOND AIR CLEANER	1
02-60	061890	FIRST AIR CLEANER	1
02-61	061891	O-RING, W04-8.8x1.9	2
02-62	061892	AIR CLEANER BOX COVER	1
02-63	061893	FSTN, SCREW, 70C-020900	1
02-64	061894	AIR CLEANER GROUP	1

# SECTION 4 PARTS

## ATC130H Guide Cylinder & Spring Ass'y Illustration

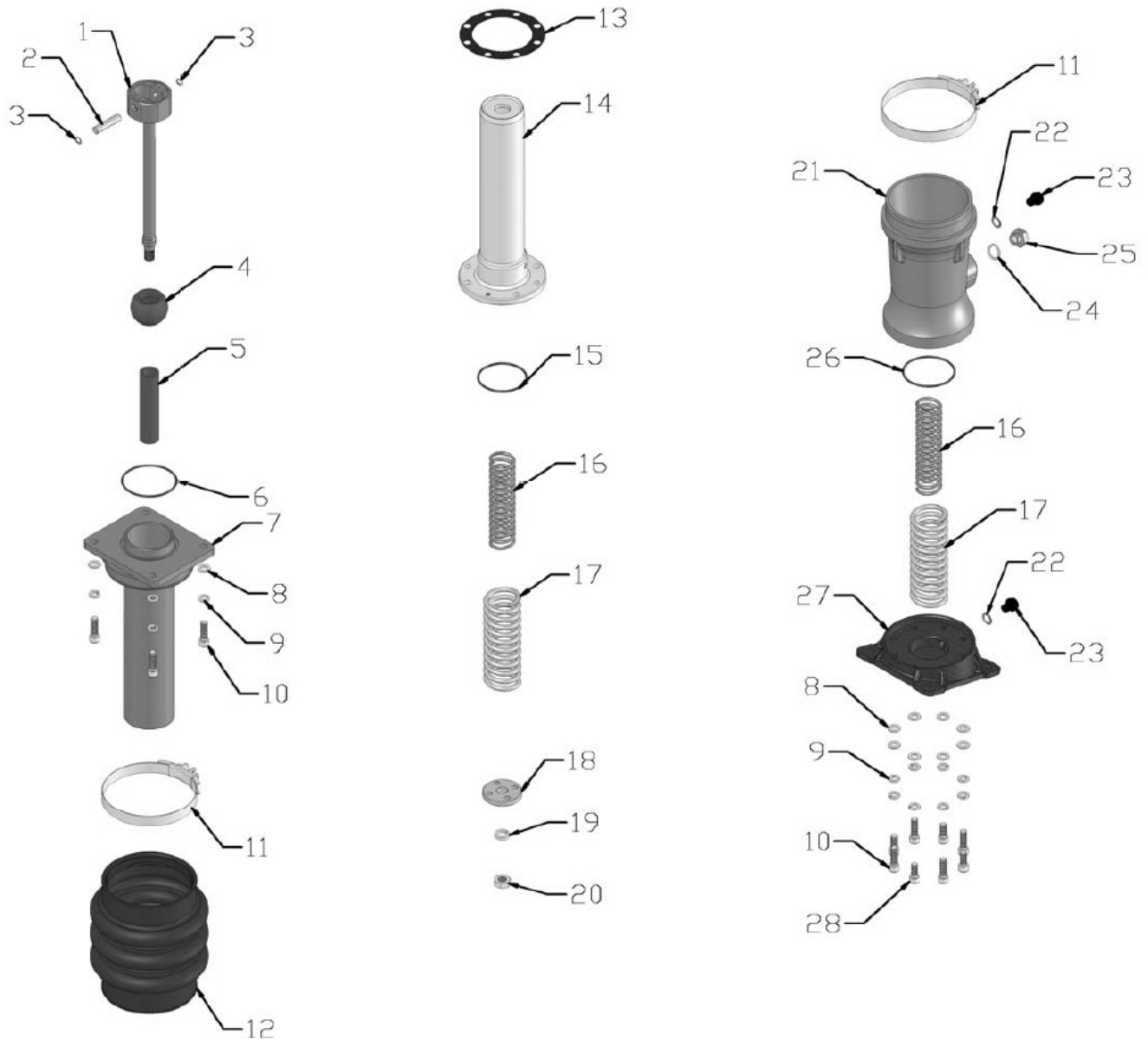



# ATC130H Guide Cylinder & Spring Ass'y Parts List

## SECTION 4 PARTS

NO.	PART NO.	PART DESCRIPTION	QTY
03-1	061895	PISTON ROD	1
03-2	061896	PISTON PIN	1
03-3	061897	INTERNAL CIRCLIP	2
03-4	061898	STOPPER	1
03-5	061899	SPRING GUIDE	1
03-6	061900	O-RING, W04-84.4x3.1	1
03-7	061901	GUIDE CYLINDER	1
03-8	061880	FSTN, WASHER W10-DIN-1	12
03-9	061817	FSTN, LW W10-DIN-1	12
03-10	061816	FSTN, HHCS M10x35-8.8-DIN-1	8
03-11	061905	BELLOW HOOP	2
03-12	061906	BELLOW	1
03-13	061907	PACKING	1
03-14	061908	SPRING CYLINDER	1
03-15	061909	O-RING, W04-74.4x3.1	1
03-16	061910	INNER SPRING	2
03-17	061911	OUTTER SPRING	2
03-18	061912	PISTON	1
03-19	061913	FSTN, LW W16-DIN-1	1
03-20	061914	FSTN, NUT 50ND-030010	1
03-21	061915	PROTECTION SLEEVE	1
03-22	061916	CUPRUM WASHER	2
03-23	061917	HEXAGON HEAD PLUG	2
03-24	061918	FSTN, WASHER ZH-D-M20	1
03-25	061919	OIL GAUGE	1
03-26	061920	O-RING, W04-79.4x3.1	1
03-27	061921	FOOT PLATE	1
03-28	061922	SCREW	4

# SECTION 4 PARTS

## ATC130H Rammer Shoe Assembly Illustration

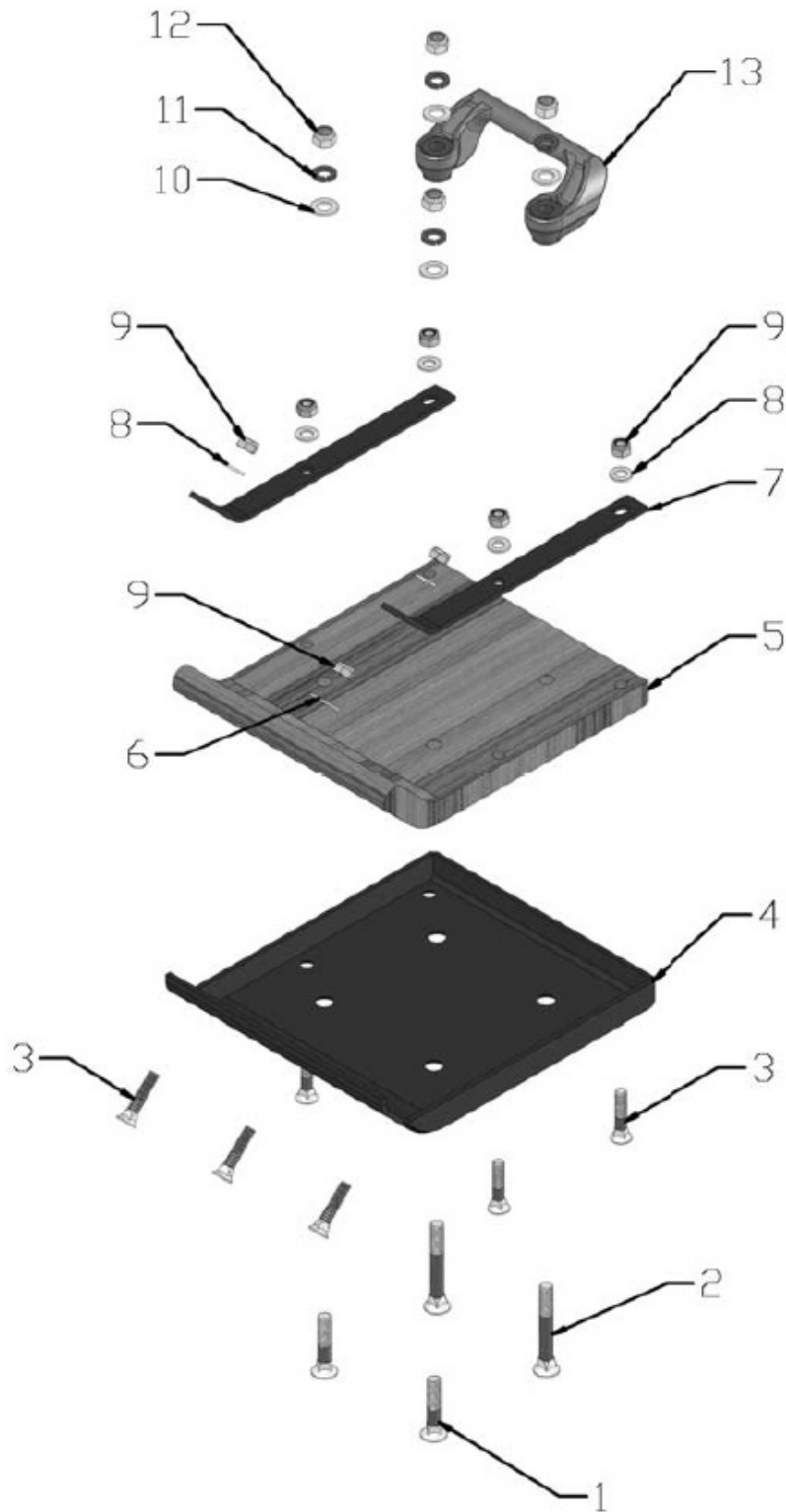

# ATC130H Rammer Shoe Assembly Parts List

## SECTION 4 PARTS

NO.	PART NO.	PART DESCRIPTION	QTY
04-1	061923	FSTN, FHSCS M12x60	2
04-2	061924	FSTN, FHSCS M12x90	2
04-3	061925	FSTN, FHSCS M10x50	7
04-4	061926	RAMMER SHOE STEEL PLATE	1
04-5	061927	RAMMER SHOE WOODEN PLATE	1
04-6	061928	FSTN, WASHER W10-GB-1	1
04-7	061929	RAMMER SHOE CLAMP PLATE	2
04-8	061880	FSTN, WASHER W10-DIN-1	6
04-9	061822	FSTN, LOCK NUT M10-DIN-1	7
04-10	061932	FSTN, WASHER W12-DIN-1	4
04-11	061933	FSTN, LW W12-DIN-1	4
04-12	061934	FSTN, LOCK NUT M12-DIN-1	4
04-13	061935	HANDLE	1

# SECTION 4 PARTS

## ATC170H Gear Case and Engine Assembly Illustration

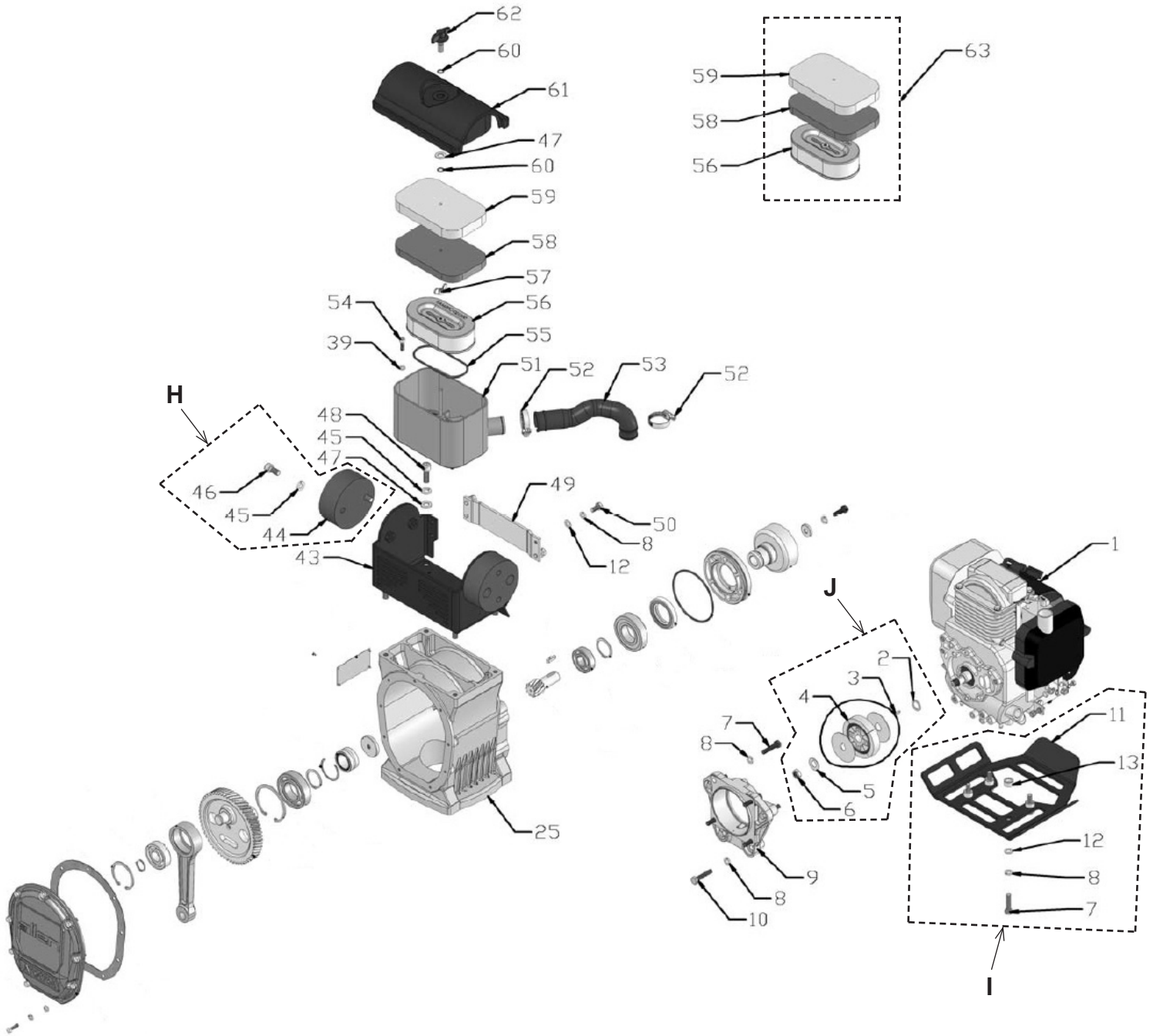

# ATC170H Gear Case and Engine Assembly Parts List

## SECTION 4 PARTS

NO.	PART NO.	PART DESCRIPTION	QTY
02-1	061831	ENGINE	1
02-2	<b>J</b> - 064859	FSTN, WASHER 80-0997	1
02-3		WOODRUFF KEY, 4x5x13	1
02-4		CENTRIFUGAL CLUTCH ASSY	1
02-5		FSTN, LW 80-0998	1
02-6		FSTN, THIN NUT M12x1.25-DIN-2	1
02-7	061837	FSTN, HHCS M8x35-8.8-DIN-1	8
02-8	061838	FSTN, LW W8-DIN-1	17
02-9	061839	FLANGE	1
02-10	061840	FSTN, HHCS M8x40-8.8-DIN-1	4
02-11	<b>I</b> - 064858	ENGINE SUPPORT	1
02-12		FSTN, WASHER 276-040200	8
02-13		FSTN, WASHER W8-DIN-1	4
02-25	064864	GEAR CASE	1
02-43	061874	HANDLE SUPPORT	1
02-44	<b>H</b> - 064857	SHOCK ABSORBER	2
02-45		FSTN, LW W10-DIN-1	8
02-46		FSTN, SCREW M10x20-8.8-GB-1	4
02-47	061880	FSTN, WASHER W10-DIN-1	5
02-48	061881	FSTN, SCREW M10x30-8.8-GB-1	4
02-49	061879	FIXING PLATE	1
02-50	061878	FSTN, HHCS M8x16-8.8-DIN-1	4
02-51	061882	AIR CLEANER BOX	1
02-52	061884	HOOP	2
02-53	061885	INTAKE PIPE	1
02-54	061883	FSTN, SCREW M6x20-8.8-GB-1	4
02-55	061886	O-RING, W04-90x3.5	1
02-56	061887	FILTER	1
02-57	061888	FSTN, WING NUT M6	1
02-58	061889	SECOND AIR CLEANER	1
02-59	061890	FIRST AIR CLEANER	1
02-60	061891	O-RING, W04-8.8x1.9	2
02-61	061892	AIR CLEANER BOX COVER	1
02-62	061893	FSTN, SCREW, 70C-020900	1
02-63	061894	AIR CLEANER GROUP	1

# SECTION 4 PARTS

## ATC170H Guide Cylinder & Spring Ass'y Illustration

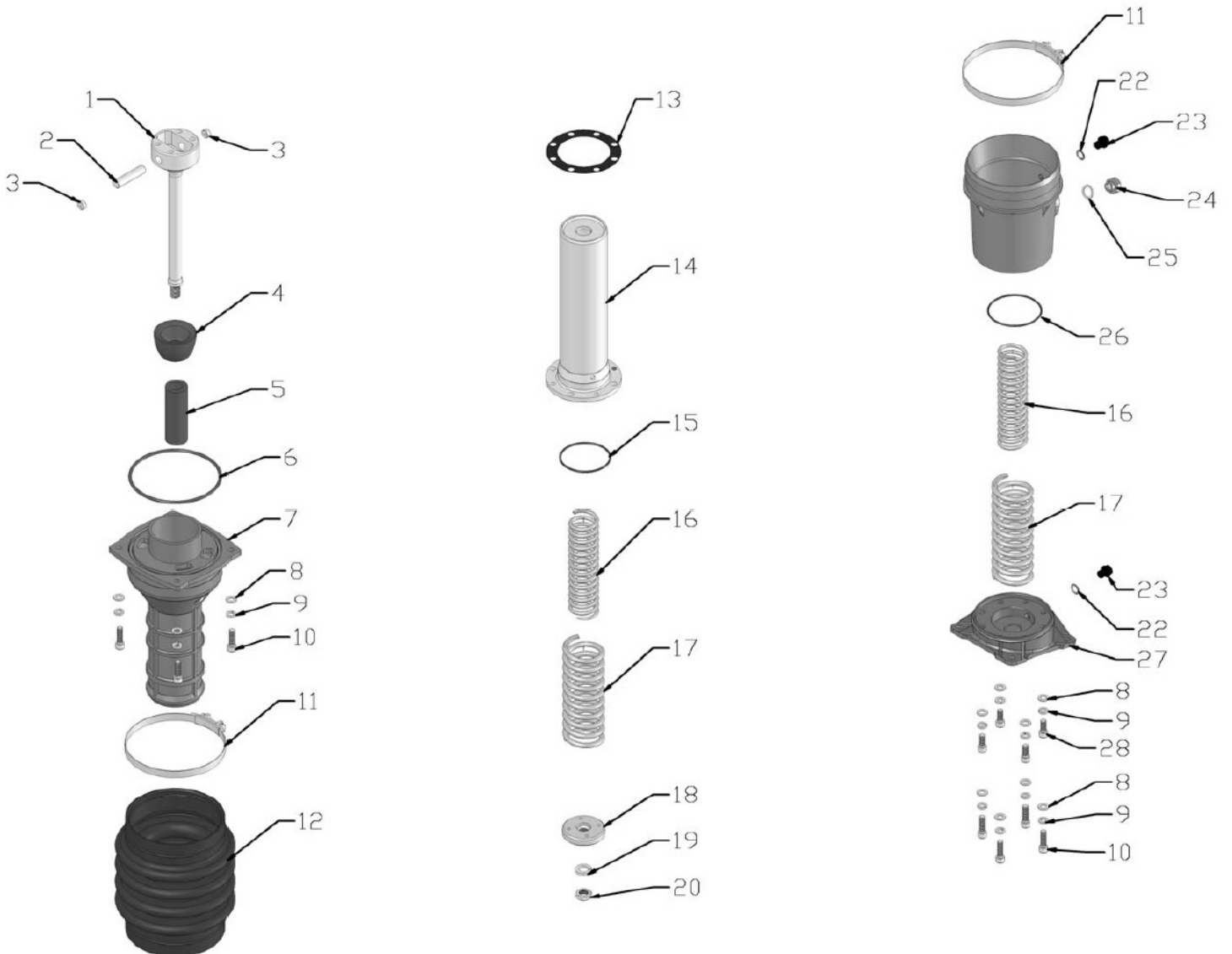

# ATC170H Guide Cylinder & Spring Ass'y Parts List

## SECTION 4 PARTS

ITEM	PART #	DESCRIPTION	QTY
03-1	062498	PISTON ROD	1
03-2	062499	PISTON PIN	1
03-3	062500	NYLON STOPPLE	2
03-4	062501	STOPPER	1
03-5	062502	SPRING GUIDE	1
03-6	062503	O RING	1
03-7	062504	GUIDE CYLINDER	1
03-8	062505	WASHER	12
03-9	062506	SPRING WASHER,TANG ENDS	12
03-10	062507	SCREW	8
03-11	062508	BELLOW HOOP	2
03-12	062509	BELLOW	1
03-13	062510	PACKING	1
03-14	062511	SPRING CYLINDER	1
03-15	062512	O RING	1
03-16	062513	INNER SPRING	2
03-17	062514	OUTER SPRING	2
03-18	062515	PISTON	1
03-19	062516	SPRING WASHER	1
03-20	062517	THIN NUT	1
03-21	062518	PROTECTION SLEEVE	1
03-22	062519	CUPRUM WASHER	2
03-23	062520	HEXAGON HEAD PLUG	2
03-24	062521	OIL GAUGE	1
03-25	062522	WASHER	1
03-26	062523	O RING	1
03-27	062524	FOOT PLATE	1
03-28	062525	SCREW	4

# SECTION 4 PARTS

## ATC170H Rammer Shoe Assembly Illustration

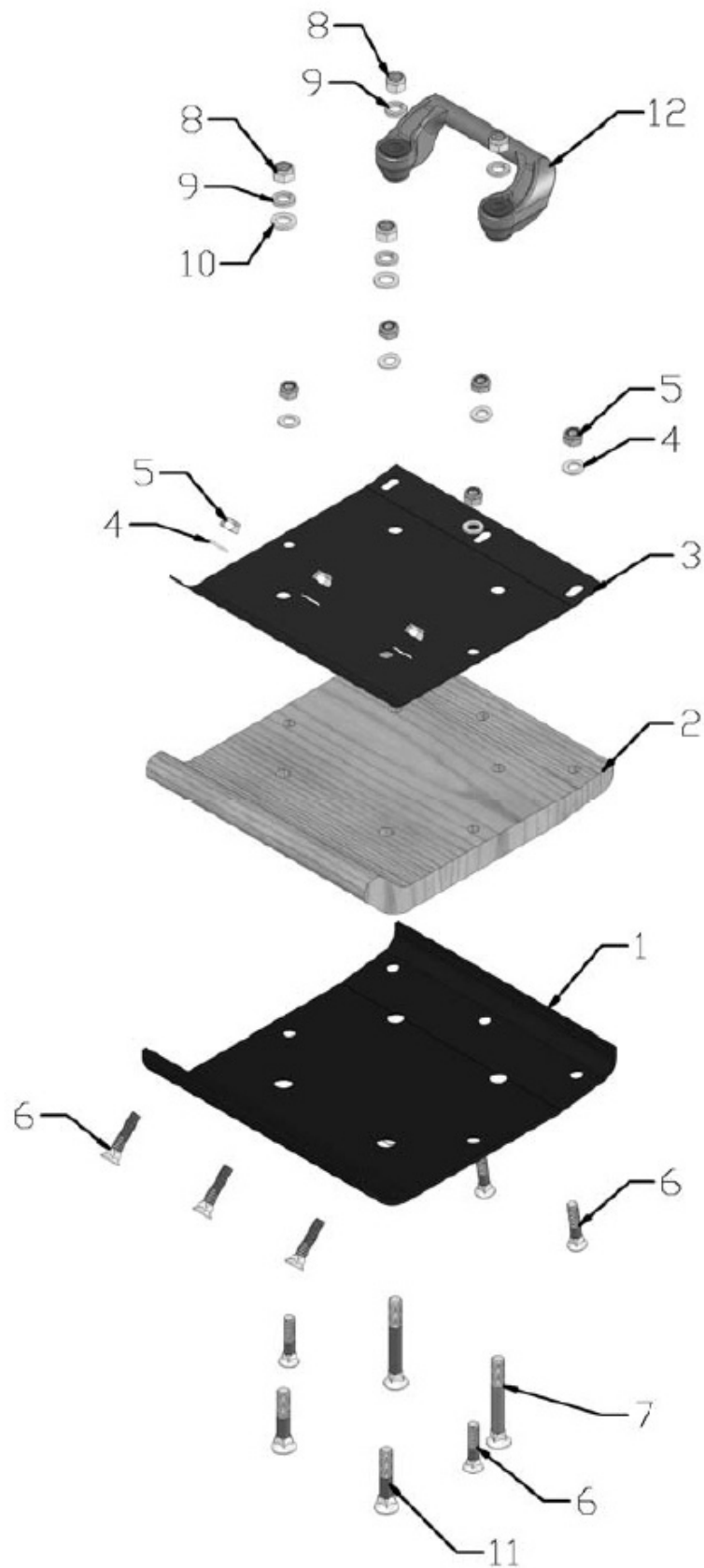



# ATC170H Rammer Shoe Assembly Parts List

## SECTION 4 PARTS

NO.	PART NO.	PART DESCRIPTION	QTY
04-1	062526	RAMMER SHOE STEEL PLATE	1
04-2	062527	RAMMER SHOE WOODEN PLATE	1
04-3	062528	RAMMER SHOE CLAMP PLATE	1
04-4	061880	FSTN, WASHER W10-DIN-1	8
04-5	061822	FSTN, LOCK NUT M10-DIN-1	8
04-6	061925	FSTN, FHSCS M10x50	8
04-7	061924	FSTN, FHSCS M12x90	2
04-8	061934	FSTN, LOCK NUT M12-DIN-1	4
04-9	061933	FSTN, LW W12-DIN-1	4
04-10	061932	FSTN, WASHER W12-DIN-1	2
04-11	061923	FSTN, FHSCS M12x60	2
04-12	061935	HANDLE	1

**YOUR TOTAL SOURCE FOR CONCRETE EQUIPMENT**

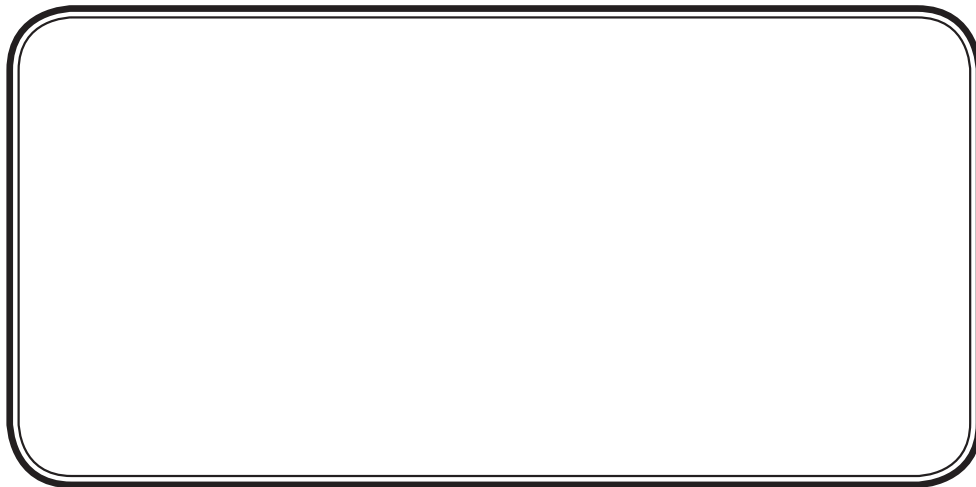

**allen**  
**ENGINEERING**  
CORPORATION

**800-643-0095 or 870-236-7751**  
**FAX: 800-643-0097 or 870-236-3934**

P.O. Box 819 Paragould, Arkansas 72451 USA  
[www.alleneng.com](http://www.alleneng.com)