

Please **Fill in** the desired measurements below:

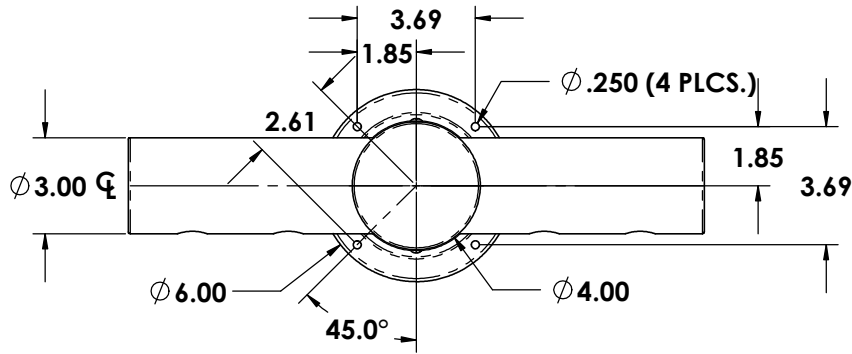

American Coffee
Urn Manufacturing Co., Inc.
 Since 1959
Precision Sheet Metal
 Design ♦ Engineering ♦ Fabrication
www.acumetalfab.com

REV. NO.		REVISIONS	DATE	APPROVED
ZONE	REV.	DESCRIPTION		

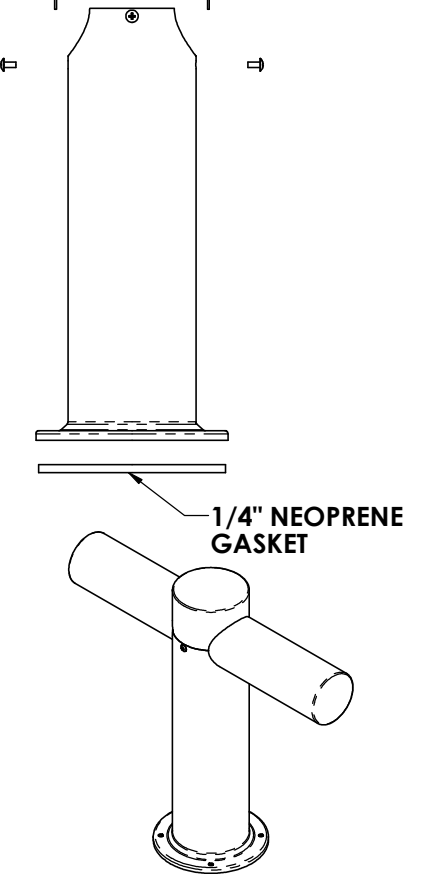
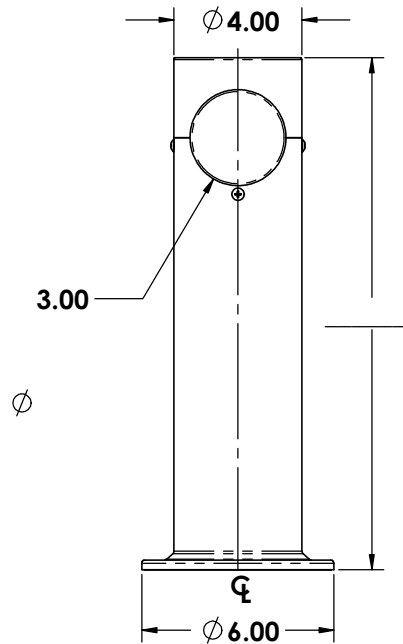
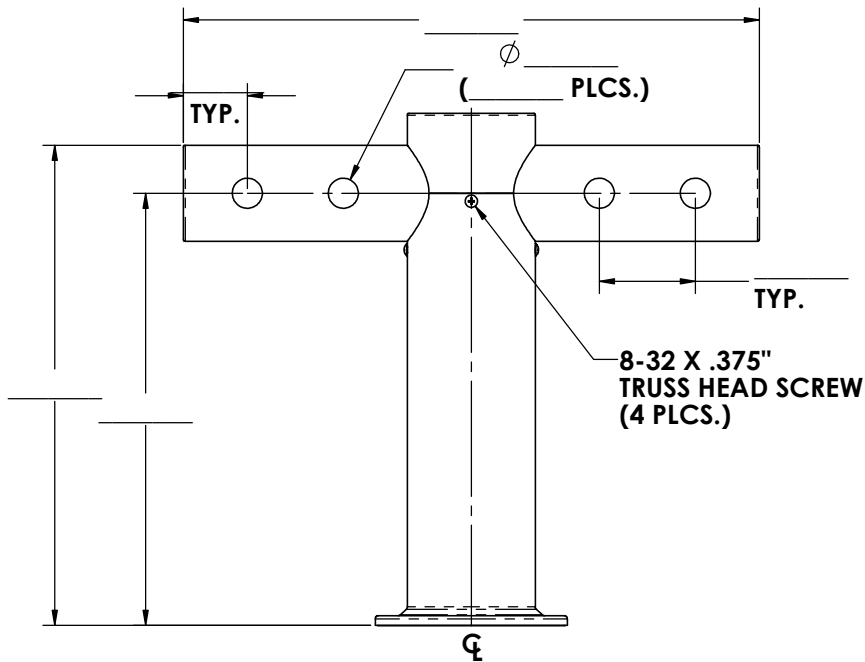
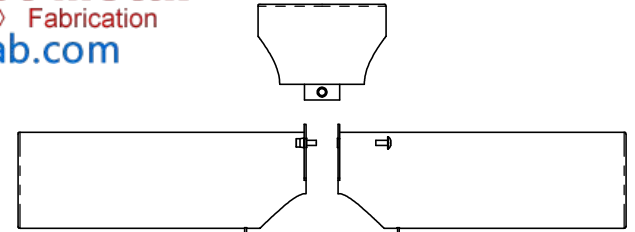

Please **Circle** the desired options Below:

MATERIAL : CROSS TUBE

- 3" X .060 WALL STAINLESS STEEL TUBING
- 4" X .060 WALL STAINLESS STEEL TUBING

PEDESTAL

- 3" X .060 WALL BRASS TUBING
- 4" X .060 WALL BRASS TUBING

FINISHES :

- #4 BRUSHED ON ALL TYPES
- #8 POLISHED ON ALL TYPES

www.acumetalfab.com

Proprietary and Confidential
 The Information contained in this drawing is the sole property of ACU Precision Sheet Metal. Any reproduction in part or as a whole without the written permission of ACU Precision Sheet Metal is Prohibited.
 ACU Precision Sheet Metal is:
 American Coffee Urn Manufacturing Co., Inc.

	NAME	DATE
DRAWN	M. Johs	07/14
MATERIAL	SEE NOTES	
FINISH	SEE NOTES	COMMENTS:

TITLE:
METRO TEE TOWER CUSTOM TEE TOWER
AMERICAN COFFEE URN

DO NOT SCALE DRAWING

4" PEDESTAL AND DRAFT ARM TEMPLATE

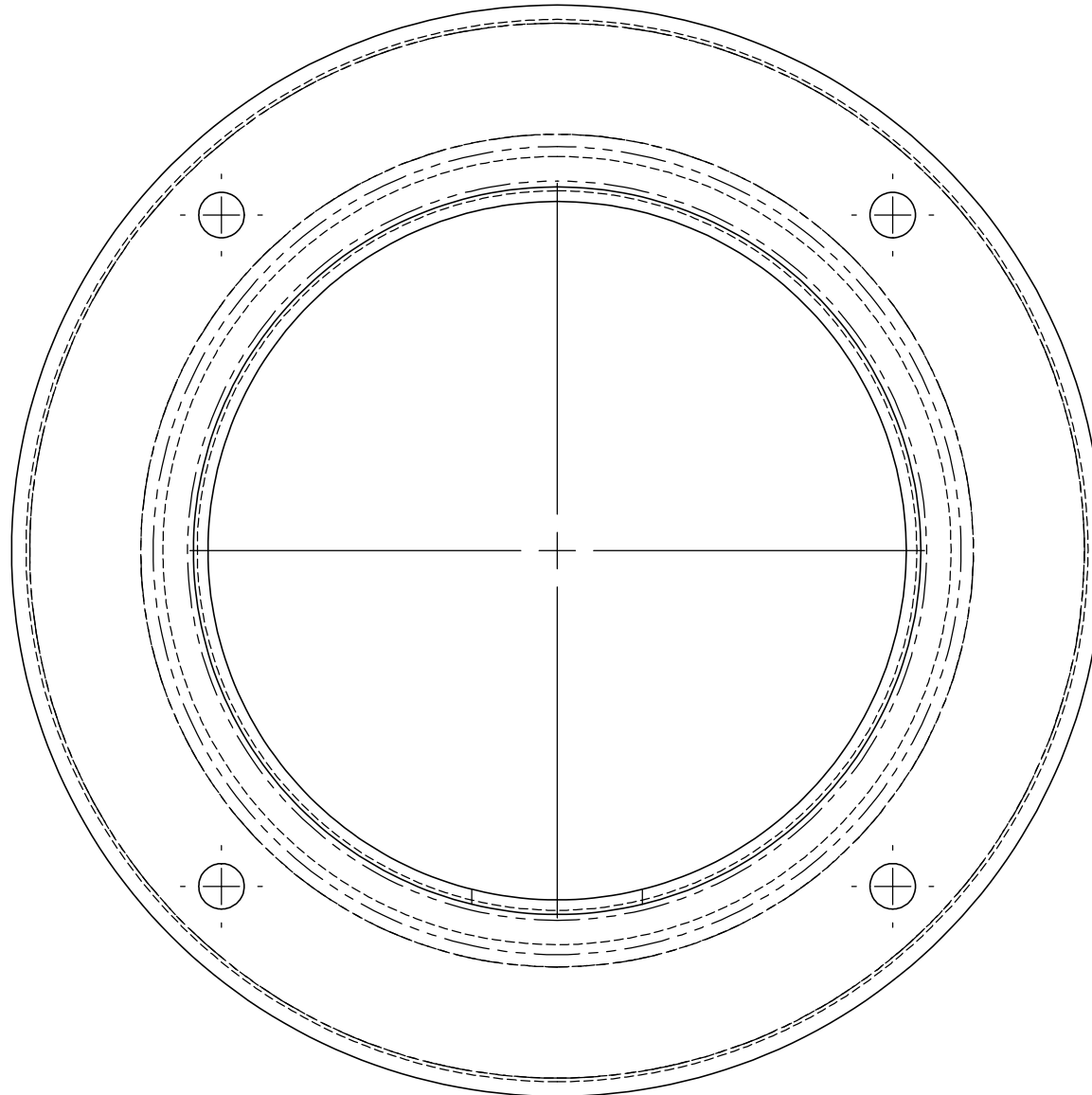

SCALE 1:1

Set printer settings to : Page Scaling = "None"