

PLEASE FILL IN CORRECT MEASUREMENTS WHERE NEEDED!

REV. NO.		REVISIONS	DATE	APPROVED
ZONE	REV.	DESCRIPTION		

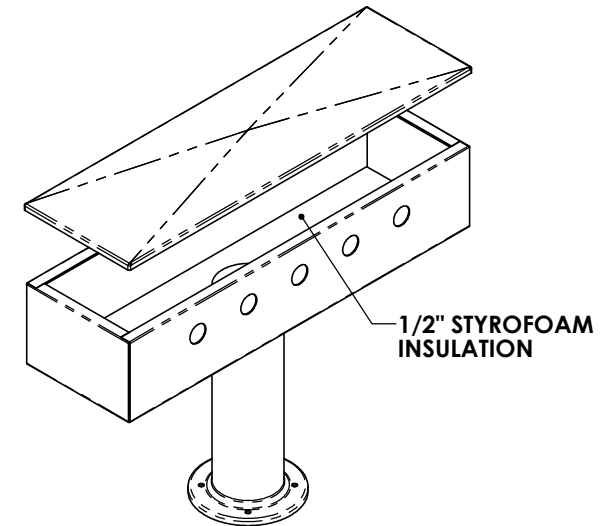
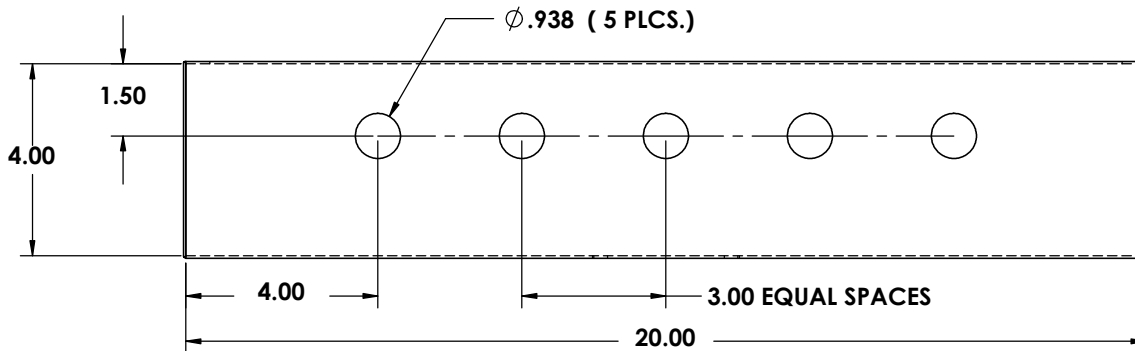
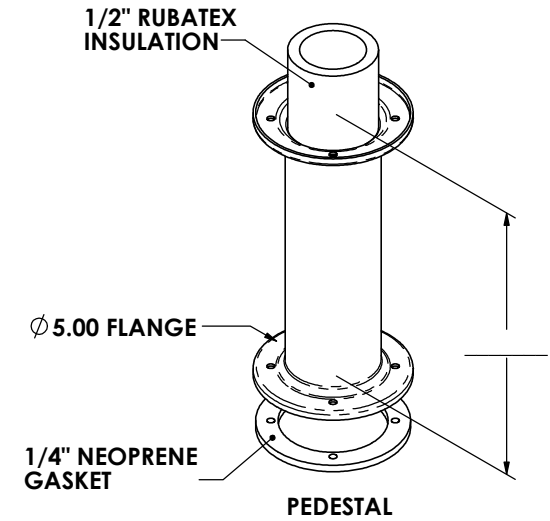
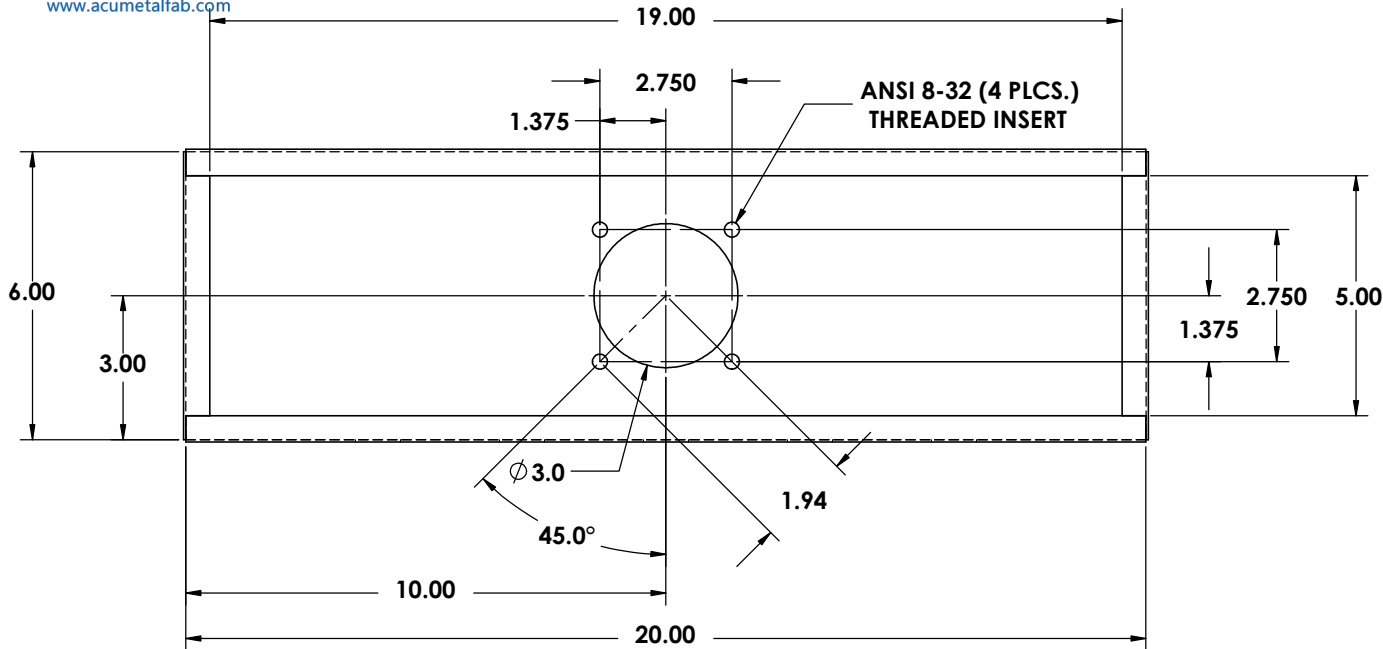

Please Circle the desired options Below:

ALL DIMENSIONS ARE INSIDE DIMENSIONS
 UNLESS OTHERWISE NOTED

MATERIAL :

18 GAUGE STAINLESS STEEL

16 GAUGE STAINLESS STEEL

16 GAUGE BRASS

FINISHES :

#2B SATIN ON ALL TYPES

#4 BRUSHED ON ALL TYPES

#8 POLISHED ON ALL TYPES

www.acumetalfab.com

Proprietary and Confidential
 The Information contained in this drawing is the sole property of ACU Precision Sheet Metal. Any reproduction in part or as a whole without the written permission of ACU Precision Sheet Metal is Prohibited.
 ACU Precision Sheet Metal is:
 American Coffee Urn Manufacturing Co., Inc.

	NAME	DATE	TITLE:
DRAWN	M. Johs	07/14	3" T-TOWER - NO FACEPLATE SGL PED - SGL SERVICE CUSTOM
MATERIAL	SEE NOTES		
FINISH	SEE NOTES	COMMENTS:	AMERICAN COFFEE URN
DO NOT SCALE DRAWING			

3" PEDESTAL AND DRAFT ARM TEMPLATE

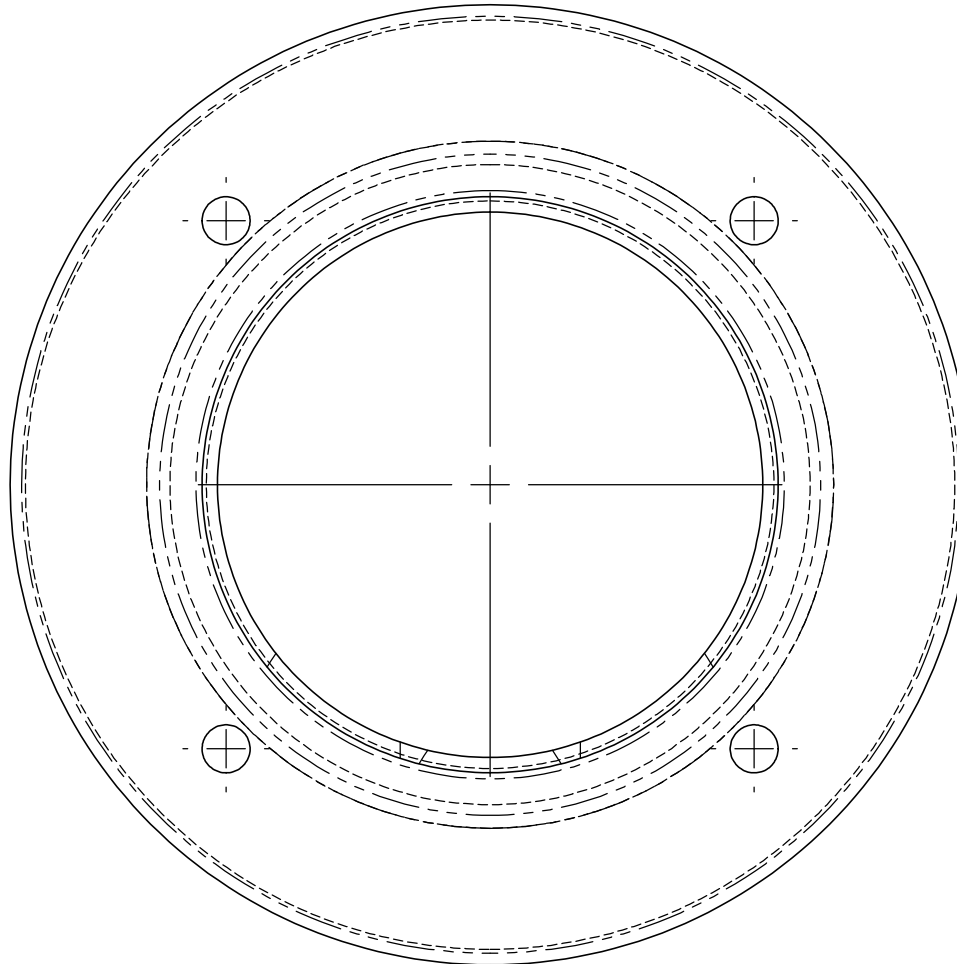

SCALE 1:1

Set printer settings to : Page Scaling = "None"