

CHANGE DIMENSIONS AS NEEDED FOR CUSTOM TRAYS

| REVISIONS | | DATE | APPROVED |
|-----------|------|-------------|----------|
| ZONE | REV. | DESCRIPTION | |
| | | | |
| | | | |

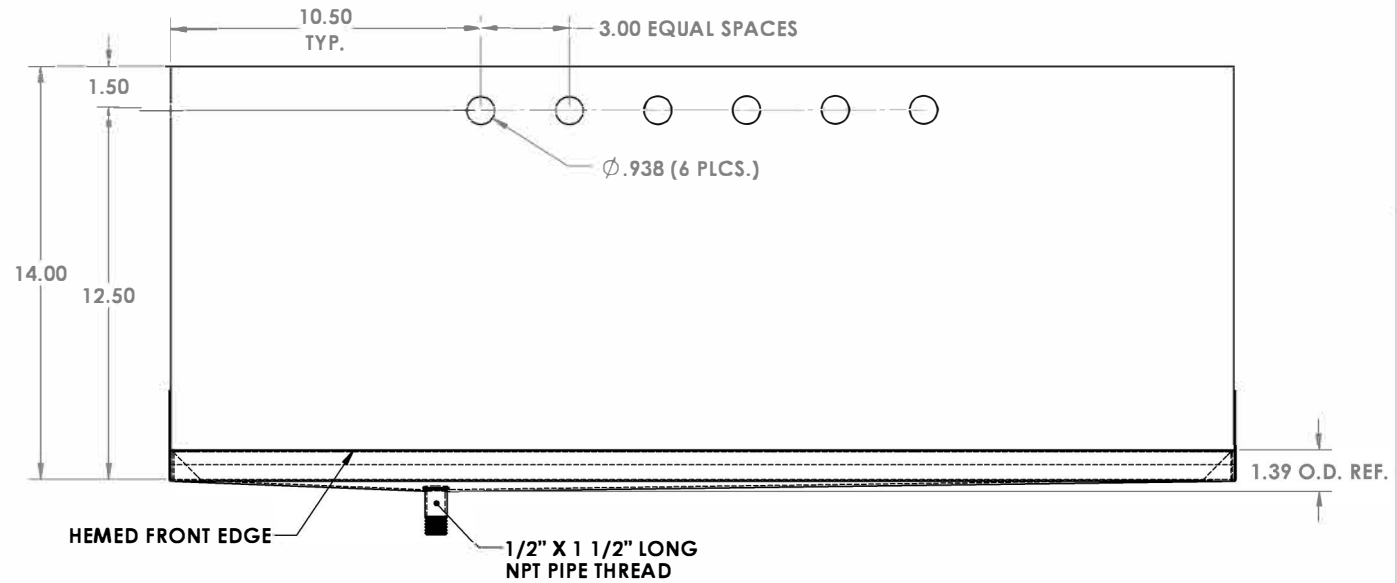
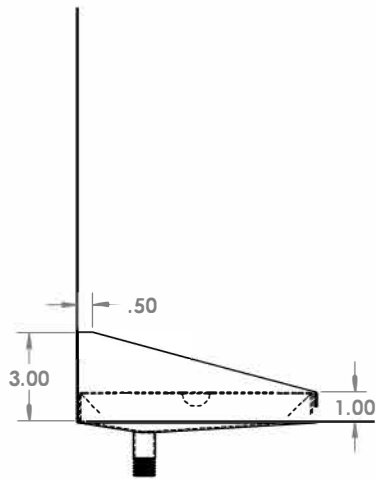
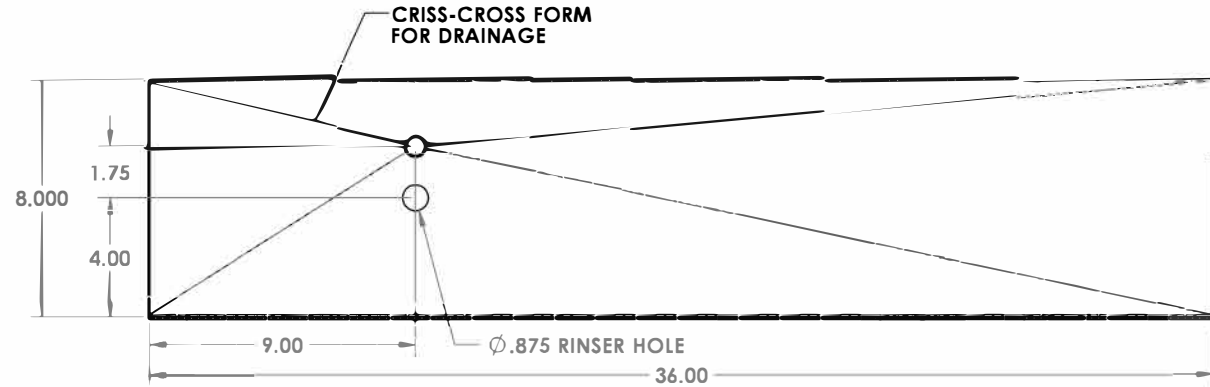
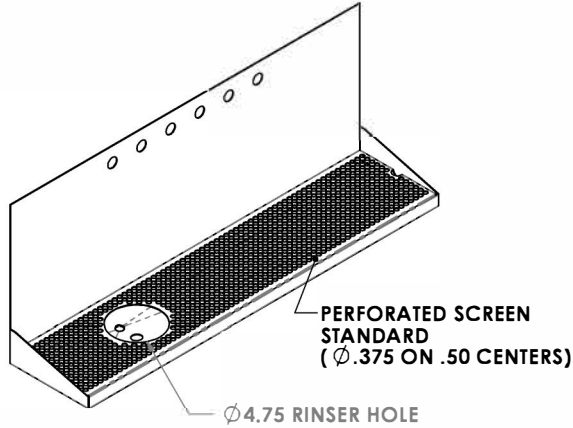

ALL DIMENSIONS ARE INSIDE DIMENSIONS UNLESS OTHERWISE NOTED

MATERIAL : 18 GAUGE STAINLESS STEEL

FINISH : #4 BRUSHED ON ALL TYPES

American Coffee
 Urn Manufacturing Co., Inc. *Since 1959*
 Precision Sheet Metal
 Design ◊ Engineering ◊ Fabrication
 www.acumetalfab.com

ACU#04003606DLSP
 *RINSER HARDWARE NOT INCLUDED

PROPRIETARY AND CONFIDENTIAL
 THE INFORMATION CONTAINED IN THIS DRAWING IS THE SOLE PROPERTY OF ACU PRECISION SHEET METAL. ANY REPRODUCTION IN PART OR AS A WHOLE WITHOUT THE WRITTEN PERMISSION OF ACU PRECISION SHEET METAL IS PROHIBITED.
 ACU PRECISION SHEET METAL IS : AMERICAN COFFEE URN MANUFACTURING CO., INC

| | NAME | DATE |
|----------|-------------|-----------|
| DRAWN | L. WILLIAMS | 04/16 |
| MATERIAL | SEE NOTES | |
| FINISH | SEE NOTES | COMMENTS: |

TITLE: **WM-DR**
6 HOLE 36" WALL MOUNT W/LEFT DRAIN & *RINSER HOLES
AMERICAN COFFEE URN