

REVISIONS		DATE	APPROVED
ZONE	REV.	DESCRIPTION	

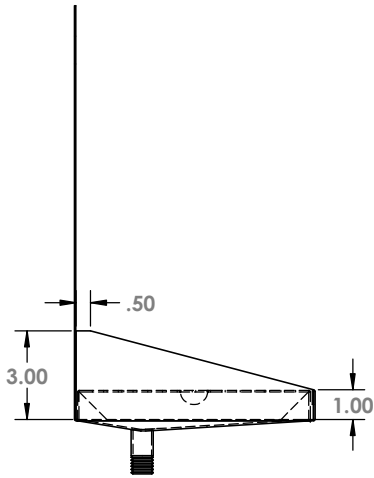
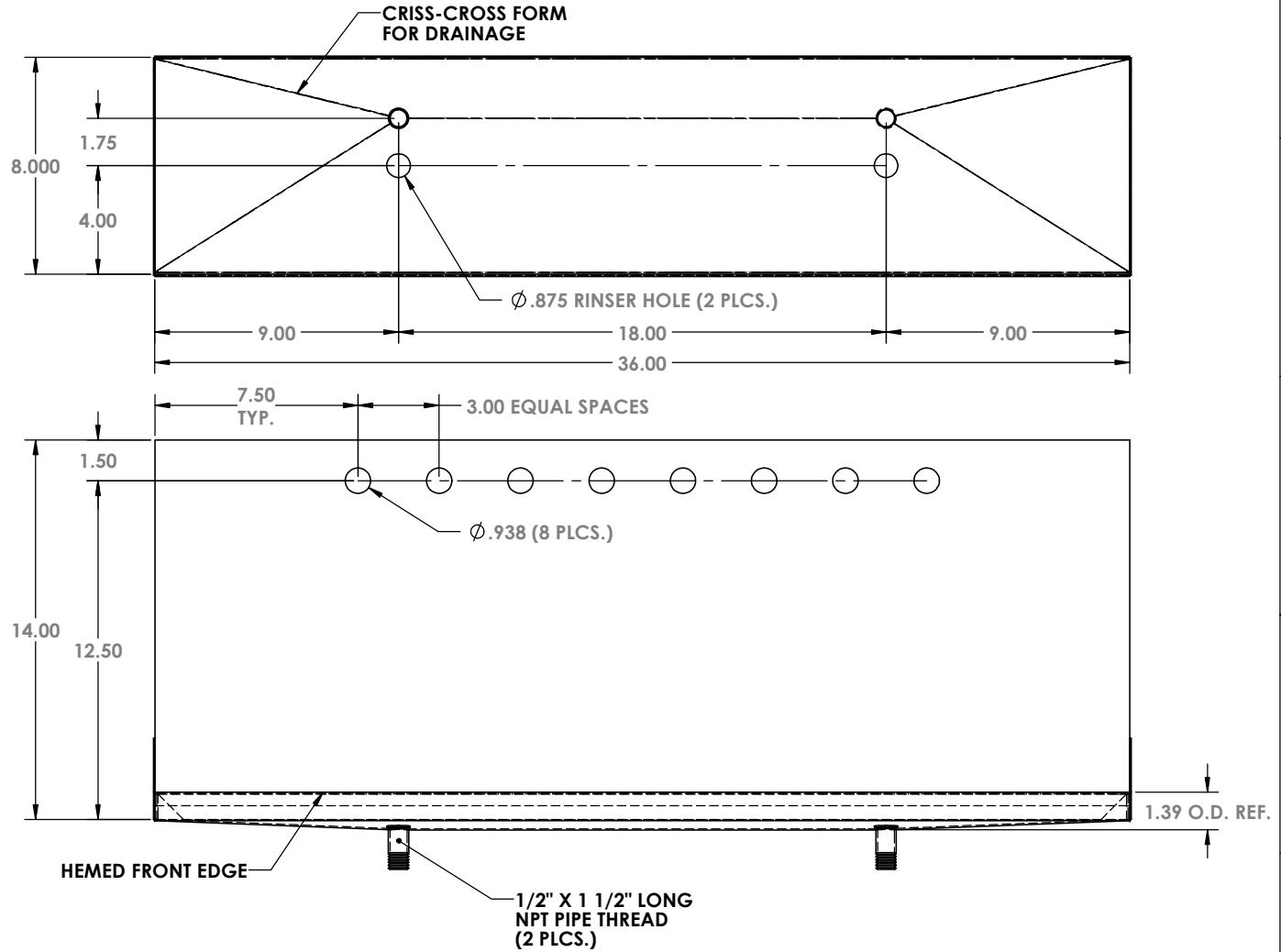
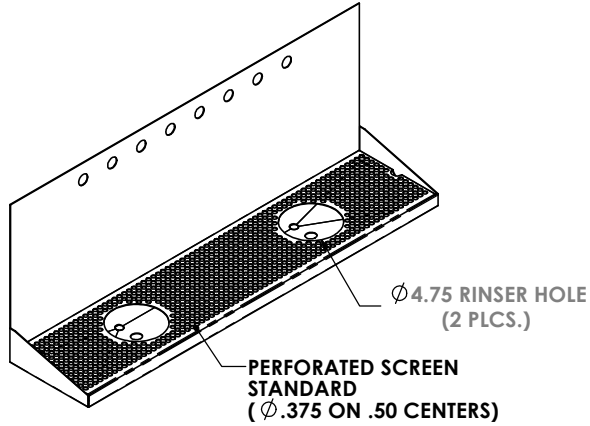

ALL DIMENSIONS ARE INSIDE DIMENSIONS UNLESS OTHERWISE NOTED

MATERIAL : 16 GAUGE BRASS

FINISH : #8 POLISHED ON ALL TYPES

American Coffee
Urn Manufacturing Co., Inc. *Since 1959*

Precision Sheet Metal
Design ♦ Engineering ♦ Fabrication
www.acumetalfab.com

ACU#07403608DDSP
*RINSER HARDWARE NOT INCLUDED

PROPRIETARY AND CONFIDENTIAL
THE INFORMATION CONTAINED IN THIS DRAWING IS THE SOLE PROPERTY OF ACU PRECISION SHEET METAL. ANY REPRODUCTION IN PART OR AS A WHOLE WITHOUT THE WRITTEN PERMISSION OF ACU PRECISION SHEET METAL IS PROHIBITED.
ACU PRECISION SHEET METAL IS : AMERICAN COFFEE URN MANUFACTURING CO., INC

	NAME	DATE
DRAWN	L. WILLIAMS	04/16
MATERIAL	SEE NOTES	
FINISH	SEE NOTES	COMMENTS:
DO NOT SCALE DRAWING		

TITLE:	WM-DDR 8 HOLE 36" WALL MOUNT W/DBL DRAIN & *RINSER HOLES
	AMERICAN COFFEE URN