

CHANGE DIMENSIONS AS NEEDED FOR CUSTOM TRAYS

REVISIONS		DATE	APPROVED
IONE	REV.	DESCRIPTION	

Precision Sheet Metal
 Design ♦ Engineering ♦ Fabrication
 www.acumetalfab.com

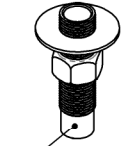

5/8-18 X 3" LONG BRASS DRAIN W/HARDWARE

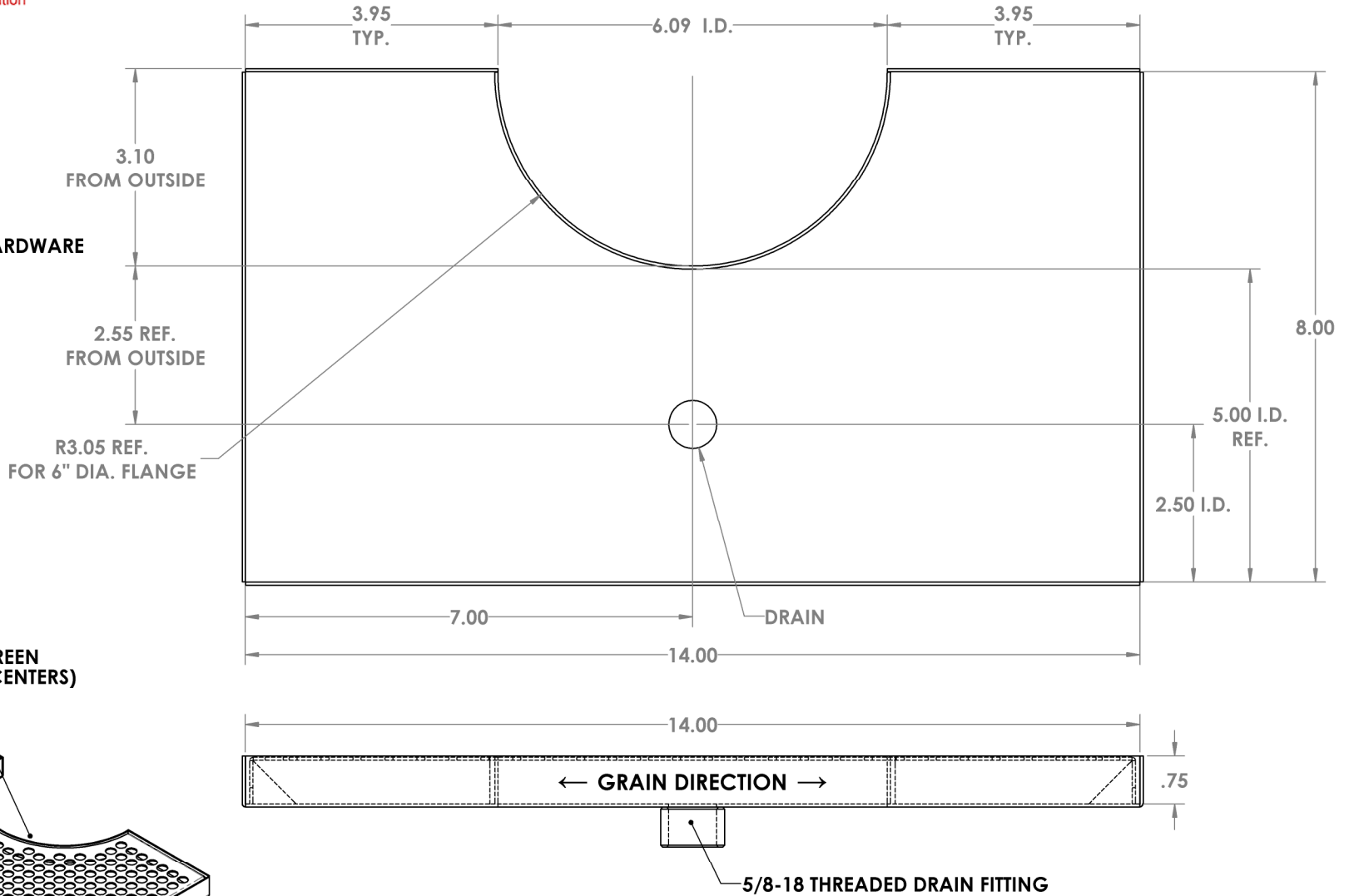

PERFORATED SCREEN (Ø .375 ON .50 CENTERS) STANDARD

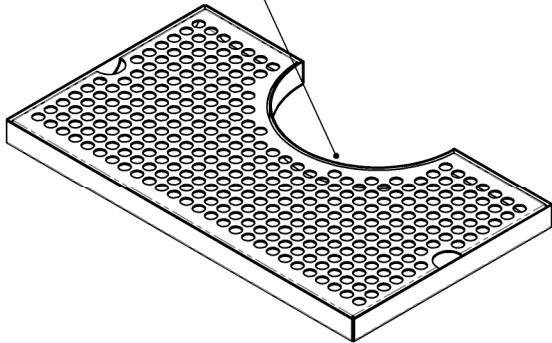

NOTES:

ALL DIMENSIONS ARE INSIDE DIMENSIONS (UNLESS OTHERWISE NOTED)

PART # 0451-14

PROPRIETARY AND CONFIDENTIAL

THE INFORMATION CONTAINED IN THIS DRAWING IS THE SOLE PROPERTY OF ACU PRECISION SHEET METAL. ANY REPRODUCTION IN PART OR AS A WHOLE WITHOUT THE WRITTEN PERMISSION OF ACU PRECISION SHEET METAL IS PROHIBITED.

ACU PRECISION SHEET METAL IS : AMERICAN COFFEE URN MANUFACTURING CO., INC

	NAME	DATE
DRAWN	L. WILLIAMS	12/16
MATERIAL	18 GA. 304 STAINLESS STEEL	
FINISH	#4 BRUSHED	

TITLE: **SM-D**
8" x 14" SURFACE MOUNT W/ DRAIN & CUT OUT FOR 6" FLANGE
AMERICAN COFFEE URN