

CHANGE DIMENSIONS AS NEEDED FOR CUSTOM TRAYS

		REVISIONS	
IONE	REV.	DESCRIPTION	DATE

Precision Sheet Metal
 Design ♦ Engineering ♦ Fabrication
www.acumetalfab.com

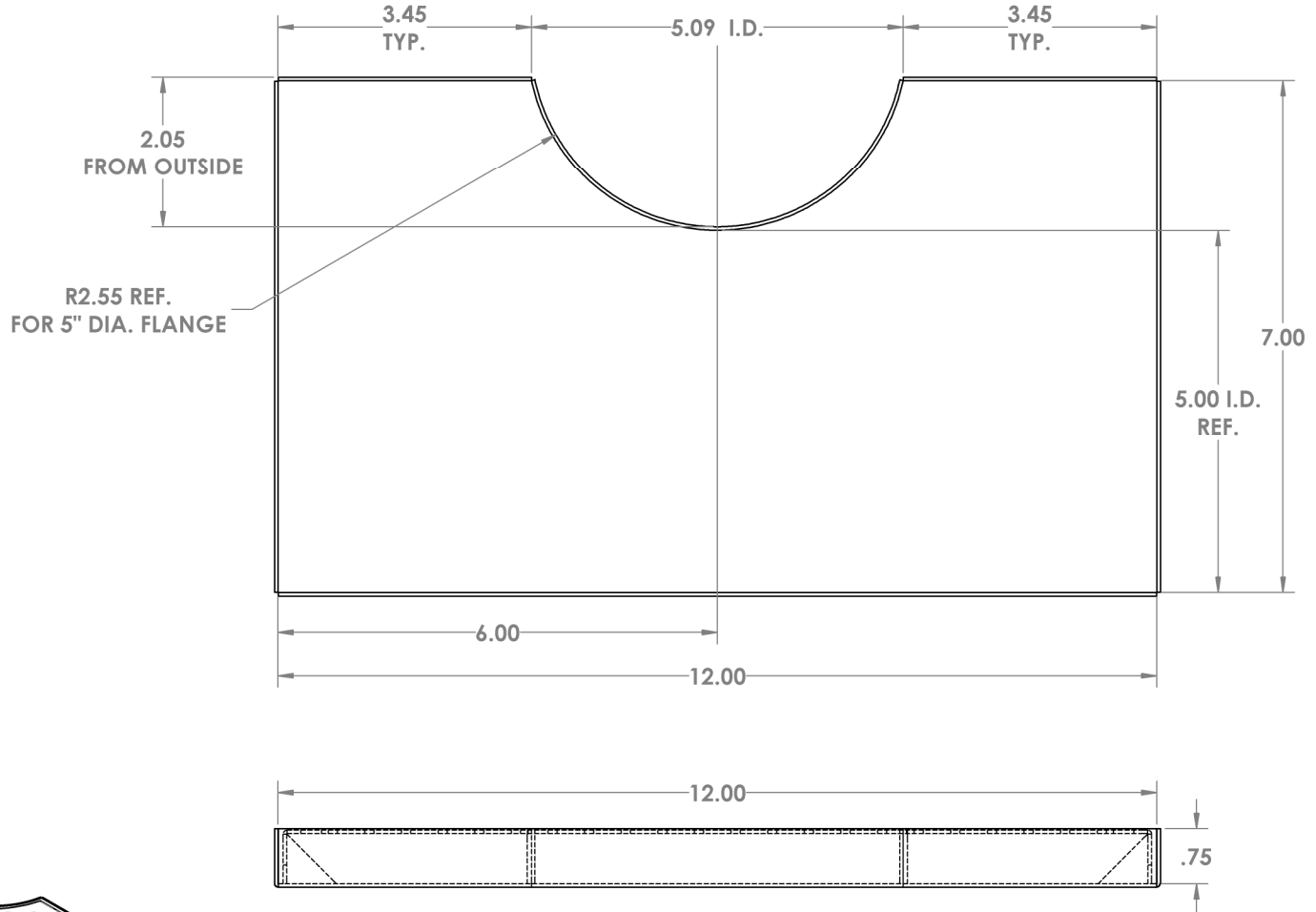

PERFORATED SCREEN
 (Ø.375 ON .50 CENTERS)
 STANDARD

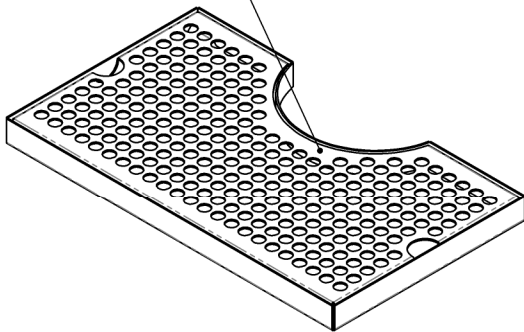

NOTES:

ALL DIMENSIONS ARE INSIDE DIMENSIONS
 (UNLESS OTHERWISE NOTED)

PART # 80880-2-No Drain

PROPRIETARY AND CONFIDENTIAL

THE INFORMATION CONTAINED IN THIS DRAWING IS THE SOLE PROPERTY OF ACU PRECISION SHEET METAL. ANY REPRODUCTION IN PART OR AS A WHOLE WITHOUT THE WRITTEN PERMISSION OF ACU PRECISION SHEET METAL IS PROHIBITED.

ACU PRECISION SHEET METAL IS :
 AMERICAN COFFEE URN MANUFACTURING CO., INC

	NAME	DATE
DRAWN	L. WILLIAMS	12/16
MATERIAL	18 GA. 304 STAINLESS STEEL	
FINISH	#8 POLISHED	

TITLE:
SM 7" x 12" SURFACE MOUNT W/CUT OUT FOR 5" FLANGE
AMERICAN COFFEE URN