

CHANGE DIMENSIONS AS NEEDED FOR CUSTOM TRAYS

		REVISIONS			
DATE	REV.	DESCRIPTION	DATE	APPROVED	

5/8-18 X 3" LONG
 BRASS DRAIN W/HARDWARE

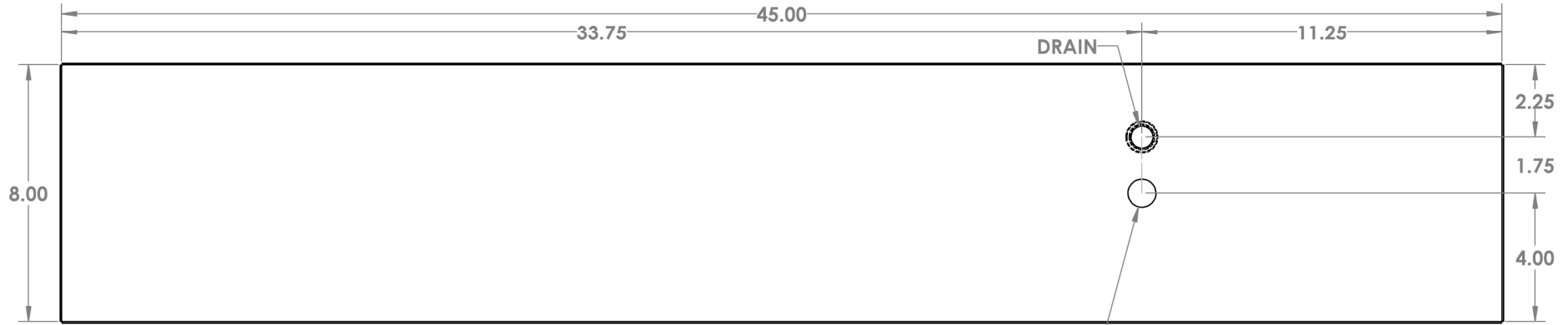

Ø .875
 RINSER HOLE

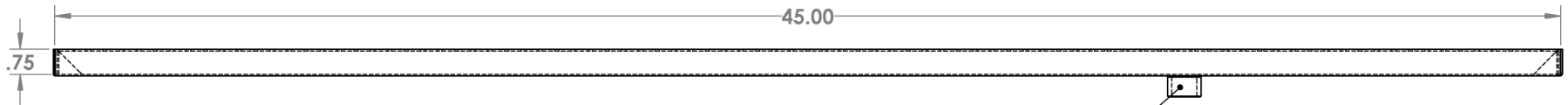

5/8-18 THREADED DRAIN FITTING

Ø 4.75
 RINSER HOLE

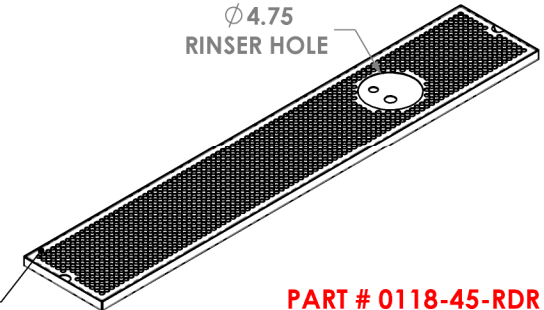

PERFORATED SCREEN
 (Ø .375 ON .50 CENTERS)
 STANDARD

PART # 0118-45-RDR

NOTES:

ALL DIMENSIONS ARE INSIDE DIMENSIONS
 (UNLESS OTHERWISE NOTED)

PROPRIETARY AND CONFIDENTIAL

THE INFORMATION CONTAINED IN THIS DRAWING IS THE SOLE PROPERTY OF ACU PRECISION SHEET METAL. ANY REPRODUCTION IN PART OR AS A WHOLE WITHOUT THE WRITTEN PERMISSION OF ACU PRECISION SHEET METAL IS PROHIBITED.

ACU PRECISION SHEET METAL IS :
 AMERICAN COFFEE URN MANUFACTURING CO., INC

	NAME	DATE
DRAWN	L. WILLIAMS	10/16
MATERIAL	16 GA. BRASS	
FINISH	#8 POLISHED	

TITLE:
SM-RDR SURFACE MOUNT W/RIGHT DRAIN & RINSER HOLE 8" X 45"
AMERICAN COFFEE URN