

**CHANGE DIMENSIONS AS NEEDED FOR CUSTOM TRAYS**

ZONE	REV.	REVISIONS		DATE	APPROVED
		DESCRIPTION			

5/8-18 X 3" LONG BRASS DRAIN W/HARDWARE

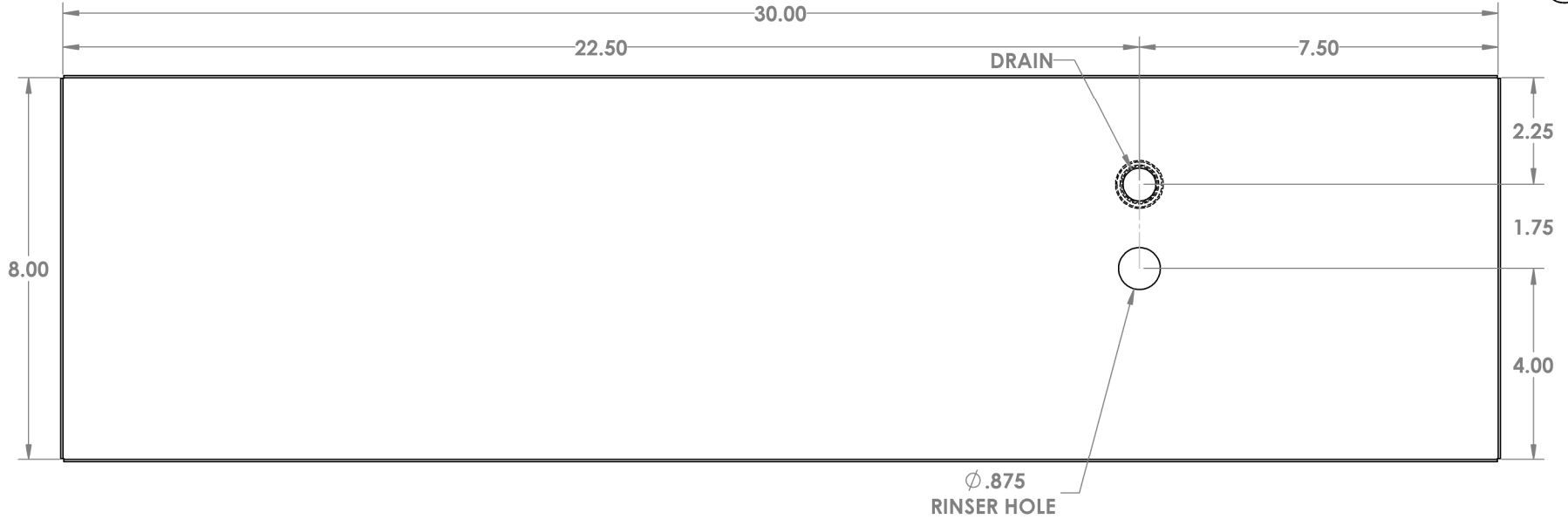
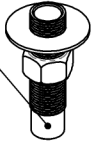

5/8-18 THREADED DRAIN FITTING

Ø 4.75 RINSER HOLE

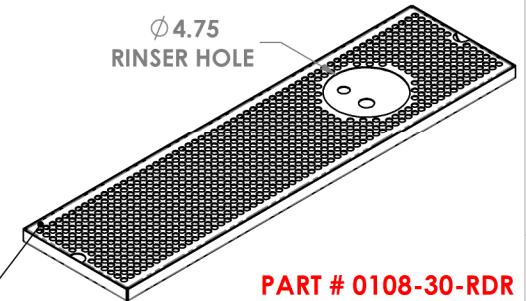

**NOTES:**

ALL DIMENSIONS ARE INSIDE DIMENSIONS (UNLESS OTHERWISE NOTED)

PROPRIETARY AND CONFIDENTIAL  
 THE INFORMATION CONTAINED IN THIS DRAWING IS THE SOLE PROPERTY OF ACU PRECISION SHEET METAL. ANY REPRODUCTION IN PART OR AS A WHOLE WITHOUT THE WRITTEN PERMISSION OF ACU PRECISION SHEET METAL IS PROHIBITED.  
 ACU PRECISION SHEET METAL IS : AMERICAN COFFEE URN MANUFACTURING CO., INC

PERFORATED SCREEN (Ø .375 ON .50 CENTERS) STANDARD

	NAME	DATE
DRAWN	L. WILLIAMS	10/16
MATERIAL	18 GA. 304 STAINLESS STEEL	
FINISH	#4 BRUSHED	

TITLE:
<b>SM-RDR SURFACE MOUNT W/RIGHT DRAIN &amp; RINSER HOLE 8" X 30"</b>
<b>AMERICAN COFFEE URN</b>

**PART # 0108-30-RDR**