

**CHANGE DIMENSIONS AS NEEDED FOR CUSTOM TRAYS**

REV. NO.		REVISIONS	DATE	APPROVED
ZONE	REV.	DESCRIPTION		

**Precision Sheet Metal**  
 Design ♦ Engineering ♦ Fabrication  
 www.acumetalfab.com

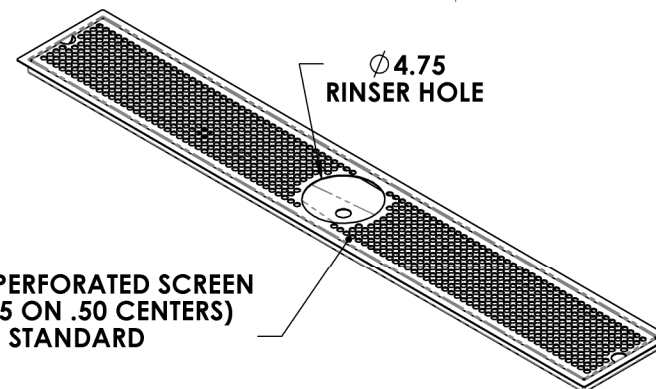
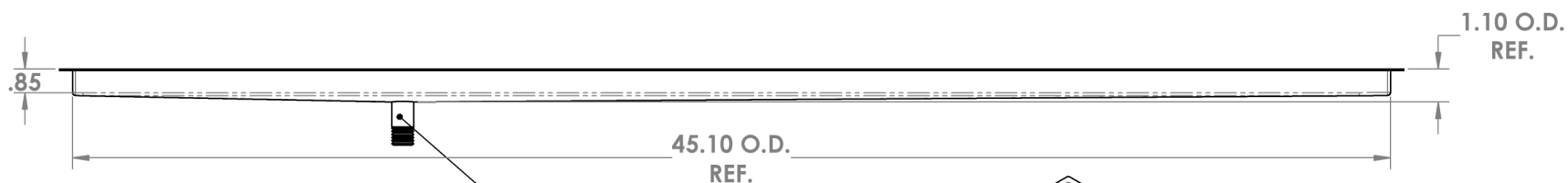
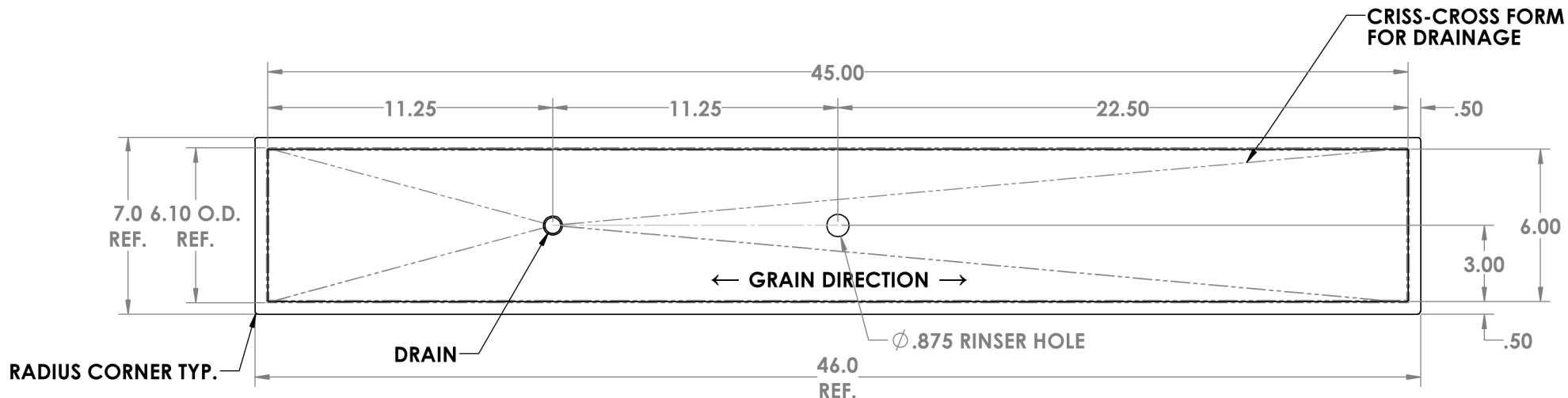

**NOTES:**

ALL DIMENSIONS ARE INSIDE DIMENSIONS (UNLESS OTHERWISE NOTED)

\*RINSER HARDWARE NOT INCLUDED : SOLD SEPARATELY

**PART # 0206-45-9**

PROPRIETARY AND CONFIDENTIAL  
 THE INFORMATION CONTAINED IN THIS DRAWING IS THE SOLE PROPERTY OF ACU PRECISION SHEET METAL. ANY REPRODUCTION IN PART OR AS A WHOLE WITHOUT THE WRITTEN PERMISSION OF ACU PRECISION SHEET METAL IS PROHIBITED.  
 ACU PRECISION SHEET METAL IS : AMERICAN COFFEE URN MANUFACTURING CO., INC

	NAME	DATE
DRAWN	L. WILLIAMS	05/17
MATERIAL	18 GA. 304 STAINLESS STEEL	
FINISH	#4 BRUSHED	

TITLE:
<b>FM-R-OD FLUSH MOUNT W/RINSER HOLE* &amp; OFFSET DRAIN 6" X 45"</b>
<b>AMERICAN COFFEE URN</b>