

CHANGE DIMENSIONS AS NEEDED FOR CUSTOM TRAYS

		REVISIONS			
IONE	REV.	DESCRIPTION	DATE	APPROVED	

Precision Sheet Metal
 Design ♦ Engineering ♦ Fabrication
 www.acumetalfab.com

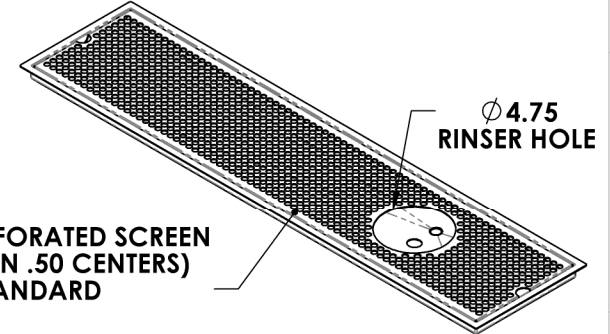
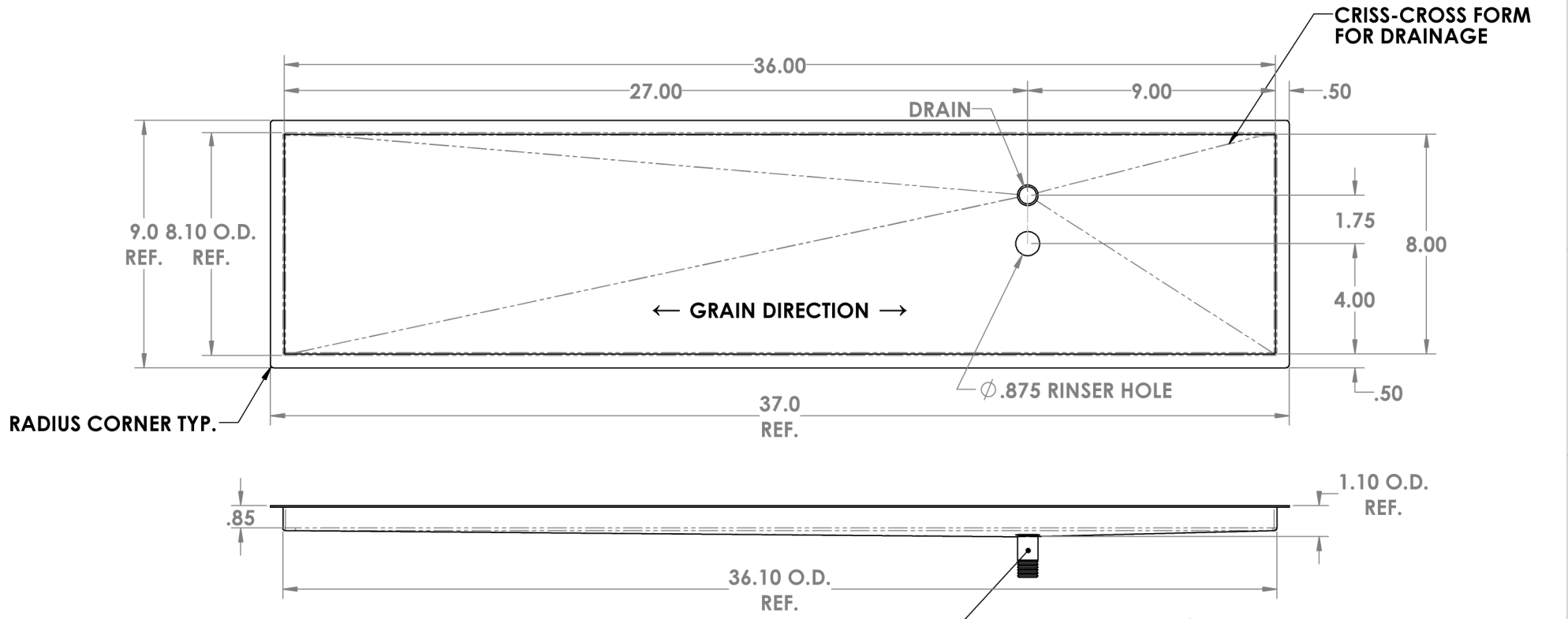

NOTES:

ALL DIMENSIONS ARE INSIDE DIMENSIONS
 (UNLESS OTHERWISE NOTED)

*RINSER HARDWARE NOT INCLUDED : SOLD SEPARATELY

PART # 0208-36-8

PROPRIETARY AND CONFIDENTIAL
 THE INFORMATION CONTAINED IN THIS DRAWING IS THE SOLE PROPERTY OF ACU PRECISION SHEET METAL. ANY REPRODUCTION IN PART OR AS A WHOLE WITHOUT THE WRITTEN PERMISSION OF ACU PRECISION SHEET METAL IS PROHIBITED.
 AMERICAN COFFEE URN MANUFACTURING CO., INC

	NAME	DATE
DRAWN	L. WILLIAMS	05/17
MATERIAL	18 GA. 304 STAINLESS STEEL	
FINISH	#4 BRUSHED	

TITLE:
FM-RDR FLUSH MOUNT W/RIGHT DRAIN & RINSER HOLE* 8" X 36"
AMERICAN COFFEE URN