

CHANGE DIMENSIONS AS NEEDED FOR CUSTOM TRAYS

REV. NO.		REVISIONS	DATE	APPROVED
		DESCRIPTION		

Precision Sheet Metal
 Design ♦ Engineering ♦ Fabrication
 www.acumetalfab.com

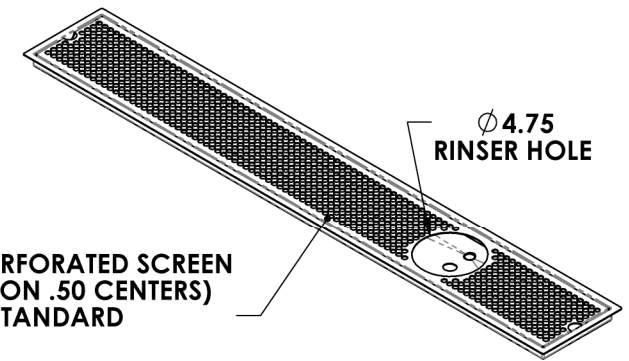
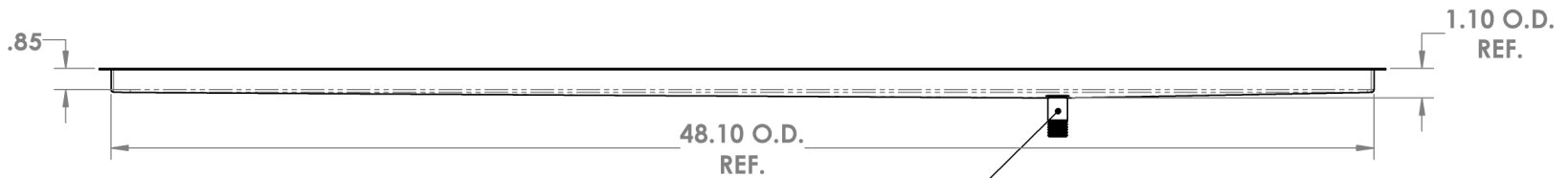
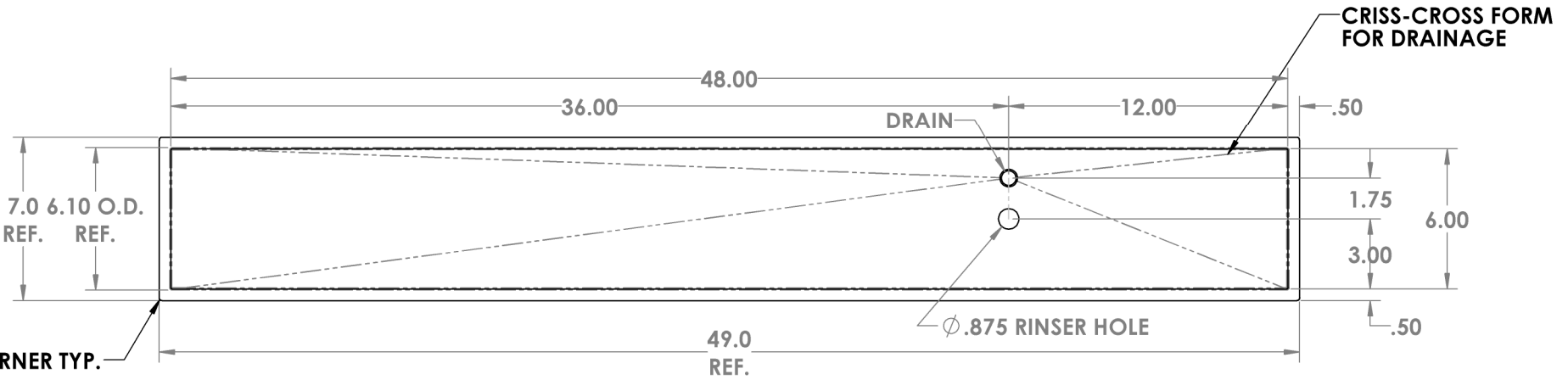

NOTES:

ALL DIMENSIONS ARE INSIDE DIMENSIONS (UNLESS OTHERWISE NOTED)

*RINSER HARDWARE NOT INCLUDED : SOLD SEPARATELY

PART # 0706-48-8

PROPRIETARY AND CONFIDENTIAL
 THE INFORMATION CONTAINED IN THIS DRAWING IS THE SOLE PROPERTY OF ACU PRECISION SHEET METAL. ANY REPRODUCTION IN PART OR AS A WHOLE WITHOUT THE WRITTEN PERMISSION OF ACU PRECISION SHEET METAL IS PROHIBITED.
 ACU PRECISION SHEET METAL IS : AMERICAN COFFEE URN MANUFACTURING CO., INC

	NAME	DATE
DRAWN	L. WILLIAMS	05/17
MATERIAL	16 GA. BRASS	
FINISH	#8 POLISHED	

TITLE:
FM-RDR FLUSH MOUNT W/RIGHT DRAIN & RINSER HOLE* 6" X 48"
AMERICAN COFFEE URN