

CHANGE DIMENSIONS AS NEEDED FOR CUSTOM TRAYS

REV. NO.		REVISIONS	DATE	APPROVED

Precision Sheet Metal
 Design ♦ Engineering ♦ Fabrication
 www.acumetalfab.com

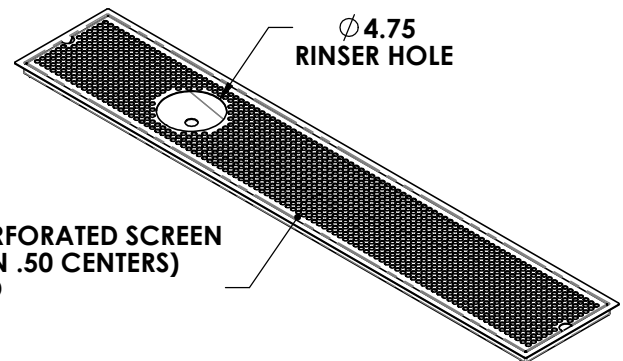
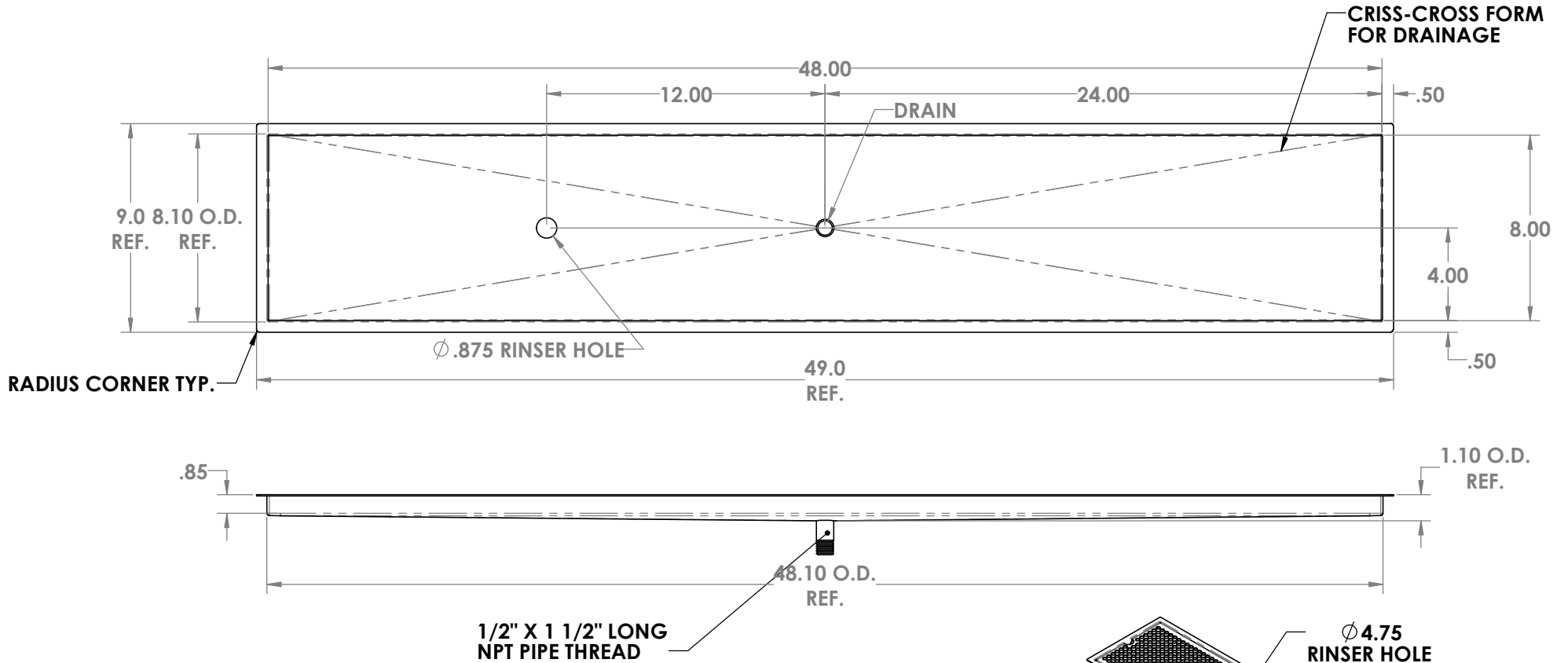

NOTES:

ALL DIMENSIONS ARE INSIDE DIMENSIONS (UNLESS OTHERWISE NOTED)

*RINSER HARDWARE NOT INCLUDED : SOLD SEPARATELY

PART # 0708-48-4

PROPRIETARY AND CONFIDENTIAL
 THE INFORMATION CONTAINED IN THIS DRAWING IS THE SOLE PROPERTY OF ACU PRECISION SHEET METAL. ANY REPRODUCTION IN PART OR AS A WHOLE WITHOUT THE WRITTEN PERMISSION OF ACU PRECISION SHEET METAL IS PROHIBITED.
 AMERICAN COFFEE URN MANUFACTURING CO., INC

	NAME	DATE
DRAWN	L. WILLIAMS	05/17
MATERIAL	16 GA. BRASS	
FINISH	#8 POLISHED	

TITLE:
FM-D-OR FLUSH MOUNT W/DRAIN & OFFSET RINSER HOLE* 8" X 48"
AMERICAN COFFEE URN