

CHANGE DIMENSIONS AS NEEDED FOR CUSTOM TRAYS

| | | REVISIONS | | | |
|------|------|-------------|------|----------|--|
| ZONE | REV. | DESCRIPTION | DATE | APPROVED | |
| | | | | | |
| | | | | | |

Precision Sheet Metal
 Design ♦ Engineering ♦ Fabrication
 www.acumetalfab.com

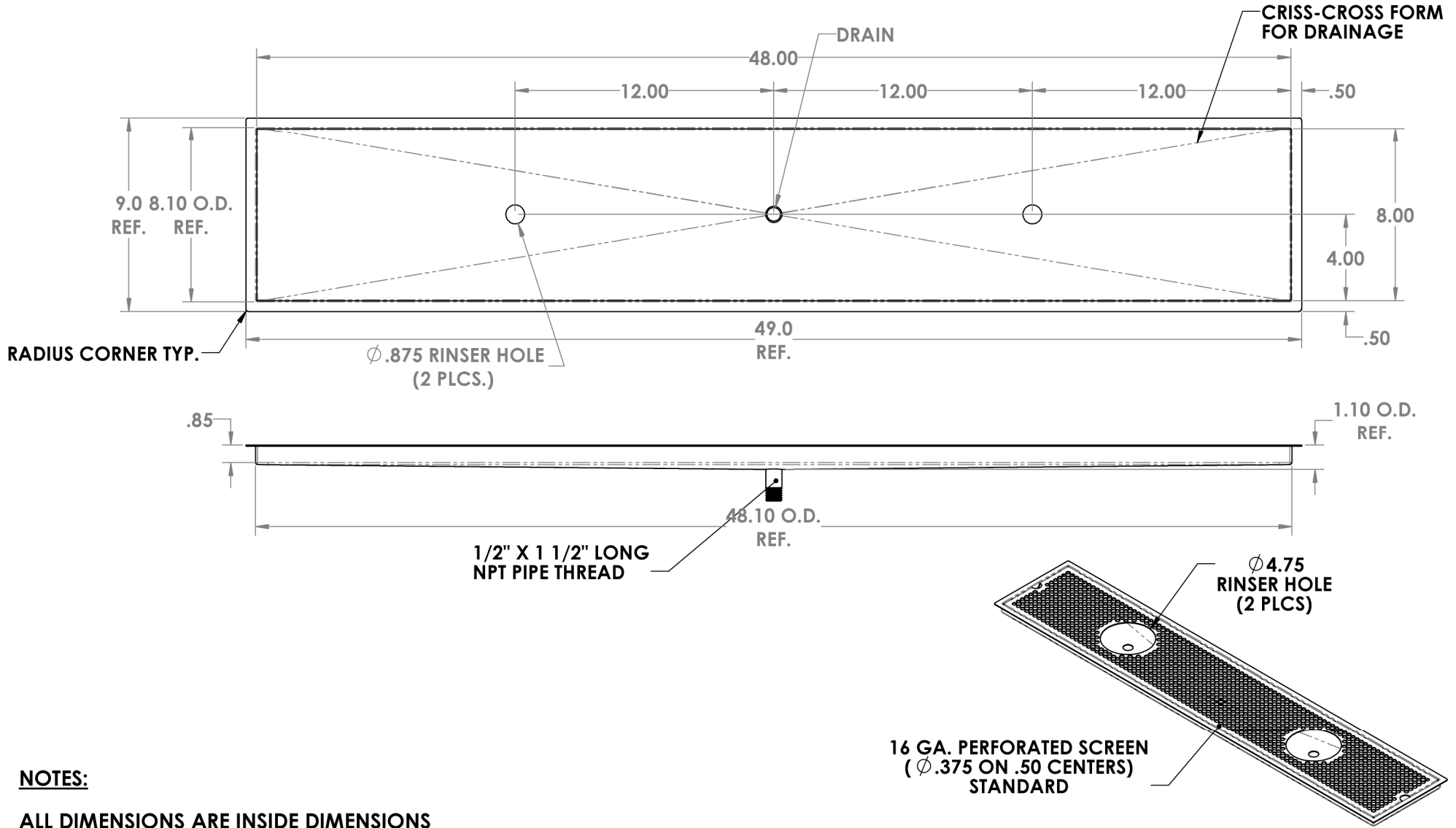

NOTES:

ALL DIMENSIONS ARE INSIDE DIMENSIONS (UNLESS OTHERWISE NOTED)

*RINSER HARDWARE NOT INCLUDED : SOLD SEPARATELY

PROPRIETARY AND CONFIDENTIAL
 THE INFORMATION CONTAINED IN THIS DRAWING IS THE SOLE PROPERTY OF ACU PRECISION SHEET METAL. ANY REPRODUCTION IN PART OR AS A WHOLE WITHOUT THE WRITTEN PERMISSION OF ACU PRECISION SHEET METAL IS PROHIBITED.
 AMERICAN COFFEE URN MANUFACTURING CO., INC

| | NAME | DATE |
|----------|--------------|-------|
| DRAWN | L. WILLIAMS | 05/17 |
| MATERIAL | 16 GA. BRASS | |
| FINISH | #8 POLISHED | |

| TITLE: |
|---|
| FM-D-DR FLUSH MOUNT W/DRAIN & DOUBLE RINSER HOLES* 8" X 48" |
| AMERICAN COFFEE URN |

PART # 0708-48-5