

CHANGE DIMENSIONS AS NEEDED FOR CUSTOM TRAYS

REV. NO.		REVISIONS	DATE	APPROVED
		DESCRIPTION		

Precision Sheet Metal
 Design ♦ Engineering ♦ Fabrication
 www.acumetalfab.com

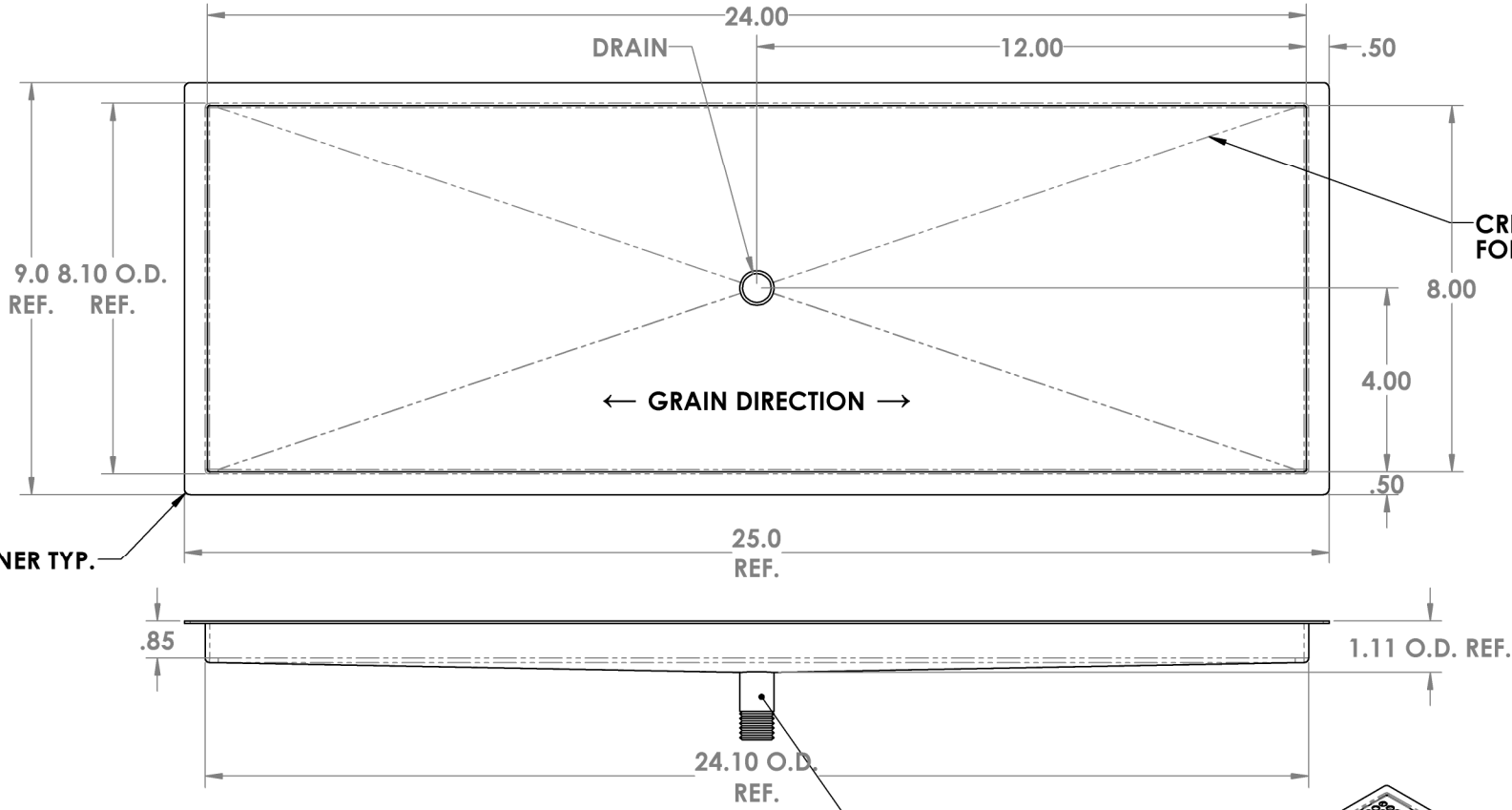

CRISS-CROSS FORM FOR DRAINAGE

← GRAIN DIRECTION →

RADIUS CORNER TYP.

1/2" X 1 1/2" LONG NPT PIPE THREAD

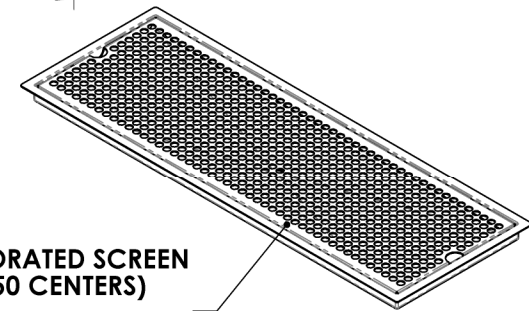

18 GA. PERFORATED SCREEN (Ø .375 ON .50 CENTERS) STANDARD

PART # 0208-24-0

NOTES:
 ALL DIMENSIONS ARE INSIDE DIMENSIONS (UNLESS OTHERWISE NOTED)

PROPRIETARY AND CONFIDENTIAL
 THE INFORMATION CONTAINED IN THIS DRAWING IS THE SOLE PROPERTY OF ACU PRECISION SHEET METAL. ANY REPRODUCTION IN PART OR AS A WHOLE WITHOUT THE WRITTEN PERMISSION OF ACU PRECISION SHEET METAL IS PROHIBITED.
 ACU PRECISION SHEET METAL IS : AMERICAN COFFEE URN MANUFACTURING CO., INC

	NAME	DATE	TITLE:
DRAWN	L. WILLIAMS	05/17	FM-D FLUSH MOUNT W/DRAIN 8" X 24" AMERICAN COFFEE URN
MATERIAL	18 GA. 304 STAINLESS STEEL		
FINISH	#4 BRUSHED		