

CHANGE DIMENSIONS AS NEEDED FOR CUSTOM TRAYS

DATE	REV.	REVISIONS		DATE	APPROVED
		DESCRIPTION			

Precision Sheet Metal
 Design ♦ Engineering ♦ Fabrication
 www.acumetalfab.com

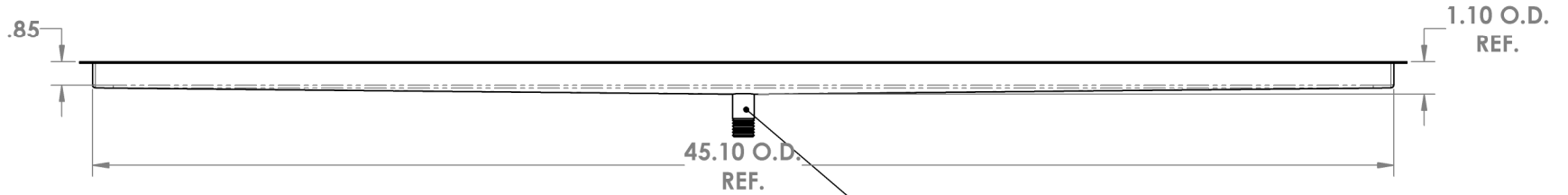
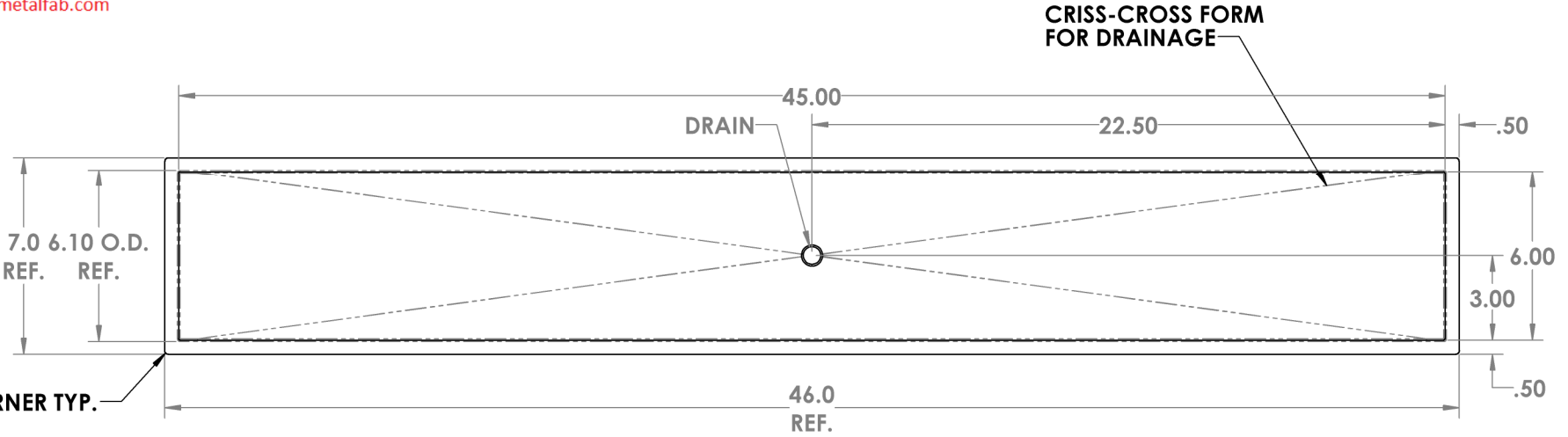

1/2" X 1 1/2" LONG
 NPT PIPE THREAD

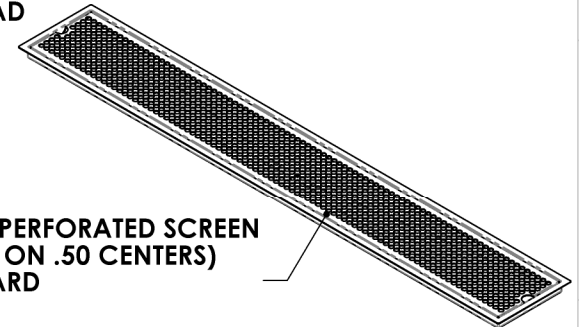

PART # 0706-45-0

NOTES:

**ALL DIMENSIONS ARE INSIDE DIMENSIONS
 (UNLESS OTHERWISE NOTED)**

PROPRIETARY AND CONFIDENTIAL

THE INFORMATION CONTAINED IN THIS DRAWING IS THE SOLE PROPERTY OF ACU PRECISION SHEET METAL. ANY REPRODUCTION IN PART OR AS A WHOLE WITHOUT THE WRITTEN PERMISSION OF ACU PRECISION SHEET METAL IS PROHIBITED.

ACU PRECISION SHEET METAL IS :
 AMERICAN COFFEE URN MANUFACTURING CO., INC

	NAME	DATE
DRAWN	L. WILLIAMS	05/17
MATERIAL	16 GA. BRASS	
FINISH	#8 POLISHED	

TITLE:
FM-D FLUSH MOUNT W/DRAIN 6" X 45"
AMERICAN COFFEE URN