

CHANGE DIMENSIONS AS NEEDED FOR CUSTOM TRAYS

ZONE	REV.	REVISIONS		DATE	APPROVED
		DESCRIPTION			

Precision Sheet Metal
 Design ♦ Engineering ♦ Fabrication
 www.acumetalfab.com

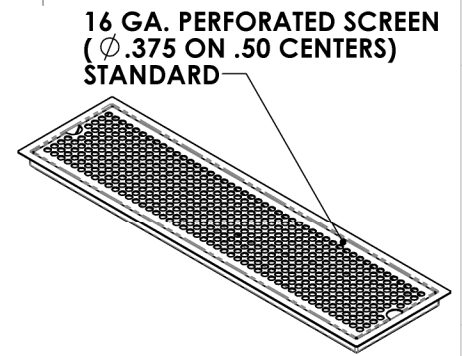
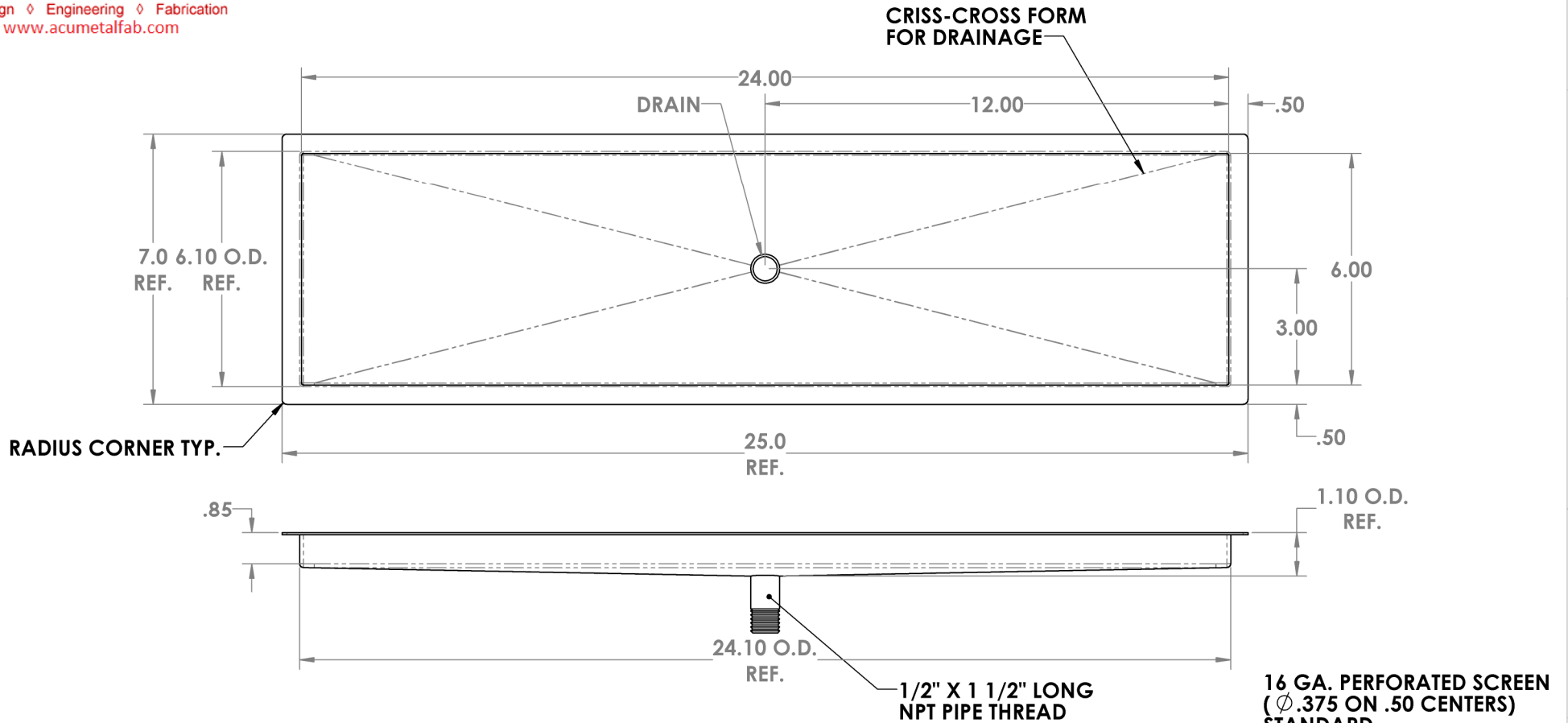

PART # 0706-24-0

NOTES:
 ALL DIMENSIONS ARE INSIDE DIMENSIONS (UNLESS OTHERWISE NOTED)

PROPRIETARY AND CONFIDENTIAL THE INFORMATION CONTAINED IN THIS DRAWING IS THE SOLE PROPERTY OF ACU PRECISION SHEET METAL. ANY REPRODUCTION IN PART OR AS A WHOLE WITHOUT THE WRITTEN PERMISSION OF ACU PRECISION SHEET METAL IS PROHIBITED. AMERICAN COFFEE URN MANUFACTURING CO., INC.	NAME	DATE	TITLE:	
	DRAWN	L. WILLIAMS		05/17
	MATERIAL	16 GA. BRASS		FM-D FLUSH MOUNT W/DRAIN 6" X 24"
	FINISH	#8 POLISHED		
DO NOT SCALE DRAWING			AMERICAN COFFEE URN	