

CHANGE DIMENSIONS AS NEEDED FOR CUSTOM TRAYS

I	O	N	E	REVISIONS		DATE	APPROVED
				DESCRIPTION			

Precision Sheet Metal
 Design ♦ Engineering ♦ Fabrication
 www.acumetalfab.com

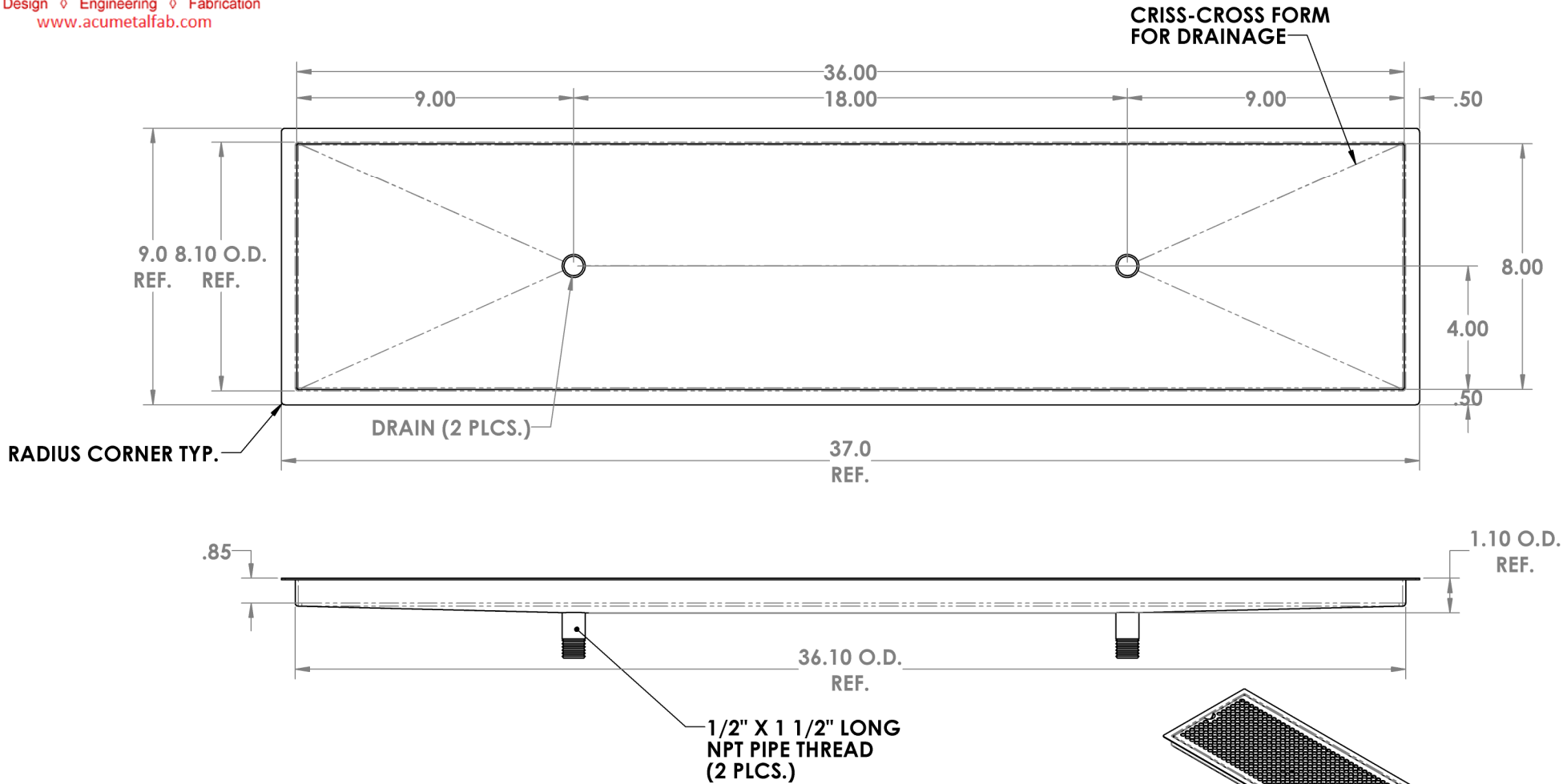

NOTES:
 ALL DIMENSIONS ARE INSIDE DIMENSIONS
 (UNLESS OTHERWISE NOTED)

**18 GA. PERFORATED SCREEN
 (Ø .375 ON .50 CENTERS)
 STANDARD**

PART # 80708-36-2

PROPRIETARY AND CONFIDENTIAL THE INFORMATION CONTAINED IN THIS DRAWING IS THE SOLE PROPERTY OF ACU PRECISION SHEET METAL. ANY REPRODUCTION IN PART OR AS A WHOLE WITHOUT THE WRITTEN PERMISSION OF ACU PRECISION SHEET METAL IS PROHIBITED. AMERICAN COFFEE URN MANUFACTURING CO., INC		NAME L. WILLIAMS	DATE 05/17	TITLE: FM-DD FLUSH MOUNT W/DBL. DRAIN 8" X 36"
DRAWN	MATERIAL 18 GA. 304 STAINLESS STEEL		FINISH #8 POLISHED	AMERICAN COFFEE URN