

CHANGE DIMENSIONS AS NEEDED FOR CUSTOM TRAYS

DATE	REV.	REVISIONS	
		DESCRIPTION	DATE

Precision Sheet Metal
 Design ♦ Engineering ♦ Fabrication
 www.acumetalfab.com

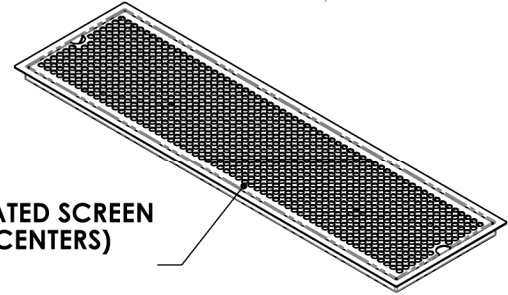
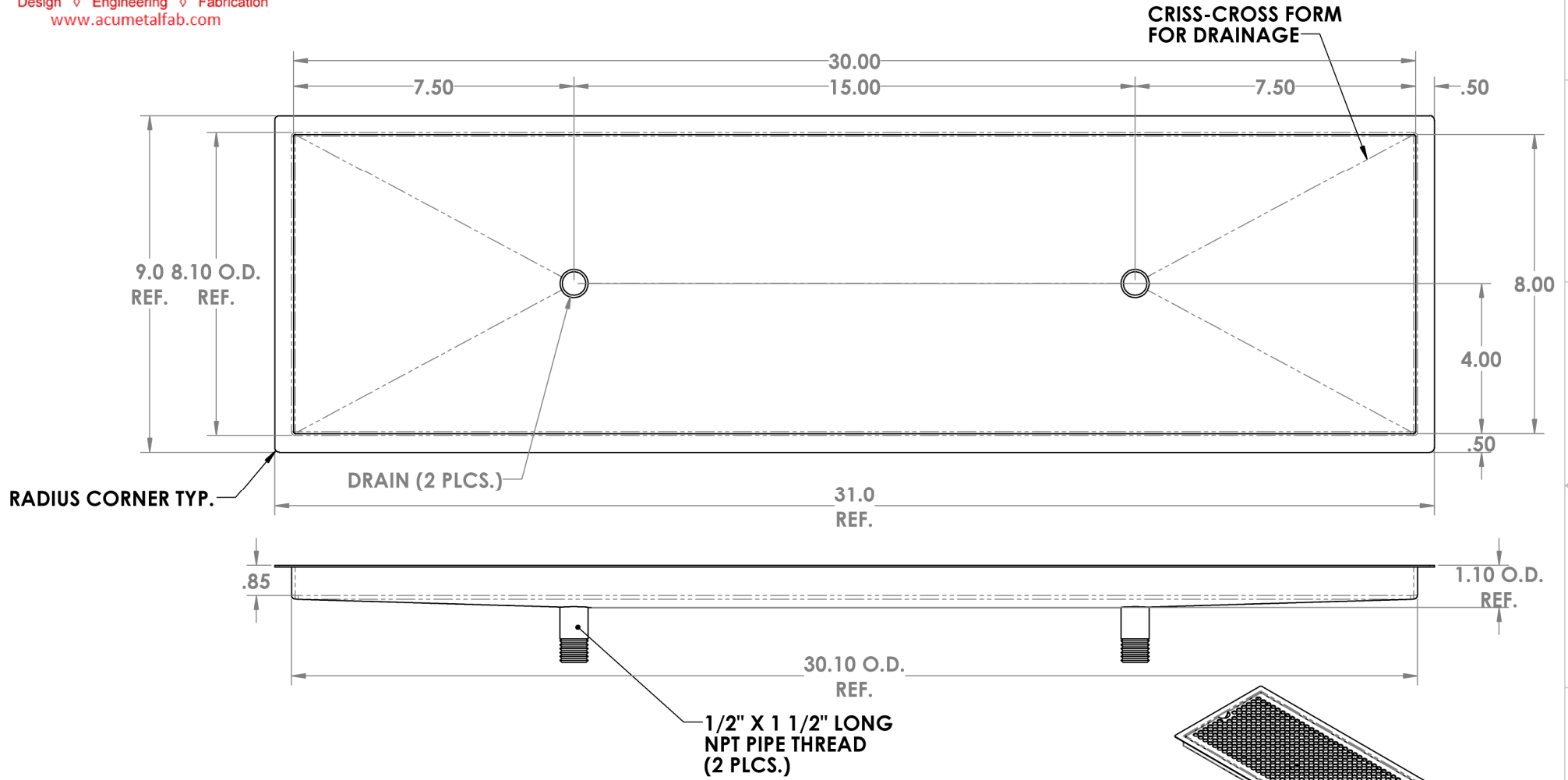

**16 GA. PERFORATED SCREEN
 (Ø .375 ON .50 CENTERS)
 STANDARD**

PART # 0708-30-2

NOTES:
 ALL DIMENSIONS ARE INSIDE DIMENSIONS
 (UNLESS OTHERWISE NOTED)

PROPRIETARY AND CONFIDENTIAL THE INFORMATION CONTAINED IN THIS DRAWING IS THE SOLE PROPERTY OF ACU PRECISION SHEET METAL. ANY REPRODUCTION IN PART OR AS A WHOLE WITHOUT THE WRITTEN PERMISSION OF ACU PRECISION SHEET METAL IS PROHIBITED. AMERICAN COFFEE URN MANUFACTURING CO., INC.		NAME L. WILLIAMS	DATE 05/17	TITLE: FM-DD FLUSH MOUNT W/DBL. DRAIN 8" X 30"
DRAWN	MATERIAL 16 GA. BRASS		FINISH #8 POLISHED	
AMERICAN COFFEE URN				