

CHANGE DIMENSIONS AS NEEDED FOR CUSTOM TRAYS

| | | REVISIONS | | | |
|------|------|-------------|------|----------|--|
| IONE | REV. | DESCRIPTION | DATE | APPROVED | |
| | | | | | |
| | | | | | |

Precision Sheet Metal
 Design ♦ Engineering ♦ Fabrication
 www.acumetalfab.com

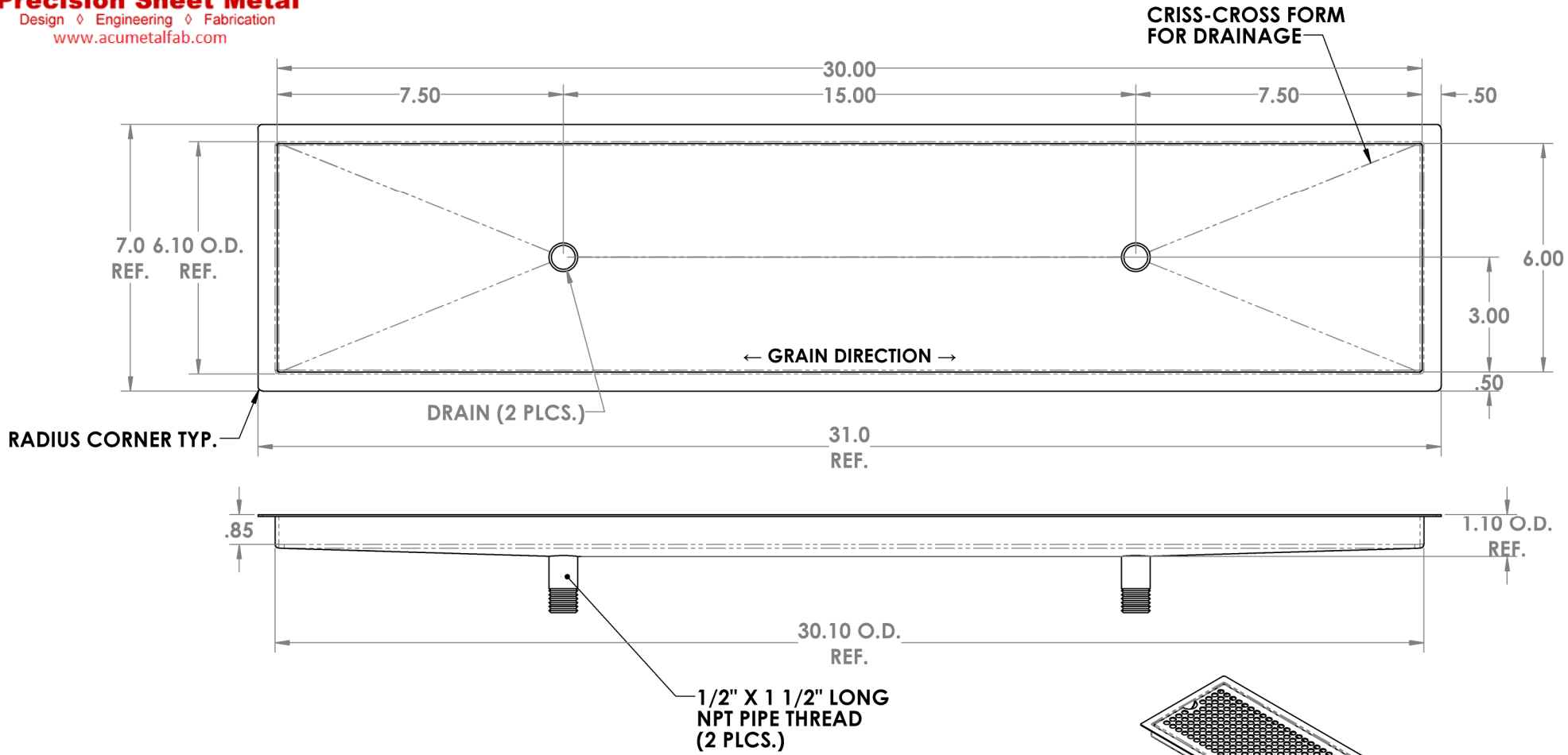

RADIUS CORNER TYP.

CRISS-CROSS FORM FOR DRAINAGE

← GRAIN DIRECTION →

DRAIN (2 PLCS.)

1/2" X 1 1/2" LONG NPT PIPE THREAD (2 PLCS.)

18 GA. PERFORATED SCREEN (Ø .375 ON .50 CENTERS) STANDARD

NOTES:
 ALL DIMENSIONS ARE INSIDE DIMENSIONS (UNLESS OTHERWISE NOTED)

PART # 0206-30-2

PROPRIETARY AND CONFIDENTIAL
 THE INFORMATION CONTAINED IN THIS DRAWING IS THE SOLE PROPERTY OF ACU PRECISION SHEET METAL. ANY REPRODUCTION IN PART OR AS A WHOLE WITHOUT THE WRITTEN PERMISSION OF ACU PRECISION SHEET METAL IS PROHIBITED.
 AMERICAN COFFEE URN MANUFACTURING CO., INC

| | NAME | DATE |
|----------|----------------------------|-------|
| DRAWN | L. WILLIAMS | 05/17 |
| MATERIAL | 18 GA. 304 STAINLESS STEEL | |
| FINISH | #4 BRUSHED | |

| TITLE: |
|---|
| FM-DD FLUSH MOUNT W/DBL. DRAIN 6" X 30" |
| AMERICAN COFFEE URN |